

# Triathlon Series Gas Fryers

## Installation & Operation Manual



**Model TC25**  
(Parts Section Included)



# DEAN



Dean, a member of the Commercial Food Equipment Service Association, recommends using CFESA Certified Technicians.

**24-Hour Service Hotline 1-800-551-8633**

**Price: \$6.00**

**819-5683  
MARCH 2002**

Please read all sections of this manual and retain for future reference.

This product has been certified as commercial cooking equipment and **MUST** be installed by professional personnel as specified. Installation, maintenance and repairs should be performed by your DEAN FACTORY AUTHORIZED SERVICE CENTER.

 **CAUTION**

Do not store or use gasoline or other flammable vapors and liquids in the vicinity of this or any other cooking appliance.

 **CAUTION**

Instructions explaining procedures to be followed **MUST** be posted in a prominent location in the event the operator detects a gas leak. This information can be obtained from the local gas company or gas supplier.

 **WARNING**

Improper installation, adjustment, alteration, service or maintenance can cause property damage, injury or death. Read the installation, operating and maintenance instructions thoroughly before installing or servicing this equipment.

 **WARNING**

Safe and satisfactory operation of your equipment depends on proper installation. Installation **MUST** conform with local codes, or in absence of local codes, with the National Fuel Gas Code, ANSI Z223.1; The Natural Gas Installation Code, CAN/CGA-B149.1; The Propane Installation Code, CAN/CGA-B149.2; or The latest edition of the National Electric Code, N.F.P.A. 70.

 **DANGER**

The front ledge of the fryer is not a step. Do not stand on the fryer. Serious injury can result from slips or contact with the hot oil.

 **WARNING**

Drawings and photos used in this manual are intended to illustrate operational, cleaning and technical procedures and may not conform to on-site management operational procedures.

 **WARNING**

No structural material on the fryer should be altered or removed to accommodate placement of the fryer under a hood. Questions? Call the Frymaster/Dean Service Hotline at 1-800-551-8633.

**NOTICE**

The Commonwealth of Massachusetts requires any and all gas products to be installed by a licensed plumber or pipe fitter.



**Triathlon Series Gas Fryers  
Installation & Operation Manual**

**TABLE OF CONTENTS**

	<b>Page #</b>
<b>1. INTRODUCTION</b> .....	<b>1-1</b>
1.1 After Purchase .....	1-1
1.2 Ordering Parts .....	1-1
1.3 Service Information .....	1-1
1.4 Safety Information .....	1-2
<b>2. IMPORTANT INFORMATION</b> .....	<b>2-1</b>
2.1 Product Description .....	2-1
2.2 Principles of Operation .....	2-1
2.3 Rating Plate .....	2-1
2.4 Pre-Installation .....	2-1
2.5 Air Supply and Ventilation .....	2-3
2.6 Equipment Installed at High Altitudes .....	2-3
2.7 Receiving and Unpacking Equipment .....	2-4
<b>3. INSTALLATION</b> .....	<b>3-1</b>
3.1 Installing the Fryer .....	3-1
3.2 Leveling the Fryer .....	3-1
3.3 Gas Connections .....	3-2
<b>4. FRYER OPERATIONS</b> .....	<b>4-1</b>
4.1 Initial Start-up .....	4-1
4.2 Boil-Out Procedure .....	4-3
4.3 Final Preparation .....	4-5
4.4 Extending Oil/Shortening Life .....	4-5
4.5 Opening: Beginning the Workday .....	4-6
4.6 Filtering Basics .....	4-6
4.7 Closing: End of Day .....	4-7
4.8 Fryer Shutdown .....	4-7



**Triathlon Series Gas Fryers  
Installation & Operation Manual**

**TABLE OF CONTENTS (cont.)**

	<b>Page #</b>
<b>5. PREVENTATIVE MAINTENANCE</b> .....	<b>5-1</b>
<b>5.1 General</b> .....	<b>5-1</b>
<b>6. WIRING DIAGRAMS</b> .....	<b>6-1</b>
<b>6.1 Robert Shaw Gas-Valve Wiring</b> .....	<b>6-1</b>
<b>7. PARTS LIST</b> .....	<b>7-1</b>
<b>7.1 Accessories</b> .....	<b>7-1</b>
<b>7.2 Cabinetry and Related Components</b> .....	<b>7-2</b>
<b>7.3 Frypots, Flues and Drain Valves</b> .....	<b>7-4</b>
<b>7.4 Gas Valve and Burner Components</b> .....	<b>7-5</b>
<b>7.5 Thermostat, High-Limit, Pilot and Related Components</b> .....	<b>7-6</b>

# TRIATHLON SERIES GAS FRYERS

## CHAPTER 1: INTRODUCTION

---

### 1.1 After Purchase

In order to improve service, have the following chart filled in by the Frymaster/Dean Authorized Service Technician who installs this equipment.

Authorized Service  
Technician/FASC  
Address

---

---

Telephone/Fax  
Model Number  
Serial Number  
Gas Type

---

---

---

---

### 1.2 Ordering Parts

Customers may order parts directly from their local factory authorized service center. For this address and phone number, contact your factory authorized service center or call the Frymaster/Dean Service Hotline phone number, 1-800-551-8633.

To speed up your order, provide the model number, serial number, gas type, part needed, item part number (if known), and quantity needed.

Model Number

---

Type

---

Serial Number

---

Optional Equipment

---

Item Part Number

---

Quantity Needed

---

### 1.3 Service Information

Call the Dean Service Hotline, 1-800-551-8633, for the location of your nearest factory authorized service center. To assist you more efficiently, always provide the service technician with the model number, gas type, serial number, and the nature of the problem.

Model Number

---

Type

---

Serial Number

---

Optional Equipment

---

Nature of Problem

---

---

# TRIATHLON SERIES GAS FRYERS

## CHAPTER 1: INTRODUCTION

---

### 1.4 Safety Information

Before attempting to operate your unit, read the instructions in this manual thoroughly.

Throughout this manual, you will find notations enclosed in double-bordered boxes similar to the ones below.

**CAUTION** boxes contain information about actions or conditions that *may cause or result in a malfunction of your system*.

 **CAUTION**  
Example of a CAUTION box.

**WARNING** boxes contain information about actions or conditions that *may cause or result in damage to your system*, and which may cause your system to malfunction.

 **WARNING**  
Example of a WARNING box.

**DANGER** boxes contain information about actions or conditions that *may cause or result in injury to personnel*, and which may cause damage to your system and/or cause your system to malfunction.

 **DANGER**  
Hot cooking oil causes severe burns. Never attempt to move a fryer containing hot cooking oil or to transfer hot cooking oil from one container to another.

# TRIATHLON SERIES GAS FRYERS

## CHAPTER 2: IMPORTANT INFORMATION

---

### 2.1 Product Description

Dean Triathlon Series gas fryers are energy-efficient, tube-style, gas-fired tabletop units, design-certified by the International Approval Services (AGA/CGA), National Sanitation Foundation (NSF), and manufactured to their basic performance and application specifications.

All units are shipped completely assembled with accessories packed inside the fryer vessel. All units are adjusted, tested and inspected at the factory before shipment.

**NOTE:** The on-site supervisor is responsible for ensuring that operators are made aware of inherent dangers of operating a deep fat fryer, particularly aspects of oil filtration, draining, and cleaning of the fryer.

### 2.2 Principles of Operation

The incoming gas flows through orifices and is mixed with air in the burners to create the correct ratio for proper combustion. The mixture is ignited at the front end of each heat tube by the pilot light. A flame spreader slows the flame as it goes through the burner tube. This slower and more turbulent flame gives much better heat transfer to the walls of the tubes, thereby heating the oil better.

### 2.3 Rating Plate

The rating plate is found on the right-side panel of the fryer. Information provided includes the model and serial number of the fryer, BTU/hr input of the burners, outlet gas pressure in inches W.C. (mbars) and whether the unit has natural or propane gas orifices.



**Fryers **MUST** be connected **ONLY** to the gas type identified on the attached rating plate.**

### 2.4 Pre-Installation

A. **General:** Only a licensed gas fitter should install any gas-fired equipment.

1. A manual gas shut-off valve must be installed in the gas supply line ahead of the fryers for safety and ease of future service.

**TRIATHLON SERIES GAS FRYERS  
CHAPTER 2: IMPORTANT INFORMATION**

---

## 2.4 Pre-Installation (cont.)

- B. **Clearances:** The fryer area must be kept free and clear of all combustibles. This unit is design-certified for the following installations:

Commercial installation only (not for household use).

Installation on a non-combustible platform when equipped with factory-supplied 4-inch (10.2 cm) adjustable legs.

Non-combustible construction with no minimum clearance of the sides and rear, and combustible construction with a minimum clearance of 6-inches (15-cm) side and 6-inches (15-cm) rear when equipped with factory-supplied 4-inch (10.2-cm) adjustable legs.



**Local building codes usually prohibit a fryer with its open tank of hot oil from being installed beside an open flame of any type, whether a broiler or the open burner of a range.**

C. **Installation Standards:**

<p>1. <u>U.S. installations must meet:</u></p> <p>American National Standard Institute ANSI Z83.11 American Gas Association 8501 E. Pleasant Valley Road Cleveland, OH 44131</p> <p>National Electrical Code ANSI/NFPA #70 American National Standard Institute 1430 Broadway New York, NY 10018</p> <p>NFPA Standards #96 and #211 National Fire Protection Association 470 Atlantic Avenue Boston, MA 02110</p>	<p>2. <u>Canadian installations must meet:</u></p> <p>CAN 1-B149 Installation Codes Canadian Gas Association 55 Scarsdale Road Don Mills, ONT, M3B 2R3</p> <p>Canadian Electric Code c22.1, part 1 Canadian Standards Association 178 Rexdale Blvd. Rexdale, ONT, M9W 1R3</p>
---	---

3. CE/EXPORT STANDARDS: Fryer installation must conform with local codes, or in the absence of local codes, to the appropriate national or European Community (CE) standards.



**TRIATHLON SERIES GAS FRYERS**  
**CHAPTER 2: IMPORTANT INFORMATION**

---

## **2.5 Air Supply and Ventilation**

Keep the area around the fryer clear to prevent obstruction of combustion and ventilation airflow as well as for service and maintenance.

- A. Do not connect this fryer to an exhaust duct.
- B. Correct installation and adjustment will ensure adequate airflow to the fryer system.
- C. A commercial, heavy-duty fryer must vent its combustion wastes to the outside of the building. A deep-fat fryer must be installed under a powered exhaust hood, or an exhaust fan must be provided in the wall above the unit, as exhaust gas temperatures are approximately 500-900°F (260-482°C). Check air movement during installation. Strong exhaust fans in the exhaust hood or in the overall air conditioning system can produce slight air drafts in the room.
- D. Do not place the fryer's flue outlet directly into the plenum of the hood, as it will affect the gas combustion of the fryer.
- E. Never store items on shelving over or behind the fryer. Exhaust temperatures can exceed 800°F (427°C) and may damage or melt items stored near the fryer.
- F. Adequate distance must be maintained from the flue outlet of the fryer(s) to the lower edge of the filter bank. Per NFPA Standards No. 96, a minimum of 18-inches (45-cm) should be maintained between the flue(s) and the lower edge of the exhaust hood filter.
- G. Filters and drip troughs should be part of any industrial hood, but consult local codes before constructing and installing any hood. The duct system, the exhaust hood and the filter bank must be cleaned on a regular basis and kept free of grease.

## **2.6 Equipment Installed at High Altitudes**

- A. The fryer input rating (BTU/hr) is for elevations up to 2,000 feet (610-m). For elevations above 2,000 feet (610-m), the rating should be reduced four percent for each additional 1,000 feet (305-m) above sea level.
- B. The correct orifices are installed at the factory if operating altitude is known at time of the customer's order.

**TRIATHLON SERIES GAS FRYERS**  
**CHAPTER 2: IMPORTANT INFORMATION**

---

## **2.7 Receiving and Unpacking Equipment**

- A. Check that the container is upright. Use an outward prying motion - *no hammering* - to remove the carton. Unpack the fryer carefully and remove all accessories from the carton. Do not discard or misplace these, as they will be needed.
- B. After unpacking, immediately check the equipment for visible signs of shipping damage. If damage has occurred, contact the carrier and file the appropriate freight claims. Do not contact the factory. Shipping damage responsibility is between the carrier and the dealer.

**If your equipment arrives damaged:**

- 1. File claim for damages immediately, regardless of extent of damage.
- 2. Visible loss or damage: Be sure this is noted on the freight bill or express receipt and is signed by the person making the delivery.
- 3. Concealed loss or damage: If damage is unnoticed until equipment is unpacked, notify freight company or carrier immediately, and file a concealed damage claim. This should be done within 15 days of date of delivery. Be sure to retain container and all packing materials for inspection.

**NOTE: Dean Does Not Assume Responsibility for Damage or Loss Incurred in Transit.**

- C. Remove all plastic skin from sides, front, and doors of the fryer(s). Failure to do this prior to initial fryer operation will make the plastic very difficult to remove later.

# TRIATHLON SERIES GAS FRYERS

## CHAPTER 3: INSTALLATION

---

### 3.1 Installing the Fryer

- A. Initial Installation: Legs are installed at the factory. After unpacking, check the legs to ensure they are properly tightened.
- B. Relocating the fryer: Lift the fryer to remove all weight from each leg before moving. Do not slide the fryer on the legs.
- C. If a leg becomes damaged, contact a service agent for immediate repair/replacement.

### 3.2 Leveling the Fryer

- A. **All Installations**: It is recommended to place the fryer on an even platform.
- B. Place a spirit level across the top of the fryer and level the unit both front-to-back and side-to-side. If the unit is not level, it may not function efficiently, and the oil may not drain properly.
- C. Adjust to the high corner and measure with the spirit level. If floor is uneven, level the unit with the screw adjustments on each leg (see illustration below). **Ensure minimum clearances as discussed in Chapter 2 are maintained during the leveling procedure.**

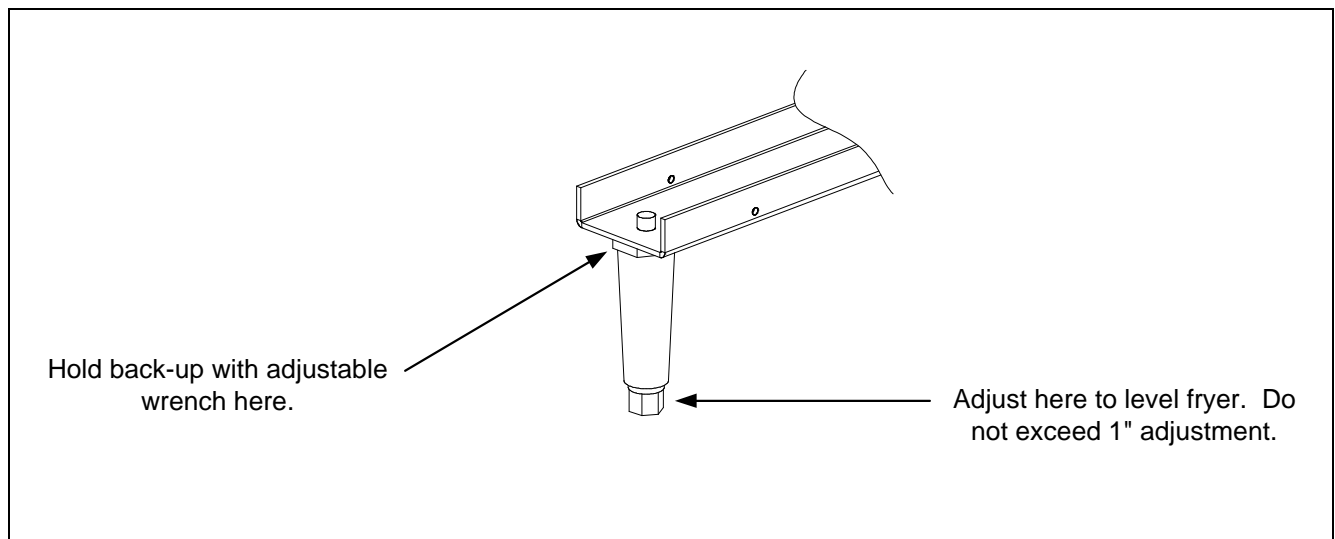

**TRIATHLON SERIES GAS FRYERS**  
**CHAPTER 3: INSTALLATION**

---

### 3.2 Leveling the Fryer (cont.)

- D. **Re-leveling:** If the fryer is moved, re-level the fryer following the above instructions.
- E. The install must be reviewed at the time of installation to ensure it meets the intent of these instructions.

 **CAUTION**

**Fryers must be at room temperature, empty of oil and lifted during movement to avoid damage and possible bodily injury.**

 **DANGER**

**Hot shortening can cause severe burns. Avoid contact. Under all circumstances, oil must be removed from the fryer before attempting to move it to avoid oil spills, and the falls and severe burns that could occur. This fryer may tip and cause personal injury if not secured in a stationary position.**

### 3.3 Gas Connections

- A. The gas supply (service) line must be the same size or greater than the fryer inlet line. This fryer is equipped with a 3/4" (19 mm) male inlet. The gas supply line must be sized to accommodate all the gas-fired equipment that may be connected to that gas supply. Consult your contractor, gas company, supplier, or other knowledgeable authorities.

 **CAUTION**

**All connections must be sealed with a joint compound suitable for the gas being used, and all connections must be tested with a soapy solution before lighting any pilots.**

- B. Rigid Connections: Check any installer-supplied intake pipe(s) visually and clean threading chips, or any other foreign matter before installing into a service line. If the intake pipes are not clear of all foreign matter, the orifices will clog when gas pressure is applied. Seal pipe joints with a sealant resistive to LP gas. When using thread compound on gas piping, use very small amounts and only on male threads. Use a pipe thread compound that is not affected by the chemical action of LP gases. **DO NOT** apply thread compound to the first two pipe threads—doing so will cause clogging of the burner orifices and control valve.

**TRIATHLON SERIES GAS FRYERS  
CHAPTER 3: INSTALLATION**

---

### **3.3 Gas Connections (cont.)**

- C. Manual shut-off valve: This gas service supplier-installed valve must be installed in the gas service line ahead of the fryers in the gas stream and in a position where it can be reached quickly in the event of an emergency.
- D. Regulating Gas Pressure: The fryer and shut-off valve must be disconnected from the gas supply during any pressure testing of the system.
  - 1. External gas regulators are not normally required on this fryer. A safety control valve protects the fryer against pressure fluctuations. If the incoming pressure is in excess of ½" PSI (3.45 kPa/35 mbar), **a step-down regulator will be required.**

 **CAUTION**

**The fryer must be isolated from the gas supply piping system by closing its individual manual shut-off valve during any pressure testing of the gas supply piping system at pressures equal to or less than ½ PSI (3.45 kPa/35 mbar).**

**The fryer and its individual shut-off valve must be disconnected from the gas supply piping system during any pressure testing of the gas supply system at test pressures in excess of ½ PSI (3.45 kPa/35 mbar).**

- E. Manifold Pressure: Your local service technician should check the manifold pressure with a manometer.
  - 1. Check the rating plate for manifold gas pressures. Natural gas units require 3.5" W.C. (8.71 mbar) and propane requires 10" W.C. (25 mbar).
  - 2. When installing a pressure regulator, ensure the arrow forged into the bottom of the regulator body is pointing downstream, towards the fryer. The air vent cap is also part of the regulator and should not be removed.
  - 3. If a vent line from the gas pressure regulator is used, it should be installed in accordance with local codes or in the absence of local codes, with the National Fuel Gas Code, ANSI Z223.1-(latest edition).

 **WARNING**

**Use a diluted soap solution to find potentially dangerous gas leaks when making new connections.**

- F. Regulators can be adjusted in the field, but it is recommended that they not be tampered with unless the part is known to be out of adjustment or serious pressure fluctuations are found to exist and can be solved no other way.

**TRIATHLON SERIES GAS FRYERS**  
**CHAPTER 3: INSTALLATION**

---

### **3.3 Gas Connections (cont.)**

- G. Only qualified service personnel should make adjustments to the regulators.
- H. Orifices: The fryer can be configured to operate on any available gas. The correct safety control valve, appropriate gas orifices, and pilot burner are installed at the factory. While the valve can be adjusted in the field, only qualified service personnel should make any adjustments with the proper test equipment.

 **WARNING**

**If gas odors are detected, the gas supply must be shut off at the main shut-off valve. The local gas company or FASC should be contacted immediately to rectify the problem.**

- I. After connecting the fryer to the gas supply, bleed the gas line of air to ensure that the pilot will ignite quickly.

# TRIATHLON SERIES GAS FRYERS

## CHAPTER 4: FRYER OPERATIONS

---

### 4.1 Initial Start-up

- A. Cleaning: New units are wiped clean with solvents at the factory to remove any visible signs of dirt, oil, grease, etc. remaining from the manufacturing process, then coated lightly with oil. Before any food preparation, wash thoroughly with hot, soapy water to remove any film residue and dust or debris then rinse out and wipe dry. Also wash any accessories shipped with the unit. Close the drain valve (see photo below) completely and remove the crumb screen covering the heating tubes. Ensure the screws holding the thermostat and high-limit control sensing bulbs (see photo below) into the vessel are tight.

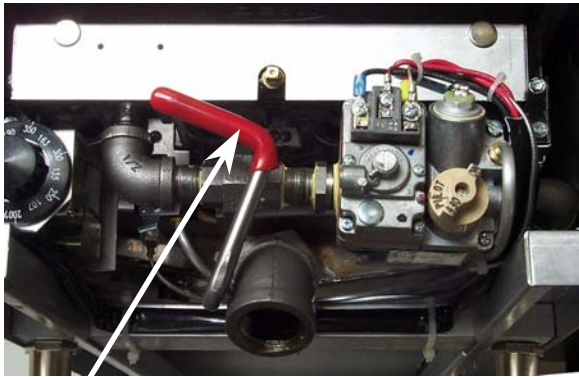

Drain valve handle (red).



Sensing-bulb location in fry vessel.

#### 4.1.1 Pilot Lighting Procedures

Initial Pilot Lighting: All Dean fryers are tested, adjusted and calibrated to sea level conditions before leaving the factory. Adjustments to assure proper operation of pilot may be necessary on installation to meet local conditions, low gas pressure, differences in altitude and variations in gas characteristics. These adjustments correct possible problems caused by rough handling or vibration during shipment, and are to be performed only by qualified service personnel. These adjustments are the responsibility of the customer and/or the dealer and are not covered by the Dean warranty.

The inlet pipe at the lower rear of the fryer brings incoming gas to the pilot safety control valve, then to the pilot and main burners. The pilot is located high in the cabinet, left-center, at the base of the fryer vessel.

Pilot and thermopile location (arrow).

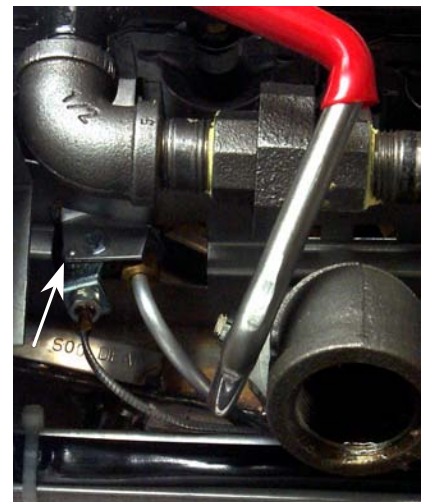

## TRIATHLON SERIES GAS FRYERS CHAPTER 4: FRYER OPERATIONS

### 4.1.1 Pilot Lighting Procedures (cont.)

Light the pilot as follows:

1. Turn off the manual shut-off valve on the incoming service line.
2. Turn the operating thermostat off.

Operating thermostat in "OFF" position.

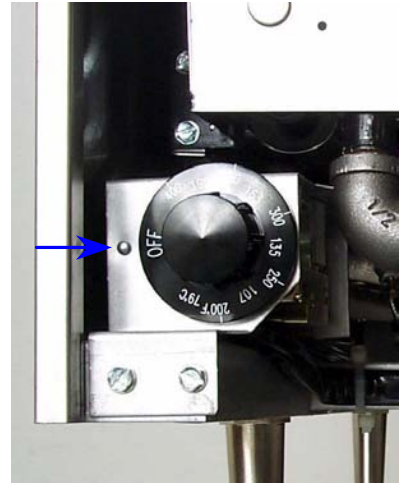

3. Depress the pilot gas cock dial on the combination control valve and turn to "OFF".
4. Wait approximately 5 minutes for accumulated gas to disperse.

**Note: Inspect high-limit thermostat/temperature probe location prior to filling fry vessel with water or oil. Ensure that connecting hardware is intact and properly tightened, and the bulbs are properly attached.**

5. Fill the fry vessel with oil/shortening or water to the bottom OIL LEVEL line scribed on the vessel back.

NOTE: See **Section 4.3.1** for specific instructions when using solid shortening.

Ensure that heating tubes are covered in liquid or shortening prior to engaging burners.

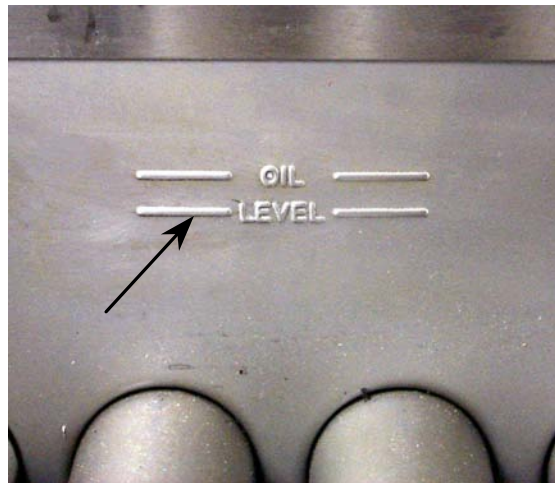

Fill the fry vessel with oil or water to the bottom OIL LEVEL line.



# TRIATHLON SERIES GAS FRYERS

## CHAPTER 4: FRYER OPERATIONS

---

### 4.1.1 Pilot Lighting Procedures (cont.)

6. Open the manual shut-off valve on the incoming service line.
7. Apply lighted match or taper to the pilot burner head.
8. Turn the gas cock dial on the control valve to "Pilot", then depress and hold the dial until the pilot stays lit (approximately 1 minute).

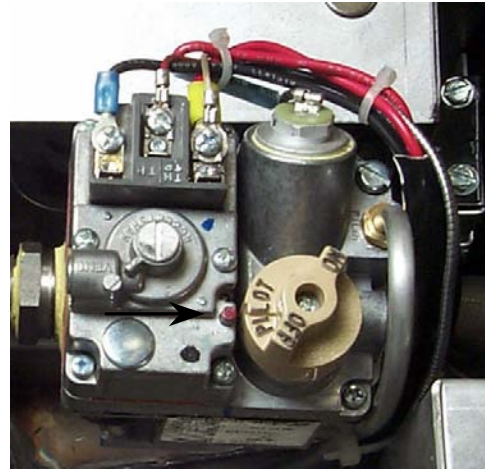

Gas cock dial in the "pilot" position.

9. If the pilot fails to stay lit, depress the dial and re-light the pilot, depressing the dial longer before releasing.
10. When the pilot stays lit, turn the gas cock dial to "ON".
11. Turn the operating thermostat on, and then ensure the main burners ignite from the pilot.

### **WARNING**

**When checking for burner ignition or performance, do not get too close to the burners. Slow ignition can cause possible flashback, increasing the potential for facial and body burns.**

### 4.2 Boil-Out Procedure

- A. Pour cleaning solution into the fry vessel and add water to the bottom OIL LEVEL line scribed in the back of the fry vessel.
- B. Set the operating thermostat dial/temperature controller to 225°F (107°C), just above that of boiling water.
- C. The main burner will ignite.
- D. Reset the temperature controller to 200°F (93°C) when the solution starts to boil.

## TRIATHLON SERIES GAS FRYERS

### CHAPTER 4: FRYER OPERATIONS

---

#### 4.2 Boil-Out Procedure (cont.)

- E. The burners will maintain the boil-out solution at a simmer. Simmer the solution for approximately 45 minutes. Wearing protective gloves, scrub the sides of the fry vessel and the tubes with the L-shaped Teflon brush, being careful not to disturb the temperature sensing probe and the high-limit thermostat. **USE CARE NOT TO SPLASH SOLUTION WITH BRUSH- SOLUTION IS HOT!**
- F. Do not allow the water level to decrease below the bottom **OIL LEVEL** line in fry vessel during boil-out operation.
- G. After boil out is complete, turn the thermostat dial to "OFF" and drain the solution from the fry vessel. Place a metal pan or bucket under the drain port to collect the water from the fry vessel.
- H. Close the drain, add fresh water (without boil-out solution) and wash all surfaces of the fry vessel. Drain again.
- I. Refill the fry vessel with fresh water and vinegar to neutralize any residual boil-out solution. Wash all surfaces of the fry vessel. Drain completely and wipe down all surfaces of the fry vessel to completely eliminate water from the vessel.

 **CAUTION**

**All drops of water MUST be removed from fry vessel before filling with cooking oil. Do not turn fryer on to dry... extensive damage will occur to fry vessel and burner tubes, and ALL applicable warranties will be voided.**

**NOTE:** For a fresh start and prolonged fry vessel life, it is recommended that the boil-out procedure be performed each time the oil/shortening is changed.

 **WARNING**

**Do not go near the area directly over the flue outlet while the fryer is operating.**

**Always wear oil-proof, insulated gloves when working with the fryer filled with hot oil.**

**Always drain hot oil into a metal container. Hot oil can melt plastic buckets and crack glass containers.**

# TRIATHLON SERIES GAS FRYERS

## CHAPTER 4: FRYER OPERATIONS

---

### 4.3 Final Preparation

 **WARNING**

**NEVER set a complete block of solid shortening on top of heating tubes. To do so will damage the heating tubes and fry vessel, and void the warranty.**

#### 4.3.1 Filling Fryer with Cooking Oil/Shortening

- A. When using a liquid shortening (cooking oil), fill the fryer to the bottom OIL LEVEL line scribed into the back of the fryer vessel.
- B. When using a solid shortening, first melt it in a suitable container, or cut it into small pieces and pack it below the heat tubes, between the tubes and on top of the tubes, leaving no air spaces around the tubes. Do not disturb or bend the sensing bulbs.
- C. If the shortening is not melted first, turn the burners "ON" for about 10 seconds, "OFF" for a minute, etc., until the shortening is melted. If you see smoke coming from the shortening while melting this way, shorten the "ON" cycle and lengthen the "OFF" cycle. Smoke indicates potential scorching of the shortening, which will shorten its useful life.
- D. Before starting operation, turn the operating thermostat to the probable working temperature; wait for the temperature to stabilize then check with a high-quality immersion thermometer to ensure that the thermostat is properly calibrated.

### 4.4 Extending Shortening/Oil Life

Although 350°F (177°C) is the recommended temperature for most cooking operations, set the fryer at the lowest possible temperature which produces a high-quality end product. This ensures maximum life of shortening.

When the fryer is not in use, set the thermostat to a lower temperature than that used during cooking. Light loads, too, may be cooked at lower temperatures. A good operator should experiment to determine the optimum temperature and load conditions for the various food items.

## TRIATHLON SERIES GAS FRYERS

### CHAPTER 4: FRYER OPERATIONS

---

#### 4.5 Opening: Beginning the Workday

**At the beginning of each work day, always check the fryer to ensure:**

1. The combination or main gas valve is "OFF".
2. Fry vessel is filled with liquid oil to the bottom OIL LEVEL line scribed into the rear wall of the fry vessel tank.

**To light the fryer:**

1. Open the manual shut-off valve on the incoming service line.
2. Light the pilot. See Section 4.1.1 for pilot lighting procedures.

**After the pilot is lit:**

1. Turn the gas cock dial to "ON".
2. Turn the thermostat to the desired cooking temperature. Watch to ensure the main burner ignites from the pilot.
3. Allow the oil/shortening-filled fry vessel to heat for approximately 30 minutes before cooking. Oil temperature will stabilize at the desired setpoint, ensuring quality cooking.

#### 4.6 Filtering Basics



**When filtering, never leave the filter unit unattended. Oil moving through the lines can knock the flexible return hose out of the fryer, spraying hot oil and causing severe burns.**

**For filtration instructions and troubleshooting, see your operating manual provided with the filter unit.**

**Basic rules of filtering are:**

- Ø The shortening should be filtered at least daily or even more frequently if cooking is heavy. Filtering ensures long shortening life, better tasting food and minimizes flavors being transferred from batch to batch.
- Ø If using solid shortening, always ensure the hose lines are clear before de-activating the filter system. Also, hang flexible hose lines up to drain to prevent solid shortening from solidifying in the lines.

## TRIATHLON SERIES GAS FRYERS

### CHAPTER 4: FRYER OPERATIONS

---

#### 4.7 Closing: End of Day

##### When closing at night:

- Ø Filter the oil in all fryers and drain the flexible hose lines (portable filters).
- Ø Cover oil-filled, open fry vessels.
- Ø Turn the control knob on the gas valve to "OFF".

#### 4.8 Fryer Shutdown

##### When closing down for periods longer than overnight:

- Ø Drain the shortening and clean the vessel thoroughly.
- Ø Discard or filter the shortening, then return filtered shortening to fry vessel. Install fry vessel cover to prevent shortening contamination.
- Ø Non-stainless Fry Vessels Only: If shortening is discarded, lightly coat the inside of non-stainless (mild steel) fry vessels with fresh shortening after cleaning to prevent rusting.
- Ø Turn the control knob on the gas valve to "OFF".
- Ø Turn the manual valve on the incoming gas service line to "OFF".
- Ø Disconnect the portable filter power cord (if used) from the wall socket.

# TRIATHLON SERIES GAS FRYERS

## CHAPTER 5: PREVENTATIVE MAINTENANCE

---

### 5.1 General

Any equipment works better and lasts longer when maintained properly and kept clean. Cooking equipment is no exception. Your Triathlon fryer should be kept clean during the working day, and thoroughly cleaned at the end of each day. Below are recommendations for daily, weekly and periodic preventative maintenance.

#### 5.1.1 Daily

- A. Remove and wash all removable parts.
- B. Clean all exterior surfaces of the cabinet. Do not use cleaners, steel wool, or any other abrasive material on stainless steel.
- C. Filter the cooking oil and replace if necessary. The oil should be filtered more frequently when under heavy use.

#### 5.1.2 Weekly

- A. Completely drain the oil from the fryer into a suitable container for disposal. Do not use a glass or plastic container.
- B. Clean the fry-vessel by following boil-out procedures in Chapter 4-2.

 **CAUTION**

**Never allow water to boil down and expose the heating tubes. Fry vessel damage will result.**

#### 5.1.3 Periodic

The fryer should be inspected and adjusted periodically by qualified service personnel as part of a regular kitchen maintenance program.

**TRIATHLON SERIES GAS FRYERS**  
**CHAPTER 5: PREVENTATIVE MAINTENANCE**

---

**5.1.4 Stainless Steel Care**



**DO NOT let water splash into the tank of hot oil. It will splatter and can cause severe burns.**

All stainless steel fryer cabinet parts should be wiped regularly with hot, soapy water during the day, and with a liquid cleanser designed for stainless steel at the end of each day.

- A. Do not use steel wool, abrasive cloths, cleansers or powders.
- B. Do not use a metal knife, spatula or any other metal tool to scrape stainless steel! Scratches are almost impossible to remove.
- C. If it is necessary to scrape the stainless steel to remove any encrusted materials, soak the area first to soften the deposit, then use a wood or nylon scraper only.

# TRIATHLON SERIES GAS FRYERS

## CHAPTER 6: WIRING DIAGRAMS

### 6.1 Robert Shaw Gas-Valve Wiring

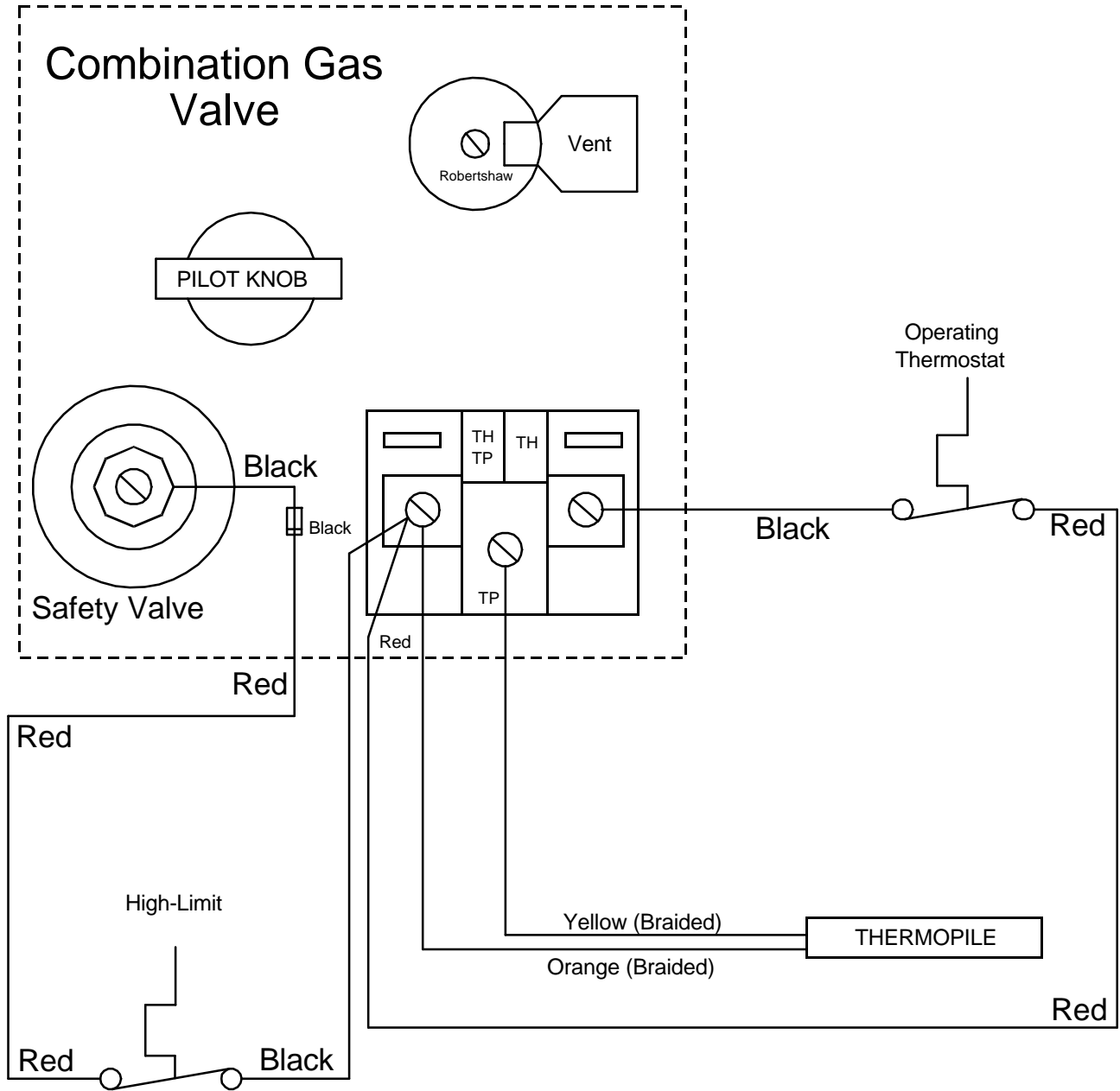



# TRIATHLON SERIES GAS FRYERS

## CHAPTER 7: PARTS LIST

### 7.1 Accessories

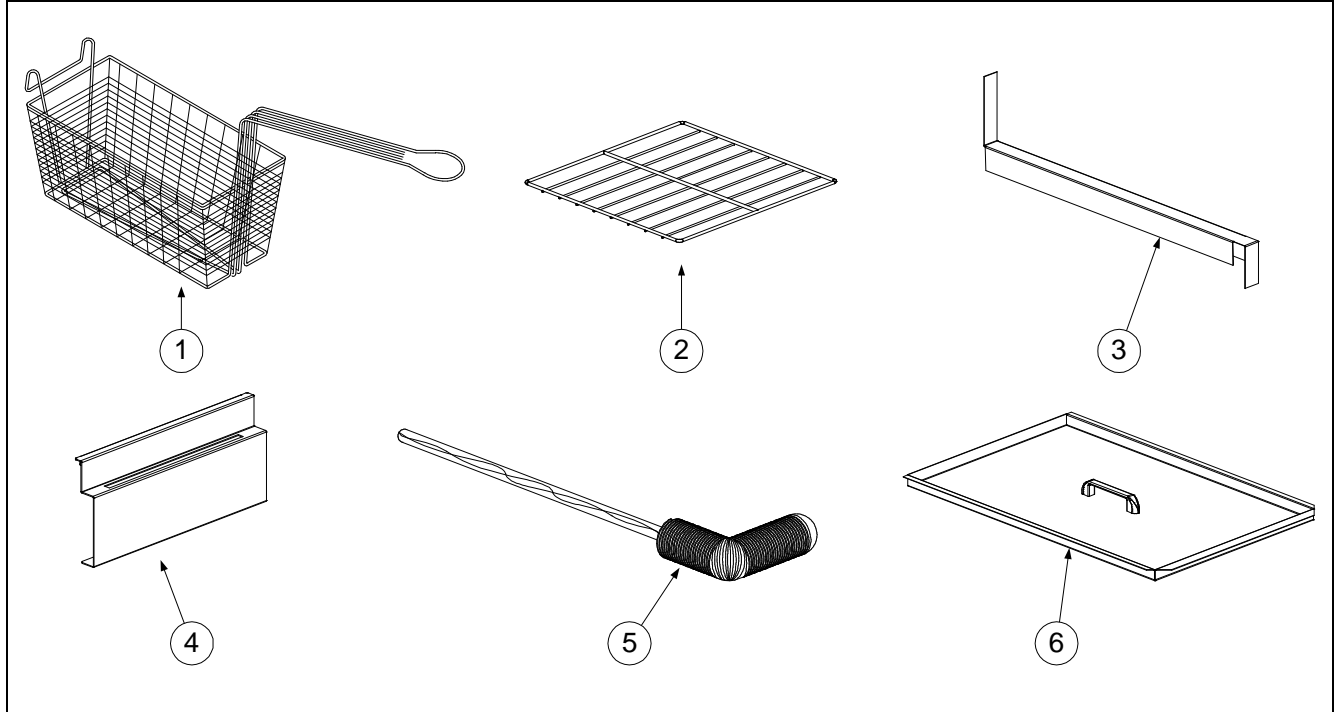

Item	Part Number	Description
1	803-0282	Basket, Fry, 4-1/8 x 5-3/8 x 11"
2	803-0273	Rack, Basket
3	210-1758	Joiner Strip- TC Series
4	210-1220	Basket Hanger
5	803-0278	Brush, Frypot- L-Shaped Teflon
6	106-1915SP	Cover, Frypot
*	803-0197	Fryer's Friend (Clean-out Rod)
* Not Illustrated		

TRIATHLON SERIES GAS FRYERS  
CHAPTER 7: PARTS LIST

7.2 Cabinetry and Related Components

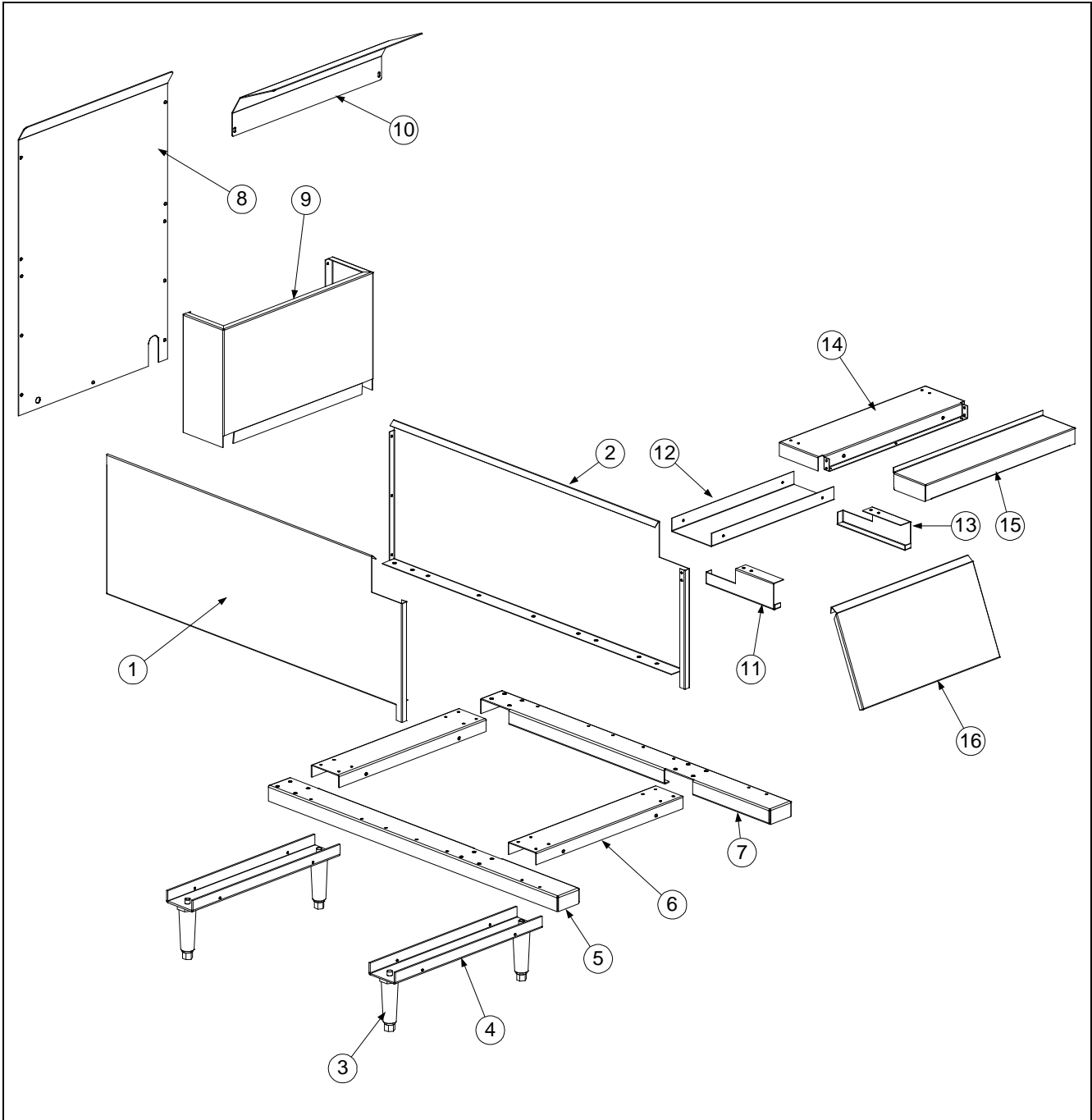

**TRIATHLON SERIES GAS FRYERS  
CHAPTER 7: PARTS LIST**

---

**7.2 Cabinetry and Related Components (cont.)**

<b>Item</b>	<b>Part Number</b>	<b>Description</b>
1	211-2943	Panel, Side- Left
2	212-2943	Panel, Side- Right
3	810-2106	Leg, Adjustable
4	200-3035SP	Channel, Lower- Front & Back
5	201-2944	Channel, Top (Leg)- Right
6	200-2945	Channel, Upper- Front & Back
7	202-2944	Channel, Top (Leg)- Left
8	200-3028	Back, Cabinet
*	809-0816	Screw, 10-16 x ½" Hex Head
*	809-0888	Clip, Tinnerman
9	823-3655	Flue Cap
10	200-3122	Deflector, Heat ( <b>Japan</b> )
11	202-1728	Channel, Sliding Door- Left
12	200-2940	Cover, Insulation
13	201-1728	Channel, Sliding Door- Right
14	200-2937	Brace, Cross-Top
15	824-0968	Topcap, TC-25
16	210-1218	Door, Sliding

**TRIATHLON SERIES GAS FRYERS**  
**CHAPTER 7: PARTS LIST**

**7.3 Frypots, Flues and Drain Valves**

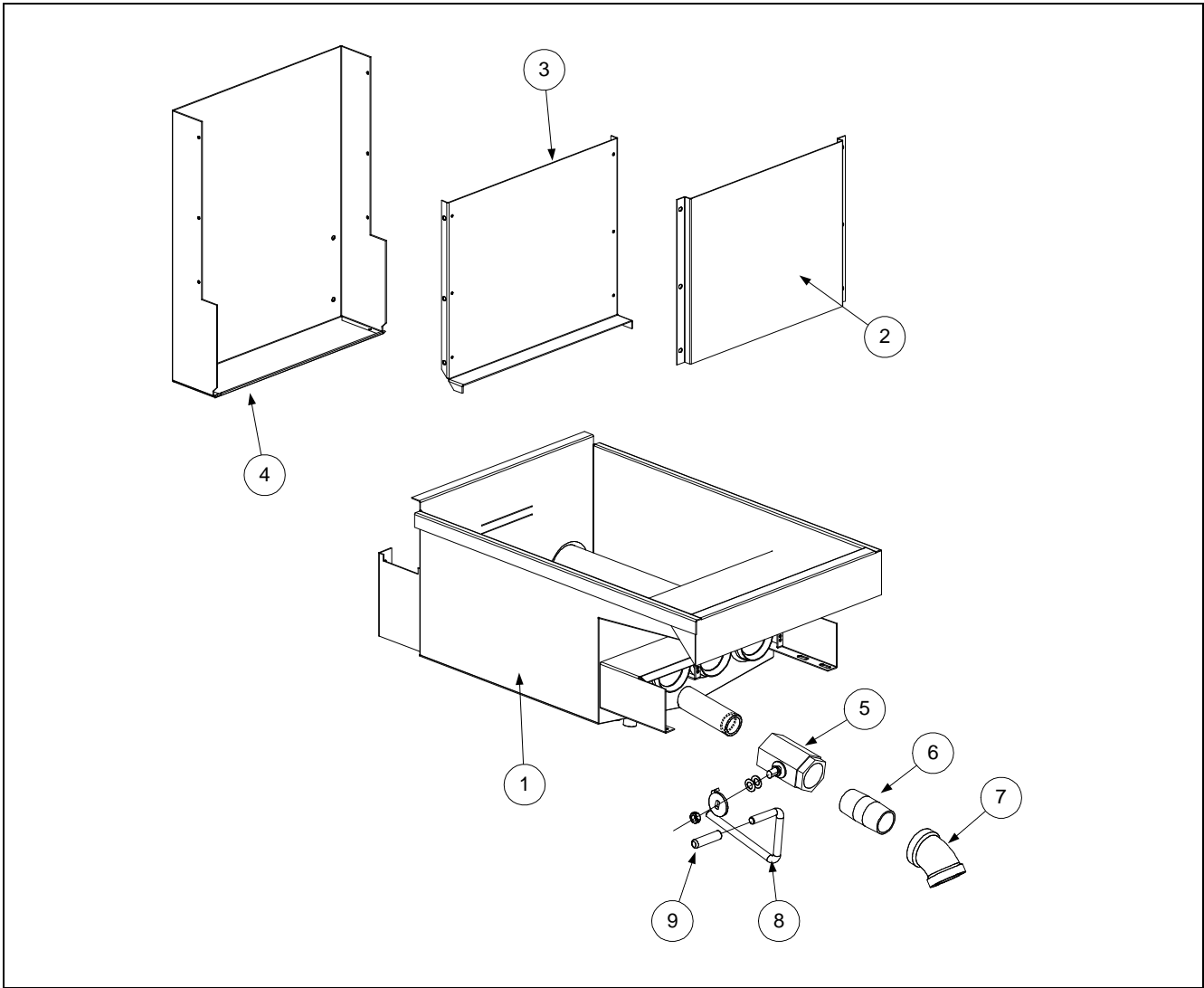

Item	Part Number	Description
1	823-3290SP	Frypot Assembly, TC-25
2	200-1734	Shield, Heat- Flue
3	200-1725	Flue, Front
4	200-1724	Flue, Back
5	810-2128	Valve, Drain- 1" (Nut & Washers Included)
6	813-0710	Nipple, 1 x 2-½" NPT BM
7	813-0709	Elbow- 1"- 45°
8	823-3293	Handle, Drain Valve
9	816-0547	Cap, Vinyl- Drain Valve Handle (Red)

**TRIATHLON SERIES GAS FRYERS  
CHAPTER 7: PARTS LIST**

**7.4 Gas Valve & Burner Components**

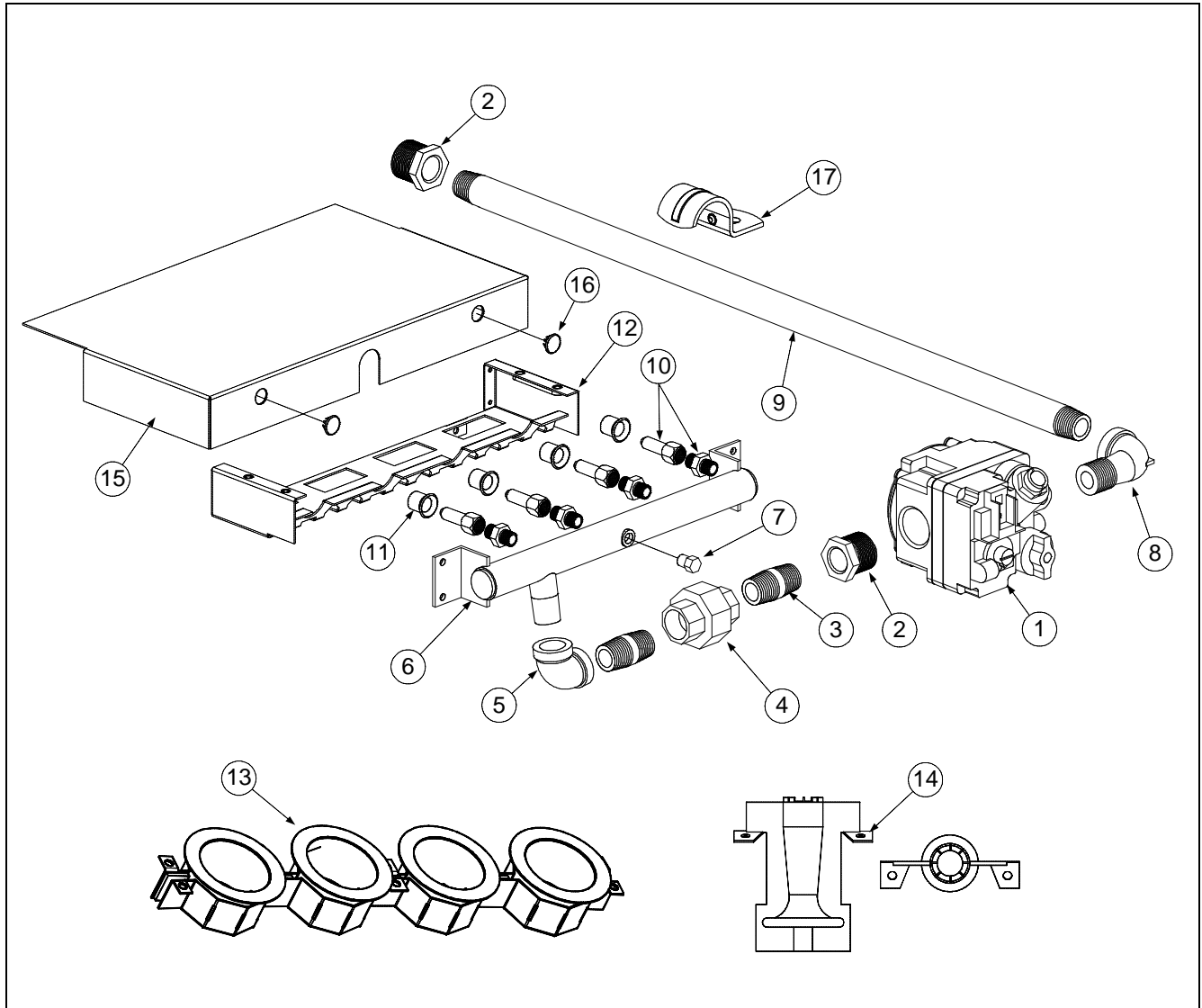

Item	Part Number	Description
1	807-3645	Gas Valve- Natural- MV
*	1909	Gas Valve- Propane- MV
2	813-0031	Bushing, 3/4 x 1/2" NPT BM
3	813-0622	Nipple, 1/2 x 1-1/2" NPT BM
4	813-0173	Union. 1/2" NPT
5	813-0062	Elbow, 1/2" 90°
6	810-2075	Manifold, Gas
*Not Illustrated		

**TRIATHLON SERIES GAS FRYERS  
CHAPTER 7: PARTS LIST**

**7.4 Gas Valve & Burner Components (cont.)**

Item	Part Number	Description
7	813-0154	Plug, 1/8" NPT Hex Head
8	813-0165	Elbow, Street 90°
9	813-0694	Nipple, ½ x 25" NPT BM
*	200-1745	Shield, Heat- Pipe Inlet
10	810-2219	Orifice Assembly, Natural (#47)
*	1826-5	Orifice Assembly, Propane (#56)
11	810-2225	Collar, Aligning- Orifice
12	823-3292	Bracket, Burner
13	810-2336	Spreader, Flame
14	810-2286	Burner, Center
*	810-2285	Burner, Right
*	810-2279	Burner, Left
15	823-3602	Shield, Front
16	810-0179	Plug, Button- ½" Diameter Hole (Front Shield)
17	810-2043	Clamp, Pipe- ½"
*Not Illustrated		

**7.5 Thermostat, High-Limit, Pilot and Related Components**

Item	Part Number	Description
*	807-3515	Thermostat, Sunne
*	816-0546	Knob, Thermostat
*	810-2047	Spring, Thermostat Probe Bulb Mounting
*	807-3516	High-Limit, 435°F
*	810-2046	Spring, High-Limit Probe Bulb Mounting
*	200-1219	Bracket, Thermostat and High-Limit
*	810-2158	Pilot Assembly, Natural
*	200-1732	Bracket, Pilot Assembly
*	810-2033	Thermopile
*Not Illustrated		



Dean, 8700 Line Avenue, PO Box 51000, Shreveport, Louisiana 71135-1000  
Shipping Address: 8700 Line Avenue, Shreveport, Louisiana 71106

TEL 1-318-865-1711 FAX (Parts) 1-318-219-7140 FAX (Tech Support) 1-318-219-7135

PRINTED IN THE UNITED STATES

SERVICE HOTLINE  
1-800-551-8633

Price: \$6.00  
819-5683  
MARCH 2002