

# 24G Series Flatbottom Gas Fryers Installation & Operation Manual



**Models 1824G & 2424G**  
(Parts List Included)



Dean, a member of the Commercial Food Equipment Service Association, recommends using CFESA Certified Technicians.

**24-Hour Service Hotline 1-800-551-8633**

**Price: \$6.00**

**819-5697  
12-01**

**⚠ DANGER**

**IMPROPER INSTALLATION, ADJUSTMENT, ALTERATION, SERVICE, OR MAINTENANCE CAN CAUSE PROPERTY DAMAGE, INJURY, OR DEATH. READ THE INSTALLATION, OPERATING, AND SERVICE INSTRUCTIONS THOROUGHLY BEFORE INSTALLING OR SERVICING THIS EQUIPMENT.**

**⚠ DANGER**

**FOR YOUR SAFETY, DO NOT STORE OR USE GASOLINE OR OTHER FLAMMABLE LIQUIDS OR VAPORS IN THE VICINITY OF THIS OR ANY OTHER APPLIANCE.**

**⚠ DANGER**

**POST IN A PROMINENT LOCATION THE INSTRUCTIONS TO BE FOLLOWED IN THE EVENT THE USER SMELLS GAS. THIS INFORMATION SHALL BE OBTAINED BY CONSULTING THE LOCAL GAS SUPPLIER.**

**THIS EQUIPMENT IS TO BE INSTALLED IN COMPLIANCE WITH THE BASIC PLUMBING CODE OF THE BUILDING OFFICIALS AND CODE ADMINISTRATORS INTERNATIONAL, INC. (BOCA) AND THE FOOD SERVICE SANITATION MANUAL OF THE FOOD AND DRUG ADMINISTRATION.**

**⚠ CAUTION**

**THE CRUMB TRAY IN FRYERS EQUIPPED WITH A FILTER SYSTEM MUST BE EMPTIED INTO A FIREPROOF CONTAINER AT THE END OF FRYING OPERATIONS EACH DAY. SOME FOOD PARTICLES CAN SPONTANEOUSLY COMBUST IF LEFT SOAKING IN CERTAIN SHORTENING MATERIAL.**

**⚠ DANGER**

**THIS PRODUCT CONTAINS CHEMICALS KNOWN TO THE STATE OF CALIFORNIA TO CAUSE CANCER AND/OR BIRTH DEFECTS OR OTHER REPRODUCTIVE HARM. Operation, installation, and servicing of this product could expose you to airborne particles of glasswool or ceramic fibers, crystalline silica, and/or carbon monoxide. Inhalation of airborne particles of glasswool or ceramic fibers is known to the State of California to cause cancer. Inhalation of carbon monoxide is known to the State of California to cause birth defects or other reproductive harm.**

**DEAN FRYERS EQUIPPED WITH LEGS ARE FOR PERMANENT INSTALLATION. FOR MOVEABLE OR PORTABLE INSTALLATION, DEAN OPTIONAL EQUIPMENT CASTERS MUST BE USED.**

**QUESTIONS??? CALL 1-800-551-8633.**

**⚠ WARNING**

**THE FRONT LEDGE OF THE FRYER IS NOT A STEP. DO NOT STAND ON THE FRYER. SERIOUS INJURY CAN RESULT FROM SLIPS OR CONTACT WITH THE HOT OIL.**

**NOTICE**

**The Commonwealth of Massachusetts requires any and all gas products to be installed by a licensed plumber or pipe fitter.**



# 24G Series Flatbottom Gas Fryers

Installation, Operation & Maintenance Manual



## TABLE OF CONTENTS

<i>1. DESCRIPTION AND SPECIFICATIONS</i> .....	<i>1</i>
<i>2. PRE-INSTALLATION</i> .....	<i>2</i>
<i>3. RECEIVING AND INSTALLING THE FRYER</i> .....	<i>3</i>
<i>4. INITIAL START-UP</i> .....	<i>5</i>
<i>5. DAILY OPERATION</i> .....	<i>8</i>
<i>6. CLEANING &amp; MAINTENANCE</i> .....	<i>9</i>
<i>7. TROUBLESHOOTING</i> .....	<i>10</i>
<i>8. RECOMMENDED SPARE PARTS/PARTS LIST</i> .....	<i>12</i>
<i>9. FACTORY SERVICE &amp; PARTS ORDERING</i> .....	<i>12</i>
<i>10. SPECIFICATIONS</i> .....	<i>17</i>
<i>11. WIRING DIAGRAMS</i> .....	<i>18</i>

**IMPORTANT**  
**Safe and satisfactory operation of your equipment depends to a great extent on its proper installation. Installation must conform to local codes, or in the absence of local codes, with the National Electrical Code, NFPA 70-1984 (or latest editions).**

**1. DESCRIPTION AND SPECIFICATIONS**

"24G" Series Flatbottom Fryers are energy-efficient, gas fired units, design-certified by the American Gas Association and the National Sanitation Foundation, and manufactured to the basic performance and application specifications listed below. All units are shipped completely assembled, with accessories packed inside the fryer tank. All units are adjusted, tested, and inspected at the factory prior to crating for shipment.

Base units described below are designed for use in a commercial food preparation environment after installation as outlined in this manual.

MODEL	1824G	2424G
FRYING VESSEL Frying Area: Oil Capacity	18 X 24" 45-70 lbs.	24 x 24" 65-90 lbs.
ENERGY REQUIREMENTS: Gas (Nat or Pro.) Electrical	120,000 BTU/Hr 120V/60-1Ø	
APPROXIMATE SHIPPING WEIGHT (lbs)	285	300

**1.1 VESSEL CONSTRUCTION**

The fry vessel is constructed of welded steel with heat transfer ducting on the vessel bottom for efficient heating of oil without scorching.

**1.2 BODY CONSTRUCTION**

Base units come with painted cabinetry or optional stainless steel. Base units come with 6" adjustable legs or optional 5" casters. Multiple units come with casters.

**1.3 OPERATING CONTROLS:**

"24G" Series Flatbottom Fryers come with an operating thermostat for reliable temperature control. Fryers can also be ordered with Thermatron temperature controller (optional) and/or boil-out feature (optional-only available with Thermatron controller).

**1.3.1 Principle of Operation**

A draft inducer is used to draw air over the burners for combustion. Air movement directs the combustion products back and forth across the vessel bottom by means of a set of baffles, transferring the heat evenly across the vessel bottom. Cold air is prevented from entering the combustion chamber and cooling the oil during the coasting cycle.

**1.4 AUTOMATIC SAFETY FEATURES:**

- A. High oil temperature detection to shut off power to the main burners through the solenoid-actuated gas valve.
- B. Combustion gas valve includes built-in pressure regulator and pilot safety.
- C. Sail switch built into outlet duct shuts off power to the burners in the event of blower failure.
- D. Optional safety switch built into the drain valve prohibits burner ignition if the valve is not completely closed.

## 1.5 RATING PLATE

The rating plate is on the inside right hand corner of the fryer door. Information on this plate includes the model and serial numbers. When communicating with the factory about a unit or requesting special parts or information, this data is essential for proper identification. Other information on this plate is the BTU/hr output of the burners, outlet gas pressure in inches W.C., and configuration: natural or propane gas.

**"24G" SERIES GAS FRYERS MUST BE CONNECTED ONLY TO THE TYPE OF GAS IDENTIFIED ON THIS RATING PLATE.**

## 2. PRE-INSTALLATION

### 2.1 GENERAL

- A. Installation of gas-fired equipment should be performed by licensed personnel.
- B. A manual gas shut-off valve must be installed in the gas supply line between the appliance(s) and the gas supply for safety and for ease of future service.

### 2.2 CLEARANCES

The appliance area must be kept free and clear of all combustibles. This unit is design-certified for the following installations:

- A. For installations having non-combustible walls;
- B. For installation on a combustible floor when equipped with the factory - supplied six inch legs or casters; and
- C. For installation without legs (on a non-combustible curb or platform).

## 2.3 STANDARDS

Installation must be planned in accordance with all applicable state and local codes, taking into account the following standards:

- A. The fryer and it's individual shut-off valve must be disconnected from the gas supply piping system during any pressure testing of that system at pressures in excess of 1/2 PSI.
- B. The fryer must be isolated from the gas supply piping system by closing it's individual manual shut-off valve during any pressure testing of the gas supply piping system at pressures equal to or less than 1/2 PSI.
- C. National Electrical Code ANSI/NFPA #70-1984:  
American National Standards Institute  
1430 Broadway  
New York, NY 10018
- D. National Fuel Gas Code  
ANSI Z-223.1-1984  
American Gas Association  
1515 Wilson Blvd.  
Arlington, VA 22209
- E. NFPA Standards #96 and #211  
National Fire Protection Association  
470 Atlantic Avenue  
Boston, MA 02110

### **NOTE**

**Local Building codes will usually not permit a deep fat fryer with its open tank of hot oil to be installed beside an open flame of any type, whether a broiler or the open burner of a range. Check local codes before beginning installation.**

## 2.4 AIR SUPPLY & VENTILATION

The area around the appliance must be kept clear to avoid obstruction to the flow of combustion and ventilation air as well as for ease of maintenance and service. Under no conditions is the interior of the fryer's cabinet to be used for storage.

- A. Means must be provided for any commercial, heavy-duty cooking appliance to exhaust combustion wastes to the outside of the building. It is essential that a deep fat fryer be set under a powered exhaust hood or that an exhaust fan be provided in the wall above the unit, as exhaust gas temperatures are in the vicinity of 450-500°F.

Strong exhaust fans in this hood or in the overall air conditioning system can produce slight air drafts in the room, which can interfere with pilot or burner performance. Air movement should be checked during installation. If pilot or burner problems persist, make-up air openings or baffles may have to be provided in the room.

- B. Do not place the flue outlet of the fryer directly into the plenum of the hood, as it will affect the gas combustion of the fryer.
- C. Exhaust temperatures, in addition to the open tank of hot oil, make the storage of anything on shelving over or behind the fryer unsafe.
- D. Filters and drip troughs should be part of any industrial hood, but consult local codes before hood construction and installation.

## 3. RECEIVING & INSTALLING THE FRYER

### 3.1 UNPACKING

Check that the container is upright. Use outward prying - **no hammering** - to remove the carton. Check the fryer(s) for visible damage; if such damage has occurred, do not refuse shipment. Contact the carrier and file the appropriate freight claims. Do not contact the factory, as the responsibility for shipping damage is between the carrier and end user.

Remove, unwrap, wash, and temporarily set aside any accessories shipped with the fryer. These may include:

- Basket hanger with baskets
- Wire crumb screen
- Clean-out rod
- Drain pipe extension
- Teflon cleaning brush

### 3.2 LEGS

Legs (or optional casters) should be installed near where the appliance is to be used, as neither is secure for long transit. After unpacking, raise the unit about a foot to permit the legs to be screwed into their couplings, and lower it gently to keep any undue strain from the legs and internal mounting hardware. It is strongly recommended that a pallet or lift jack be used rather than tilting.

### 3.3 POSITIONING

Do not push against any of the edges of the unit in an attempt to adjust its position. Lift it slightly and place it where it is to be installed. Although all metal parts are deburred during manufacture, accidents could occur if the fryer (or a line-up) should move suddenly while being pushed into position by hand. Pushing a unit (rather than using a lift jack) also increases the probability of bending the leg spindles or the internal coupling connectors.

### 3.4 LEVELING

- A. A carpenter's spirit level should be placed across the top of the fryer and the unit leveled both front-to-back and side-to-side. If it is not level, the unit may not function efficiently, the oil may not drain properly for filtering, and in a line-up it may not match adjacent units.
- B. If the floor is smooth and level, level the unit with a screw thread of the legs; adjust to the high corner and measure with the spirit level. If the floor is uneven or has a decided slope, level the unit with metal shims. The adjustment required may exceed the thread available in the leg.

### 3.5 GAS CONNECTIONS

The gas supply (service) line must be the same size or greater than the inlet line of the appliance. "24G" Series gas fryers use a 3/4" SPT (Schedule 40) inlet; however, the gas supply lines must be sized to accommodate all the gas-fired equipment that may be connected to that supply. Consult your contractor, gas company or supplier, or other cognizant authorities. Sealant on all pipe joints must be resistive to LP gas.

- A. Manual shut-off valve: This supplier-installed valve must be installed in the gas service line ahead of the appliance in the gas stream and in a position where it can be reached quickly in the event of an emergency.
- B. Pressure regulating: All commercial cooking equipment must have a pressure regulator on the incoming service line for safe and efficient operation, since service pressure may fluctuate with local demand. External regulators are not required on this deep fat fryer, as a safety control valve performs that function, unless the incoming pressure is in excess of 1/2" PSI, in which case a step-down regulator will be required.

- C. "24G" Series fryers can be connected to either natural or propane gas, depending on the customer's ordering instructions. The correct combination gas valve and orifices are installed at the factory for the appropriate gas, and while the valve can be adjusted in the field, any adjustment should be made only by qualified service personnel with the proper test equipment.
- D. Rigid Connections: The fryer can be connected singly or as part of multi-unit battery. Check any installer-supplied intake pipe(s) visually and/or blow them out with compressed air to clear dirt particles, threading chips, or any other foreign matter before installing into a service line. Any particles remaining in the line will clog orifices when gas pressure is applied.

All connections must be sealed with a joint compound suitable for LP gas, and all connections must be tested with a soapy solution before lighting any pilots.

**DO NOT USE AN OPEN FLAME TO CHECK FOR GAS LEAKS. Putting an open flame next to a new connection is not only dangerous, but will often miss small gas leaks that a soapy solution would find.**

- E. Flexible Couplings, Connectors
  - 1. If the unit is to be installed with flexible couplings or quick-disconnect fittings, the installer must use a heavy-duty, AGA design-certified commercial connector of at least 3/4" NPT (with suitable strain relief) in compliance with ANSI Z-21.69-1979).  
**DOMESTIC CONNECTORS ARE NOT SUITABLE!**
  - 2. If battered units are installed on casters, some means must be provided to limit the movement of the unit. DO NOT use connectors or associated piping when installing restraints.

**WARNING**  
**It is strongly recommended that a  
single fryer NOT be installed on  
casters.**

### 3.6 ELECTRICAL CONNECTIONS

The wiring diagram is attached to the inside of the fryer door and is included at the end of this manual. "24G" Series gas fryers require 120 volts AC, and are equipped with a 16-3 SJT grounded flexible power cord for direct connection to a 120 volt power supply

Amperage for each unit depends on the accessories supplied with the unit. See detailed instructions packaged with the unit(s).

**WARNING**  
**(ELECTRICAL GROUND  
INSTRUCTIONS)**  
**This appliance is equipped with a  
three-prong (grounding) plug for  
your protection against shock  
hazard, and should be plugged  
directly into a properly grounded,  
three-prong receptacle. Do not cut,  
remove, or otherwise by-pass the  
grounding prong on this plug.**

## 4. INITIAL START-UP

### 4.1 CLEANING

New units are wiped clean with solvents at the factory to remove any visible signs of dirt, oil, grease, remaining from the manufacturing process, then given a light coat of oil. New units should be washed thoroughly with hot, soapy water to remove the film residues and any installation dust or debris before being used for food preparation, then rinsed out and wiped dry. Remove any protective plastic covering prior to operation. Wash and thoroughly dry any accessories shipped with the unit.

Close the drain valve completely and remove the crumb screen.

Ensure the screws holding the thermostat and limit control sensing bulbs into the vessel are properly connected and tight.

### 4.2 INITIAL PILOT LIGHT

"24G" Series gas fryers are tested, adjusted, and calibrated before leaving the factory. Adjustments to assure proper operation may be necessary on installation to meet local conditions, low gas pressure, differences in altitude, variations in gas characteristics or to correct possible problems caused by rough handling or vibration during shipment. Only qualified service personnel should perform the above adjustments. Gas system adjustments are the responsibility of the customer and/or dealer and are not covered under warranty.

If the unit is equipped with a spark ignition system, see section "Pilot Light" instructions.

Initial pilot light or re-light should be performed as follows:

- A. Turn off the manual shut-off valve on the incoming service line.
- B. Turn the operating thermostat or the "Thermatron" controller "OFF".
- C. Depress the pilot gas cock dial on the safety control valve and turn "OFF".
- D. Wait for any accumulated gas to disperse.
- E. Fill the fryer tank with liquid oil (or at least water during testing) to the bottom OIL LEVEL line scribed into the rear wall of the tank.



**WARNING!**  
**IF THE MAIN BURNERS ARE OPERATED WITH THE VESSEL EMPTY, IRREPAIRABLE DAMAGE WILL OCCUR. IF THE VESSEL IS DAMAGED IN THIS WAY, THE ENTIRE VESSEL ASSEMBLY MUST BE REPLACED.**

- F. Open the manual shut-off valve on the incoming service line.
- G. Apply a lighted match or taper to the pilot burner head.
- H. Turn the gas cock on the safety valve to "Pilot", depress and hold the dial until the pilot stays lighted when the dial is released. This may take a minute or longer.
- I. If the pilot does not stay lit, depress the dial and re-light it, holding the dial in longer before releasing. It may be necessary to re-light the pilot several times until the lines are purged of any trapped air and a constant gas flow is attained.
- J. When the pilot stays lit, turn the gas cock dial to "ON".
- K. Turn the thermostat or "Thermatron" controller to any "ON" setting and ensure the main burners ignite from the pilot.

**WARNING!**  
**When lighting pilots and checking for burner performance, do NOT stand with your face close to the burners.... They may ignite with a "pop" and could flash back and cause facial burns.**

#### 4.3 PILOT LIGHT (Electric Spark Ignition)

**WARNING!**  
**NEVER USE A MATCH OR TAPER TO LIGHT THIS IGNITION SYSTEM!**

- A. Turn electric power "OFF".
- B. Close the main gas valve on the incoming line and wait five minutes for any accumulated gas to disperse.
- C. Turn gas "ON".
- D. Set thermostat to desired temperature. If tank is water-filled, set thermostat at 195°F; if oil-filled, set thermostat at 350°F.
- E. Turn electrical power "ON". If the unit is equipped with a drain reset circuit, ensure the switch is reset before proceeding.
- F. The blower motor will come on, activating the "sail" switch in the flue. Power from the sail switch will pass through the transformer to the spark module. The ignitor will spark and open the gas control valve. Once the burners ignite, the spark will stop. The "Thermatron" controller or operating thermostat now controls the fryer.

If the blower motor should fail, the main gas valve will shut off the gas supply.

If the pilot flame fails, the ignition module will shut down the unit and lock out the system. To restart, turn electric power "OFF", wait about 30 seconds for the system to recycle itself, then turn on the power. Follow steps (A) through (F) above.

#### 4.4 HEATING THE VESSEL

Fill the fryer vessel with hot or cold water to the bottom OIL LEVEL line scribed into the back of the tank.

- A. Set the operating thermostat or "Thermatron" controller dial to 195°F, just below that of boiling water. If the unit is equipped with an optional Boil-Out Switch, press the switch to "ON". The boil out circuit will control the vessel temperature during the boil out procedure.
- B. Turn the power switch on the left side of the control panel "ON". If the unit is equipped with a drain reset circuit, ensure the switch is reset before proceeding. Blower will activate and the main burner will ignite.
- C. Check the main burners and, if necessary, adjust the air shutters at each burner to obtain the best flame characteristics. To adjust, loosen the screw of the air shutter until the burner flame tips turn yellow, then the yellow disappears. Tighten the shutter screw, and repeat for all burners.
- D. When satisfied that the burners and thermostat are operating properly, drain the vessel of water and dry thoroughly. Immediately refill the vessel with shortening as directed below.

burners "ON" for about 5-10 seconds, "OFF" for 1 minute, etc., until the shortening is melted. If the oil starts to smoke during the melt cycle, shorten the "ON" cycle and lengthen the "OFF" cycle. Shortening/oil life and quality is greatly reduced if heated to the point of smoking.

**NOTE: NEVER MELT A SOLID BLOCK OF SHORTENING BY SETTING IT WHOLE IN THE VESSEL. THIS IS UNSAFE, INEFFICIENT, AND CAN DAMAGE THE FRY VESSEL.**

- C. Before starting operation, set the operating thermostat or "Thermatron" controller to the desired temperature, wait for the temperature to stabilize, then check the temperature with a high-quality immersion thermometer.

#### **WARNING!**

**The fryer must never be operated without cooking compound or water in the vessel.**

**Never move a fryer filled with a hot liquid.**

**Always wear oil-proof, insulated gloves when working with hot oil.**

**Always drain hot oil into a metal container...hot oil can melt plastic buckets and crack glass containers.**

#### 4.5 FINAL PREPARATION

- A. When using a liquid shortening (cooking oil), fill the fryer to the bottom OIL LEVEL line scribed into the back of the vessel.
- B. When using solid shortening, either melt it first in an approved container, or cut it into small pieces and pack it into the frying vessel, leaving no air spaces and being careful not to disturb the sensing bulbs. Melt the shortening either with the "melt cycle" control or by turning the

#### **CAUTION**

**Do not bang fry baskets or other utensils on the fryer's joiner strip (if applicable). The strip is present to seal the joint between the fry vessels. Banging fry baskets on the strip to dislodge shortening will distort the strip, adversely affecting its fit. It is designed for a tight fit and should only be removed for cleaning.**

## 5. DAILY OPERATION

### 5.1 OPENING

At opening, always check the following:

- A. Gas valve is "OFF".
- B. Power switch is "OFF" (if so equipped).
- C. To light the fryer, see Section 4.2.

### 5.2 GENERAL USE OF THE FRYER

For optimum results, the following general information is offered:

- A. For consistent product quality, convenience, and long-term savings, use a high-quality liquid frying compound.
- B. If using solid shortening, never attempt to melt a block of shortening by setting it whole in the fryer vessel. This is inefficient, dangerous, and can easily cause the vessel bottom to burn through, warp, or overstress the welded seams.
- C. Temperature of frying compound. Although 350°F is the recommended temperature for most cooking operations, frying should be done at the lowest temperature which will produce a high quality end product, which ensures maximum life of the frying compound.

When the fryer is not in use, the temperature controller should be set lower than that used during cooking. Light loads, too, may be cooked at lower temperatures. It is good practice to experiment to determine the optimum temperature and load conditions for the various food items to be cooked.

- D. Salting. Operators sometimes salt the food over the frying vessel. This practice should be avoided, as salt deteriorates the frying compound quickly and flavors everything being cooked, not just the batch being salted.

### 5.3 FILTERING

The frying compound should be filtered at least daily, as described in the instructions packed with the filter, or even more frequently if cooking is heavy. This assures the longest life possible for the frying compound, gives a better taste to the food being prepared, and minimizes flavors being transferred from batch to batch.

**CAUTION!**  
**When filtering, never leave the filter unattended. The action of the oil moving through the lines could jolt a flexible return hose out of the filter pan, spraying hot oil and causing severe burns.**

When completing a filter cycle on units equipped with the optional built-in filter, always close the return valve(s) at the fryer(s) to avoid siphoning oil out of the fryer into the filter, and open the valve at the filter to promote draining of the return lines into the filter pan.

If using solid shortening, always ensure the return lines are clear before turning off the filter motor, and hang any flexible lines up to drain. Solid shortening will solidify as it cools and clog the lines.

### 5.4 CLOSING

When closing at night, filter the oil in all fryers and drain the filter lines. Cover the open tanks of oil. Turn the power switch on the fryer panel "OFF", and turn the control knob on the gas valve "OFF".

### 5.5 SHUT-DOWN

When shutting down for longer than overnight, drain the frying compound, clean the vessel thoroughly, and either discard the frying compound or return it filtered to the vessel and cover it. Turn the manual valve on the incoming service line or combination gas valve "OFF".

Disconnect any 120-volt power cords from the wall sockets or turn off the circuit breakers.

## 6. CLEANING & MAINTENANCE

### 6.1 GENERAL

All appliances work better and last longer when maintained properly and kept clean. Cooking equipment is no exception. Keep the fryer clean during the working day and thoroughly clean at the end of each day.

### 6.2 DAILY

- A. Remove and wash all removable parts.
- B. Clean all exterior surfaces of the body. Do not use cleansers, steel wool, or any other abrasive material on stainless steel (see section below).
- C. Filter the cooking oil and replace if necessary. The oil should be filtered more often than daily under heavy use. See the instructions packaged with your filter for procedures.

### 6.3 WEEKLY

- A. Completely drain the fryer vessel into either the filter or a steel container. Do not use a plastic bucket or glass container.
- B. Clean the vessel with a good grade of cleaner or hot water and a strong detergent.
- C. Close the drain valve and refill with either the cleaning solution or water and detergent.
- D. Bring to a rolling boil, turn the heat down, and let the mixture stand until deposits and/or carbon spots can be rubbed off with the Teflon brush.
- E. Scrub the tank walls, bottom, and heating elements, then drain the vessel and rinse in clean, clear water.
- F. Refill with clean, clear water and boil again.

G. Drain, rinse, and dry thoroughly.

H. Refill with cooking oil or frying compound as directed in the above section.

### 6.4 PERIODIC

Have the fryer checked and adjusted periodically by qualified service personnel as part of a regular kitchen maintenance program.

### 6.5 STAINLESS STEEL

All stainless steel body parts should be wiped regularly with hot, soapy water during the day and with a liquid cleaner approved for stainless steel at the end of each day.

#### **CAUTION!**

**Do not let water splash into the tank of hot oil...it will splatter and can cause severe burns.**

Do not use steel wool, abrasive cloths, cleansers or powders on stainless steel! If it is necessary to remove encrusted materials, soak the area with hot soapy water to loosen the material, then use a wood or nylon scraper. Do not use a metal knife, spatula, or any other metal tool to scrape stainless steel. Scratches are almost impossible to remove.

## 7. TROUBLESHOOTING

Only a Factory Authorized Service Representative or a local service company specializing in hotel and restaurant cooking appliances may carry out these troubleshooting procedures. The problems and possible solutions given below cover those most commonly encountered.

**FACTORY APPROVAL MUST BE OBTAINED PRIOR TO ANY WARRANTY WORK BEING DONE OR DEAN INDUSTRIES CANNOT BE HELD RESPONSIBLE.**

PROBLEM	CORRECTIVE ACTION
<b>Pilot will not ignite; no evidence of gas at pilot burner.</b>	<ol style="list-style-type: none"> <li>1. Ensure the combination gas valve is open and that gas is available at the control.</li> <li>2. Remove pilot gas supply line and check for dirt. Blow out with compressed air if necessary, then reinstall.</li> <li>3. Check pilot burner orifice for dirt.</li> </ol>
<b>Pilot burner ignites but will not remain lit when gas knob is released.</b>	<ol style="list-style-type: none"> <li>1. Check that the lead from the thermocouple is tightly screwed into the pilotstat power bushing on the gas control.</li> <li>2. Remove end of thermocouple lead from pilotstat power unit bushing and clean with fine sandpaper. Also check that bushing is clean.</li> <li>3. Thermocouple possibly defective; replace.</li> <li>4. Pilot flame may be either too high or too low. Adjust flame by turning pilot flow adjustment.</li> <li>5. Pilot flame of proper size but unstable. Flame wavers and does not envelop the thermocouple completely at all times. Check for drafts, which might be caused by air conditioning equipment or make-up air apparatus. Turn air units off and re-check the pilot.</li> </ol>
<b>Pilot burner ignites properly and burns properly, but goes out when the exhaust blower comes on.</b>	<ol style="list-style-type: none"> <li>1. Pilot flame may be adjusted too low, even though it appears to be satisfactory. Remove pilot adjustment cover screw. Adjust the pilot flame to extend approximately 1/2" above the top of the pilot burner. Replace cover screw.</li> <li>2. Pilot flame may be adjusted too high and is on the verge of blowing out. Remove pilot adjustment cover screw. Adjust the pilot flame to extend approximately 1/2" above the top of the pilot burner. Replace cover screw.</li> <li>3. With the exhaust blower in operation, the extra air causes the pilot to blow out. Adjust pilot flame lower.</li> </ol>

PROBLEM	CORRECTIVE ACTION
<p><b>Main burner will not come on even though air blower is in operation; no gas pressure at main burner.</b></p>	<ol style="list-style-type: none"> <li>1. Check that the combination gas valve is open.</li> <li>2. Check that the pilot is lit and is operating properly.</li> <li>3. The gas control may be defective; replace if necessary.</li> <li>4. Check high temperature safety switch. Replace if defective.</li> <li>5. Check air prover switch as follows:  Move actuating lever at switch to make sure it is not dragging in the slots (use long tool to avoid burns). If so, bend the arm carefully to clear the obstruction. Check the air prover switches for continuity and replace if defective.</li> </ol>
<p><b>Air blower is not operating, although power is present at the fryer.</b></p>	<ol style="list-style-type: none"> <li>1. Cooked product or other material may have fallen into the flue and lodged in the blower wheel, preventing it from turning. Clean out flue and blower wheel.</li> <li>2. Blower motor may have overheated and shut off on thermal overload. This condition will correct itself when motor cools (20 minutes). If problems with blower overheating persist, call for service.</li> <li>3. If fryer is equipped with a Thermatron Controller, the temperature probe or the Thermatron board may be defective. Call for service.</li> </ol>
<p><b>Main burner flames are small and appear lazy; Frying compound does not come up to temperature quickly.</b></p>	<ol style="list-style-type: none"> <li>1. Check gas pressure at the pressure tap of the gas control. Use a standard water-type U-gauge manometer. With the burner in operation, the pressure should be about 4" WC on natural and 11" WC on propane gases. If not, unscrew the cover of the pressure regulator adjustment, use a screwdriver to turn the adjusting screw clockwise to increase gas pressure (or counterclockwise to decrease the pressure). Replace cover and plug.</li> </ol>

<p><b>Signs of excessive fry vessel temperature; oil/shortening quickly becomes discolored.</b></p>	<ol style="list-style-type: none"> <li>1. Check operating thermostat; it may be out of calibration. Re-calibrate in accordance with instructions packaged with thermostat.</li> <li>2. Check gas pressure.</li> <li>3. Cooking compound of inferior quality or used too long. Replace with quality oil/shortening.</li> <li>4. May be a short circuit in system or problems with the Thermatron. Check wiring, Thermatron board and/or temperature probe.</li> </ol>
---	--

## 8. RECOMMENDED SPARE PARTS

To insure minimum downtime of the fryer in case the replacement of a part is required, it is recommended that one each of the following parts be kept in local stock:

High-limit control;  
Combination gas valve;  
Thermocouple;  
Operating thermostat (if applicable);  
Spark module (if so equipped).

## 9. FACTORY SERVICE & PARTS ORDERING

### 9.1 SERVICE PROBLEMS

Call the "800" number on the cover of this booklet for the location of your nearest Maintenance & Repair Center or contact the factory direct. Always give the model and serial numbers of your filter and fryer.

### 9.2 ORDERING PARTS

Customers may order parts directly from their local Authorized Parts Distributor. For this address and phone number, contact your Maintenance & Repair Center or call the factory. Factory address and phone numbers are on the cover of this booklet.

Illustration and a listing of replaceable parts follow this section.

### 9.3 Parts List: 1824G & 2424G

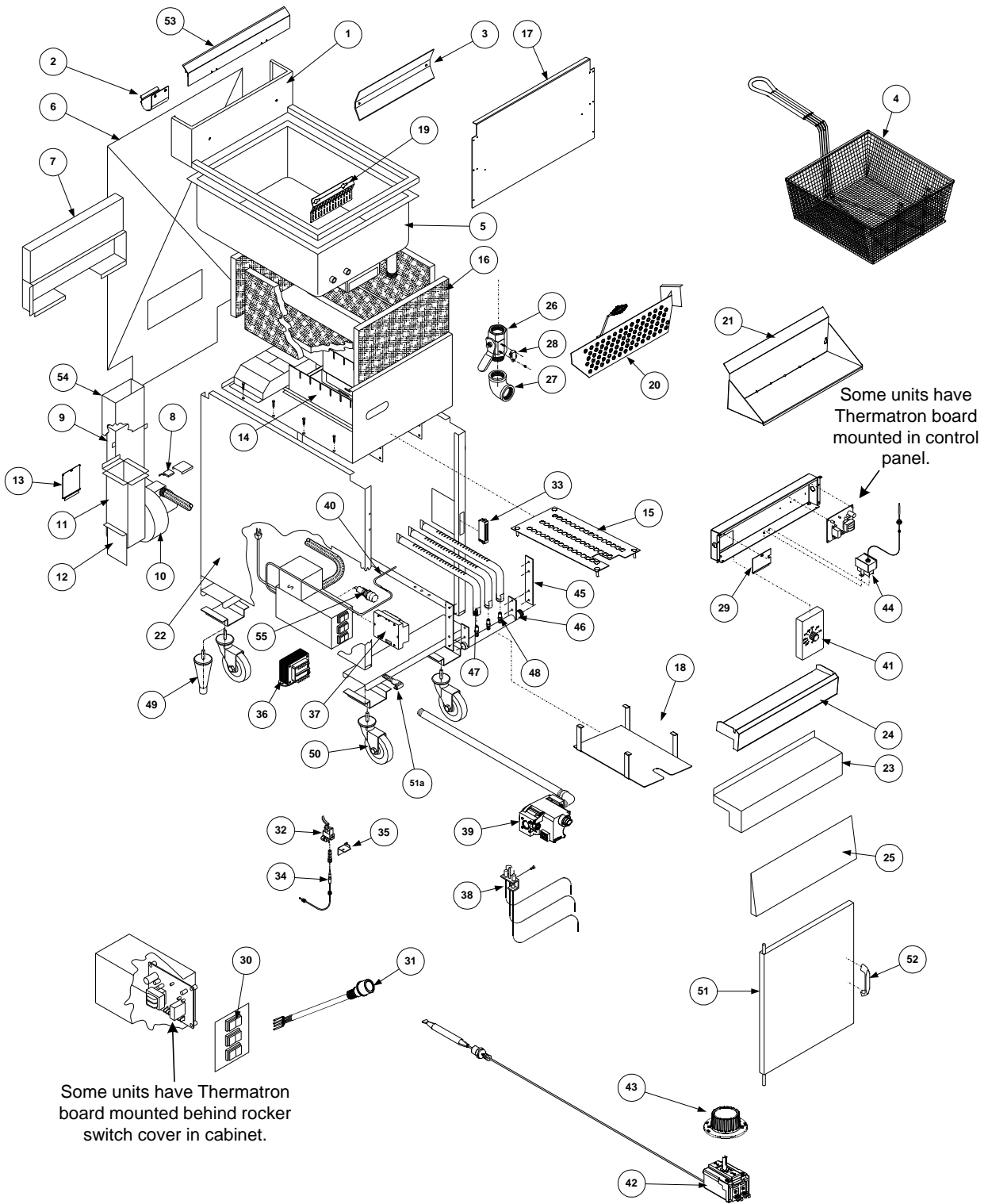



### 9.3 Parts List: 1824G & 2424G (cont.)

ITEM	COMPONENT	MODEL 1824G PART #	MODEL 2424G PART #
1	Top Assembly, Short Stack	823-3622	24248
*	Top Assembly, Std. (Old-Style High Stack)	823-3699	823-3264
*	Top Assembly, Short Stack (Old Style)	823-3577	106-1619SP
2	Hose Support, LJS Systems	210-2006	210-2006
3	Basket Hanger (Old Style)	24-0130	24-0267
4	Fry Basket, 6 x 8- <sup>3</sup> / <sub>4</sub> x 16- <sup>3</sup> / <sub>4</sub> "	803-0301	803-0301
5	Vessel, Flatbottom (Front Drain, No Filtration)	24024-1SK	24023-1SK
*	Vessel, Flatbottom (Front Drain, Front Return)	823-3507SP	823-3466SP
*	Vessel, Flatbottom (Rear Drain, Front Return)	24024-3SK	24023-3SK
6	Structural Back, Short Stack	24-0331-1	200-1607
*	Structural Back, Standard	200-1608	24-0380
7	Plenum Assembly, Short Stack	24039	24040
*	Plenum Assembly, Standard	24041	24042
8	Sail Switch (Air Prover)	11162	11162
9	Outlet Duct Assembly	823-3166	823-3166
10	Blower Motor	807-3573	807-3573
11	Inlet Duct Assembly	823-3162	823-3162
12	Airgate- Inlet Duct Assembly	200-1428	200-1428
13	Duct, Door Access	210-1365	210-1365
14	Spreader, Side Flame	210-1409	210-1409
15	Baffle, Secondary Air	823-3190	823-3190
16	Insulation, Inswool	816-0535	816-0535
17	Back, Fire Box	200-2731	200-1391
18	Guard, Fire	823-3170	823-3170
19	Guard, Temperature/High-Limit Probe	200-1411	200-1411
20	Divider, Vessel	24103	24103
21	Tray, Crumb	24003	823-3189
22	Panel, Side- LH	823-3168	823-3168
*	Panel, Side- RH	823-3169	823-3169
23	Top Cap (Canopy)	210-2028	210-1438
24	Marine Edge, Dual	N/A	24269
*	Marine Edge, Single	823-3497	823-3195
*	Marine Edge, 1824 To 1824	24255	N/A
*	Marine Edge, 2424 To 2424	N/A	823-3718
*	Marine Edge, 1824 To 2424	24257	24257
25	Panel, Control (Red Light/Green Light)	210-2471	210-2614
*	Panel, Control	210-1655	24-0080-3
26	Valve, Drain, 1- <sup>1</sup> / <sub>4</sub> " (1" Standard Port)	810-2052	810-2052
*	Valve, Drain, 1- <sup>1</sup> / <sub>4</sub> " With Microswitch Holder	823-3463	823-3463
27	Elbow, 1- <sup>1</sup> / <sub>4</sub> " NPT	813-0070	813-0070
28	Microswitch, Drain Valve	810-2103	810-2103
*	Holder, Microswitch	200-1603	200-1603
*	Screw, 4-40 x 1" Slotted Head	809-0846	809-0846
29	Cover, Thermostat Entry	200-1671	200-1671
30	Switch, Power- Green (Carling)	807-3574	807-3574
*	Switch, Rocker- Red (Old Applications)	1680	1680

\* Not Illustrated

**9.3 Parts List: 1824G & 2424G (cont.)**

<b>ITEM</b>	<b>COMPONENT</b>	<b>MODEL 1824G PART #</b>	<b>MODEL 2424G PART #</b>
31	Switch, Oil-Tight Assembly	44382	44382
*	Switch, Reset (Carling)	807-3576	807-3576
*	Plug, Switch Hole	807-3575	807-3575
*	Cover, Thermatron Entry	24-0015	24-0015
32	Pilot, Burner Assembly- Natural	106-0849SP	106-0849SP
*	Pilot, Burner Assembly- Propane (LP)	24153	24153
33	Magnet, Door Catch	810-0066	810-0066
34	Thermocouple	807-3550	807-3550
35	Bracket, Pilot Support	200-1416	200-1416
36	Transformer, Electronic Ignition	807-3551	807-3551
37	Ignition Module	807-3554	807-3554
*	Ignition Cable	106-1644SP	106-1644SP
*	Ignition Cable, Fenwall	1908	1908
38	Ignitor/Sensor Assembly (Retrofit)	106-1983SP	106-1983SP
*	Sensor Wire	106-1645SP	106-1645SP
39	Gas Valve- 24V- Natural	807-3555	807-3555
*	Gas Valve- 24V- Propane (LP)	807-3690	807-3690
*	Gas Valve- 120V- Natural	810-2156	810-2156
*	Gas Valve- 120V- Propane (LP)	810-2323	810-2323
40	Sensor Probe Assembly (G0 Board)	106-0882SP	106-0882SP
*	RTD Sensor Probe (Old-Style Thermatron)	106-1977SP	106-1977SP
41	Face Plate (Thermatron- SCF/UFF)	820-0135	820-0135
*	Face Plate (Thermatron- Single Unit)	820-0136	820-0136
*	Thermatron Retro Kit	24233-1	24233-1
*	Potentiometer Assembly, G0	807-3536	807-3536
*	Interface Board (G0 Thermatron) 115VAC	807-3566	807-3566
*	Knob, G0 (Thermatron) Control	816-0534	816-0534
42	Thermostat, Operating	807-3515	807-3515
43	Knob, Operating Thermostat	816-0546	816-0546
44	Thermostat, High-Limit- 435°F Man. Reset	807-3559	807-3559
*	Thermostat, High-Limit- 435°F Auto Reset	807-3516	807-3516
45	Support, Manifold- Left- and Right-Hand	200-1670	200-1670
46	Manifold Assembly, Gas	810-2168	810-2168
*	Plug, 1/8" NPT- Square Head	813-0705	813-0705
47	Burners, Tube	810-2129	810-2129
48	Orifice, Natural Gas	810-2051	810-2051
*	Orifice, Propane (LP) Gas	810-2317	810-2317
49	Leg	1731-2	1731-2
50	Caster, With Brake (Single Stud)	1942	1942
*	Caster, Without Brake (Single Stud)	1943	1943
*	Caster, Swivel-5" with Brake (4-Hole)	810-0357	810-0357
*	Caster, Swivel-5" w/o Brake (4-Hole)	810-0356	810-0356
*	Caster, 5" rigid (4-hole)	810-0378	810-0378
51	Door Assembly, 12/90-12/93	24270	24271
*	Door Assembly, After 1993	210-2002	210-2001
*	Door Pin (Required With 12/90 - Current)	210-2119	210-2119
*	Door Assembly, SCF	N/A	24274
*	Door Assembly, Lexington Models	106-1751SP	106-1649SP
*	Door Assembly- Prior to 12/90 (Welded Door Pins)	24019	24020
51a	Hinge Bracket, Lower	200-1675	200-1675
52	Handle, Door (With Screws)	810-2105	810-2105

\* Not Illustrated

**9.3 Parts List: 1824G & 2424G (cont.)**

<b>ITEM</b>	<b>COMPONENT</b>	<b>MODEL 1824G PART #</b>	<b>MODEL 2424G PART #</b>
53	Deflector Assembly	823-3579	823-3474
54	Flue Extension	24360	24360
55	Fuse Holder	807-1321	807-1321
*	Fuse, 2 Amp	807-3592	807-3592
<b>Additional Components Not Illustrated</b>			
*	Bracket, Batter Pan	24-0097	24-0098
*	Cover, Vessel	106-1264SP	106-1620SP
*	Bracket, Mercury Switch	24-0256	24-0256
*	Clamp, Mercury Switch/Probe	210-2620	210-2620
*	Switch, Mercury	44900	44900
*	Transformer, 24V	807-3571	807-3571
*	Circuit Breaker	807-3577	807-3577
* Not Illustrated			

# 10. SPECIFICATIONS



## 1824G

20"  
 33"  
 45"  
 35"  
 18 x 24"  
 45 – 70 Lbs.  
 120,000  
 120V/60/~1Ø – 2.0A

OVERALL WIDTH  
 OVERALL DEPTH  
 OVERALL HEIGHT  
 WORK HEIGHT  
 FRYING AREA  
 OIL CAPACITY  
 GAS RATING – BTU  
 ELECTRICAL RATING

## 2424G

26"  
 33"  
 45"  
 35"  
 24 x 24"  
 65 – 90 Lbs.  
 120,000  
 120V/60/~1Ø – 2.0A

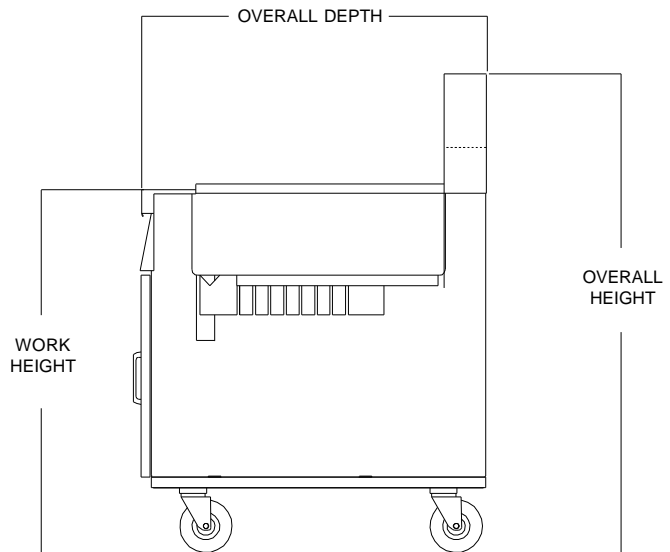
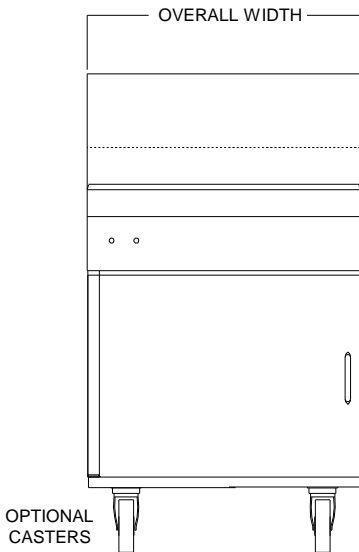

## MODELS 1824G & 2424G GAS FRYERS

# 11. WIRING DIAGRAMS

## WIRING - FRYER WITH THERMOSTAT

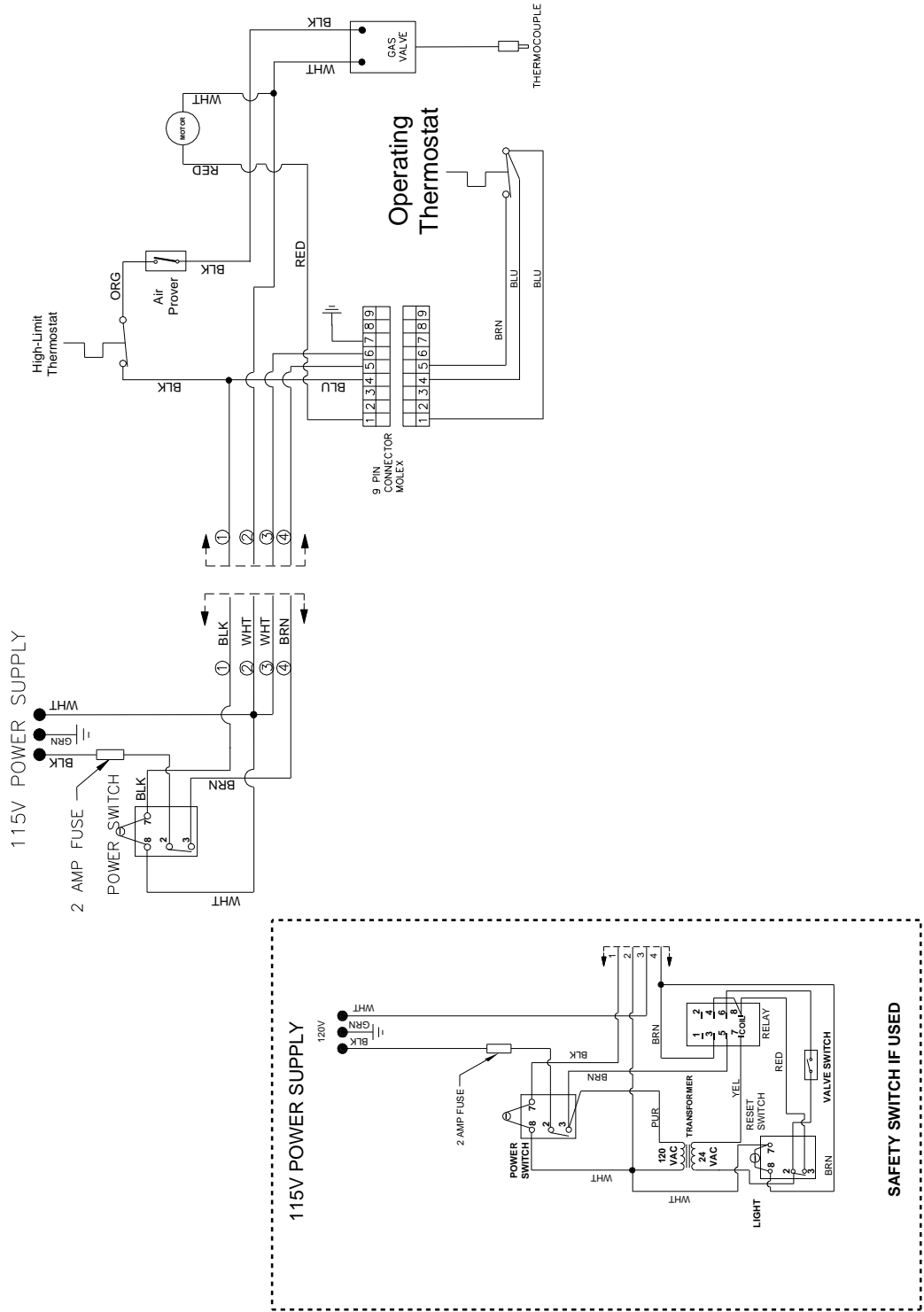

# 11. WIRING DIAGRAMS (cont.)

## WIRING - FRYER WITH THERMATRON

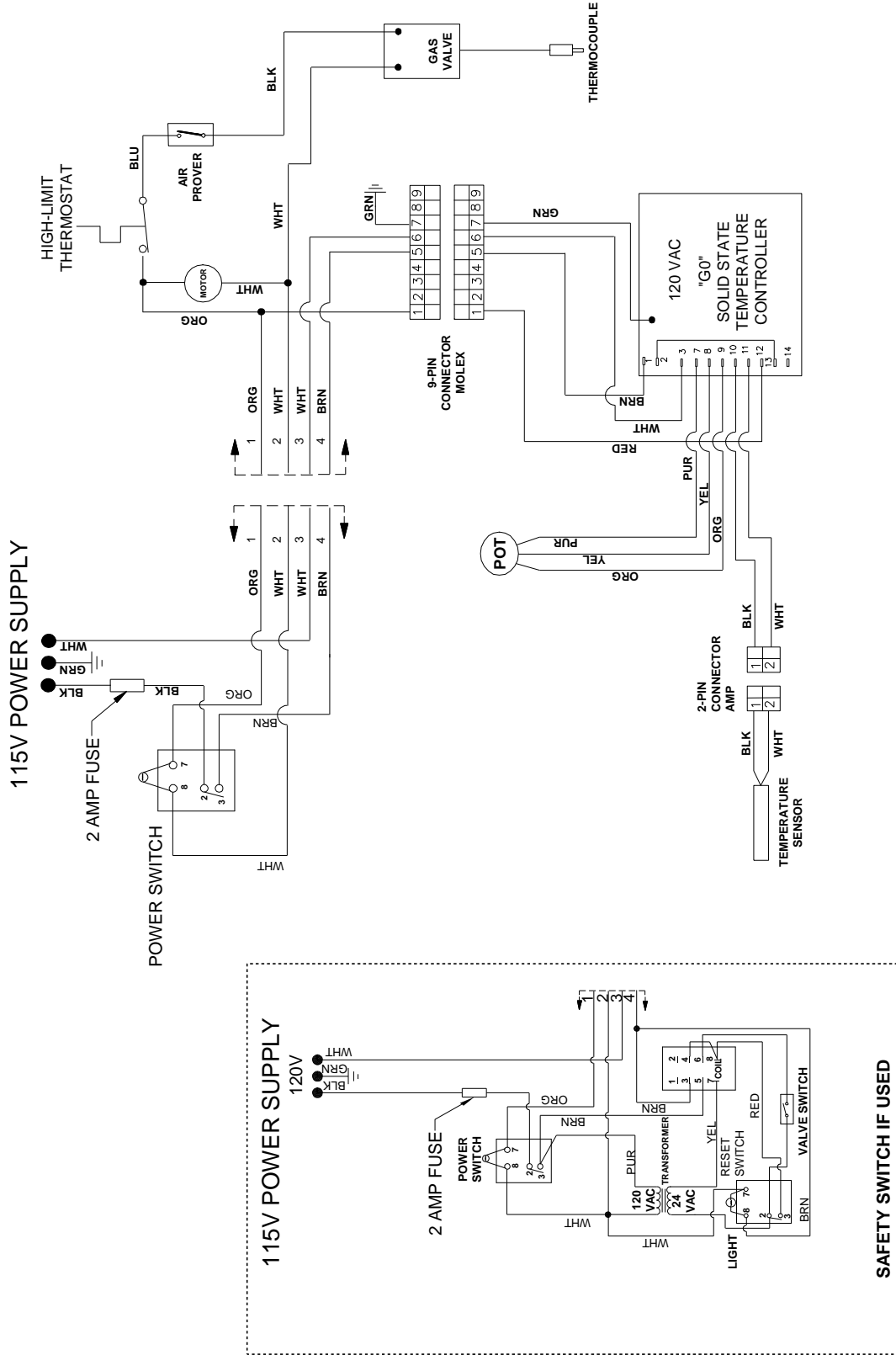

# 11. WIRING DIAGRAMS (cont.)

## WIRING - FRYER WITH THERMOSTAT - ELECTRONIC IGNITION

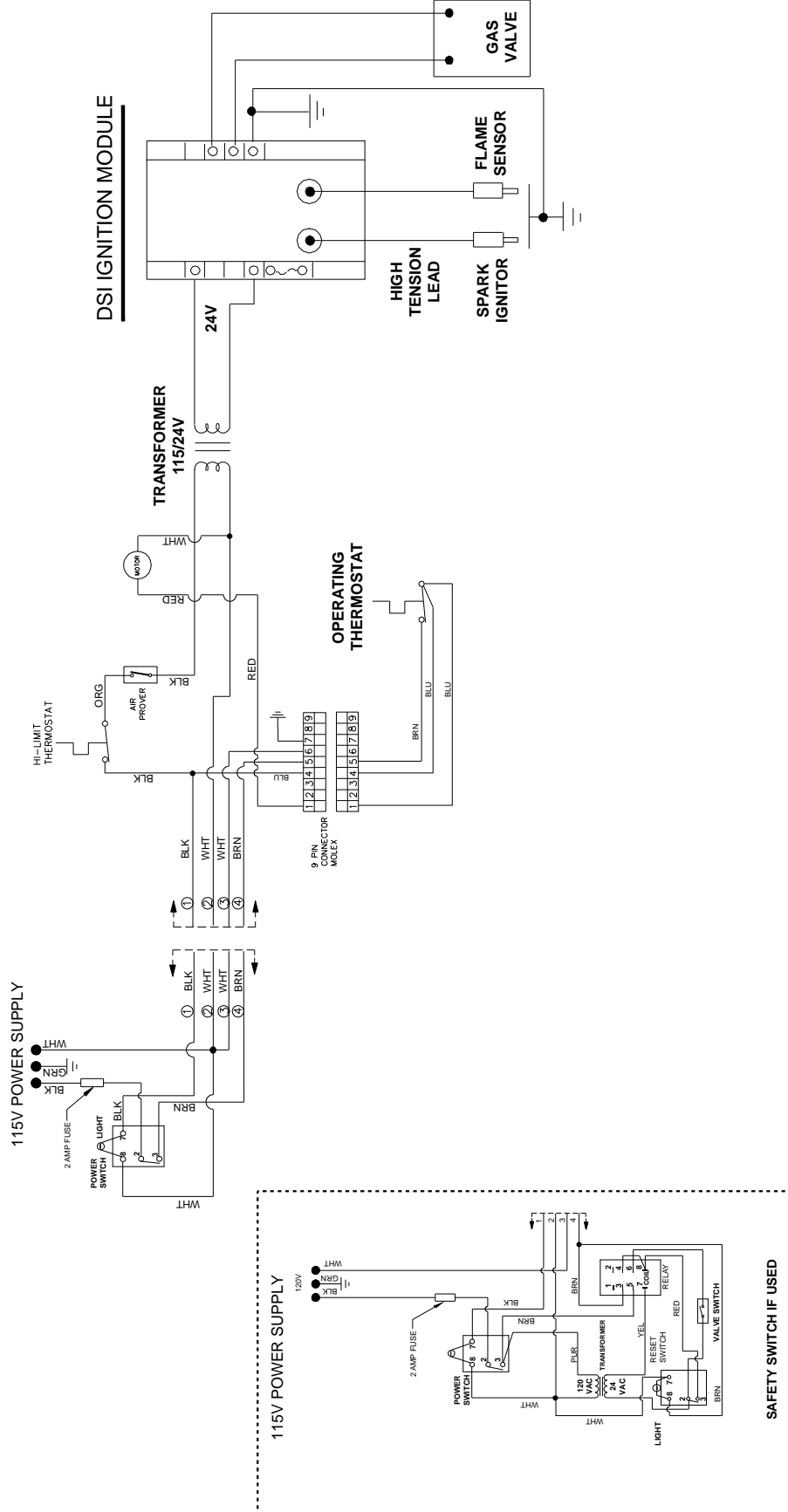

# 11. WIRING DIAGRAMS (cont.)

## WIRING - FRYER WITH THERMATRON - ELECTRONIC IGNITION

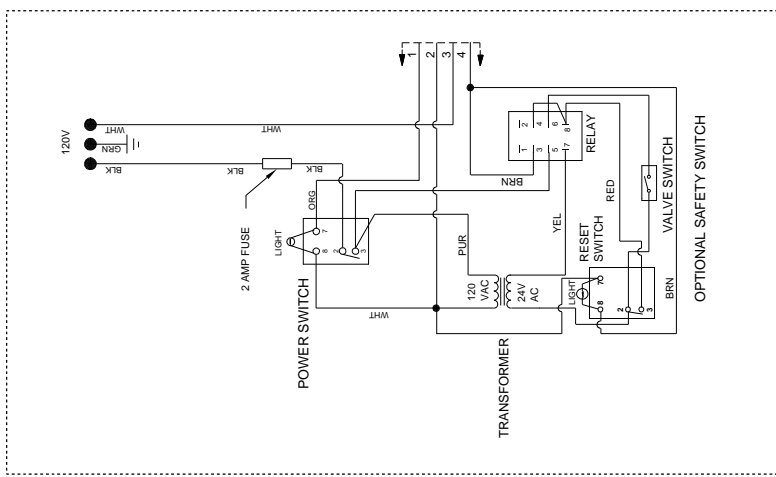
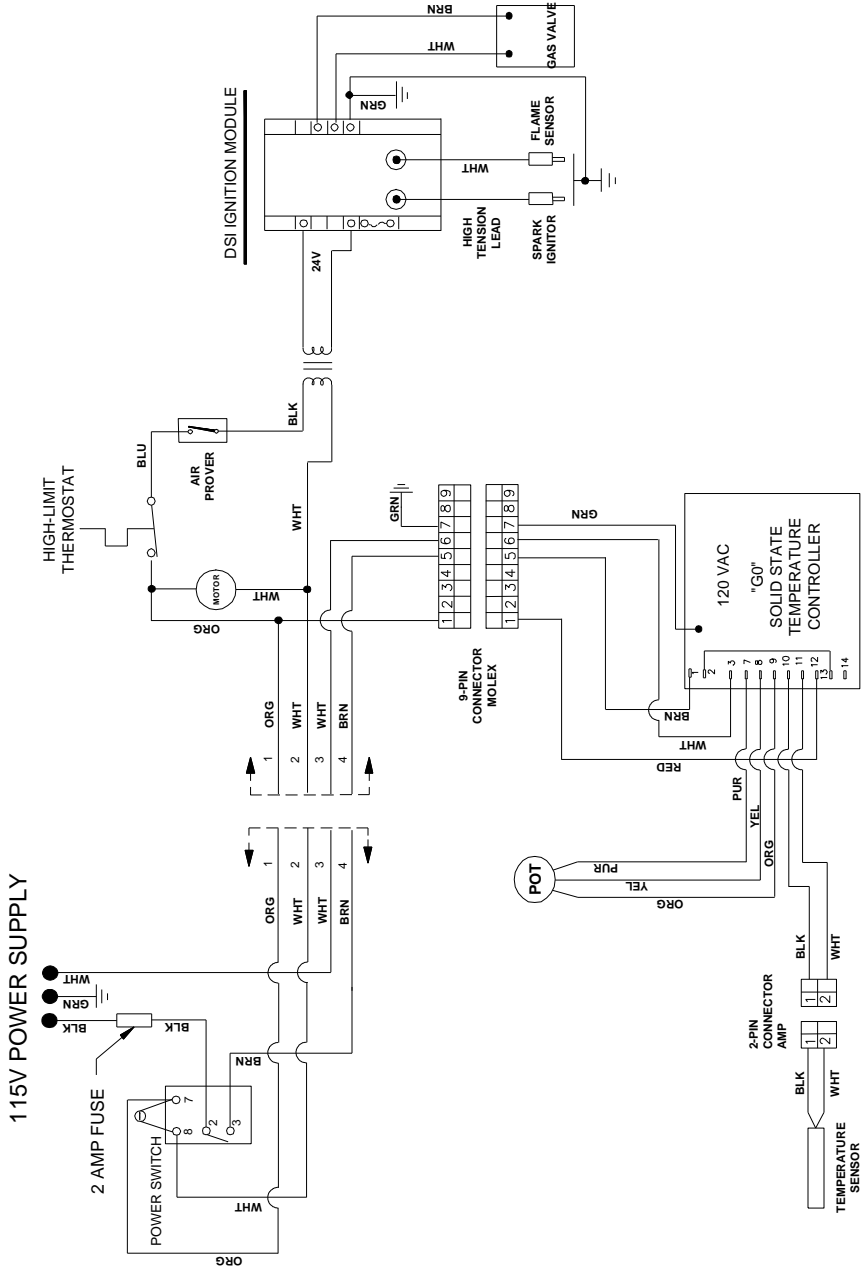





Dean, 8700 Line Avenue, PO Box 51000, Shreveport, Louisiana 71135-1000  
Shipping Address: 8700 Line Avenue, Shreveport, Louisiana 71106

TEL 1-318-865-1711

FAX (Parts) 1-310-327-3343

FAX (Tech Support) 1-318-219-7135

PRINTED IN THE UNITED STATES

SERVICE HOTLINE  
1-800-551-8633

Price: \$6.00  
819-5697 12-01