

OPERATOR'S MANUAL
McDonald's *SinBAD* Series
SINGLE BASKET DISPENSER



This document is to be inserted
into the Non-Fryer Section of
the *Equipment Manual*.

FOR YOUR SAFETY
Do not store or use gasoline or other
flammable liquids and vapors in the
vicinity of this or any other appliance.

MANUFACTURED FOR
McDONALD'S®
BY FRYMASTER, L.L.C.
8700 LINE AVE.
SHREVEPORT, LOUISIANA 71106
PHONE 1 (318) 865-1711
1 (800) 24 FRYER

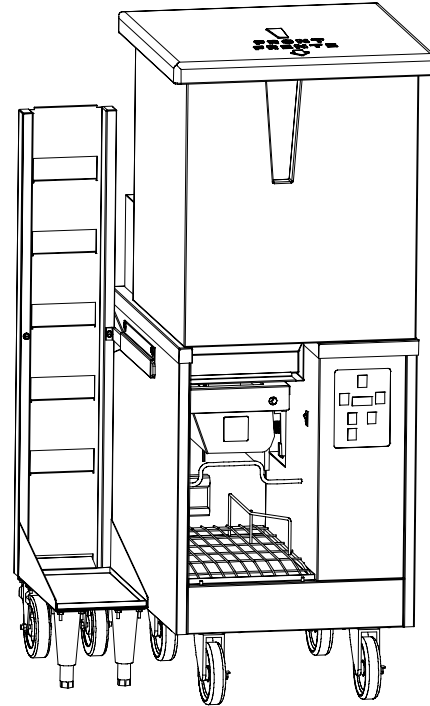

TABLE OF CONTENTS

WARRANTY STATEMENT Page i
INTRODUCTION.....Page 1-1
INSTALLATION AND OPERATIONPage 2-1
MAINTENANCE AND OPERATOR TROUBLESHOOTINGPage 3-1

Frymaster L.L.C., 8700 Line Avenue, Shreveport, Louisiana 71106

TEL 318-865-1711 FAX (Parts) 318-219-7140 (Tech Support) 318-219-7135

 **DANGER**

IMPROPER INSTALLATION, ADJUSTMENT, ALTERATION, SERVICE OR MAINTENANCE CAN CAUSE PROPERTY DAMAGE, INJURY, OR DEATH. READ THE INSTALLATION, OPERATING, AND MAINTENANCE INSTRUCTIONS THOROUGHLY BEFORE INSTALLING, OPERATING, OR SERVICING THIS EQUIPMENT.

 **DANGER**

DO NOT ATTEMPT TO REPAIR OR REPLACE ANY COMPONENT OF THIS EQUIPMENT UNLESS ALL POWER TO THE EQUIPMENT HAS BEEN DISCONNECTED.

 **DANGER**

FOR YOUR SAFETY, DO NOT STORE OR USE GASOLINE OR OTHER FLAMMABLE VAPORS AND LIQUIDS IN THE VICINITY OF THIS OR ANY OTHER APPLIANCE.

 **DANGER**

FRYMASTER EQUIPMENT IS MANUFACTURED FOR USE WITH THE TYPE VOLTAGE SPECIFIED ON THE EQUIPMENT RATING PLATE. FOR PROPER ELECTRICAL INSTALLATION PROCEDURES IN THE UNITED STATES, REFER TO THE LATEST EDITION OF THE NATIONAL ELECTRIC CODE (ANSI/N.F.P.A. NO 70). IN CANADA, REFER TO THE CANADIAN ELECTRICAL CODE PART 1 (CSA-22.1.) FOR INSTALLATION IN COUNTRIES OTHER THAN THE UNITED STATES AND CANADA, REFER TO THE NATIONAL CODE APPROPRIATE FOR THE COUNTRY IN WHICH THE EQUIPMENT IS BEING INSTALLED.

 **WARNING**

DO NOT OPERATE THIS EQUIPMENT UNLESS ALL SERVICE AND ACCESS PANELS ARE IN PLACE AND PROPERLY SECURED.

 **WARNING**

COMPUTERS

FCC

This device complies with Part 15 of the FCC rules. Operation is subject to the following two conditions: 1) This device may not cause harmful interference, and 2) This device must accept any interference received, including interference that may cause undesired operation. While this device is a verified Class A device, it has been shown to meet the Class B limits.

CANADA

This digital apparatus does not exceed the Class A or B limits for radio noise emissions as set out by the ICES-003 standard of the Canadian Department of Communications.

Cet appareil numérique n'émet pas de bruits radioélectriques dépassant les limites de classe a et b prescrites dans la norme NMB-003 édictée par le ministre des communications du Canada.

HAZARD COMMUNICATION STANDARD (HCS) – WHEN THE PROCEDURES IN THIS MANUAL INCLUDE THE USE OF CHEMICAL PRODUCTS, THE PRODUCTS WILL BE PRINTED IN BOLD FACE, FOLLOWED BY THE ABBREVIATION **HCS** IN THE TEXT PORTION OF THE PROCEDURE. SEE THE HAZARD COMMUNICATION STANDARD (HCS) MANUAL FOR THE APPROPRIATE MATERIAL SAFETY DATA SHEET (MSDS).

McDonald's SINGLE BASKET DISPENSER

CHAPTER 1: INTRODUCTION

1.1 Parts Ordering and Service Information

In order to assist you as quickly as possible, the Frymaster Factory Authorized Servicer (FAS) or Service Department representative requires certain specific information about your equipment. Most of this information is printed on a data plate affixed to the upper right corner of the right side of your unit.

Parts orders may be placed directly with your local FAS or distributor. A list of Frymaster Factory Authorized Servicers (FAS's) is located on the Frymaster website at www.frymaster.com. If you do not have access to this list, contact the Frymaster Service Department at 1-800-24-FRYER.

When ordering parts, the following information is required:

Model Number: _____
Serial Number: _____
Voltage: _____
Item Part Number: _____
Quantity Needed: _____

Service information may be obtained by contacting your local FAS or Distributor. Service may also be obtained by calling the Frymaster Service Department at 1-800-24-FRYER.

When requesting service, please have the following information ready:

Model Number: _____
Serial Number: _____
Voltage: _____

In addition to the model number, serial number, and voltage, please be prepared to describe the nature of the problem and have ready any other information that you think may be helpful in solving your problem.

1.2 Safety Information

Before attempting to operate your unit, read the instructions in this manual thoroughly. Throughout this manual, you will find notations enclosed in double-bordered boxes similar to the one below.



CAUTION boxes contain information about actions or conditions that *may cause or result in a malfunction of your unit*.

WARNING boxes contain information about actions or conditions that *may cause or result in damage to your unit*, and which may cause your unit to malfunction.

DANGER boxes contain information about actions or conditions that *may cause or result in injury to personnel*, and which may cause damage to your unit and/or cause your unit to malfunction.

1.3 Equipment Description

The McDonald's Single Basket Dispenser (*SinBaD*) is designed to dispense french fries in batches of consistent weight into standard fryer baskets.

A *SinBaD* unit consists of

- a hopper which holds up to 39 lbs./17.5 kg of fries
- a dispensing chute into which the specified weight of fries for one basket is loaded
- a computer and an operator control panel for controlling operation
- a proximity switch which releases the fries into the basket when the basket is inserted beneath the dispensing chute
- a sight-glass for monitoring the level of french fries in the hopper.

Additionally, the unit is equipped with casters. The front casters are equipped with locking mechanisms to secure the units in place.

The *SinBaD* Batch Weight Selectors have been factory-programmed to dispense batches of three standard sizes: 0.5 lb./23 kg, 1.0 lb./45 kg, or 1.5 lb./68 kg.

1.4 Installation, Operating, and Service Personnel

Operating information for Frymaster equipment has been prepared for use by qualified and/or authorized personnel only, as defined in Section 1.5.

All installation and service on Frymaster equipment must be performed by qualified, certified, licensed, and/or authorized installation or service personnel, as defined in Section 1.5.

1.5 Definitions

QUALIFIED AND/OR AUTHORIZED OPERATING PERSONNEL

Qualified/authorized operating personnel are those who have carefully read the information in this manual and have familiarized themselves with the equipment functions, or who have had previous experience with the operation of the equipment covered in this manual.

QUALIFIED INSTALLATION PERSONNEL

Qualified installation personnel are individuals, firms, corporations, or companies which, either in person or through a representative, are engaged in and are responsible for the installation of commercial electric appliances. Qualified personnel must be experienced in such work, be familiar with all electrical precautions involved, and have complied with all requirements of applicable national and local codes.

QUALIFIED SERVICE PERSONNEL

Qualified service personnel are those that are familiar with Frymaster equipment and who have been authorized by Frymaster to perform service on its equipment. All authorized service personnel are required to be equipped with a complete set of service and parts manuals, and to stock a minimum amount of parts for Frymaster equipment.

A list of Factory Authorized Servicers (FASs) is located on the Frymaster website at www.frymaster.com. ***Failure to use qualified service personnel will void the warranty on your equipment.***

1.6 Shipping Damage Claim Procedure

Your equipment was carefully inspected and packed before leaving the factory. The transportation company assumes full responsibility for safe delivery upon its acceptance of the equipment for transport.

What to do if your equipment arrives damaged:

1. **File a claim for damages immediately**, regardless of the extent of damages.
2. **Inspect for and record all visible loss or damage**, and ensure that this information is noted on the freight bill or express receipt and is signed by the person making the delivery.
3. **Concealed loss or damage** that was unnoticed until the equipment was unpacked should be recorded and reported to the freight company or carrier **immediately** upon discovery. A concealed damage claim must be submitted within 15 days of the date of delivery. Ensure that the shipping container is retained for inspection.

**FRYMASTER DOES NOT ASSUME RESPONSIBILITY FOR DAMAGE OR
LOSS INCURRED IN TRANSIT.**

McDonald's *SinBaD* SINGLE BASKET DISPENSER

CHAPTER 2: INSTALLATION AND OPERATION

FINDING YOUR WAY AROUND YOUR NEW *SinBaD* UNIT

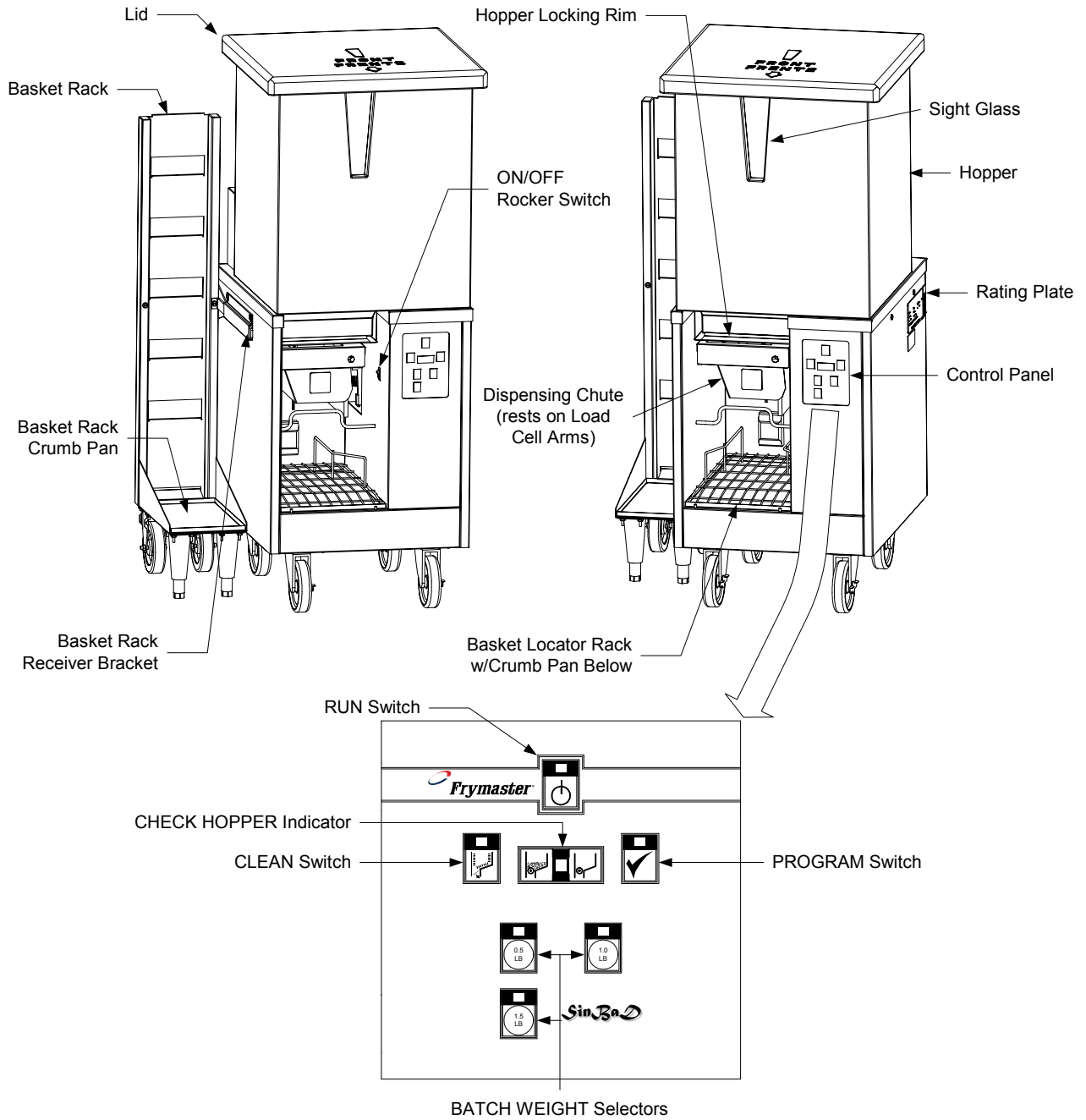

2.1 Installation

⚠ DANGER

All electrically operated appliances must be electrically grounded in accordance with local codes, or in the absence of local codes, with the applicable national electrical code. If this appliance is equipped with a three-prong grounding plug for your protection against electrical shock hazard, it must be plugged directly into a properly grounded three-prong receptacle. **DO NOT CUT OFF OR REMOVE THE GROUNDING PRONG FROM THIS PLUG.**

⚠ DANGER

This appliance is intended for indoor use only. **IT IS NOT SUITABLE FOR OUTDOOR USE.**

⚠ DANGER

This appliance is not suitable for installation in an area where a water jet could be used.

⚠ DANGER

This appliance must be installed on a horizontal surface, i.e., a surface having a slope of less than 2°.

⚠ CAUTION

For proper operation, this appliance should be installed in an area having an ambient temperature within the range 40° – 110°F (4° – 43°C).

Locate the unit in an area where it will not be bumped or jarred during normal activities. Movement of the unit during operation may cause inaccurate filling of the dispensing chute.

1. Position the cabinet assembly on a horizontal surface adjacent to an AC outlet of appropriate voltage (refer to the data plate affixed to the upper right corner of the right side of the unit).
2. Attach the receiver bracket to the desired side of the unit. Attach the basket rack arm to the rack on the side corresponding to the receiver bracket. Attach the basket rack assembly to the unit by inserting the arm into the receiver bracket. Place the basket rack crumb pan onto the base of the rack.

⚠ CAUTION

Do not use the basket rack unless it has been properly attached to the cabinet.

3. Assemble the hopper by inserting the drum into the hole at the rear of the hopper with the hole in the drum facing out. Position the lip of the deflector over the left edge of the hopper, and insert the sight glass into the V-shaped opening at the front of the hopper.
4. Place the hopper on top of the cabinet with the sight glass to the front. Position the hopper so that the drum rotator is inserted into the hole in the drum, the hopper is sitting flat on the cabinet top, and its lower front edge is seated behind the locking rim of the cradle assembly (see illustration on Page 2-1). Place the lid onto the hopper, making sure the arrow on the lid points to the front of the unit.
5. Place the crumb pan onto the lower deck behind the two studs. Position the basket locator rack into the pan with the legs at the rear (see illustration on Page 2-1).

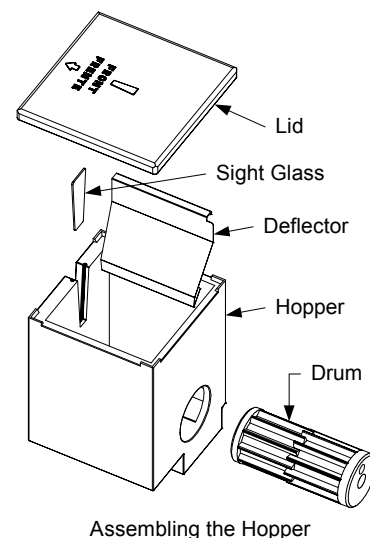

6. Make any final positioning adjustments necessary, then lock the casters and connect the unit to an appropriate electrical source. **If this equipment is wired directly into the electrical power supply, a means for disconnection from the supply having a contact separation of at least 3 mm in all poles must be incorporated in the fixed wiring.**
7. Once the unit has been positioned, and connected, remove the load cell shipping protector. **The load cell shipping protector consists of a bolt, red wingnut, shim, and large red tag. The bolt and shim MUST be removed for proper operation.**

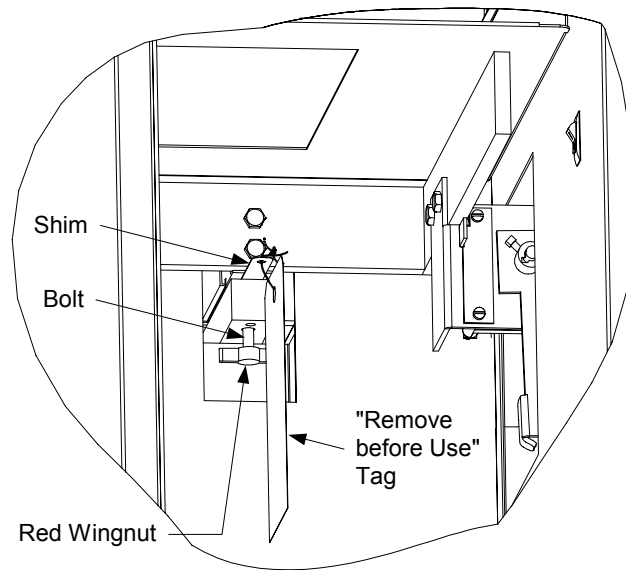

This bolt (with attached red wingnut) and shim are used to protect the load cell during shipment. They must be removed before the unit will work properly.

2.2 Self-Zeroing

The **SinBoD** unit is self-zeroing. Each time the unit is placed in the RUN mode, it performs a self-zeroing routine. The routine is characterized by the Dispensing Chute door opening for about 20 seconds and the sequential flashing of the batch weight selector lights. The door will close and the lights will stop flashing when the self-zeroing routine is complete.

2.3 Operation

⚠ CAUTION
Ensure the ON/OFF Rocker Switch is in the OFF position before installing the hopper.

1. Verify that the ON/OFF Rocker Switch is in the “OFF” position.
2. Verify that the crumb pan is properly inserted in the deck cutout.
3. Verify that the basket locator rack is properly positioned with the wide end facing you.
4. Verify that the dispensing chute is properly positioned on the load cell arms, with the door hinge screws to the right as you face the unit. Failure to properly position the chute will result in erratic batch weights.

5. Verify that the drum and deflector are properly positioned inside the hopper. Failure to do so will result in a malfunction of your unit. If the deflector is deformed (i.e., bent or distorted), a malfunction of your unit is likely.

 **DANGER**

A pinch-point exists between the drum and hopper when the drum is turning. When removing or installing the deflector or dispensing chute, place the ON/OFF Rocker Switch in the “OFF” position.

6. Verify that the hopper is properly positioned in its cradle. Make sure that the hopper is seated behind the locking rim on the cradle. Failure to do so will result in malfunctioning of your unit.
7. Verify that the sight glass is installed. If it is not installed, fries will fall out of the hopper during operation.
8. Place the ON/OFF Rocker Switch in the ON position. The switch will illuminate, indicating that electrical power is being supplied to the unit.
9. Press the RUN Switch  once to place the unit in the RUN mode. The indicator light in the switch will illuminate. The dispensing chute door will open as the unit begins self-calibration and the lights in the batch weight selectors will sequentially flash. The door will close about 20 seconds later and the lights will stop flashing when calibration is completed. Only the RUN mode indicator will be illuminated.
10. Open the hopper lid and load up to 42 lbs/19 kg of French fries into the hopper. Close the hopper lid.
11. Press the BATCH WEIGHT Selector that corresponds to the desired weight of potatoes. The factory-programmed weights are 0.5 lb/.23 kg, 1.0 lb/.45 kg, and 1.5 lb/.68 kg (see illustration on Page 2-1).

The indicator light in the selector will illuminate and the drum will begin to rotate, transferring fries from the hopper to the dispensing chute. When the prescribed weight has been transferred, drum rotation will cease.



12. Insert an empty basket all the way to the rear of the dispensing chamber. The dispensing chute door will open, dropping the fries into the basket. When the chute is empty, the door will close and the unit will begin to transfer another batch of fries into the chute.

 **CAUTION**

The dispensing of fries into a basket is initiated by an inductive proximity switch located in the dispensing well. The proximity switch activates only when it senses a metallic mass greater than a certain size (e.g., an inserted basket). Thus, it will not be activated by the operator’s hand, a cleaning cloth, or any other non-metallic object. However, a ring, watch or some other type of metal could initiate a dispense cycle if inserted into the switch detection area.



NOTE: Built-in logic recognizes the removal and replacement of the basket. Once a dispense cycle has been completed, another basket may be inserted into the dispense well. As soon as the fries in the chute reach the specified weight, the unit will immediately dispense them into the waiting basket. The unit will NOT initiate another dispense cycle if the full basket is not removed and replaced, nor will it initiate another dispense cycle if there is no basket in the dispense well.

To change the batch weight, press another of the numbered selectors before the chute is emptied. If the weight is increased, fries will be dispensed until the new weight is attained. If the batch weight is reduced, the change will take effect with the next cycle after the dispensing chute is emptied.

If the dispensing chute does not fill within 30 seconds, the CHECK HOPPER indicator  in the middle of the control panel will begin to blink and drum rotation will stop. Check the hopper to see if it is empty. If it is empty, reload the hopper then press the PROGRAM  Switch once to place the unit back into operation. If the hopper appears to contain plenty of fries, the fries have probably “bridged” (i.e., stuck together to form an arch over the drum). Redistribute the fries then press the PROGRAM  Switch once to place the unit back into operation.

2.4 Manual Operation

If the unit fails to zero, the unit can be manually operated until a servicer arrives to make repairs. Follow the procedure below.



1. Turn the computer off (press the RUN Switch .
2. Place a basket under the hopper dispense door.
3. Press the CLEAN Switch  once to dispense fries into the basket. NOTE: If the dispense door fails to open, pull down on the door arm to manually open the door.
4. When the basket is filled to the desired level, press the CLEAN Switch  once to stop dispensing fries.

McDonald's *SinBaD* SINGLE BASKET DISPENSER

CHAPTER 3: MAINTENANCE & OPERATOR TROUBLESHOOTING

3.1 Cleaning and Maintenance

Routine cleaning in accordance with the following steps is the only operator maintenance required for your *SinBaD* unit.

1. Put the unit in STANDBY mode. Place a container beneath the dispensing chute and press the CLEAN  Switch. The indicator in the switch will light. The dispensing chute door will open and the drum will rotate, transferring fries from the hopper to the container. Press the CLEAN Switch again to stop transferring. To transfer more fries, press the CLEAN Switch again. When the hopper is empty, press the RUN Switch  once to return to the STANDBY mode. The dispensing chute door will remain open.
2. Place the ON/OFF Rocker Switch in the OFF position.
3. Remove the hopper lid and the metal deflector. Lift up on the hopper while carefully pulling it toward you. This will disengage the hopper from its retainer, allowing it to slide forward for removal.
4. Remove the dispensing chute by lifting it up from the load cell arms and carefully sliding it out toward you.

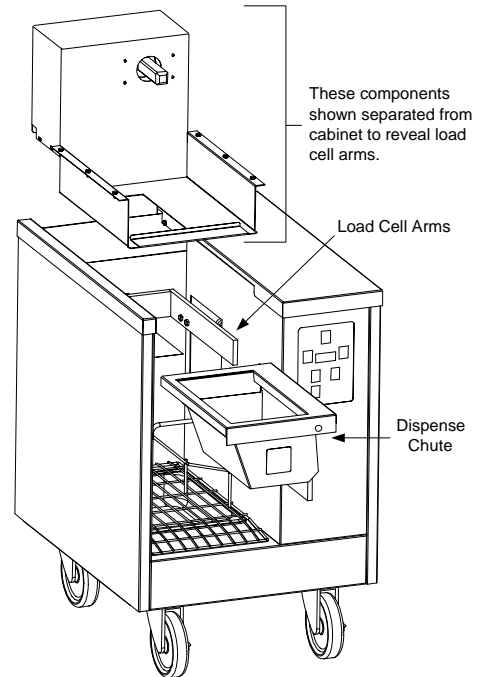

⚠ WARNING
NEVER REMOVE THE ALUMINUM LOAD CELL ARMS FROM YOUR UNIT! DOING SO CAN CAUSE SERIOUS DAMAGE TO YOUR UNIT.

5. Clean the cabinet by brushing away crumbs with a basting brush, then wiping down all exposed surfaces with a soft cloth dampened with a solution of McDonald's All Purpose Cleaner (HCS).
6. Clean the hopper and associated components by removing the hopper from the unit, disassembling the components, and washing all components with a solution of McDonald's All Purpose Cleaner (HCS). Rinse with clean water and dry thoroughly.
7. Clean the dispense chute, basket locator rack, crumb pan, and basket rack by washing them with a solution of McDonald's All Purpose Cleaner (HCS). Rinse with clean water and dry thoroughly.

⚠ DANGER!
Do not use a water jet to clean this appliance. The hopper, deflector, crumb pan, basket locator rack, dispense chute, and basket rack may be cleaned with a water jet *ONLY* if removed from the unit.



When replacing the dispensing chute, ensure that the door hinge screws are to the right as you face the unit.

3.2 Operator Troubleshooting

The operator troubleshooting guides that follow are intended to help operators resolve routine problems that may be encountered during operation of the unit.

PROBLEM	Probable Causes	Corrective Action
UNIT WILL NOT POWER UP or NOTHING HAPPENS WHEN “RUN” MODE IS SELECTED.	A. ON/OFF rocker switch is in OFF position.	A. Place rocker switch in the ON position.
	B. Unit is not plugged in.	B. Plug unit in.
	C. Main circuit breaker is tripped.	C. Reset circuit breaker.
	If the problem is not corrected by one of the above actions, call FAS.	
RUN SWITCH INDICATOR AND PROGRAM SWITCH INDICATOR ARE FLASHING.	A. Dispensing chute is not properly positioned on the load cell arms.	A. Reposition dispensing chute so that is firmly seated on the load cell arms. Turn the unit OFF then back ON using the ON/OFF rocker switch. Press the RUN switch
	Simultaneous flashing of the run switch indicator and program switch indicator signals that the unit is not properly zeroed. If the problem is not corrected by the above action, call FAS.	
NOTHING HAPPENS WHEN A BATCH SIZE SELECTOR IS PRESSED.	A. Dispensing chute is full.	A. If the dispense chute has been loaded but not dispensed, nothing will happen until the batch has been dispensed, except when the batch weight is increased. Insert a basket into the dispensing well to dispense batch.
	B. Unit is not in RUN mode.	B. Press RUN switch once.
	If one of the above actions did not correct the problem, call FAS.	
DISPENSE DOOR DOES NOT OPEN WHEN BASKET IS INSERTED.	A. The load cell may not have been satisfied within 30 seconds, normally because the hopper is empty or the fries have “bridged”.	A. Check the hopper to verify that the deflector is properly positioned. If there are fries in the hopper, verify that there is no bridging. If the hopper is empty, reload the hopper. Press the PROGRAM switch once to place the unit back into operation.
	If the above action did not correct the problem, call FAS.	
ERRATIC BATCH WEIGHTS ARE BEING DISPENSED.	A. If the erratic batch weights are occurring only occasionally, the probable cause is bumping, jarring, and/or unusual vibration (such as caused by inserting a basket with undue force, the slamming of a freezer door, or the passing of a nearby train).	A. Exercise care when working around the unit to avoid bumping or jarring it while it is in operation. Ensuring that the unit is not touching adjacent walls, and placing the unit on a rubber mat will reduce the effect of environmental vibrations.

PROBLEM	Probable Causes	Corrective Action
Continued from previous page.	B. If the erratic batch weights are occurring consistently, the probable cause is a misaligned component.	B. Verify that the dispensing chute is properly positioned on the load cell arms, that the deflector is properly positioned in the hopper, and that the hopper is fully seated behind the locking rim on the cradle assembly.
	If one of the above actions does not correct the problem, there may be a problem with the programmed weight settings or the load cell. Call FAS.	
UNIT WILL NOT GO INTO CLEAN MODE.	A. Unit was not in STANDBY mode when attempt was made to enter CLEAN mode.	A. The CLEAN mode can only be selected when the unit is in the STANDBY mode. Press the RUN Switch once to place the unit in the STANDBY mode, and then press the CLEAN Switch.
	If the above action did not correct the problem, call FAS.	