



Heated Pass Through Service and Parts

 **Frymaster**[®]



Frymaster, a member of the Commercial Food Equipment Service Association, recommends using CFESA Certified Technicians.

* 8195931 *

24-Hour Service Hotline
1-800-551-8633

Price: \$6.00
819-5931
JULY 2011

NOTICE

IF, DURING THE WARRANTY PERIOD, THE CUSTOMER USES A PART FOR THIS ENODIS EQUIPMENT OTHER THAN AN UNMODIFIED NEW OR RECYCLED PART PURCHASED DIRECTLY FROM FRYMASTER/DEAN, OR ANY OF ITS AUTHORIZED SERVICE CENTERS, AND/OR THE PART BEING USED IS MODIFIED FROM ITS ORIGINAL CONFIGURATION, THIS WARRANTY WILL BE VOID. FURTHER, FRYMASTER/DEAN AND ITS AFFILIATES WILL NOT BE LIABLE FOR ANY CLAIMS, DAMAGES OR EXPENSES INCURRED BY THE CUSTOMER WHICH ARISE DIRECTLY OR INDIRECTLY, IN WHOLE OR IN PART, DUE TO THE INSTALLATION OF ANY MODIFIED PART AND/OR PART RECEIVED FROM AN UNAUTHORIZED SERVICE CENTER.

THE HEATED PASS THROUGH IS NOT SUITABLE FOR OUTDOOR USE. WHEN OPERATING THIS UNIT, IT MUST BE PLACED ON A HORIZONTAL SURFACE.

THE HEATED PASS THROUGH IS NOT SUITABLE FOR INSTALLATION IN AN AREA WHERE A WATER JET CAN BE USED. THIS APPLIANCE MUST NOT BE CLEANED WITH A WATER JET.

FOR YOUR SAFETY

DO NOT STORE OR USE GASOLINE OR OTHER FLAMMABLE VAPORS AND LIQUIDS IN THE VICINITY OF THIS OR ANY OTHER APPLIANCE.

DO NOT OPERATE OR SERVICE THE HPT SERIES WITHOUT FIRST READING THIS MANUAL.

DO NOT OPERATE THE HPT UNLESS IT HAS BEEN PROPERLY INSTALLED AND CHECKED.

DO NOT OPERATE THE HPT UNLESS ALL SERVICE AND ACCESS PANELS ARE IN PLACE AND PROPERLY SECURED.

DO NOT ATTEMPT TO REPAIR OR REPLACE ANY COMPONENT OF THE HPT UNLESS ALL POWER TO THE UNIT HAS BEEN DISCONNECTED.

USE CAUTION WHEN SETTING UP, OPERATING, OR CLEANING THE HEATED PASS THROUGH TO AVOID CONTACT WITH HEATED SURFACES.

HEATED PASS THROUGH SERVICE AND PARTS

1. Parts Ordering and Service Information

Parts orders may be placed directly with your local Frymaster Factory Authorized Servicer (FAS)/Distributor. Your nearest Frymaster FAS's/ Distributors can also be found on Frymaster's Web site, Frymaster.com. or you can contact the Frymaster Service Department at 1-800-24-FRYER or 1-318-865-1711.

To speed up your order, the following information is required:

Model Number _____

Serial Number _____

Voltage _____

Item Part Number _____

Quantity Needed _____

Service may be obtained by contacting your local Frymaster Authorized Service Center/Distributor. Service information may be obtained by calling the Frymaster Service Department. The following information will be needed in order to assist you quickly and efficiently:

Model Number _____

Serial Number _____

Nature of the Problem _____

Also include any other information which may be helpful in solving your service problem.

RETAIN AND STORE THIS MANUAL IN THE EQUIPMENT MANUAL FOR FUTURE USE.

2. General

The *Heated Pass Through* or *HPT* is designed to hold assembled sandwiches. By circulating heated air evenly across the open staging area, the unit keeps sandwiches hot without drying or cooking.

3. Installation/Set Up

Upon arrival, inspect the HPT for concealed damage. Immediately report any damage to the delivering freight company. Claims must be filed within 15 days after receipt of the unit.

Make sure that the unit is placed on an even surface and that the area surrounding the HPT is free of clutter that would interfere with airflow.

Install the Filter Screen

The filter screen is designed to prevent debris from entering the cowl assembly and clogging the blower. Slip the part over the vent opening on the ON/OFF switch side of the unit. The filter screen snaps into position.



The filter screen snaps into place on the air-intake tower.

HEATED PASS THROUGH SERVICE AND PARTS

Power Requirements:

- Voltage – Two models: 208 VAC and 240 VAC
- Frequency - 208V/60 Hz, 240V/50-60 Hz
- Single Phase
- 20 amp Service

THIS APPLIANCE IS EQUIPPED WITH A GROUNDING PLUG FOR YOUR PROTECTION AGAINST SHOCK HAZARD AND MUST BE PLUGGED INTO A PROPERLY GROUNDED RECEPTACLE. DO NOT CUT OR REMOVE THE GROUNDING PRONG FROM THIS PLUG.

4. Operation

1. Plug the unit into the power source.
2. Press the ON/OFF rocker switch to the ON position.
3. Place product in the HPT in accordance with the restaurant's established procedures.

⚠ DANGER
If the 240 VAC model is operated on 208 VAC, the unit will heat slowly and may not reach maximum temperature. If the 208 VAC model is operated on 240 VAC, component damage is likely. To ensure proper operation, the power source should match the voltage on the rating plate on the bottom of the HLZ.

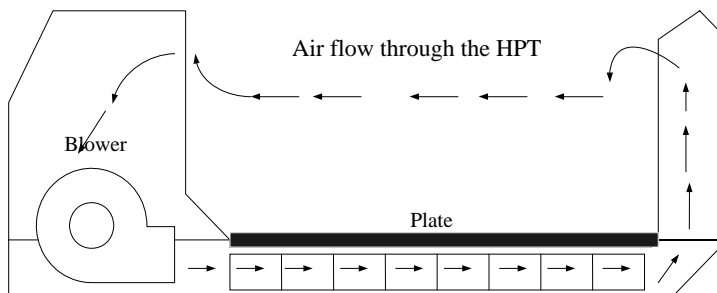
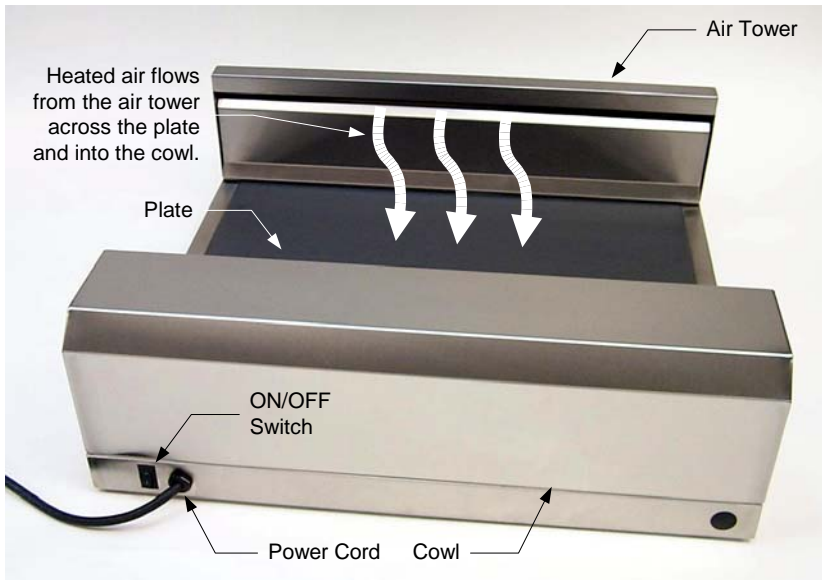

HEATED PASS THROUGH SERVICE AND PARTS

5. Service Procedures

5.1 Adjusting the Temperature

- A. Disconnect the unit from the electrical power source. **This is imperative. Line voltage is accessible on the controller board with the unit connected to the power source.**
- B. A potentiometer regulates the heat produced by the air heater. It is mounted on the HPT's controller board and is accessible through a slot in the left side of the cowl assembly (see Figure 1 below). **NOTE:** The filter screen must first be removed.

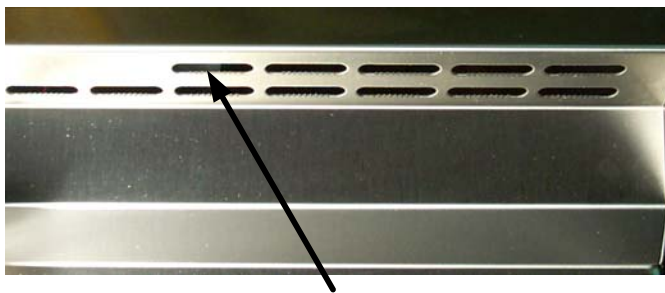

Figure 1: The potentiometer is accessible through the vent in the cowl assembly indicated by the arrow.

- C. Use a long, narrow-blade screwdriver to turn the potentiometer clockwise to increase the temperature; turn it counterclockwise to lower the temperature.

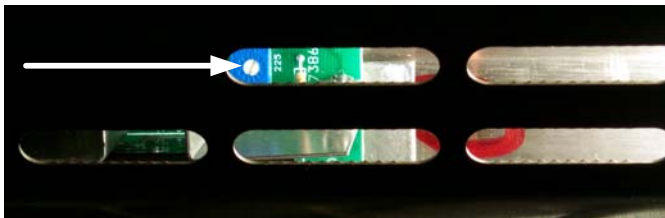

Figure 2: The potentiometer, indicated by the arrow, is adjusted using a narrow-blade screwdriver.

- D. Reconnect the HPT to the power source and check temperature.

5.2 Replacing the Temperature Probe or High Limit Thermostat

- A. Disconnect the unit from the electrical power source.
- B. Turn the unit on its side. Remove the five screws from the chassis bottom.
- C. Set the unit down on its base.
- D. Carefully lift the cowl assembly upward until it is clear of the blower assembly. Lay it on the table behind unit.
- E. The air tower has two sections – a removable front section and the fixed rear section. The front section must be removed to access the temperature probe and high limit thermostat. A pair of slotted brackets, one at each end, holds the front section in place. Insert a $\frac{5}{16}$ -inch nut driver through the air outlet opening and turn the nuts on the outside studs counterclockwise to loosen them. **Do not remove the nuts.**

HEATED PASS THROUGH SERVICE AND PARTS

- F. Grasp the bottom flange of the tower and push upward while rotating the bottom outward to disengage the two slotted brackets on the front section from the studs on the rear section.
- G. Cut the leads of the failed component near the component.
- H. If replacing the temperature probe, unplug the probe connector from the controller board. Leave the leads in place for now.
- I. Remove the failed component from its mounting and install the replacement component in its place.
- J. Securely connect the leads from the new component to the old leads cut in Step G *on the air tower side of the unit*. Grasp the old leads at the opposite end and gently pull them through the unit. **NOTE:** It is easier to pull one lead through at a time.

If the leads become disconnected while pulling them through, it will be necessary to remove the plate. Refer to Steps G through J in procedure 5.3 below.
- K. Once the new wires have been pulled through, replace the terminals cut off in Step J.
- L. If replacing the temperature probe, use a pin pusher to disconnect the old leads from the plug and connect the new wires. Reconnect the plug to the controller board.
- M. If replacing the high limit, connect the leads as shown in the wiring diagram (polarity does not matter).
- N. Reassemble the unit by reversing Steps A through F.

5.3 Replacing the Air Heater

- A. Disconnect the unit from the electrical power source.
- B. Turn the unit on its side. Remove the five screws from the chassis bottom.
- C. Set the unit down on its base.
- D. Carefully lift the cowl assembly upward until it is clear of the blower assembly. Lay it on the table behind unit.
- E. The air tower has two sections – a removable front section and the fixed rear section. The front section must be removed to access the temperature probe. A pair of slotted brackets, one at each end, holds the front section in place. Insert a $\frac{5}{16}$ -inch nut driver through the air outlet opening and turn the nuts on the outside studs counterclockwise to loosen them. ***Do not remove the nuts.***
- F. Grasp the bottom flange of the tower and push upward while rotating the bottom outward to disengage the two slotted brackets on the front section from the studs on the rear section.
- G. Disconnect the plate ground wire from the push-on terminal on the back wall of the air tower.
- H. Using a thin, sharp knife inserted between the plate and the HPT chassis, carefully cut the silicon adhesive between the plate and the sides of the chassis.
- I. Pry up one end of the plate, lifting it away from the chassis. **NOTE:** The plate is held in place by acrylic tape and it will be difficult to break the bond between the plate and the chassis.
- J. Remove the acrylic tape from the frame to prevent rebounding while servicing the unit.
- K. Remove the three screws in the air heater shield and remove the shield to expose the heater.

HEATED PASS THROUGH SERVICE AND PARTS

- L. Disconnect the air heater leads from terminal J2 on the controller board and from the solid state relay (see Wiring Diagram on Page 7), and lift the heater from its bracket.
- M. Install the replacement heater and connect the leads to terminal J2 on the controller board and to the lower left terminal of the solid state relay.
- N. Apply new acrylic tape to the HPT chassis. Stand the plate on its edge against the blower side of the unit.
- O. Once the plate is properly aligned with the chassis, gently lower it into place.
- P. Reconnect the plate ground wire to the push-on terminal on the back wall of the air tower.
- Q. Inspect the gaskets on the bottom of the cowl assembly and air tower assembly for damage. If necessary, remove the old gasket material, clean the surfaces thoroughly, and apply new gaskets.
- R. Slip the slotted brackets on the front section of the air tower assembly up and under the nuts on the tower mounting screws. Push inward and down to ensure that the front section is properly seated.
- S. Check for gaps in the seal between the front section of the air tower assembly and the plate. If a gap is present, remove the front section and apply a second gasket over the one already in place and reseal the front section.
- T. Once the front section is properly positioned and seated, tighten the nuts on the mounting studs to pull it flush against the back of the tower assembly.
- U. Carefully lower the cowl into position and check for a proper seal between the cowl and the plate. Install another gasket over the one already in place if there are gaps between the base of the cowl and the plate.
- V. Carefully turn the unit on its side and reinstall the five screws removed in Step B.
- W. After the cowl is in place, reseal around the edges of the plate with RTV #108 silicone rubber compound, P/N 811-0511.

5.4 Replacing the Blower Assembly

- A. Disconnect the unit from the electrical power source.
- B. Remove the cowl, front section of the air tower, and the plate from the unit per Steps B through J in procedure 5.3 above.
- C. Remove the four $\frac{5}{16}$ -inch nuts that hold the blower bridge in place and remove the bridge from the unit.
- D. Remove the four $\frac{5}{16}$ -inch nuts securing the blower assembly to the chassis. **NOTE:** A magnetized nut driver makes this task much easier.
- E. Lay a piece of cardboard on the plate to prevent scratching it. Lift the blower assembly out of the unit and set it on the plate.
- F. Cut the wire ties on the wiring bundle and, one at a time, disconnect the wires from the failed assembly and connect the corresponding wire from the replacement motor.
- G. Position the replacement motor over the mounting studs and secure it in place with the $\frac{5}{16}$ -inch nuts removed in Step D.
- H. Reinstall the blower bridge and secure it in place with the $\frac{5}{16}$ -inch nuts removed in Step C.
- I. Apply new acrylic tape (P/N 811-1042) to the HPT chassis. Stand the plate on its edge against the blower side of the unit.
- J. Once the plate is properly aligned with the chassis, gently lower it into place.

HEATED PASS THROUGH SERVICE AND PARTS

- K. Reconnect the plate ground wire to the push-on terminal on the back wall of the air tower.
- L. Inspect the gaskets on the bottom of the cowl assembly and air tower assembly for damage. If necessary, remove the old gasket material, clean the surfaces thoroughly, and apply new gaskets.
- M. Slip the slotted brackets on the front section of the air tower assembly up and under the nuts on the tower mounting screws. Push inward and down to ensure that the front section is properly seated.
- N. Check for gaps in the seal between the front section of the air tower assembly and the plate. If a gap is present, remove the front section and apply a second gasket over the one already in place and reseal the front section.
- O. Once the front section is properly positioned and seated, tighten the nuts on the mounting studs to pull it flush against the back of the tower assembly.
- P. Carefully lower the cowl into position and check for a proper seal between the cowl and the plate. Install another gasket over the one already in place if there are gaps between the base of the cowl and the plate.
- Q. Carefully turn the unit on its side and reinstall the five screws removed in Step B.
- R. After the cowl is in place, reseal around the edges of the plate with RTV #108 silicone rubber compound, P/N 811-0511.

5.5 Replacing Other Electronic Components

- A. Disconnect the unit from the electrical power source.
- B. Turn the unit on its side. Remove the five screws from the chassis bottom.
- C. Set the unit down on its base.
- D. Carefully lift the cowl assembly upward until it is clear of the blower assembly. Lay it on the table behind unit.
- E. If replacing any component other than the ON/OFF switch, hold the replacement component next to the component to be replaced, disconnect the wires from the failed component and connect them to the new component. When all connections have been made, remove the failed component from its mounting and install the replacement component.
- F. If replacing the ON/OFF switch, disconnect the wiring and push the switch out of the chassis. Press the replacement switch into the chassis and reconnect the wiring in accordance with the wiring diagram.

HEATED PASS THROUGH SERVICE AND PARTS

6. Wiring Diagram

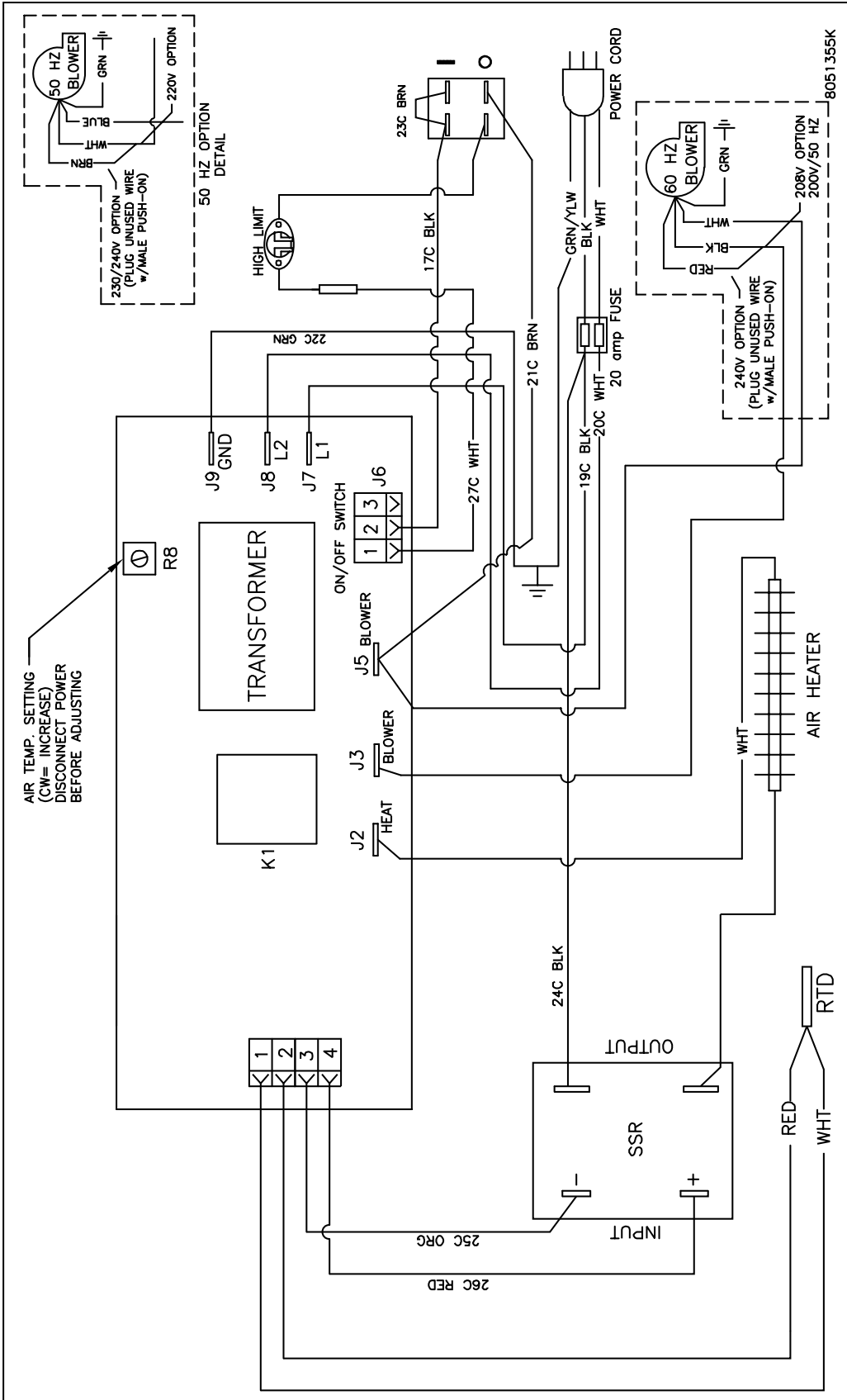

HEATED PASS THROUGH SERVICE AND PARTS

7 Common Repair Parts List

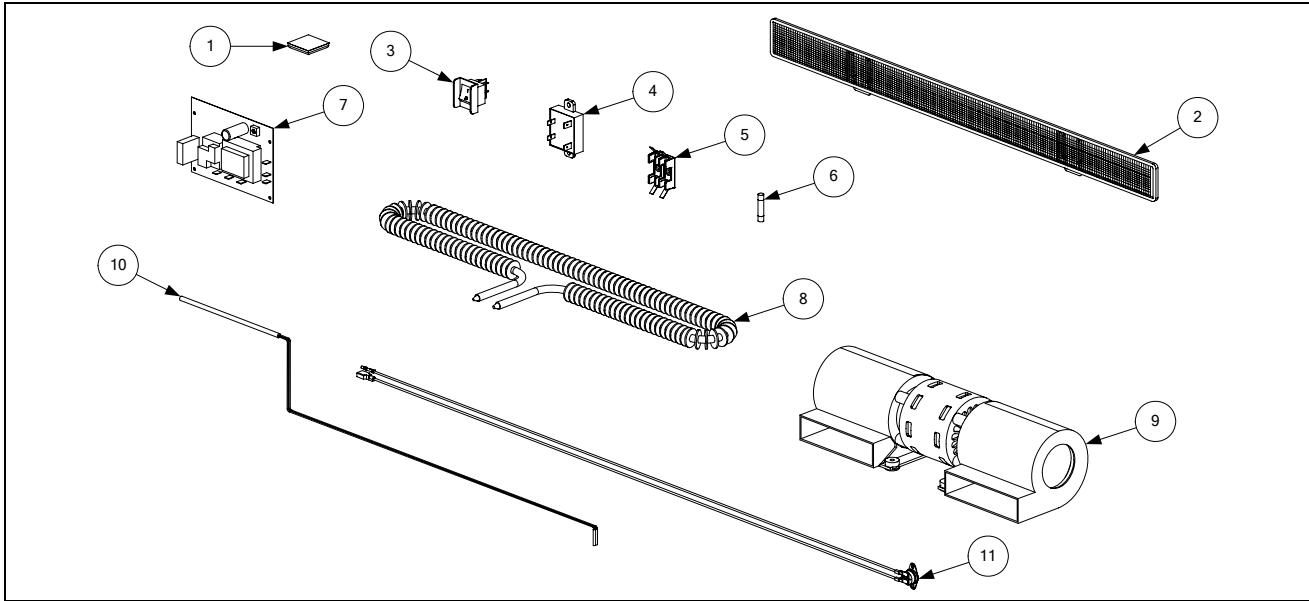

| ITEM | PART # | COMPONENT |
|------|----------|--|
| 1 | 826-1561 | Pad, Leg (pkg of 4) |
| 2 | 810-1724 | Screen, HPT Filter |
| 3 | 807-3308 | Switch, Black ON/OFF Rocker |
| 4 | 807-4057 | Relay, 50-Amp, Solid State |
| 5 | 807-2820 | Block, .25 X 1.25 2-pole Fuse |
| 6 | 807-2819 | Fuse, 3ab-314, 20-Amp |
| 7 | 106-2790 | Board, HPT Controller |
| 8 | 826-1549 | Kit, 208V Heater Replacement (includes heater and acrylic tape) |
| * | 826-1550 | Kit, 240V Heater Replacement (includes heater and acrylic tape) |
| 9 | 826-1551 | Kit, 208/240V Blower Replacement (includes blower and acrylic tape) |
| 10 | 807-3036 | Probe, HPT Temperature |
| 11 | 826-1959 | Kit, HPT High-Limit Replacement (includes high-limit and acrylic tape) |
| * | 810-2226 | Plate, 22" HPT |
| * | 816-0418 | Gasket, Cowl and Air Tower (one 2-foot gasket) |
| * | 811-0511 | Rubber, RTV #108 Silicone |
| * | 811-1042 | Tape, 1/2-inch Acrylic 1-Sided (36-yard roll) |

* Not illustrated.



Shipping Address: 8700 Line Avenue, Shreveport, Louisiana 71106

TEL 1-318-865-1711 FAX (Parts) 1-318-219-7140 FAX (Tech Support) 1-318-219-7135

PRINTED IN THE UNITED STATES

SERVICE HOTLINE
1-800-551-8633

Price: \$6.00
819-5931
July 2011