



**Models SCF/SCFC 1824G, 2424G and 1824/2424G  
Systems with Built-In Filtration**

**24G Series Flatbottom  
Gas Fryers  
Service & Parts Manual**



NON-CE

&



Frymaster Dean, a member of the Commercial Food Equipment Service Association, recommends using CFESA Certified Technicians.

PRINTED IN THE USA

**24-Hour Service Hotline  
1-800-551-8633**

SEPT 2011

\* 8196031 \*

[service@frymaster.com](mailto:service@frymaster.com)

[www.frymaster.com](http://www.frymaster.com)

**Please read all sections of this manual and retain for future reference.**

This product has been certified as commercial cooking equipment and **MUST** be installed by professional personnel as specified. Installation, maintenance and repairs should be performed by your **FRYMASTER DEAN FACTORY AUTHORIZED SERVICER**.

 **DANGER**

Do not store or use gasoline or other flammable vapors and liquids in the vicinity of this or any other cooking appliance.

 **DANGER**

Instructions explaining procedures to be followed **MUST** be posted in a prominent location in the event the operator detects a gas leak. This information can be obtained from the local gas company or gas supplier.

 **WARNING**

Improper installation, adjustment, alteration, service or maintenance can cause property damage, injury or death. Read the installation, operating and maintenance instructions thoroughly before installing or servicing this equipment.

 **DANGER**

Safe and satisfactory operation of your equipment depends on proper installation. Installation **MUST** conform with local codes, or in absence of local codes, with the National Fuel Gas Code, ANSI Z223.1; The Natural Gas Installation Code, CAN/CGA-B149.1; The Propane Installation Code, CAN/CGA-B149.2; or The latest edition of the National Electric Code, N.F.P.A. 70.

**NOTICE**

**IF, DURING THE WARRANTY PERIOD, THE CUSTOMER USES A PART FOR THIS MANITOWOC FOOD SERVICE EQUIPMENT OTHER THAN AN UNMODIFIED NEW OR RECYCLED PART PURCHASED DIRECTLY FROM FRYMASTER DEAN, OR ANY OF ITS AUTHORIZED SERVICE CENTERS, AND/OR THE PART BEING USED IS MODIFIED FROM ITS ORIGINAL CONFIGURATION, THIS WARRANTY WILL BE VOID. FURTHER, FRYMASTER DEAN AND ITS AFFILIATES WILL NOT BE LIABLE FOR ANY CLAIMS, DAMAGES OR EXPENSES INCURRED BY THE CUSTOMER WHICH ARISE DIRECTLY OR INDIRECTLY, IN WHOLE OR IN PART, DUE TO THE INSTALLATION OF ANY MODIFIED PART AND/OR PART RECEIVED FROM AN UNAUTHORIZED SERVICE CENTER.**

 **DANGER**

The crumb tray in fryers equipped with a filter system must be emptied into a fireproof container at the end of frying operations each day. Some food particles can spontaneously combust if left soaking in certain shortening material. Additional information can be obtained in the filtration manual included with the system.

 **DANGER**

The front ledge of the fryer is not a step. Do not stand on the fryer. Serious injury can result from slips or contact with the hot oil.

 **WARNING**

Drawings and photos used in this manual are intended to illustrate operational, cleaning and technical procedures and may not conform to on-site management operational procedures.

 **WARNING**

No structural material on the fryer should be altered or removed to accommodate placement of the fryer under a hood. Questions? Call the Frymaster Dean Service Hotline at 1-800-551-8633.

This equipment is to be installed in compliance with the basic plumbing code of The Building Officials and Code Administrators International, Inc. (BOCA) and the Food Service Sanitation Manual of the Food and Drug Administration.

**COMPUTERS (WHERE APPLICABLE)**

**FCC**

This device complies with Part 15 of the FCC rules. Operation is subject to the following two conditions: 1) This device may not cause harmful interference, and 2) This device must accept any interference received, including interference that may cause undesired operation. While this device is a verified Class A device, it has been shown to meet the Class B limits.

**CANADA**

This digital apparatus does not exceed the Class A or B limits for radio noise emissions as set out by the ICES-003 standard of the Canadian Department of Communications.

Cet appareil numerique n'emet pas de bruits radioelectriques depassany les limites de classe A et B prescrites dans la norme NMB-003 edictee par le Ministre des Communcations du Canada.

 **DANGER**

**THIS PRODUCT CONTAINS CHEMICALS KNOWN TO THE STATE OF CALIFORNIA TO CAUSE CANCER AND/OR BIRTH DEFECTS OR OTHER REPRODUCTIVE HARM.**

Operation, installation, and servicing of this product could expose you to airborne particles of glasswool or ceramic fibers, crystalline silica, and/or carbon monoxide. Inhalation of airborne particles of glasswool or ceramic fibers is known to the State of California to cause cancer. Inhalation of carbon monoxide is known to the State of California to cause birth defects or other reproductive harm.

 **WARNING**

Do not bang fry baskets or other utensils on the fryer's joiner strip. The strip is present to seal the joint between the fry vessels. Banging fry baskets on the strip to dislodge shortening will distort the strip, adversely affecting its fit. It is designed for a tight fit and should only be removed for cleaning.

# 24G Series Flatbottom Gas Fryers

## Service & Parts Manual

### TABLE OF CONTENTS

		PAGE #
<b>1.</b>	<b>SERVICE PROCEDURES</b> .....	1-1
1.1	Functional Description.....	1-1
1.2	Accessing Fryers for Servicing.....	1-5
1.3	Cleaning Gas Valve Vent Tube.....	1-6
1.4	Adjusting Burner Manifold Gas Pressure.....	1-6
1.5	Adjusting Pilot Flame.....	1-7
1.6	Calibrating the Thermatron Temperature Controller.....	1-7
1.7	Replacing Fryer Components.....	1-9
1.7.1	Remove/Replace Temperature Probe or High-Limit Thermostat.....	1-9
1.7.2	Removing /Replacing Rocker Switches.....	1-11
1.7.3	Replacing the Gas Valve.....	1-12
1.7.4	Replacing the Pilot Assembly or Direct Spark Ignitor.....	1-12
1.7.5	Removing/Replacing Blower Assembly or Air Prover Switch.....	1-13
1.7.6	Replacing the Frypot.....	1-15
<b>1.8</b>	<b>Troubleshooting and Problem Isolation</b> .....	<b>1-19</b>
1.8.1	Ignition Failures.....	1-20
1.8.2	Improper Burner Functioning.....	1-21
1.8.3	Improper Temperature Control.....	1-23
1.8.4	Filtration Problems.....	1-23
1.8.5	Leakage.....	1-25
<b>1.9</b>	<b>Troubleshooting Guides</b> .....	<b>1-26</b>
1.9.1	Pilot Burner Malfunctions.....	1-26
1.9.2	Main Burner Malfunctions.....	1-27
1.9.3	Indicator Lights.....	1-28
<b>1.10</b>	<b>Wiring Diagrams</b> .....	<b>1-29</b>
1.10.1	24G Series Single Fryers, Non-CE without Boil-Out Switch.....	1-29
1.10.2	24G Series Single Fryers, Non-CE with Boil-Out Switch.....	1-30
1.10.3	24GTI with Drain Safety Switch, and Boil-Out Option Enabled – LJS.....	1-31
1.10.4	24GTI with Drain Safety Switch, and Boil-Out Option Enabled – 120V non-LJS.....	1-32
1.10.5	24GTI with Drain Safety Switch, and Boil-Out Option Enabled – 250V non-LJS.....	1-33
1.10.6	24GTI with Drain Safety Switch, and Boil-Out Option Disabled – KFC.....	1-34
1.10.7	24GTI with Drain Safety Switch, and Boil-Out Option Disabled – non-KFC.....	1-35
1.10.8	24G Series Single Fryers, CE Approved.....	1-36
1.10.9	Wiring, Standing Pilot - SCFC Models prior to May 2011.....	1-37
1.10.10	Wiring, Standing Pilot - SCFC Models after May 2011.....	1-38
1.10.11	24GTI Oil Return/Filter System.....	1-39

# 24G Series Flatbottom Gas Fryers

## Service & Parts Manual

### TABLE OF CONTENTS (cont.)

		PAGE #
<b>2.</b>	<b>PARTS LIST</b> .....	2-1
<b>2.1</b>	<b>Blower Assembly and Combustion Air</b> .....	2-1
<b>2.2</b>	<b>Burner Manifold and Related Components</b> .....	2-2
<b>2.3</b>	<b>Flue Caps, Top Caps, and Related Components</b> .....	2-4
<b>2.4</b>	<b>Common Cabinet Components (<u>SCFC</u> Models)</b> .....	2-6
2.4.1	Cabinetry.....	2-6
2.4.2	Door Assemblies and Component Parts.....	2-8
2.4.3	Control Panels, Wireways, and Related Components.....	2-9
2.4.4	Oil Return and Suction Manifolds.....	2-11
2.4.5	Filter Unit.....	2-13
2.4.6	Frypot, Drain, and Oil Return Components.....	2-14
<b>2.5</b>	<b>Previous Style (<u>SCF</u> Models)</b> .....	2-16
2.5.1	Cabinetry.....	2-16
2.5.2	Door Assemblies and Component Parts.....	2-18
2.5.3	Control Panels, Wireways, and Related Components.....	2-19
2.5.4	Oil Return and Suction Manifolds.....	2-21
2.5.5	Filter Unit.....	2-24
2.5.6	Frypot, Drain, and Oil Return Components.....	2-25
<b>2.6</b>	<b>Drain Valve and Components</b> .....	2-27
<b>2.7</b>	<b>Wiring Connectors, Pin Terminals, and Power Cords</b> .....	2-28
<b>2.8</b>	<b>Screws, Nuts, and Fasteners</b> .....	2-29
	<b>APPENDIX: ND90 Built-in Filter System</b> .....	2-30

# 24G SERIES FLATBOTTOM GAS FRYERS

## CHAPTER 1: SERVICE PROCEDURES

---

### 1.1 Functional Description

24G Series Flatbottom gas fryers contain a welded steel frypot (mild steel) with heat-transfer ducting on the frypot bottom for efficient heating of oil without scorching. A draft inducer draws air over the burners for combustion. Air movement directs the combustion products back and forth across the frypot bottom by means of a set of baffles, transferring the heat evenly. Cold air is prevented from entering the combustion chamber and cooling the oil during the coasting cycle.

Flames originate from orifices in three tubular burners positioned beneath the frypot. The diameter of the orifices differs for Natural (CE:G20/G25) and LP (CE:G31) gas as indicated in the table below.

<b>NON-CE (Altitudes of 2000 feet or less)</b>							
MODEL	INPUT (BTU)	GAS TYPE	ORIFICE [DRILL SIZE (MM)]	ORIFICE PART #	QTY	EQUIPMENT PRESSURE	
						MBAR	INCH W.C.
1824/2424G	120	NAT	#34 (2.82)	810-2051	3	10	4
		LP	#50 (1.78)	810-2317	3	27.5	11
<b>CE ONLY (Altitudes of 2000 feet or less)</b>							
MODEL	INPUT (kW)	GAS TYPE	ORIFICE (MM)	ORIFICE PART #	QTY	EQUIPMENT PRESSURE	
						MBAR	INCH W.C.
1824/2424G	30,0 (88,000 BTU)	G20	2,50	810-2628	3	14,5	5,8
		G25	2,50	810-2628	3	21,0	8,4
		G31	1,60	810-2317	3	31,0	12,44

An electromechanical gas valve regulates gas flow to the manifold. 24G Series Flatbottom gas fryers are equipped with either a 120-volt valve system (standing pilot) or a 24-volt valve system (electronic ignition or CE standing pilot). Units may be configured with either a pilot ignition system (standing pilot) or an electronic ignition system (direct spark ignition).

# 24G SERIES FLATBOTTOM GAS FRYERS

## CHAPTER 1: SERVICE PROCEDURES

### Pilot System Configuration

The pilot system is the pilot orifice, pilot hood, and a thermocouple. The pilot serves two purposes. The first is to light the burner, the second is to heat the thermocouple. In operation, the thermocouple is in contact with the pilot flame and generates millivolts. The millivolt output energizes the gas valve pilot coil, which in turn opens the pilot valve. If the pilot flame is extinguished, voltage is lost to the gas valve pilot coil and the pilot valve closes. The gas valve is constructed so that the main valve will not open if the pilot valve is not open. The pilot flame must be manually lit when the fryer is first placed into operation. A separate circuit, activated by the fryer ON/OFF switch, provides voltage through the Thermatron temperature controller to the gas valve main coil, which opens the main valve.

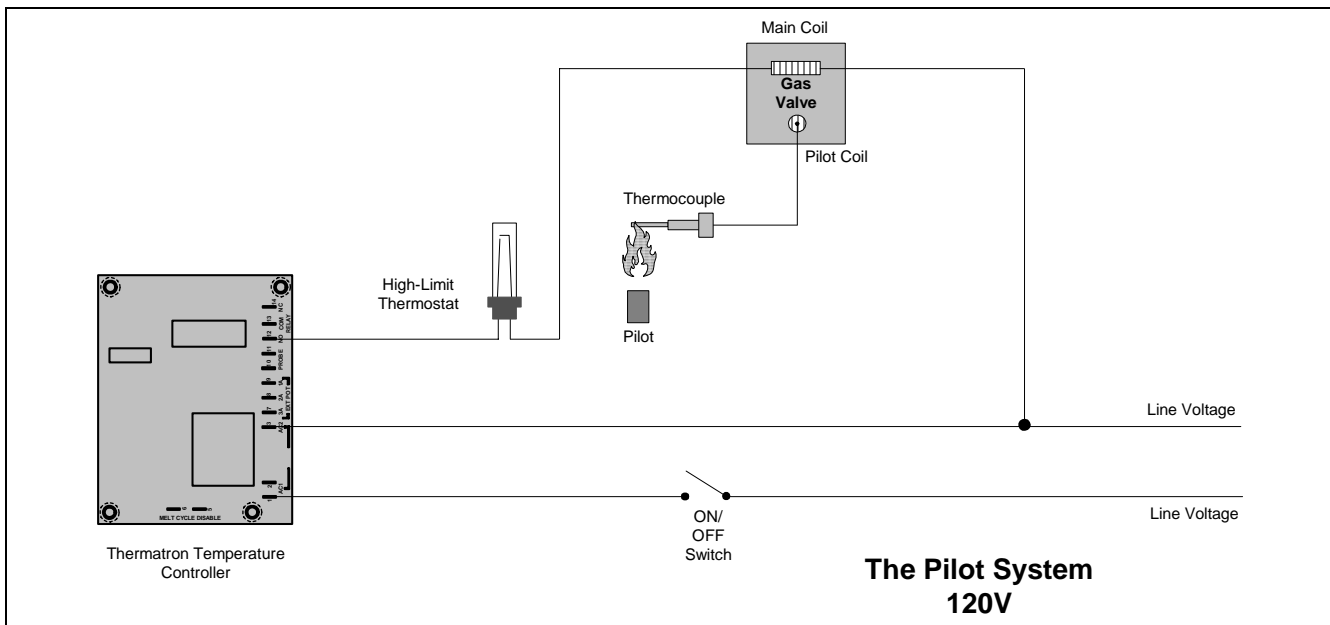

### Electronic Ignition Configuration

In units configured for electronic ignition, an ignition module connected to an ignitor assembly replaces the pilot system. The ignition module performs three important functions: it provides an ignition spark, supplies voltage to the gas valve, and proofs the burner flame.

The module contains a time delay circuit and a coil that activates the gas valve. The ignitor assembly consists of a spark plug and a flame sensor element.

At start-up the ON/OFF switch is placed in the "ON" position, supplying 115 VAC or 230 VAC, according to system configuration, to the Thermatron interface board. The voltage is stepped down via transformer to 24 VAC before entering the ignition module. If resistance in the temperature probe indicates the temperature in the frypot is below 150°F (66°C), the current flows through a melt

## 24G SERIES FLATBOTTOM GAS FRYERS

### CHAPTER 1: SERVICE PROCEDURES

---

cycle circuit where a switch alternately closes for approximately 4 seconds and opens for approximately 20 seconds. If the temperature is 150°F (66°C) or above, the current flows through a heat circuit, bypassing the timer switch. In either case, current is supplied to the other leg of the heat relay coil, which then closes an electronic switch in the 24 VAC circuit to provide current to the ignition module.

Circuitry in the ignition module sends 24 VAC current to the gas valve via a normally closed high-limit switch and a drain safety switch. Simultaneously, the module causes the ignitor to spark for up to 11 seconds to light the burner flame. A flame sensor verifies that the burner is lit by measuring the flow of microamps through the flame. If the burner does not light (or is extinguished), current to the ignition module is interrupted, preventing the main valve from opening, and the ignition module "locks out" until the power switch is turned "OFF", then back "ON".

A temperature probe monitors the temperature in the frypot. When the programmed setpoint temperature is reached, resistance in the probe causes the heat cycle circuitry in the controller to interrupt current flow through the heat relay. This in turn interrupts the 24 VAC to the ignition module, resulting in closure of the gas valve.

### Control Options

24G Series Flatbottom gas fryers are equipped with Thermatron temperature controller. The fryer is turned on and off by means of a rocker switch and the temperature is set by adjusting a potentiometer. The Thermatron board is located in the wireway box behind the control panel, or in a component box inside the cabinet (depending on fryer configuration).

The Thermatron temperature controller operates by comparing resistance between the potentiometer setting and the temperature probe. If the resistance values don't match, an on-board relay energizes, sending voltage to the gas valve that supplies fuel to the burners. When the resistance values are equal, the on-board relay de-energizes, interrupting voltage to the gas valve, which stops the fuel flow.

Depending on the system configuration and destination, 24VAC, 115VAC or 208/230VAC controller boards are used.



## 24G SERIES FLATBOTTOM GAS FRYERS CHAPTER 1: SERVICE PROCEDURES

---

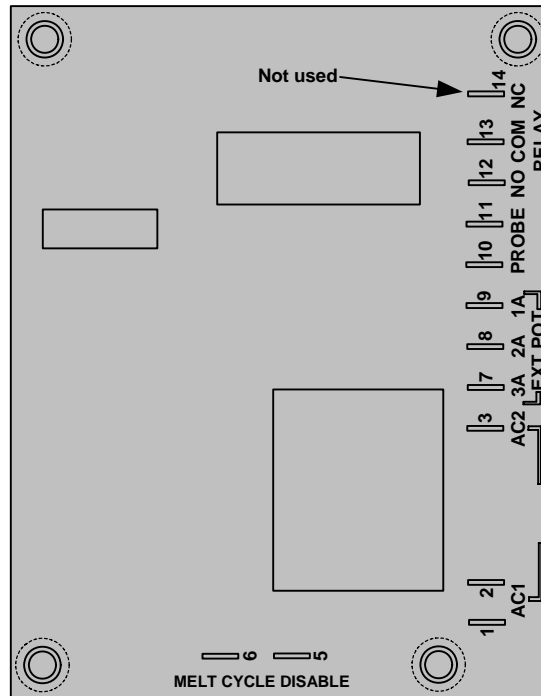

**Thermatron Controller Board**

Line voltage enters the interface board at terminals 1 and 3. The temperature controls (potentiometer) are connected to terminals 7, 8 and 9. The sensor probe circuit is connected to terminals 10 and 11. The high-limit and gas valve routes through terminal 12. Terminals 2 and 13 are jumped out. Terminals 5 and 6 are the melt-cycle disable circuit. The melt cycle is enabled unless terminals 5 and 6 are jumped out.

## 24G SERIES FLATBOTTOM GAS FRYERS

### CHAPTER 1: SERVICE PROCEDURES

---

#### Safety Components

All 24G Series Flatbottom gas fryers are equipped with a *high-limit thermostat*. In the event that the fryer fails to properly control the oil temperature, the high-limit thermostat prevents the fryer from overheating to flash point. The high-limit thermostat acts as a normally closed power switch that opens when exposed to temperatures above 410°F [(210°C)- CE] to 435°F [(224°C)- Non-CE]. CE and non-CE high-limits are not interchangeable.

Frying systems with built-in filtration are equipped with drain microswitches that disable the fryer if the drain valves are not completely closed. Opening a drain valve (i.e. filtering or draining the fryer) automatically opens the reset switch circuit. The drain valve must be fully closed prior to resetting the safety switch.

#### 1.2 Accessing Fryers for Servicing



**Moving a fryer filled with cooking oil/shortening may cause spilling or splattering of the hot liquid. Follow the draining instructions included with the fryer before attempting to relocate a fryer for servicing.**

**NOTE:** Perform the following only if the fryer cannot be serviced in its installed location. Some of the following service procedures require the fryer to be connected to the gas and/or electrical supply.

1. Shut off the gas supply to the unit. Unplug the power cords. Remove any attached restraining devices.
2. Disconnect the unit from the gas supply.
3. Relocate the fryer for service accessibility.
4. After servicing is complete, reconnect the unit to the gas supply, reattach restraining devices, and plug in the electrical cords.

## 24G SERIES FLATBOTTOM GAS FRYERS

### CHAPTER 1: SERVICE PROCEDURES

---

#### 1.3 Cleaning the Gas Valve Vent Tube (if applicable)

1. Set the fryer power switch and the gas valve to the "OFF" position.
2. Carefully unscrew the vent tube from the gas valve. **NOTE:** The vent tube may be straightened for ease in removal.
3. Pass a piece of wire through the tube to remove any obstruction. Remove the wire and blow through the tube to ensure it is clear.
4. Reinstall tube and bend so that the opening is pointing downward.

#### 1.4 Adjusting Burner Manifold Gas Pressure

**⚠ WARNING**

**This task should be performed by qualified service personnel only.**

1. Ensure that the gas valve knob is in the "OFF" position.
2. Remove the pressure tap plug from the burner manifold.
3. Insert the fitting for a gas pressure-measuring device into the pressure tap hole.

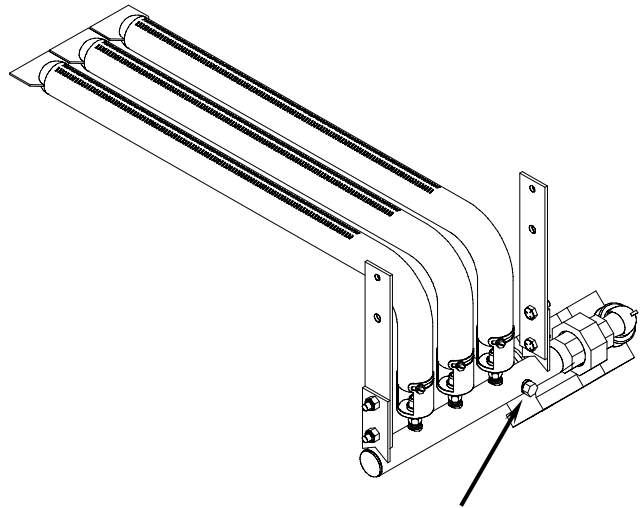

Remove pressure tap from burner manifold to check burner manifold pressure.

4. Place the gas valve in the "ON" position then place the fryer power switch in the "ON" position. When the burner lights and continues to burn, note gas pressure reading for correct pressure in accordance with the table on page 1-1.

## 24G SERIES FLATBOTTOM GAS FRYERS

### CHAPTER 1: SERVICE PROCEDURES

---

5. To adjust burner gas pressure, remove the cap from the gas valve regulator and adjust to correct pressure (arrows).

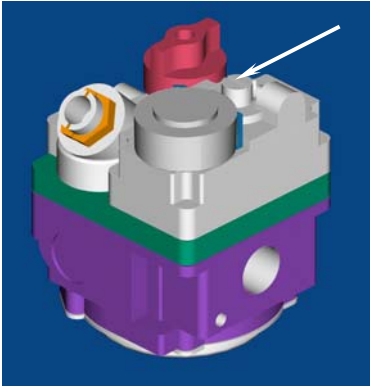

Pilot Ignition Valve (Line Voltage)

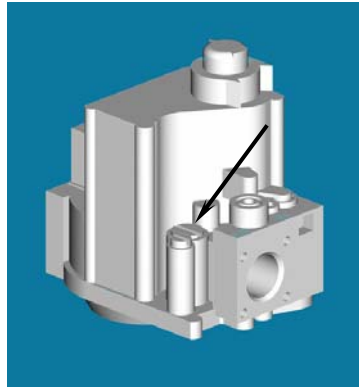

Non-CE Electronic Ignition Valve

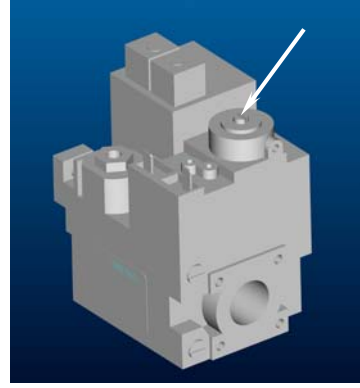

CE Pilot Ignition Valve

6. Place the fryer power switch and the gas valve in the "OFF" position. Remove the pressure-measuring device fitting from the pressure tap hole and reinstall the pressure tap plug.

### 1.5 Adjusting the Pilot Flame (where applicable)

1. Remove the cap from the pilot adjustment screw hole on the gas valve.
2. Using a small, flat-tipped screwdriver, turn the pilot adjusting screw counterclockwise to increase length of flame or clockwise to decrease length of flame. Adjust to obtain a flame from 1 to 1-½ inches long.
3. Reinstall the pilot adjustment screw cap.

### 1.6 Calibrating the Thermatron Temperature Controller

1. Fill the frypot to the proper oil-level line with cooking oil/shortening. If solid shortening is used, ensure that the shortening is properly packed and melted in the frypot before proceeding.
2. Ensure the fryer ON/OFF switch is in the "OFF" position, and then light the pilot.
3. Place the fryer ON/OFF switch in the "ON" position. Set the Thermatron dial to 325°F (162°C).
4. Allow the oil/shortening to stabilize at setpoint temperature. This is evident when the burners have cycled on and off several times.

## 24G SERIES FLATBOTTOM GAS FRYERS

### CHAPTER 1: SERVICE PROCEDURES

---

5. Insert a thermometer or pyrometer into the frypot within 3 inches of the probe bulb. Ensure the tip of the thermometer/pyrometer does not touch the bottom or sides of the frypot.
6. If the temperature on the thermometer is higher or lower than 325°F (162°C), the dial is out of calibration.
7. Calibrate the dial by first loosening two setscrews in the dial (arrows). After loosening both setscrews, slowly turn the dial to match the temperature reading of the thermometer. Tighten each setscrew, ensuring the dial does not move on the shaft during tightening.
8. Allow burners to cycle on and off several times, then recheck oil temperature as described in step #5. If the Thermatron dial temperature matches the thermometer temperature, the controller is calibrated. If not, repeat step #7.
9. After calibration is complete, place the fryer power switch in the "OFF" position and disconnect the fryer from the electrical supply.

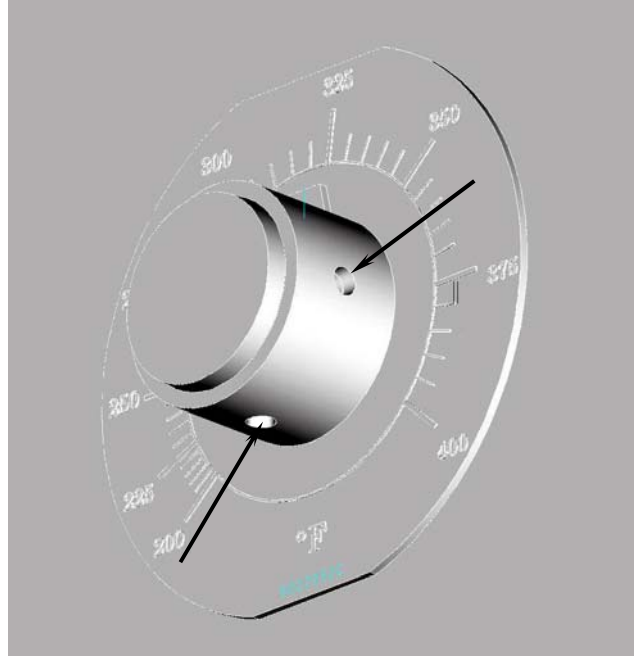

Loosen two setscrews in dial (arrows) to recalibrate controller.

# 24G SERIES FLATBOTTOM GAS FRYERS

## CHAPTER 1: SERVICE PROCEDURES

---

### 1.7 Replacing Fryer Components

#### 1.7.1 Remove/Replace Temperature Probe or High-Limit Thermostat

1. Disconnect the fryer from the electrical supply.
2. Allow the frypot to cool for 10 minutes before draining. Drain cooking oil/shortening from the frypot. Allow the frypot to cool completely before proceeding.
3. Remove the fryer door(s) for access to control panel screws. Lift door up, disengage rod from lower door bracket, and then remove door. (Current production models have spring-loaded door pins. Disengage bottom pin from the hinge, and then remove door.)
4. Remove the marine edge (where applicable) from the topcap.

5. Support the control panel and remove screws securing the panel to the wireway box. Remove the control panel.

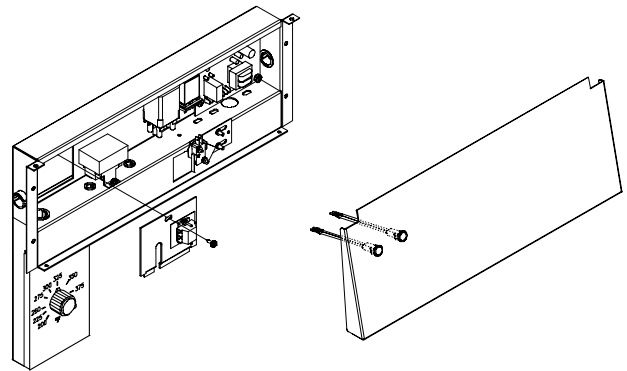

6. On units with switches/indicator lights on the control panel, mark and unplug the wiring, and then remove the control panel.

7. Remove screw securing probe/high-limit access cover to wireway box. Remove access cover and set aside.

**Note:** Some systems have a wiring terminal block mounted on the access cover. Mark and disconnect the wiring to the terminal block before removing access cover.



## 24G SERIES FLATBOTTOM GAS FRYERS CHAPTER 1: SERVICE PROCEDURES

---

8. Remove the sensor bulb guard to access the probe and high-limit. Current production systems have a sensor bulb clamp that must be removed prior to removing the probe or high-limit from the frypot.



9. On the sensor bulb being removed, loosen and unscrew completely the compression nut, then the pass-through nut from the frypot. Carefully remove the sensor bulb from the frypot, being careful not to damage the remaining sensor bulb.



Temperature probe.

High-limit.

10. If removing the high-limit, remove the screws securing it to the wireway box. Mark and remove the wiring from the high-limit housing.

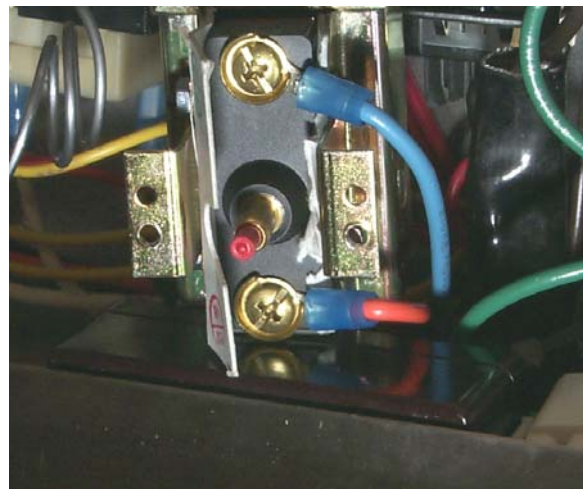

High-limit.

11. Reverse steps to install new temperature probe or high-limit. If reinstalling high-limit, ensure the capillary tube is properly routed around the temperature probe before tightening (see photo, Step #8). Reconnect wiring removed from defective high-limit.

## 24G SERIES FLATBOTTOM GAS FRYERS

### CHAPTER 1: SERVICE PROCEDURES

**IMPORTANT (High-Limit):** When installing new high-limit, ensure the capillary tube and bulb are positioned properly with the mounting hardware installed prior to tightening the compression nut. **Once tightened, the capillary tube cannot be repositioned.**

**IMPORTANT (Temperature Probe):** When installing new temperature probe, ensure probe is positioned properly with the mounting hardware installed (current production systems), or 1/8" from frypot bottom (older systems), prior to tightening the compression nut. **Once tightened, the probe cannot be repositioned.**

In older fryers, ensure probe tip is 1/8" from frypot bottom for proper temperature sensing.

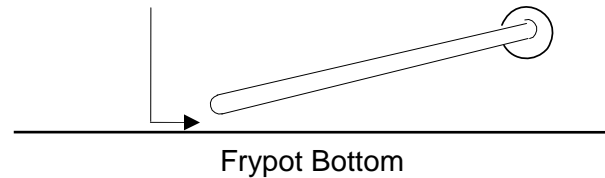

#### 1.7.2 Removing/Replacing Rocker Switches

1. Disconnect the fryer from the electrical supply.
2. If switches are located on front panel or control box, remove the screws securing panel. Do not allow the panel to hang on the switch wiring harness; use some type of support.
3. Depress the retaining clips (see illustration below) and push the switch out of the slot. If there is a switch-guard present, retain it for installation of the replacement switch.

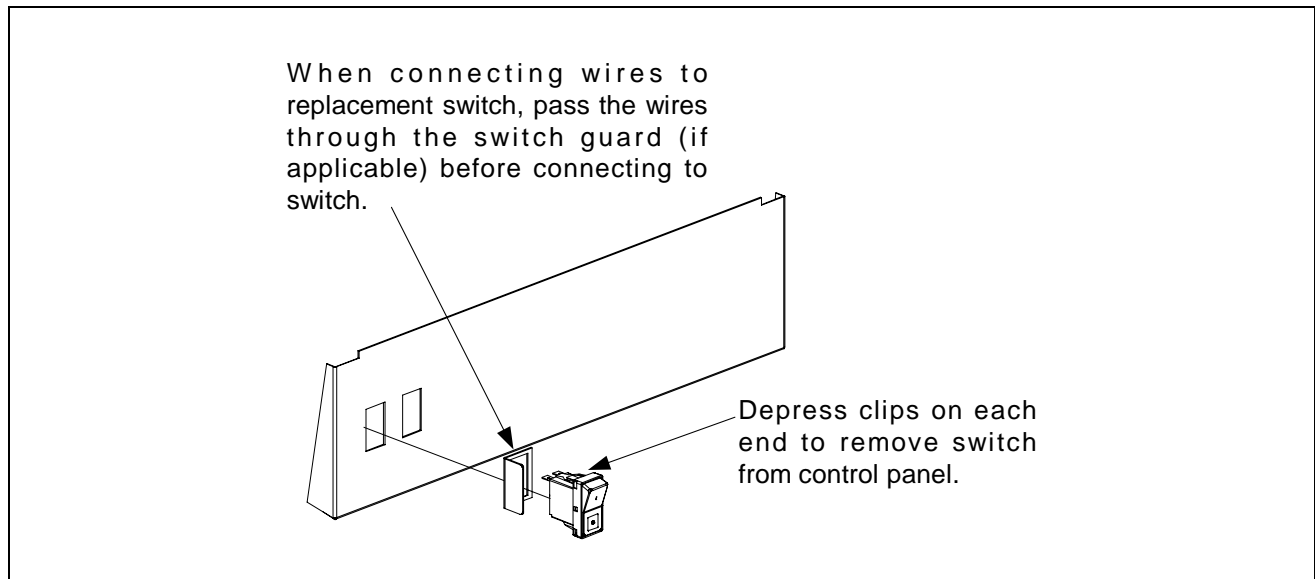

4. Remove wires one at a time from the switch being removed and connect to the replacement switch until all wires are transferred.
5. Reverse the above steps for reassembly.



## 24G SERIES FLATBOTTOM GAS FRYERS

### CHAPTER 1: SERVICE PROCEDURES

---

#### 1.7.3 Replacing the Gas Valve



**Drain the frypot or remove drain valve handle to prevent accidental opening before proceeding further.**

1. Disconnect fryer from electrical and gas supplies.
2. Disconnect the wires from the gas valve terminal block, marking each wire to facilitate reconnections. For 120VAC gas valves, disconnect the black wire from the high-limit, then remove the bombtail connecting the white wire.
3. Remove the high-limit thermostat wire from the gas valve pilot coil (all but 120VAC valves).
4. Remove the pilot gas line fitting from the gas valve.
5. Remove the pipe union collars to the left and right of the gas valve and remove the valve.
6. Remove the pipefitting from the old gas valve and install on the replacement valve, using Loctite PST567 or equivalent pipe thread sealant on threads. Do not apply sealant to the first two pipe threads. Doing so will clog and damage the gas valve.
7. Reverse steps 1-5 to install the replacement gas valve.

#### 1.7.4 Replacing the Pilot Assembly or Direct Spark Ignitor

##### 1.7.4.1 Replacing Pilot Assembly

1. Remove the burner shield from the burner-box slots.
2. Remove the pilot tubing from the bottom of the pilot assembly.
3. Remove the mounting screw from the pilot mounting-bracket and remove the pilot.
4. Reverse the procedure to replace the pilot assembly. Ensure the replacement assembly is properly positioned above the center burner tube before tightening mounting-bracket screw.

**NOTE:** The above procedure is applicable to standing pilot assemblies only.

## 24G SERIES FLATBOTTOM GAS FRYERS

### CHAPTER 1: SERVICE PROCEDURES

#### 1.7.4.2 Replacing Direct-Spark Ignitor Assembly (Units with Electronic Ignition Only)

1. Remove the burner shield from the burner-box slots.
2. Disconnect sense wire and ignition cable from the ignitor.
3. Remove the mounting screw from the ignitor mounting-bracket and remove the ignitor.
4. Reverse the procedure to replace the ignitor assembly. Ensure the ignitor is properly positioned in relation to the center burner before tightening mounting screw.

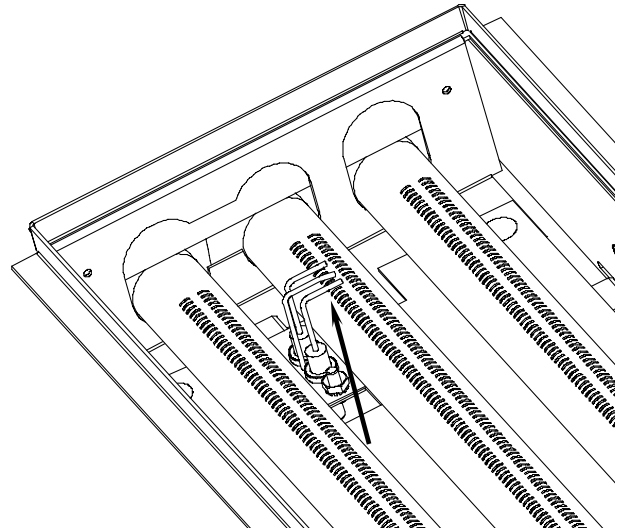

**NOTE:** The above procedure is applicable to fryers equipped with electronic ignition systems only.

Ensure ignitor is properly positioned (arrow) over the center burner prior to tightening the mounting screw.

#### 1.7.5 Removing/Replacing Blower Assembly or Air Prover Switch

1. Remove back panel. On systems with built-in filtration, use care not to damage the oil-return heat-tape wiring insulation when removing backs (multi-battered systems after 02/03 have two-piece back panels; remove both to access blower assembly).



Multi-battered systems after 02/03 have upper and lower back panels, which must be removed to access the blower assembly (fryer above shown with upper back panel removed).

## 24G SERIES FLATBOTTOM GAS FRYERS

### CHAPTER 1: SERVICE PROCEDURES

- Remove blower assembly by removing four screws (two screws securing the flue outlet to the firebox, and two screws securing the blower inlet housing to the firebox). Pull the assembly out of the slot and lower to the side. Do not remove the electrical connections at this time.

#### 3. Replacing air prover switch:

**Pressure switch:** Remove junction box cover and mark and disconnect wiring to the switch. Unscrew fitting connecting sampling tube to pressure switch, being careful not to kink the tube. Remove two screws from bracket that attaches pressure switch to junction box to remove switch. Install new pressure switch with bracket. Reattach sampling tube and wires removed from old switch and replace junction box cover.

**Sail switch:** Remove junction box cover, mark and disconnect wiring to the switch. Remove screws securing the switch to the junction box, and then remove the switch from the blower housing. Install new switch, ensuring the switch flap is correctly positioned in the blower housing. Reattach wires removed from old switch and replace box cover.

- If replacing blower, remove junction box cover, mark and disconnect each wire, and remove conduit fitting from junction box. Reinstall conduit fitting on new blower and reconnect wiring. Replace box cover.
- Reverse steps 1 – 2 to reinstall blower assembly.

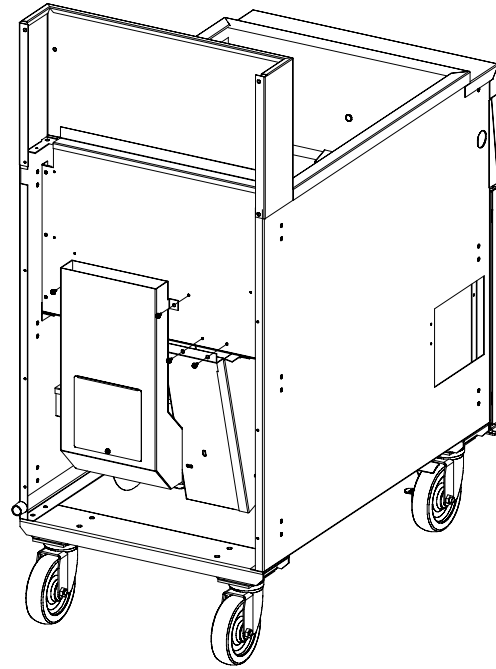

After removing screws (arrows), remove blower assembly from firebox by pulling outward.

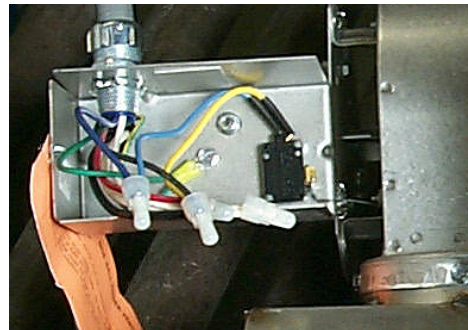

Blower junction box wiring. Mark wire locations before disconnecting each wire.

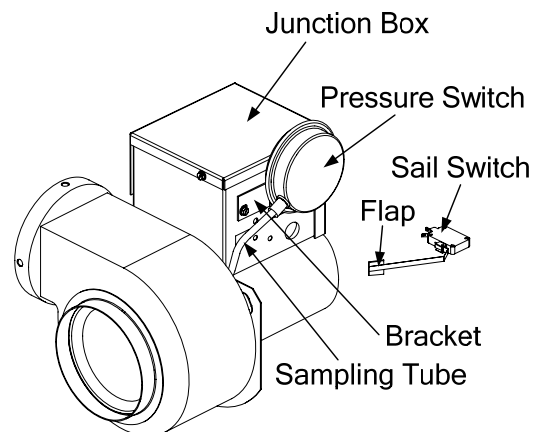

## 24G SERIES FLATBOTTOM GAS FRYERS

### CHAPTER 1: SERVICE PROCEDURES

---

#### 1.7.6 Replacing the Frypot

Unit should be at room temperature, disconnected from gas and electrical service, and empty of oil or shortening prior to beginning procedure.

##### 1.7.6.1 Frypot Baffle Inspection

1. Remove cabinet door(s) by holding door and lifting up on hinge pin. Current production model doors have spring-loaded pins that must be disengaged from the control panel and the bottom hinge. Remove marine edge (if applicable) by lifting up and off topcap and set aside.
2. The burner-tube retainer strip and burner tubes must be removed from the frypot/firebox being inspected. Remove the burner-tube shield and the burner-tube retainer from the burner-box and set aside. Lift the burner tubes up over each orifice and then pull outward to remove.

3. Disconnect the pilot gas-supply tube and remove the pilot assembly (without electronic ignition), or disconnect the sense wire and ignition cable and remove the direct-spark ignitor assembly (with electronic ignition). Inspect frypot baffles for signs of burn-through or damage. If baffle burn-through or damage is visible, proceed to the next section. If not, and no further service to frypot/firebox is required, reverse the above steps to reassemble the fryer.

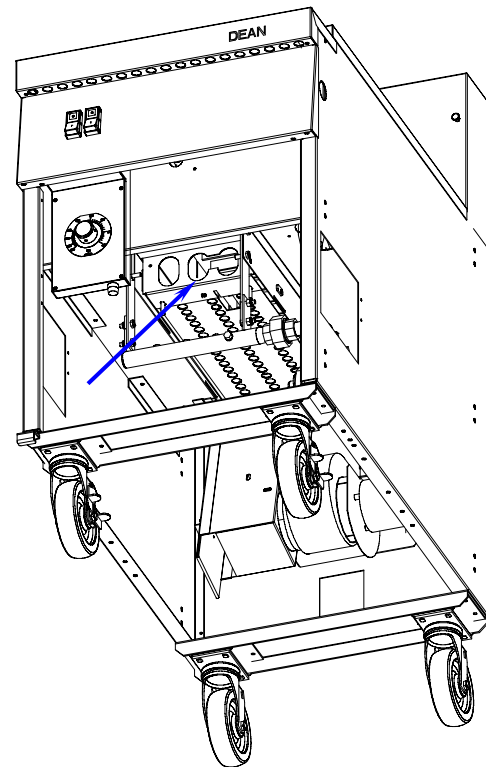

Inspect frypot baffles through burner tube opening (arrow) for signs of burn-through or damage.

## 24G SERIES FLATBOTTOM GAS FRYERS CHAPTER 1: SERVICE PROCEDURES

### 1.7.6.2 Frypot/Firebox Removal/Replacement Procedure

1. Perform Procedure 1.7.5, Removing/Replacing Blower Assembly or Air Prover Switch, Steps 1 – 4.
2. Disconnect the union at the gas valve. Remove four bolts connecting the burner manifold brackets to the burner box. Remove the burner manifold assembly and set aside.
3. Mark and disconnect drain-valve microswitch wiring. Remove elbow or drain-tee assembly, and then remove the drain valve/microswitch assembly.

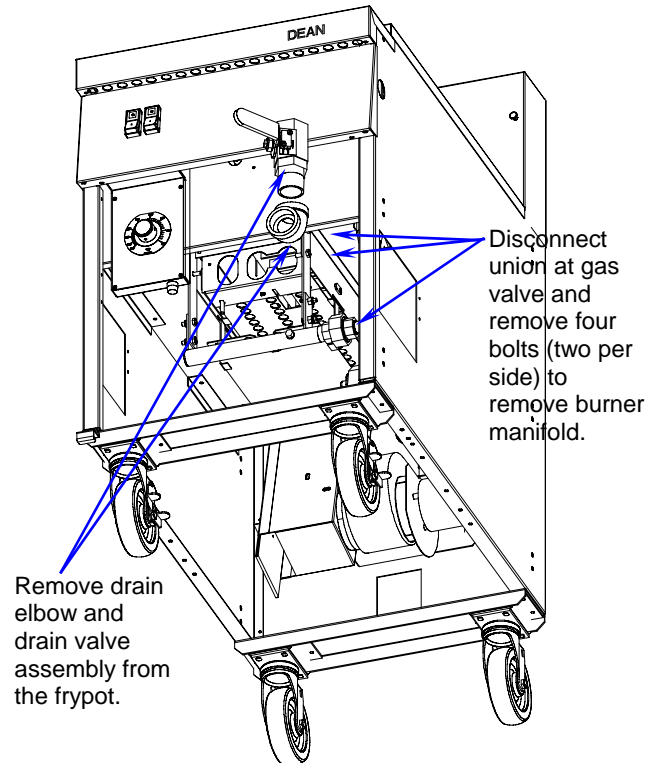

Disconnect union at gas valve and remove four bolts connecting burner manifold brackets to firebox, elbow and drain valve assembly from frypot.

4. Remove two screws from control panel and lower, using care not to stretch or distort switch/indicator light wiring (if applicable). If control panel is equipped with switches (see Section 1.7.2, Removing/Replacing Rocker Switches, for detail), or indicator lights, mark and disconnect wiring and set control panel aside.

Note: If equipped with indicator lights, use a pin-pusher to remove pins from main-harness connector, and then remove control panel.

5. Perform Procedure 1.7.1, Remove/Replace Temperature Probe or High-Limit Thermostat, Steps 7 – 11.

## 24G SERIES FLATBOTTOM GAS FRYERS

### CHAPTER 1: SERVICE PROCEDURES

6. Remove two screws securing topcap to wireway box. Remove topcap. Remove four screws securing wireway box to fryer cabinet (arrows) and carefully lower wireway box out of the way. Use care not to stretch or distort the wiring.
7. Remove two screws from the firebox heat shield (arrows), remove heat shield and set aside.

**NOTE: Steps 8 and 9 must be performed prior to frypot removal, especially on systems with built-in filtration. Failure to perform these steps will make frypot removal extremely difficult, and cause possible damage to firebox components during removal.**

8. Remove the burner box baffle by pushing the baffle up into the burner box until the baffle studs are clear of the slots. Tilt the baffle at an angle and remove it from the burner box.
9. Remove screws (two) securing the flame spreader to the burner box. Allow the spreader to drop down to clear the frypot baffles.

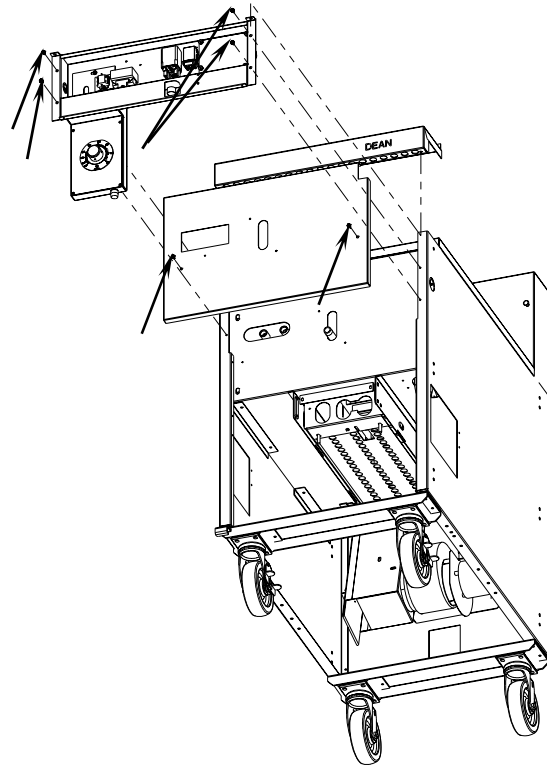

Remove topcap, wireway box and front heat shield to access firebox and frypot.

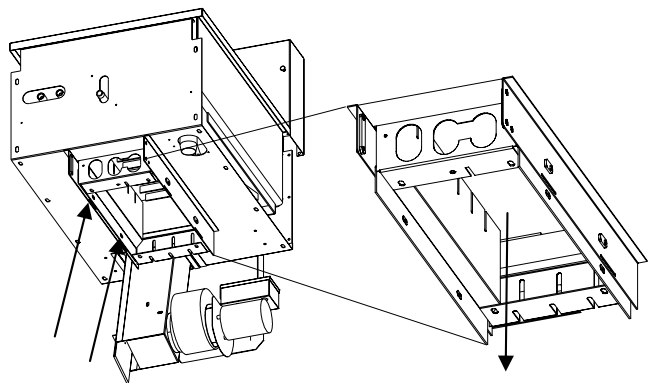

After removing burner-box baffle, remove screws (two) securing the flame spreader to the burner box. Allow the flame spreader to drop down in the burner box to clear the frypot baffles. Repeat for both sides.

## 24G SERIES FLATBOTTOM GAS FRYERS CHAPTER 1: SERVICE PROCEDURES

10. Remove firebox back, along with insulation from back of frypot. From the rear of the unit, use a prying bar to carefully pry the top assembly from the frypot and cabinet frame (single units only), and set aside. (The top assembly is secured to the frypot with high-temp silicone sealant.) On systems, remove individual pieces on the frypot being removed.

11. Pull the frypot back and up to remove. On fryers with built-in filtration systems, ensure the front oil-return inlet is clear of the firebox front before lifting frypot out of cabinet.

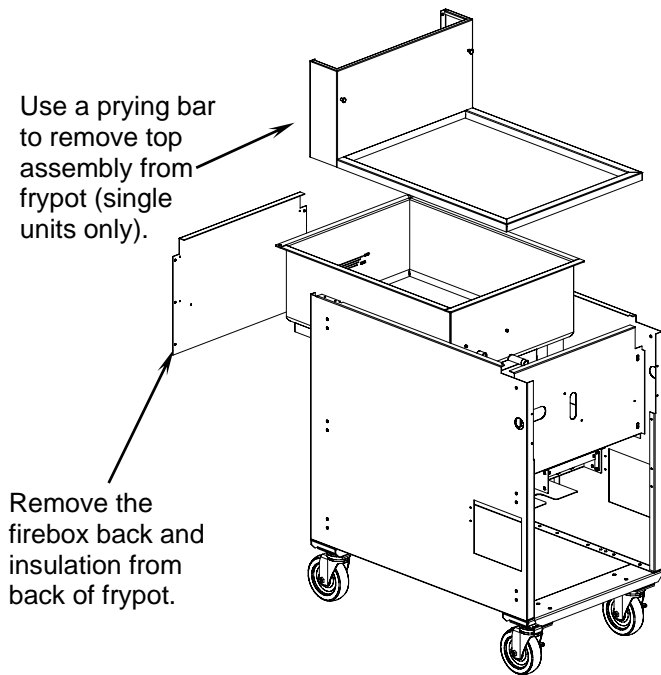

### If the Firebox Requires Replacement:

12. Remove screws (12) securing the firebox to the cabinet braces (arrows). Lift the firebox assembly back and up to remove from cabinet.





## 24G SERIES FLATBOTTOM GAS FRYERS

### CHAPTER 1: SERVICE PROCEDURES

13. Install new firebox into cabinet. Replace screws (12) removed during removal of the old firebox. Use spray adhesive (Zep Aero Tac High-Strength Spray Adhesive or equivalent) to install new insulation in firebox bottom as shown. The insulation must not go above the top of the burner-box center flange.

NOTE: Ensure the strip of insulation is properly affixed to the front blower-housing flange (arrow) prior to installing frypot. Failure to install the insulation strip will result in frypot-baffle burnout, blower damage and fryer malfunction, and will void all applicable warranties.

14. Install new frypot, using care not to damage the firebox insulation. Ensure the blower-housing insulation strip remains in place after installing the new frypot (arrow).

Reverse the above steps to reassemble the fryer. Use high-temp silicone to re-install the top assembly (single fryers) or joiner strips, flue caps, etc. (systems).



Install new insulation in firebox using spray adhesive, ensuring good contact between insulation and metal surfaces.

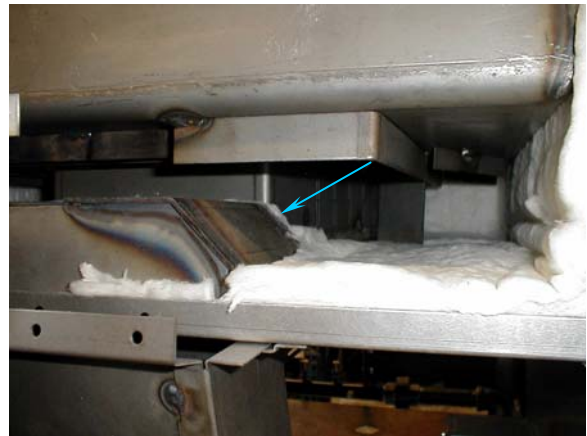

Ensure blower-housing insulation strip remains in place after installing the new frypot (arrow).

## 1.8 Troubleshooting and Problem Isolation

This section is intended to provide technicians with a general knowledge of the broad problem categories associated with this equipment, and the probable causes of each. With this knowledge, the technician should be able to isolate and correct any problem encountered.

Problems you are likely to encounter with 24G Series Flatbottom fryers can be grouped into five categories:

1. Ignition failures
2. Improper burner functioning
3. Improper temperature control
4. Filtration problems
5. Leakage



## 24G SERIES FLATBOTTOM GAS FRYERS

### CHAPTER 1: SERVICE PROCEDURES

---

The probable causes of each category are discussed in the following sections. Troubleshooting guides are included in **Section 1.9** to assist in identifying some of the more common problems.

#### 1.8.1 Ignition Failures

Ignition failure occurs when the ignition module fails to sense a flame within the 11-second time delay period and locks out. Turn the fryer off, locate and correct the problem, then turn fryer back on to clear the module lock.

There are three primary reasons for ignition failure, listed in order of probability:

1. Problems related to the gas and/or electrical power supplies.
2. Problems related to the electronic circuits.
3. Problems related to the gas valve.

#### Problems Related to the Gas and/or Electrical Power Supplies

The main indicator is that an entire battery of fryers fails to light. Verify that the quick disconnect hose is properly connected, the fryer is connected to power, the main gas supply valve is open, and the circuit breaker for the fryer electrical supply is not tripped. Some fryers are equipped with a fryer reset-switch that must be reset each time the fryer is turned off.

#### Problems Related to the Electronic Circuits

If gas and electrical power are supplied to the fryer, the next most likely cause of ignition failure is a problem in the 24 VAC circuit of fryers equipped with electronic ignition systems, or in the pilot system for those without electronic ignition. If the fryer is equipped with an Under Fryer Filter (UFF) filtration system, first verify that the drain valve is fully closed. (The valve is equipped with a microswitch that must be closed for power to reach the gas valve. Often, although the valve handle appears to be in the closed position, the microswitch is still open.) If the valve is fully closed, or the fryer does not have a filtration system, refer to the troubleshooting guides in this chapter.

#### Problems Related to the Gas Valve

If the problem is not in the 24 VAC circuit or pilot system, it is most likely in the gas valve itself, but before replacing the gas valve, refer to the troubleshooting guides in this chapter.

## 24G SERIES FLATBOTTOM GAS FRYERS

### CHAPTER 1: SERVICE PROCEDURES

---

#### 1.8.2 Improper Burner Functioning

With problems in this category, the burner ignites but exhibits abnormal characteristics such as "popping", incomplete lighting of burner, fluctuating flame intensity, and flames "rolling" out of the fryer.

**"Popping"** indicates delayed ignition. In this condition, the main gas valve is opening but the burner is not immediately lighting. When ignition does take place, the excess gas "explodes" into flame, rather than smoothly igniting.

The primary causes of popping are:

- Incorrect or fluctuating gas pressure
- Misdirected or weak pilot flame (non-electronic ignition)
- Clogged burner orifices
- Clogged burners
- Inadequate make-up air
- Heat damage to the controller or ignition module
- An out-of-adjustment ignitor or broken ignition wire
- A defective ignition module

If popping occurs only during peak operating hours, the problem may be incorrect or fluctuating gas pressure. Verify that the incoming gas pressure (pressure to the gas valve) is in accordance with the appropriate CE or Non-CE requirements listed in the Installation and Operation manual that came with the fryer, and that the pressure remains constant throughout all hours of usage. Refer to **Adjusting Burner Manifold Pressure** in Section 1.4 if burner manifold pressure is suspected of being incorrect.

If popping is consistent during all hours of operation, verify that the pilot is properly positioned above the burner orifice and that the pilot pressure is correct. Correct pilot pressure is indicated by a flame 1 to 1½" long. Refer to Section 1.5 for pilot adjustment procedure.

On systems equipped with electronic ignition, verify that the ignitor is properly adjusted (electrode tip and ignitor positioned properly over middle burner).

Clogged burners and burner orifices are also likely causes of delayed ignition. Clogged burners are indicated by uneven flame or partial flame on the burner face. Clogged orifices are indicated by no flame.

Another cause of popping is an insufficient air supply or drafts that are blowing the pilot flame away from the burner. Check for "negative pressure" conditions in the kitchen area. If air is flowing into the kitchen area, more air is being exhausted than is being replenished and the burners may be starved for air.

## 24G SERIES FLATBOTTOM GAS FRYERS

### CHAPTER 1: SERVICE PROCEDURES

---

If the fryer's gas and air supplies are okay, the problem most likely is with one of the electrical components. Examine the ignition module for signs of melting/distortion and/or discoloration due to excessive heat build-up in the fryer. (This condition usually indicates improper flue performance.). Also, examine the controller for the same conditions. A melted or distorted ignition module is automatically suspect and should be replaced, but unless the condition causing excessive heat in the fryer is corrected, the problem is likely to recur.

Next, ensure the ignition wire is connected properly at both ends and examine it for obvious signs of damage. Again, if damage is due to excessive heat in the fryer, that problem must also be corrected.



**MAKE SURE YOU ARE HOLDING THE INSULATED HANDLE OF THE SCREWDRIVER AND NOT THE BLADE. THE SPARKING CHARGE IS APPROXIMATELY 25,000 VOLTS.**

Check for proper operation by disconnecting the wire from the ignitor, inserting the tip of a screwdriver into the terminal, and holding it near the frame of the fryer as the power switch is placed in the "ON" position. A strong, blue spark should be generated for at least 11 seconds.

*Fluctuating flame intensity* is normally caused by either improper or fluctuating incoming gas pressure, but may also be the result of variations in the kitchen atmosphere. Verify incoming gas pressure in the same way as for "popping", discussed in the preceding paragraphs. Variations in the kitchen atmosphere are usually caused by air conditioning and/or ventilation systems starting and stopping during the day. As air conditioning/ventilation systems start and stop, the pressure in the kitchen may change from positive or neutral to negative, or vice versa. Changes in airflow patterns may affect flame intensity.

*Flames "rolling" out of the fryer* are usually an indication of negative pressure in the kitchen. Air is being sucked out of the fryer enclosure and the flames are literally following the air. If negative pressure is not the cause, check for high burner-manifold gas pressure in accordance with the procedures in Section 1.4. An obstructed flue or a faulty blower, which prevents the fryer from properly exhausting, may also be the cause.

*Excessively noisy burners*, especially with *flames visible above the flue opening*, may indicate that the burner gas pressure is too high or the gas valve vent-tube is blocked (if applicable). If the gas pressure is correct, and the vent-tube is unobstructed (if applicable), the gas valve regulator is probably defective.

## 24G SERIES FLATBOTTOM GAS FRYERS

### CHAPTER 1: SERVICE PROCEDURES

---

#### 1.8.3 Improper Temperature Control

Temperature control, including the melt cycle, is a function of several interrelated components, each of which must operate correctly. The principal component is the temperature probe. Depending upon the specific configuration of the fryer, other components may include the Thermatron board, the controller itself, and the ignition module.

Improper temperature control problems can be categorized into melt cycle problems and failure to control at setpoint.

##### Failure to Control at Setpoint

In fryers equipped with a Thermatron temperature controller, the #1 problem may be with the temperature probe improperly positioned. Other causes may be the Thermatron board or the potentiometer. Possible causes are that the potentiometer is out of calibration, or the temperature probe or Thermatron board is defective. Refer to Section 1.6 for instructions on calibrating the Thermatron temperature controller.

#### 1.8.4 Filtration Problems

Whenever the complaint is "the pump is running, but no oil is being filtered", check the filter paper or filter leaf (screen) connections and ensure they are properly connected. Ensure the filter paper or filter leaf is not clogged with food debris or sediment and is properly assembled.

If the pump motor overheats, a circuit breaker in the filter circuit will trip and the motor will not start until it is reset. If the pump motor does not start after pressing the circuit breaker, press the red reset switch located on the rear of the motor. If the pump then starts, something caused the motor to overheat. Maybe several frypots were filtered one after the other and the pump got hot. Letting the motor cool down for at least a half-hour is all that is required in this case. More often, the pump overheated for one of the following reasons:

- Shortening was solidified in the filter leaf or filter lines.
- The operator attempted to filter unheated oil or shortening. Cold oil and shortening are thicker and cause the pump motor to work harder and overheat.

If the motor runs but the pump does not, there is a blockage in the pump. An incorrectly assembled filter leaf allows food particles and sediment to pass through the filter pan and into the pump. When sediment enters the pump, the gears bind up causing the motor to overheat, tripping the thermal overload. Particles large enough to clog the pump may indicate that the crumb tray is not being used, and that the filter leaf is not properly assembled. Solidified shortening in the pump will produce the same result.

## 24G SERIES FLATBOTTOM GAS FRYERS

### CHAPTER 1: SERVICE PROCEDURES

A pump seized by debris or hard shortening must be disassembled, cleaned and reassembled as follows:

1. Disconnect power to the filter system.
2. Remove the front cover of the pump to access the gears inside, if the pump is accessible while still inside the cabinet. If the front cover is not accessible, the pump must be removed from the pump motor (remove input/output plumbing from the pump prior to removing pump). Remove setscrews to disengage the pump from the motor.

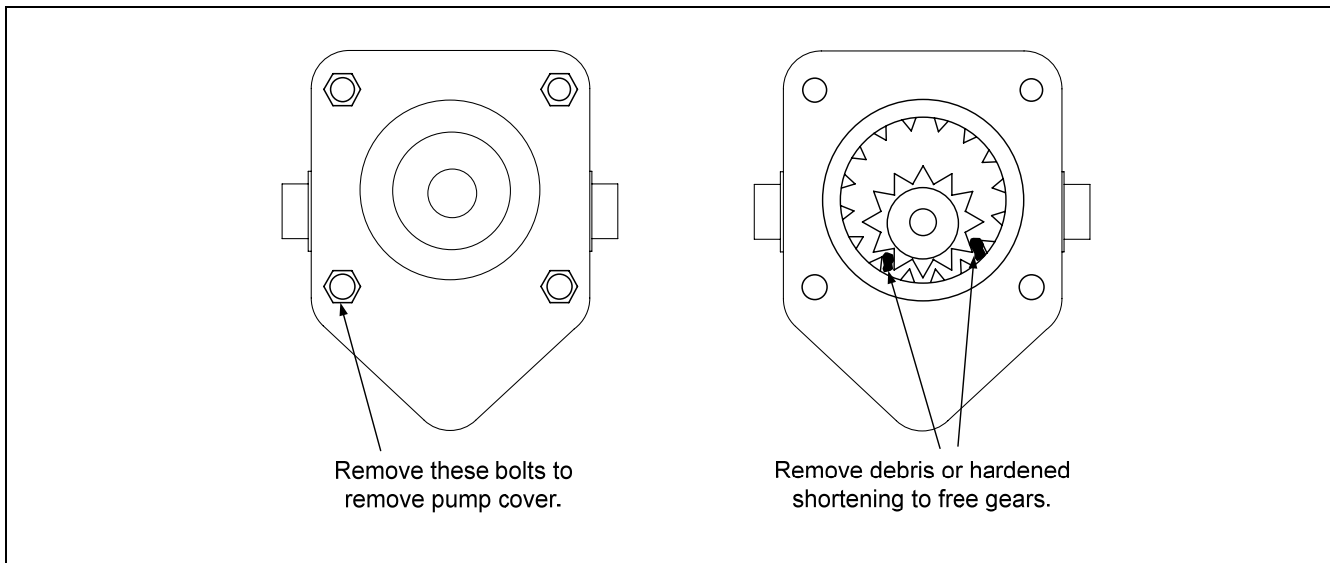

3. Prior to reassembly, the inside housing must be clean and free of any sediment or debris. Failure to completely clean the inside housing and ring gear will cause gear binding after reassembly.
4. During reassembly, partially install the housing bolts in a star pattern, leaving a  $\frac{1}{8}$ -inch (3.18 mm) gap between the cover and housing flanges. Ensure there is no shortening or oil in the filter pan, and that the filter pan is disconnected. With the motor running slowly draw the cover in, evenly tightening the housing bolts. When the cover is snug on the housing tighten all bolts to 15 inch-lbs (1.7 Nm) ensuring that the pump is working correctly. Turn the motor off.

The electronics of the SUFF/UFF filtration system are simple and straightforward. Microswitches attached to handles for each vat and wired in parallel provide the 24 VAC required to activate the pump relay coil. When the handles are moved to the ON position, the activated pump relay coil pulls the pump motor switch in, supplying power to the pump motor.

Filter systems equipped with oil-return heaters are wired into the 120 VAC source, which remains energized as long as the unit is plugged in.

## 24G SERIES FLATBOTTOM GAS FRYERS CHAPTER 1: SERVICE PROCEDURES

---

### 1.8.5 Leakage

Frypot leaks are usually due to improperly sealed high-limit, temperature probe or oil-return and drain fittings. When installed or replaced, each of these components must be sealed with Loctite PST567 sealant or equivalent to prevent leakage. In very rare cases, a leak may develop along one of the welded corners of the frypot. When this occurs, the frypot must be repaired or replaced.

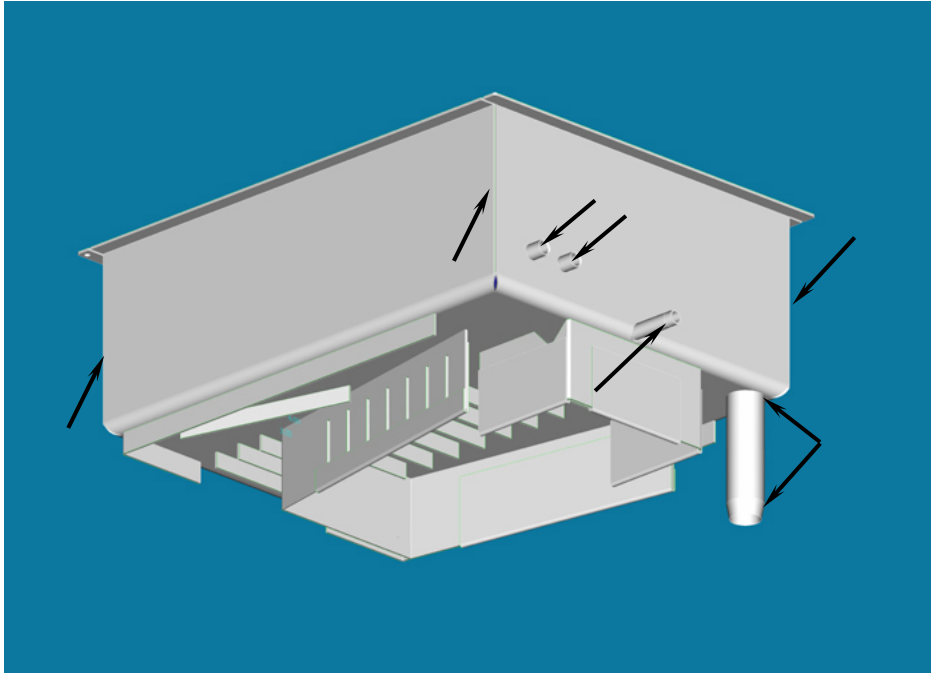

Frypot locations (indicated by arrows) where potential leaks could occur.

**24G SERIES FLATBOTTOM GAS FRYERS  
CHAPTER 1: SERVICE PROCEDURES**

## 1.9 Troubleshooting Guides

The following procedures **must be performed** by an ASA, and are provided as an aid to expedite troubleshooting and repair of 24G Series frying systems.

### 1.9.1 Pilot Burner Malfunctions

PROBLEM	CORRECTIVE ACTION
<b>Pilot will not ignite; no evidence of gas at pilot burner.</b>	<ol style="list-style-type: none"> <li>1. Ensure the combination gas valve is in PILOT position and that gas is available at the control valve (check quick-disconnect and/or gas-line connections).</li> <li>2. Remove pilot gas supply line and check for dirt. Blow out with compressed air if necessary, then reinstall.</li> <li>3. Check pilot burner orifice for dirt.</li> </ol>
<b>Pilot burner ignites but will not remain lit when gas knob is released.</b>	<ol style="list-style-type: none"> <li>1. Check that the lead from the thermocouple is tightly screwed into the pilotstat power bushing on the gas control.</li> <li>2. Remove end of thermocouple lead from pilotstat power unit bushing and clean with fine sandpaper. Also check that bushing is clean.</li> <li>3. Thermocouple possibly defective (millivolt output should be 12-28mv); replace.</li> <li>4. Pilot flame may be adjusted incorrectly. Adjust flame to 1-½" high by turning pilot flow adjustment screw.</li> </ol>
<b>Pilot burner ignites properly and burns properly, but goes out when the exhaust blower comes on.</b>	<ol style="list-style-type: none"> <li>1. With the exhaust blower in operation, the extra air causes the pilot to blow out. The pilot assembly may be too low between the burners. Adjust the pilot assembly to where the pilot hood is above the burners.</li> <li>2. Pilot flame may be adjusted too high and is on the verge of blowing out. Re-adjust lower.</li> <li>3. Pilot flame may be adjusted too low, even though it appears to be satisfactory. Re-adjust higher as described earlier.</li> </ol>

**24G SERIES FLATBOTTOM GAS FRYERS  
CHAPTER 1: SERVICE PROCEDURES**

**1.9.2 Main Burner Malfunctions**

PROBLEM	CORRECTIVE ACTION
<p><b>Main burner will not come on even though air blower is in operation; no gas pressure at main burner.</b></p>	<ol style="list-style-type: none"> <li>1. Check that the combination gas valve is ON.</li> <li>2. Check that the pilot is lit and is operating properly.</li> <li>3. Check high temperature safety switch. Replace if defective.</li> <li>4. Check air prover (pressure switch) as follows:  Ensure green prover light is on. If not, check for 24 VAC going into and coming out of the air prover pressure switch.</li> <li>5. Check air prover switch (sail switch) as follows:  Move actuating lever at switch to ensure it is not dragging in the slots (use long tool to avoid burns). If so, bend the arm carefully to clear the obstruction. Check the air prover switch for continuity and replace if defective.</li> </ol>
<p><b>Air blower is not operating, although power is present at the fryer.</b></p>	<ol style="list-style-type: none"> <li>1. Cooked product or other material may have fallen into the flue and lodged in the blower wheel, preventing it from turning. Clean out flue and blower wheel.</li> <li>2. Blower motor may have overheated and shut off. This condition will correct itself when motor cools (20 minutes). If problems with blower overheating persist, call for service.</li> <li>3. If fryer is equipped with a Thermatron controller, the temperature probe or the controller board may be defective.</li> </ol>
<p><b>Main burner flames are small and appear lazy; Oil does not come up to temperature quickly.</b></p>	<ol style="list-style-type: none"> <li>1. Check gas pressure at the pressure tap of the burner manifold. Use a standard water-type U-gauge manometer. With the burner in operation, the pressure should be about 4" W.C. on natural and 11" W.C. on propane (LP) gases. If not, unscrew the cover of the pressure regulator adjustment and turn the adjusting screw clockwise to increase gas pressure (or counterclockwise to decrease the pressure). Replace cover and plug.</li> </ol>
<p><b>There are signs of excessive frypot temperature; oil becomes discolored quickly.</b></p>	<ol style="list-style-type: none"> <li>1. Check the frypot for excessive build up of debris.</li> <li>2. Thermatron controller may be out of calibration. Re-calibrate in accordance with instructions in Section 1.6.</li> <li>3. Check gas pressure.</li> <li>4. Oil of inferior quality or used too long. Replace with quality oil.</li> </ol>



## 24G SERIES FLATBOTTOM GAS FRYERS

### CHAPTER 1: SERVICE PROCEDURES

#### 1.9.3 Indicator Lights

The fryer's indicator lights serve a diagnostic purpose. All lights are lit when the fryer is working properly. (The green light on the control panel will cycle on and off as the fryer calls for heat). Use the following procedures to isolate problems indicated by light combinations.

Turn the temperature dial to 400°F (204°C) to ensure the sensor will demand heat. Check all indicator lights in the fryer cabinet and on the control panel. [**Older units** may have power and reset switches with different colored lights (orange, amber, red, green white.). **Common Cabinet units** have a white power light and a green air prover light. Substitute the light color of the correct color switch with the respective "green light" switch in the following troubleshooting procedures. The control panel light colors haven't changed.]

When turning the power switch "ON" and resetting the safety (reset) switch, check for the following:

LIGHT INDICATION	PROBABLE CAUSE	CORRECTIVE ACTION
<b>GREEN LIGHT/POWER SWITCH IS "ON"</b>  <b>GREEN LIGHT/SAFETY (RESET) SWITCH IS "OFF"</b>  <b>GREEN LIGHT/CONTROL PANEL IS "OFF"</b>  <b>RED LIGHT/CONTROL PANEL IS "OFF"</b>	1. The drain valve is open.  2. The drain switch is defective.	1. Ensure the drain valve is completely closed, and then turn the reset switch to "ON".
<b>GREEN LIGHT/POWER SWITCH IS "OFF"</b>  <b>GREEN LIGHT/SAFETY (RESET) SWITCH IS "OFF"</b>  <b>GREEN LIGHT/ CONTROL PANEL IS "OFF"</b>  <b>RED LIGHT/CONTROL PANEL IS "OFF"</b>	1. No power to fryer.  2. Fuse is blown.  3. Reset switch circuit defective.	1. Check power source, power cords and breaker. Ensure that electricity is available to the fryer.  2. Replace fuse.  3. If fryer does not function after resetting the reset switch, contact an ASA for assistance.

# 24G SERIES FLATBOTTOM GAS FRYERS

## CHAPTER 1: SERVICE PROCEDURES

### 1.10 WIRING DIAGRAMS

**Note:** The diagrams in this section depict wiring as of the date of manual publication. It may not reflect design changes made to the equipment after publication. Always refer to the wiring diagram affixed to the unit when actually troubleshooting this equipment.

#### 1.10.1 24G Series Single Fryers: Non-CE without Boil-Out Switch

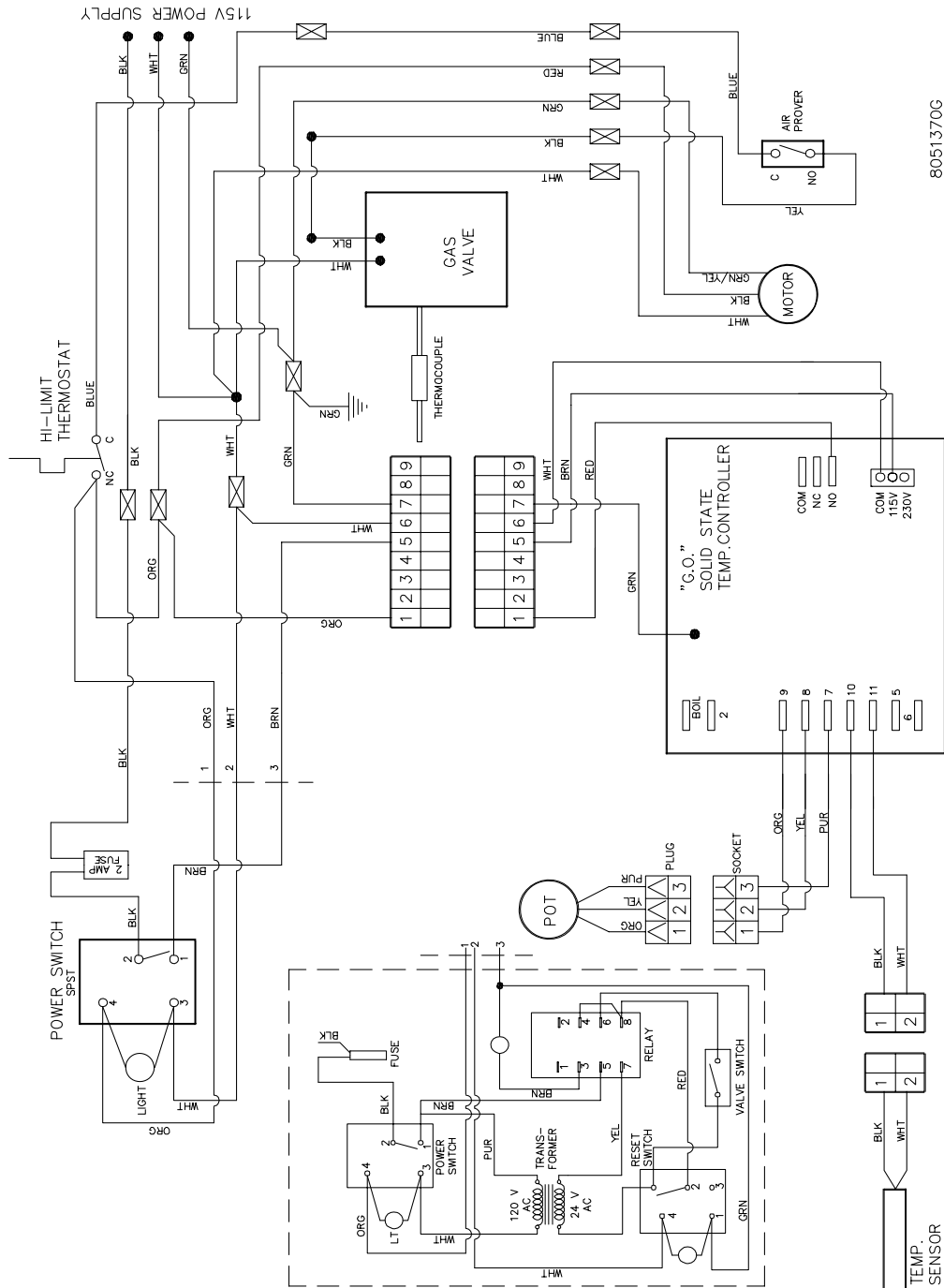

# 24G SERIES FLATBOTTOM GAS FRYERS

## CHAPTER 1: SERVICE PROCEDURES

### 1.10.2 24G Series Single Fryers, Non-CE with Boil-Out Switch

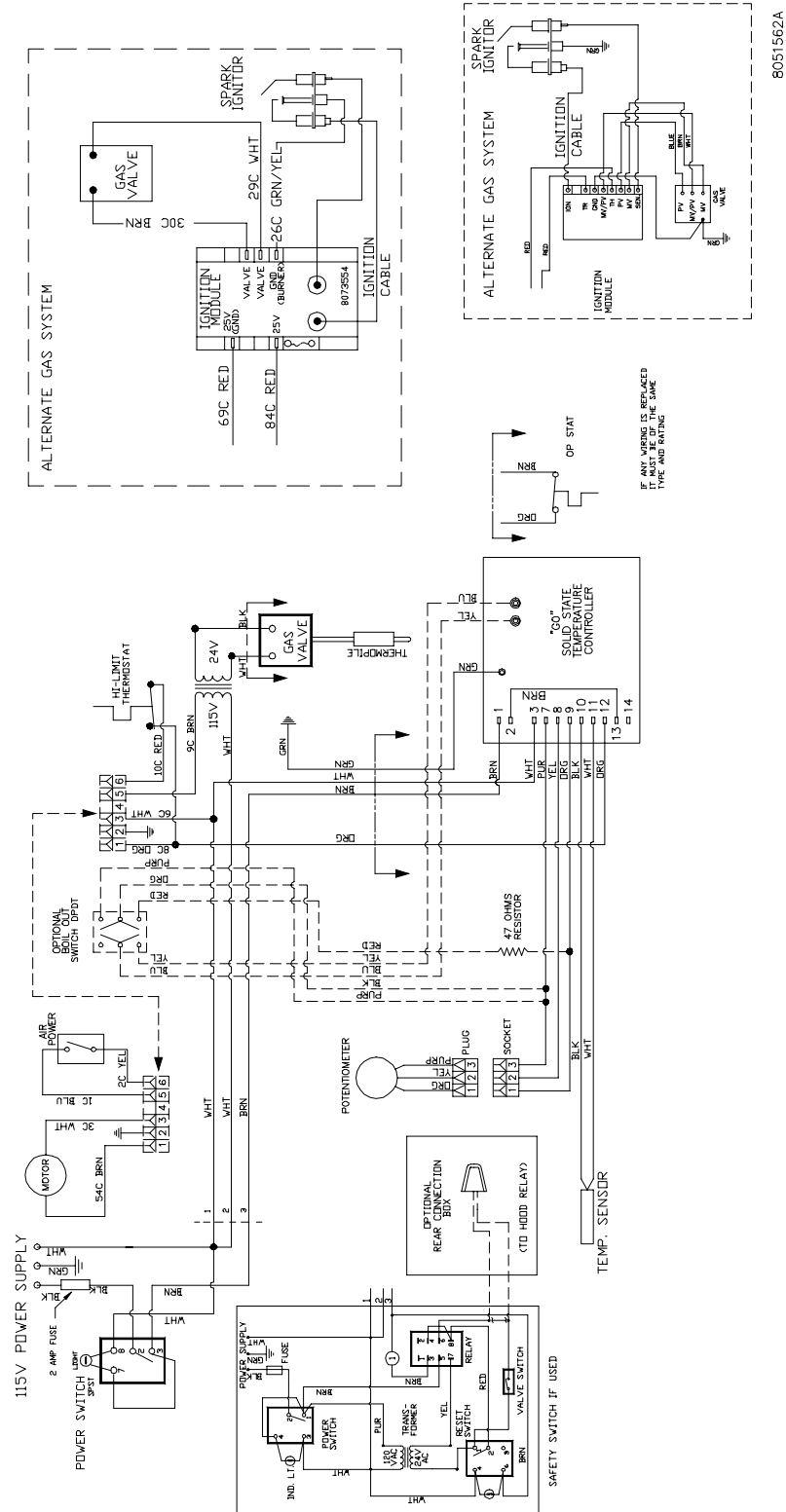

# 24G SERIES FLATBOTTOM GAS FRYERS CHAPTER 1: SERVICE PROCEDURES

## 1.10.3 24GTI With Drain Safety Switch, and Boil-Out Option Enabled – LJS

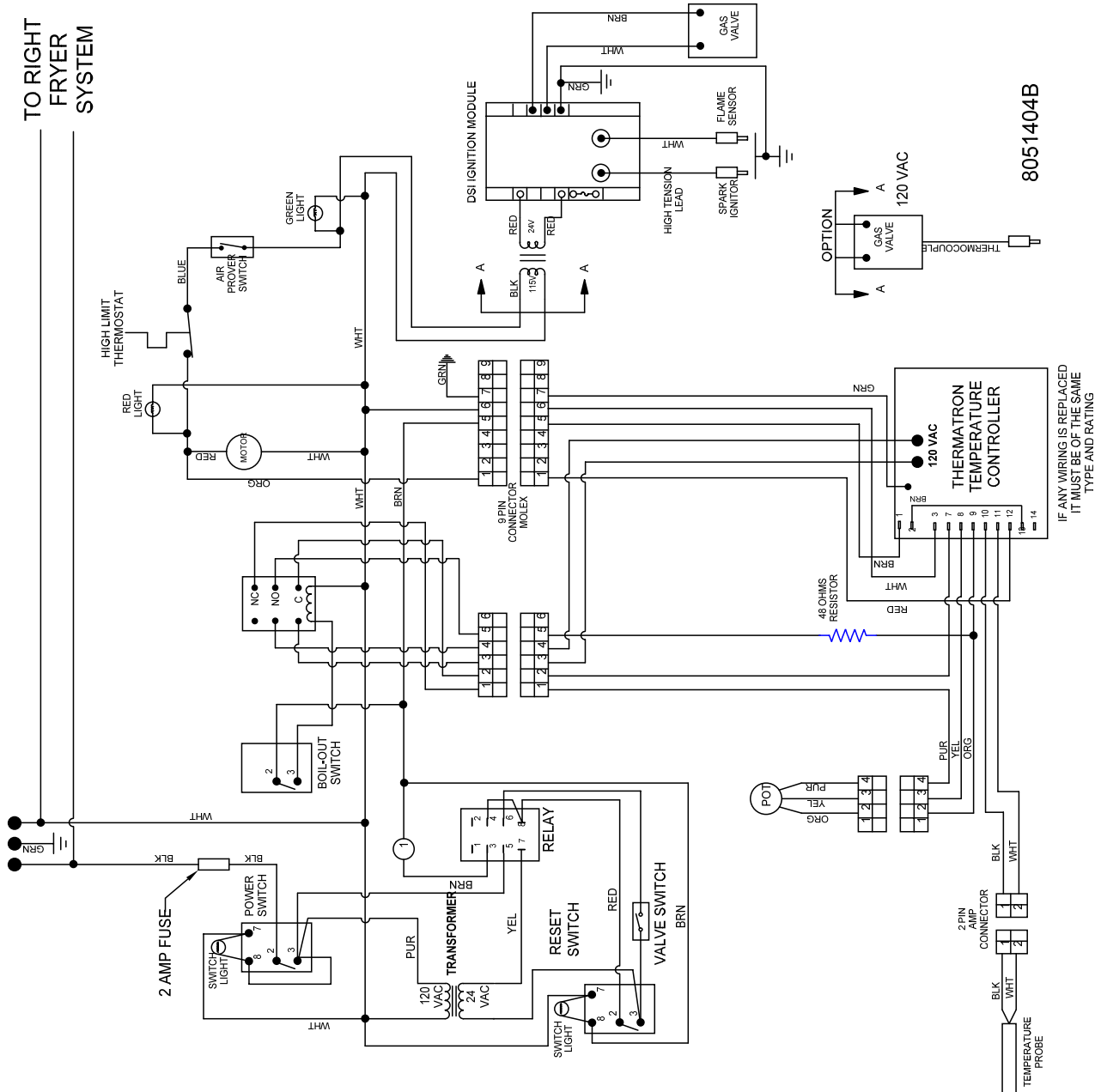

# 24G SERIES FLATBOTTOM GAS FRYERS

## CHAPTER 1: SERVICE PROCEDURES

### 1.10.4 24GTI with Drain Safety Switch, and Boil-Out Option Enabled – 120V Non-LJS

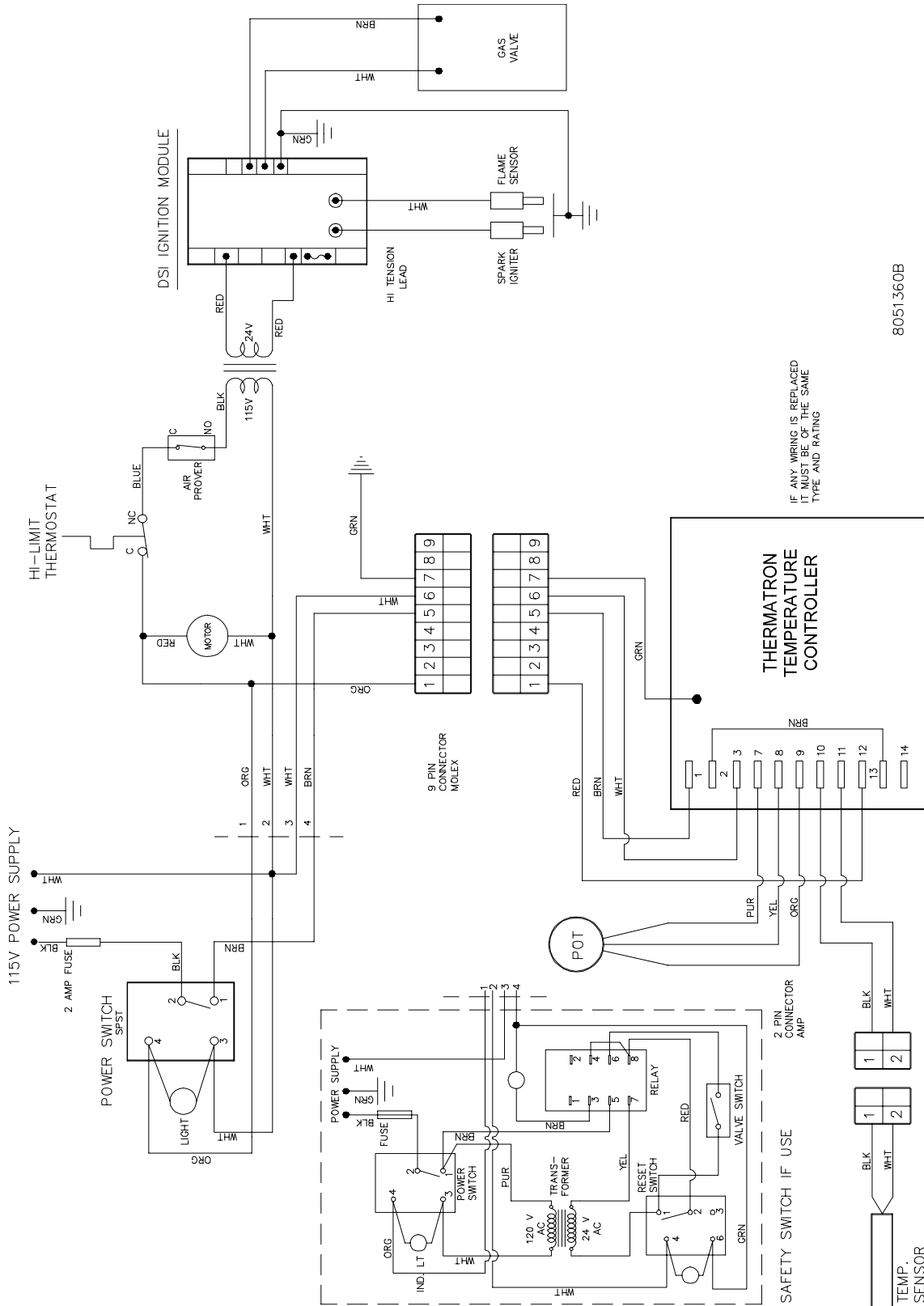

8051360B

# 24G SERIES FLATBOTTOM GAS FRYERS CHAPTER 1: SERVICE PROCEDURES

## 1.10.5 24GTI with Drain Safety Switch, and Boil-Out Option Enabled – 250V Non-LJS

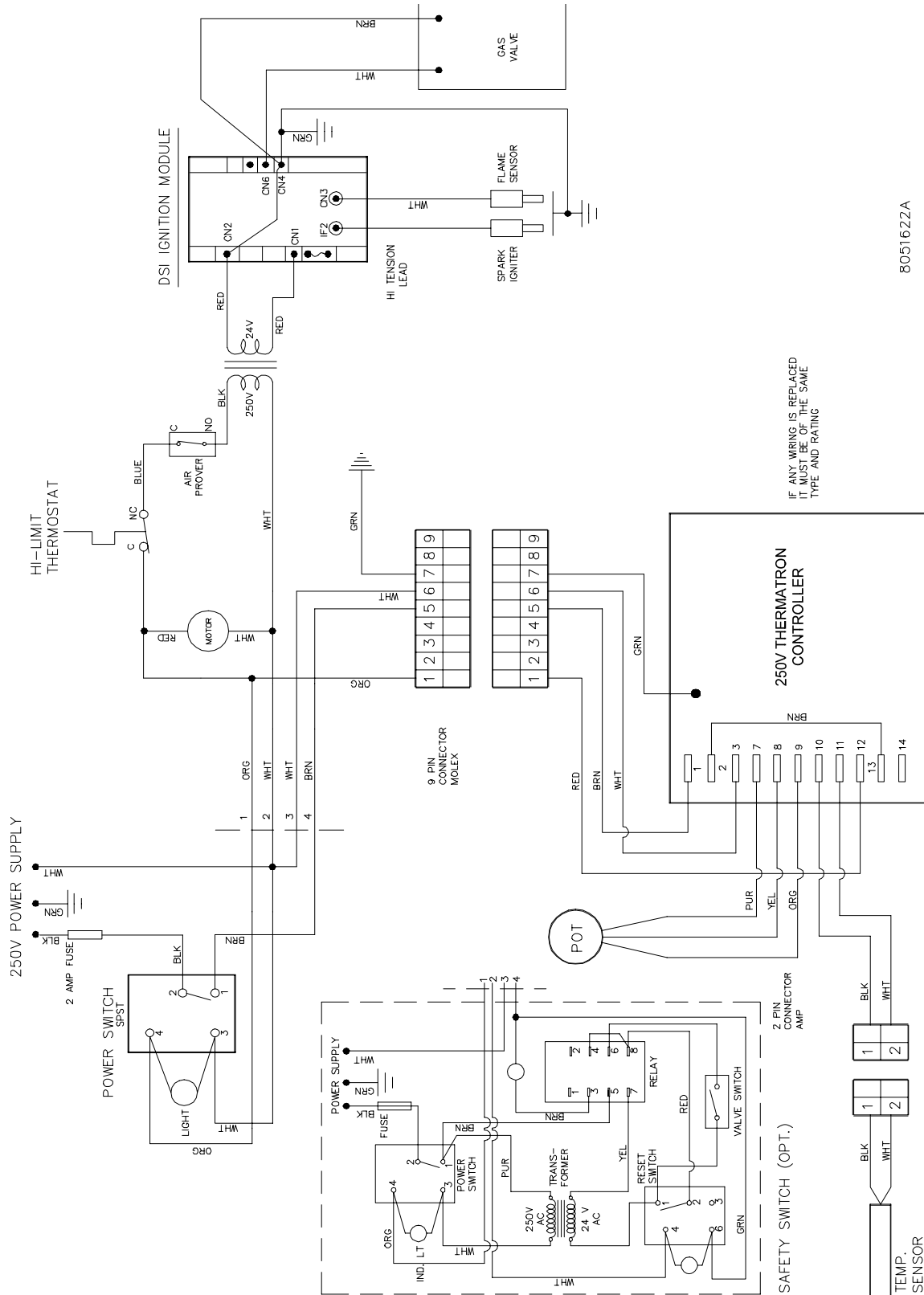

8051622A

# 24G SERIES FLATBOTTOM GAS FRYERS

## CHAPTER 1: SERVICE PROCEDURES

### 1.10.6 24GTI with Drain Safety Switch, and Boil-Out Option Disabled – KFC

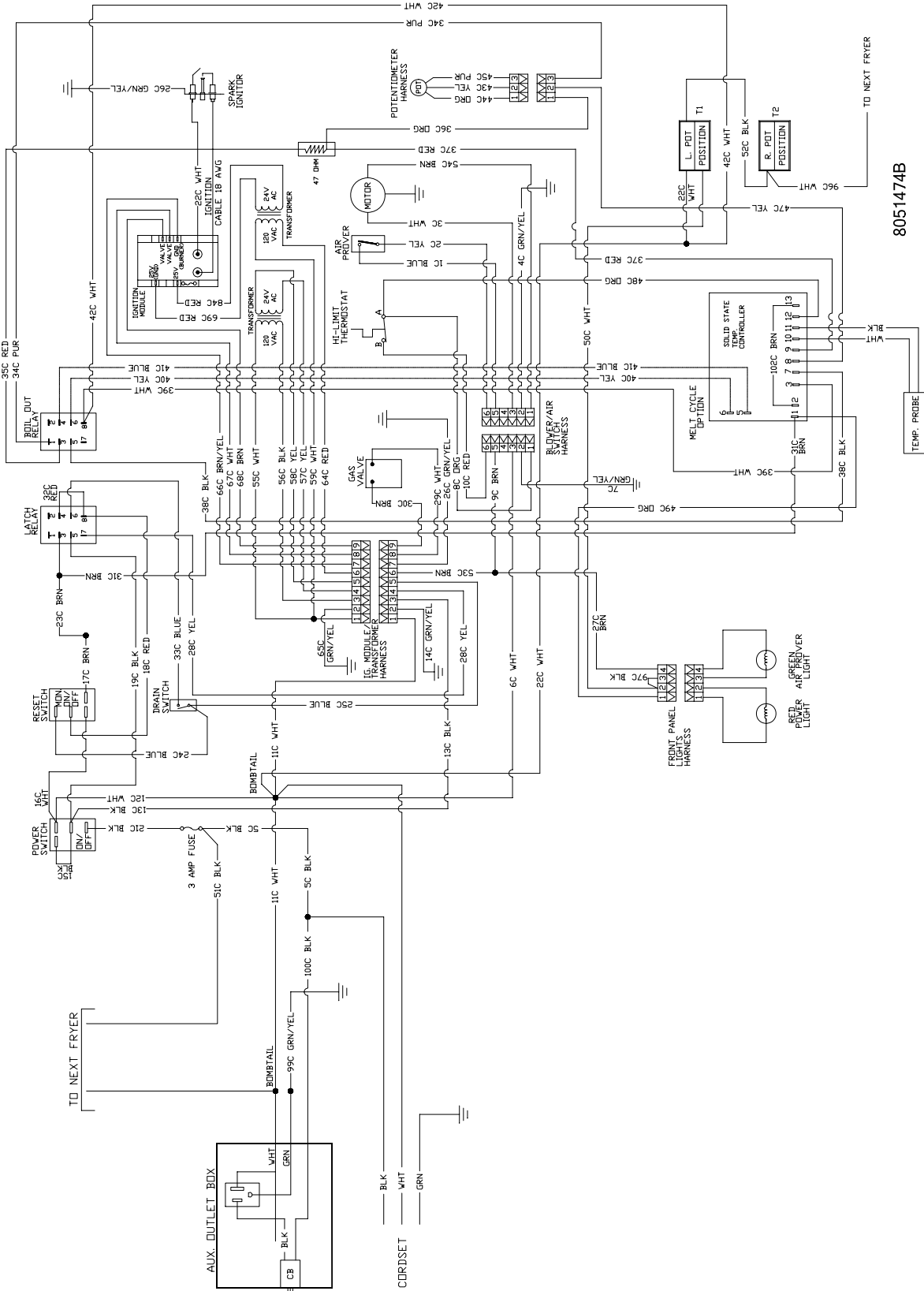

# 24G SERIES FLATBOTTOM GAS FRYERS

## CHAPTER 1: SERVICE PROCEDURES

### 1.10.7 24GTI With Drain Safety Switch, and Boil-Out Option Disabled – Non-KFC

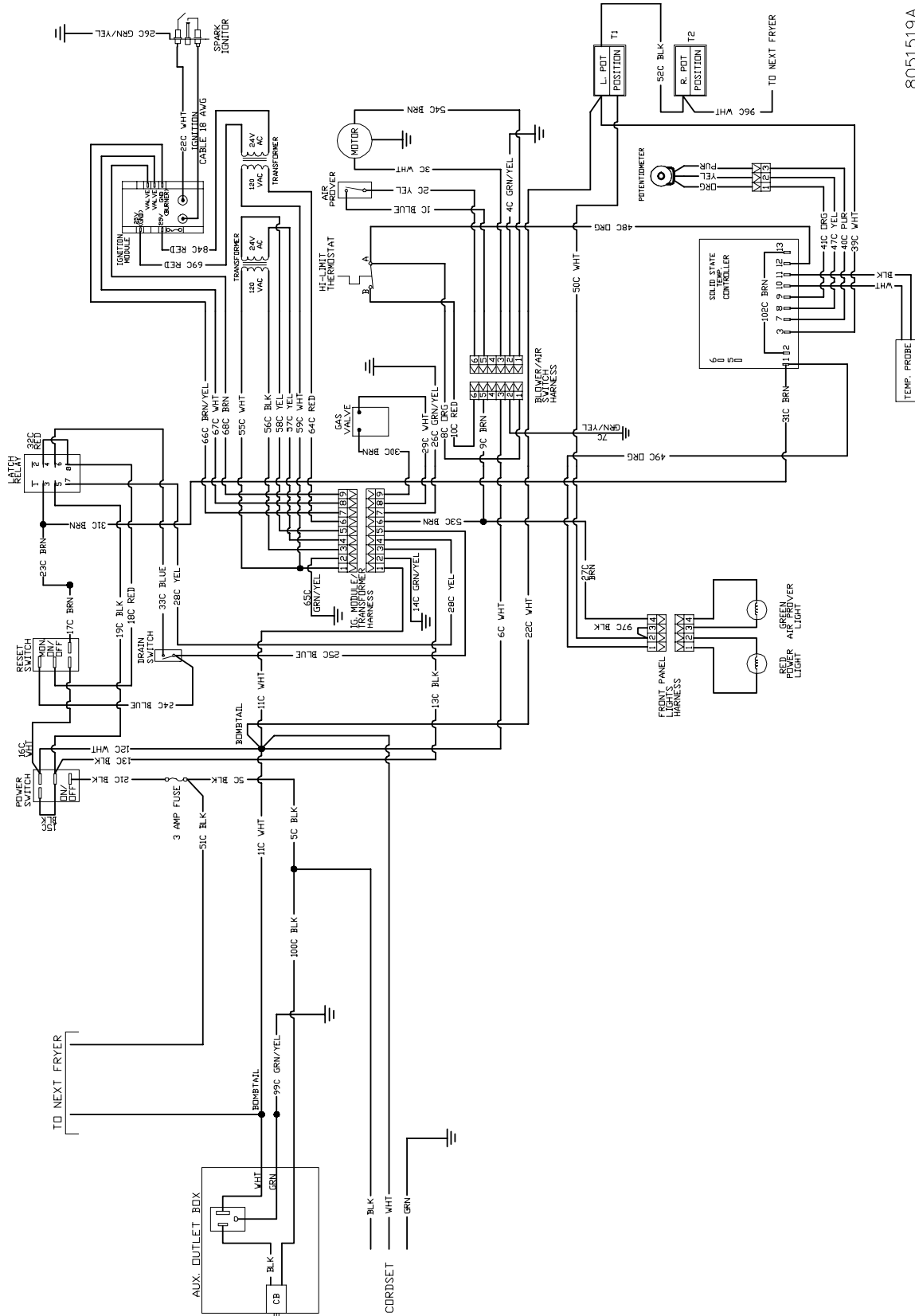

8051519A



# 24G SERIES FLATBOTTOM GAS FRYERS CHAPTER 1: SERVICE PROCEDURES

## 1.10.8 24G Series Single Fryers – CE-Approved

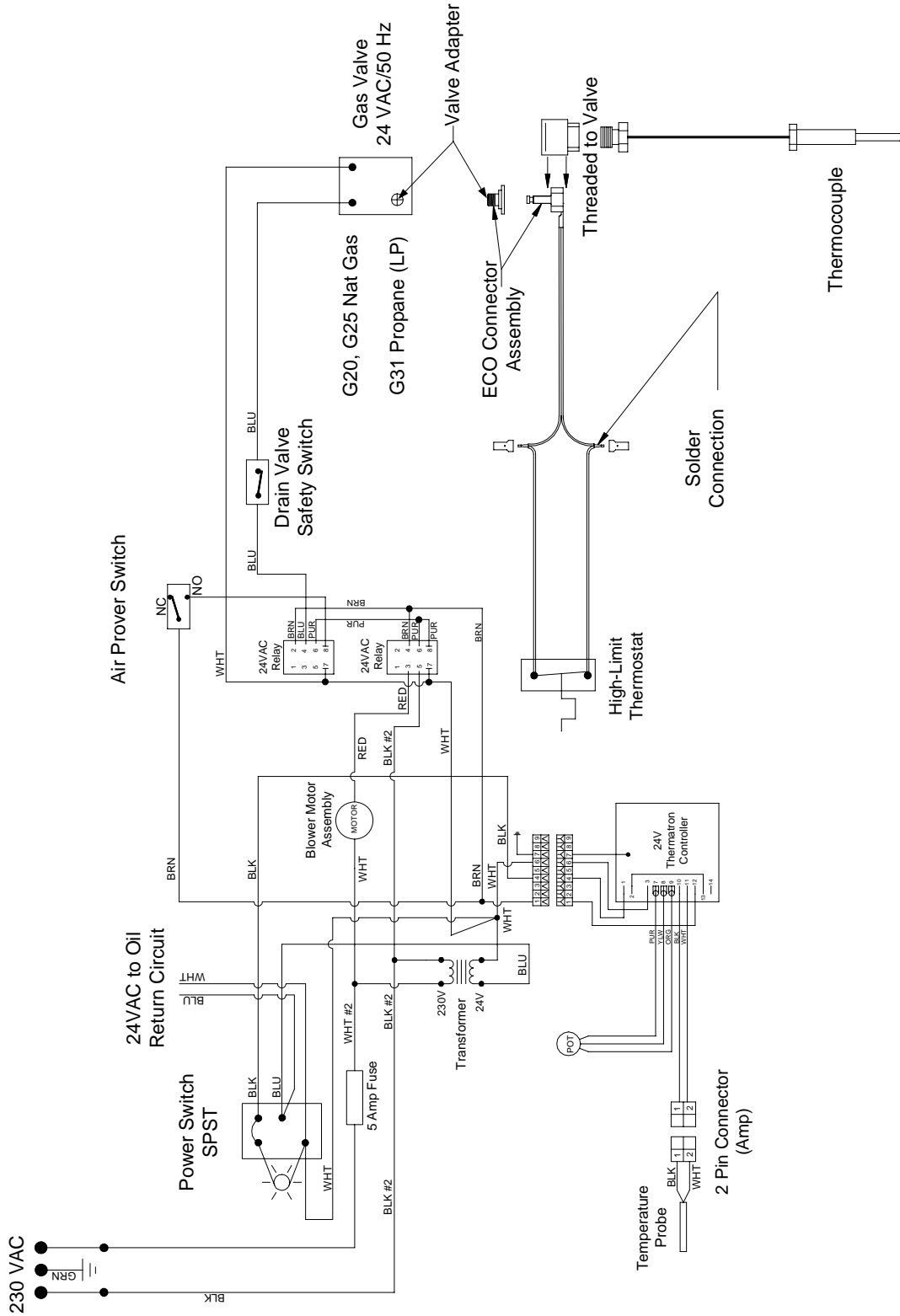

# 24G SERIES FLATBOTTOM GAS FRYERS CHAPTER 1: SERVICE PROCEDURES

## 1.10.9 Wiring, Standing Pilot – SCFC Models prior to May 2011

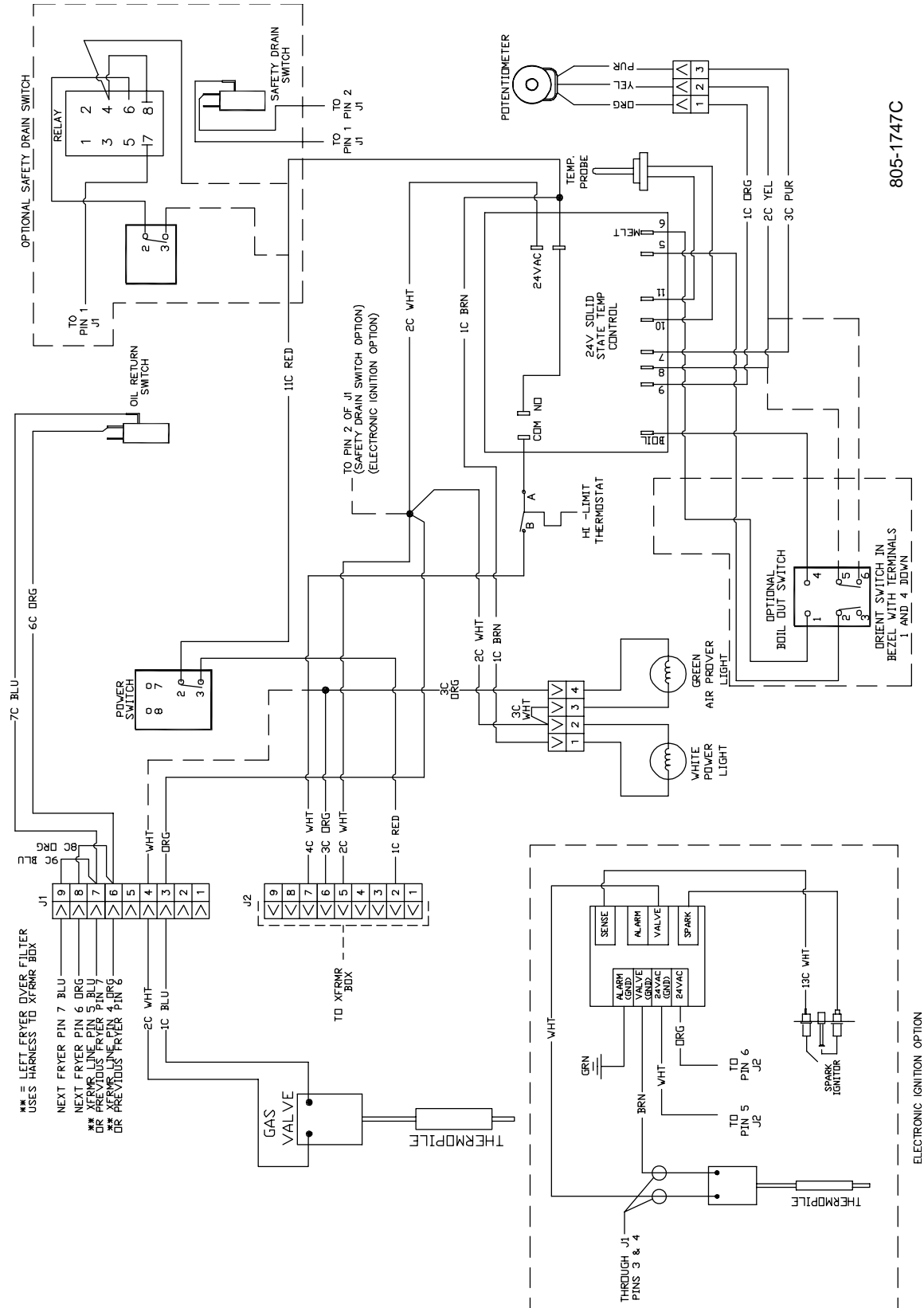

# 24G SERIES FLATBOTTOM GAS FRYERS CHAPTER 1: SERVICE PROCEDURES

## 1.10.10 Wiring, Standing Pilot – SCFC Models after May 2011

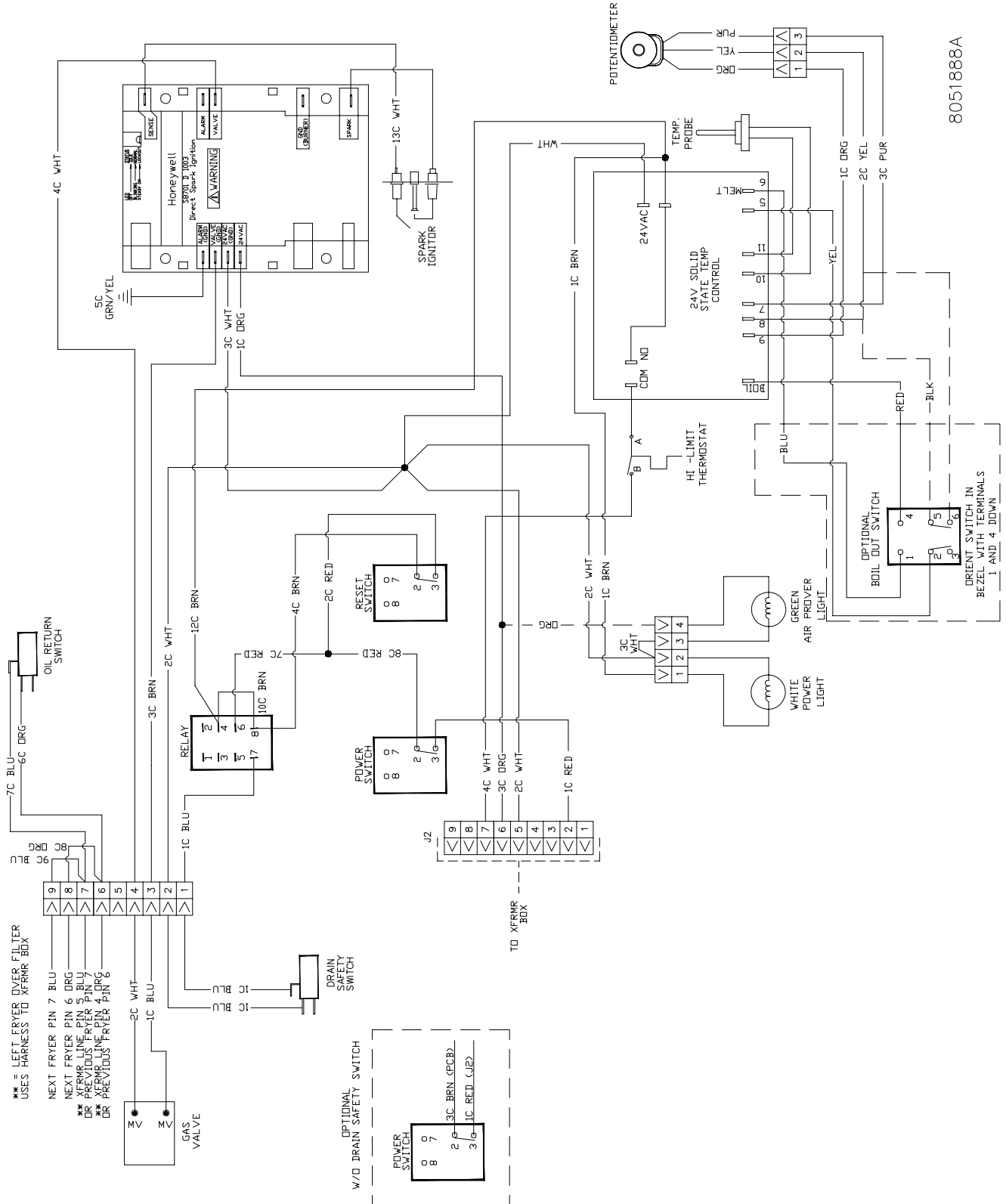

# 24G SERIES FLATBOTTOM GAS FRYERS

## CHAPTER 1: SERVICE PROCEDURES

### 1.10.11 24GTI Oil Return/Filter System

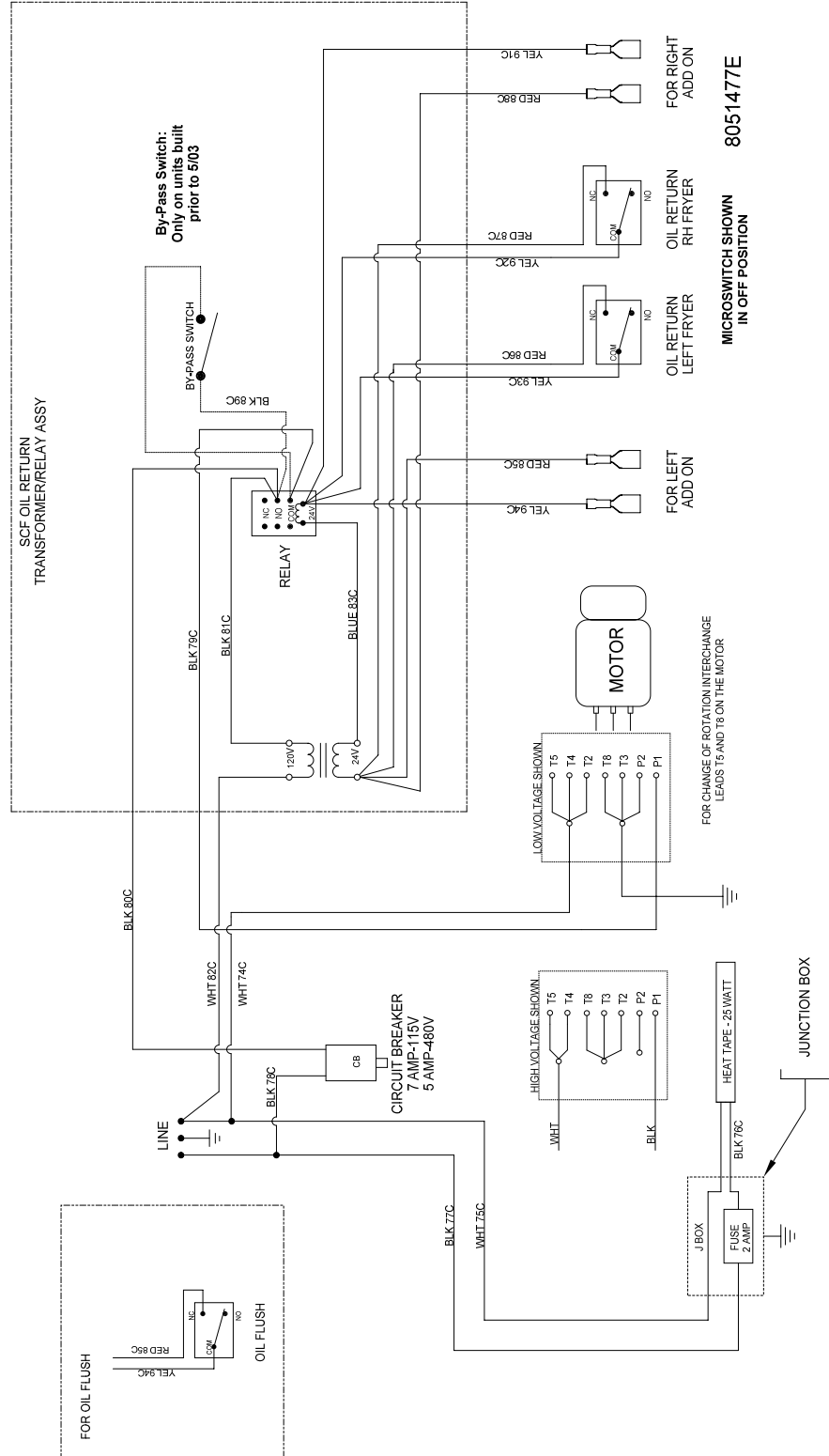

# 24G SERIES FLATBOTTOM GAS FRYERS

## CHAPTER 2: PARTS LIST

### 2.1 Blower Assembly and Combustion Air

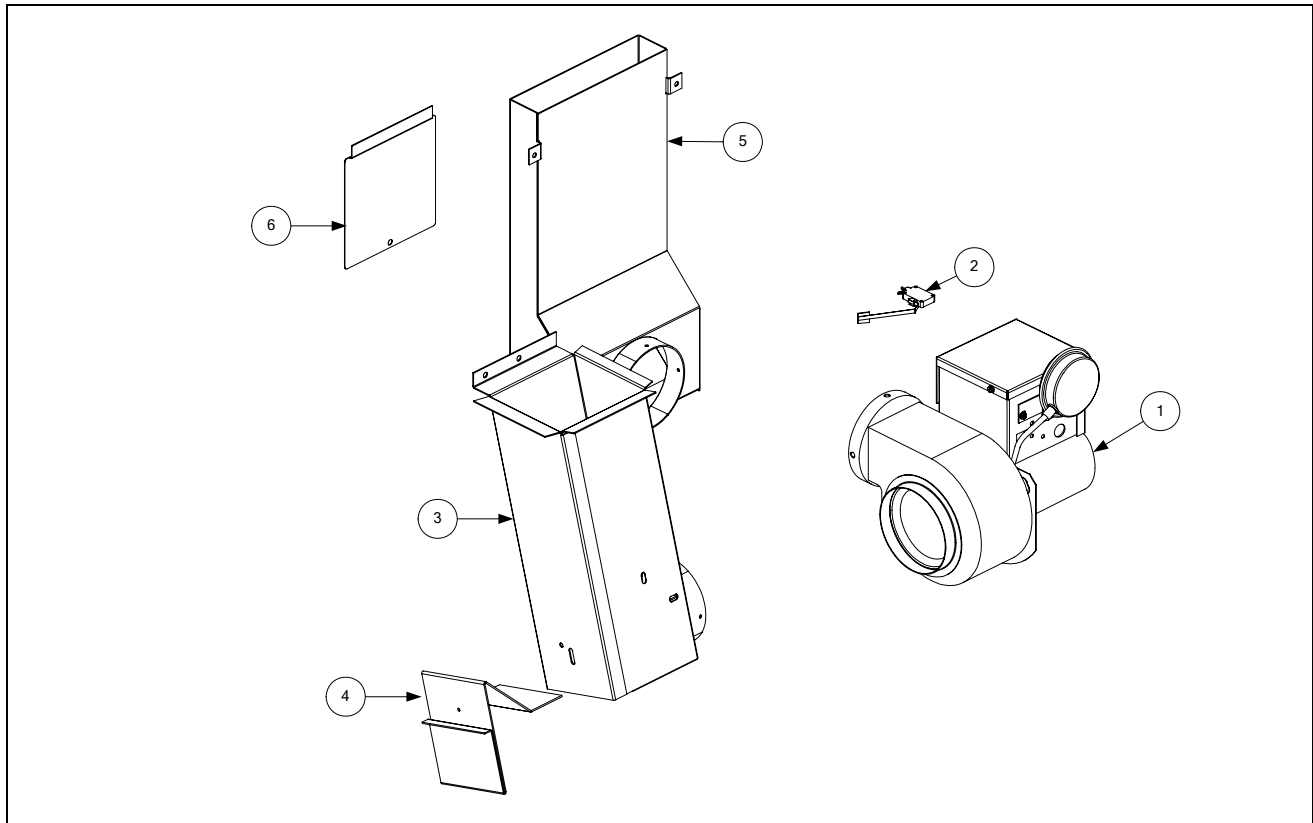

ITEM	PART #	COMPONENT
1		Motor, Blower Assembly
	108-0471SP	120V, Blower with Pressure Switch (non-CE)
	108-0470SP	230V, Blower with Pressure Switch (CE)
2	807-3746	Switch, Sail (Air Prover Switch – previous style fryers)
3	823-3162	Duct Assembly, Inlet
4	200-1428	Gate, Air Flow
5	823-3166	Duct Assembly, Outlet
6	200-1471	Door, Outlet Duct Access

\* Not illustrated.

24G SERIES FLATBOTTOM GAS FRYERS  
CHAPTER 2: PARTS LIST

2.2 Burner Manifold and Related Components

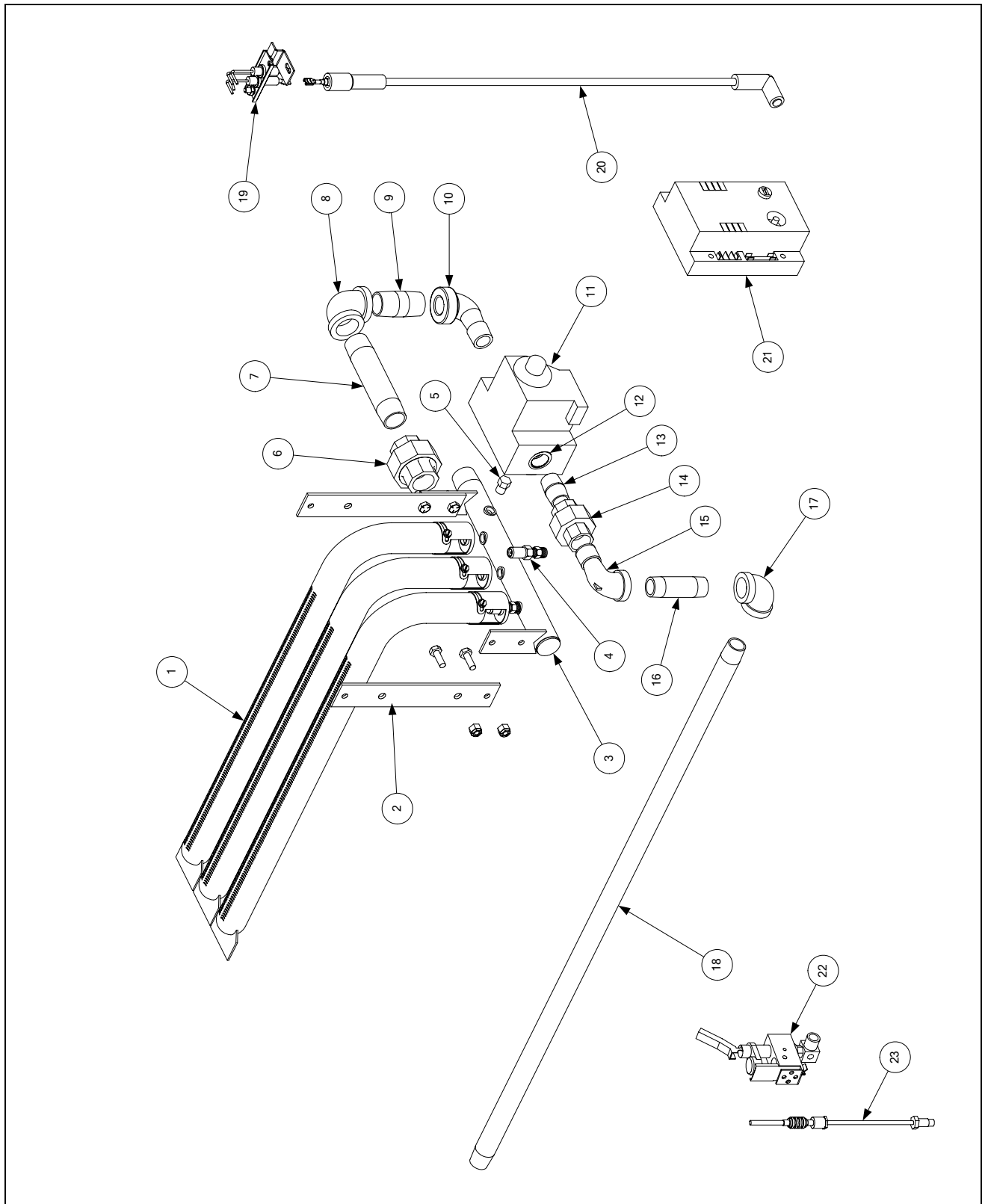

**24G SERIES FLATBOTTOM GAS FRYERS  
CHAPTER 2: PARTS LIST**

**2.2 Burner Manifold and Related Components (cont.)**

ITEM	PART #	COMPONENT
1	810-2129	Tube, Burner
2	200-1670	Support, Left or Right Manifold
3	810-2168	Burner Manifold Assembly
4		Orifice
	810-2827	2.82mm (#34) Natural Gas
	810-2830	1.78mm (#50) Propane (LP) Gas (use 810-2765 for high altitude)
5	813-0154	Plug, 1/8-inch NPT (Manifold Pressure Tap Plug)
6	813-0174	Union, 3/4-inch NPT Pipe
7	813-0300	Nipple, 3/4-inch NPT x 4 1/2-inch
8	813-0066	Elbow, 90° x 3/4-inch NPT
9	813-0112	Nipple, 3/4-inch NPT x 2-inch
10	813-0168	Elbow, 90° x 3/4-inch NPT Street
11		Valve, Gas
	807-3555	24V Natural (G20/G25) Honeywell
	807-3690	24V Propane (LP) (G31) Honeywell
	810-2156	120V Natural (G20/G25) Robertshaw
	810-2323	120V Propane (LP) (G31) Robertshaw
*	810-0691	Vent tube
12	813-0763	Bushing, 3/4-inch NPT to 1/2-inch NPT
13	813-0022	Nipple, 1/2-inch NPT x Close
14	813-0173	Union, 1/2-inch NPT Pipe
15	813-0165	Elbow, 90° x 1/2-inch NPT Street ( <i>for single fryers, use 45° 813-0342</i> )
16	813-0265	Nipple, 1/2-inch NPT x 2 1/2-inch
17	813-0062	Elbow, 90° x 1/2-inch NPT
18	813-0845	Nipple, 1/2-inch NPT x 2 9/4-inch ( <i>single fryers, use 2 4 1/2-inch 813-0788, 813-0729 23"</i> )
		<b>Electronic Ignition Components</b>
19	807-3556	Ignitor and Flame Sensor Assembly ( <i>does not include flame sensor wire or cable</i> )
*	106-4580	Ignitor Bracket, Flat Style ( <i>After Oct 2004</i> )
*	210-6184	Ignitor Bracket with bends ( <i>used prior to Oct 2004</i> )
20	106-1644SP	Ignition Cable, 21" ( <i>includes Rajah connector, use with sense wire 106-1645SP</i> )
*	106-3338SP	Ignition Cable, 36" ( <i>use with sense wire W5C518</i> )
*	807-3484	Rajah Connector ( <i>included with Item 20</i> )
21	807-0918	Module, Ignition Spark, Honeywell (SCF)
*	807-3365	Module, Ignition Spark, Honeywell (SCFC)
*	807-3551	Transformer, Electronic Ignition (SCF)
		<b>Pilot Ignition Components</b>
22		Pilot Burner
	106-0849SP	Non-CE Natural Gas ( <i>includes burner, thermocouple, gas line and bracket</i> )
	806-8689SP	Non-CE Propane (LP) Gas #16 (Orifice only 810-2400)
	812-1286	CE Natural Gas (G20/G25)
	812-1287	CE LP (G30/G31)
23	807-3550	Thermocouple, Non-CE (SCF; <b>use 812-1284 for CE Thermocouple</b> )
*	807-3485	Thermopile, Non-CE (SCFC)
*	810-0703	Gas Line, 1/4-inch x 17 1/2-inch
*	200-1416	Bracket, Pilot Support
		<b>Piezo Ignitor Components (CE Units only)</b>
*	810-1001	Trigger
*	807-3540	Electrode
*	200-1868	Bracket
*	807-3650	Lead, Trigger to Electrode

\*Not illustrated.

24G SERIES FLATBOTTOM GAS FRYERS  
CHAPTER 2: PARTS LIST

2.3 Flue Caps, Top Caps, and Related Components

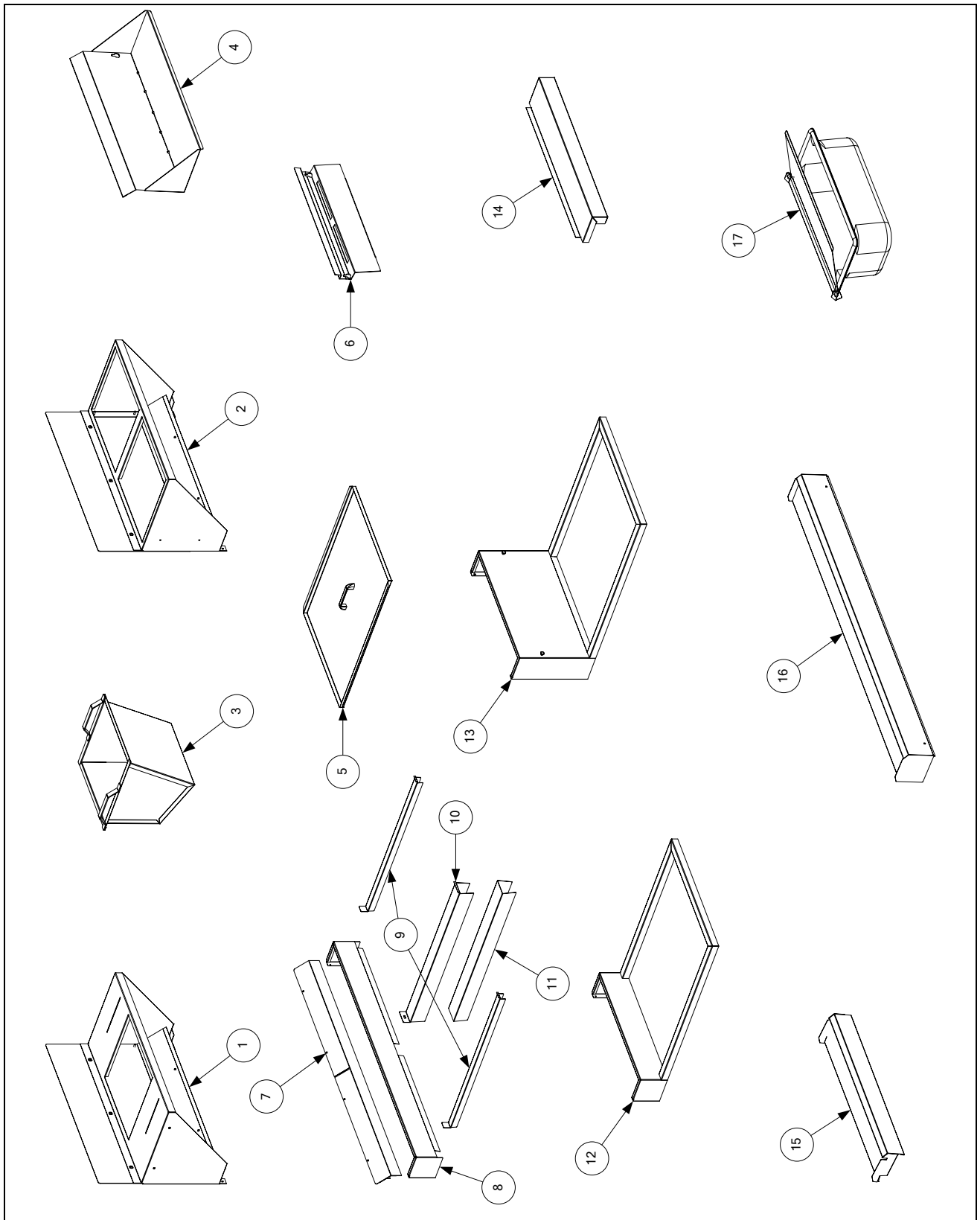



**24G SERIES FLATBOTTOM GAS FRYERS  
CHAPTER 2: PARTS LIST**

**2.3 Flue Caps, Top Caps, and Related Components (cont.)**

ITEM	PART #	COMPONENT
1	106-3253SP	Frame, Single Crumb Dump
2	106-1638SP	Frame, Double Crumb Dump
3	823-4125	Insert, Pan Crumb Dump ½ Size
4	823-4127	Tray, 12424 Single
5	106-2840SP	Cover, 1824G Frypot ( <i>use 106-2839SP for 2424G Frypot</i> )
6	210-6177	Basket Hanger
7		Deflector, Flue Cap Oil
	823-3579	For use on 1824G One-Piece Top Assembly ( <i>use 823-3474 for 2424G</i> )
	210-8244	For use on 1-1824G Fryer ( <i>use 823-210-8171 for 2424G</i> )
	210-8247	For use on 2-1824G with Crumb Dump
	210-8248	For use on 2-2424G with Crumb Dump
	210-8251	For use on 3-2424G with Crumb Dump
	210-8245	For use on 18L/24R with Crumb Dump
	210-8246	For use on 18R/24L with Crumb Dump
	210-8250	For use on 2-24L/18R with Crumb Dump
	210-8249	For use on 2-24R/18L with Crumb Dump
8		Flue Cap
	823-4907	For use on 1-1824G ( <i>use 210-7097 for LJS Short</i> ) ( <i>use 823-4908 for 2424G or 210-7085 for LJS Short</i> )
	823-4911	For use on 2-1824G ( <i>use 823-4912 for 2424G</i> )
	823-4915	For use on 3-2424G (3-Vat 2424G)
	823-4914	For use on 2-24/18R (3-Vat 24/18 System)
	823-4913	For use on 2-24/18L (3-Vat 24/18 System)
	823-4910	For use on 24L/18R 4-Vat 24/18 System
	823-4909	For use on 24R/18L 4-Vat 24/18 System
	823-6881	For use on SCFC Models, 2 battery
9	210-4317	Edge Strip, Frypot
10	210-4313	Joiner Strip (joins frypots within a system)
11	210-4598	Joiner Strip (joins one fryer system to another)
12	823-3622	Top Assembly, One-Piece Short Flue 1824G ( <i>use 106-1619SP for 2424G</i> ) 3.83"
13	823-3699	Top Assembly, One-Piece Standard Flue 1824G ( <i>use 823-3264 for 2424G</i> ) 9.94"
14	210-2028	Top Cap, 1-1824G ( <i>use 210-7082 for 2424G</i> )
*	823-6818	Top Cap, SCFC Models, 2 battery
15	823-3807	Marine Edge for 1-1824G with Top Cap ( <i>use 823-3171 for 2424G</i> )
16		Marine Edge (Solid End-Cap)
	823-4136	1-1824G Without Notches ( <i>use 823-4135 for FM emboss 2424G, or 823-4917 for DEAN emboss</i> )
	823-4137	2-2424G Without Notches
	823-4054	2-2424G Notched Left End ( <i>use 823-4058 for notched right end</i> )
	823-4139	3-2424G Without Notches
	823-4150	3-2424G Notched Left End ( <i>use 823-4151 for notched right end</i> )
	823-4152	2-24/18L 3-Vat Fryer Without Notches
	823-4056	24L/18R 4-Vat Fryer Notched Left End ( <i>use 823-4157 for notched right end</i> )
	823-6789	SCFC Models, 2 battery
17	823-3542	Pan, Batter ½ with Lid
*	803-0209	Brush, Frypot Cleaning
*	803-0293	Gloves, Neoprene Hot Oil

\* Not illustrated.

24G SERIES FLATBOTTOM GAS FRYERS  
CHAPTER 2: PARTS LIST

2.4 Common Cabinet Components (SCFC Models)

2.4.1 Cabinetry – SCFC Models

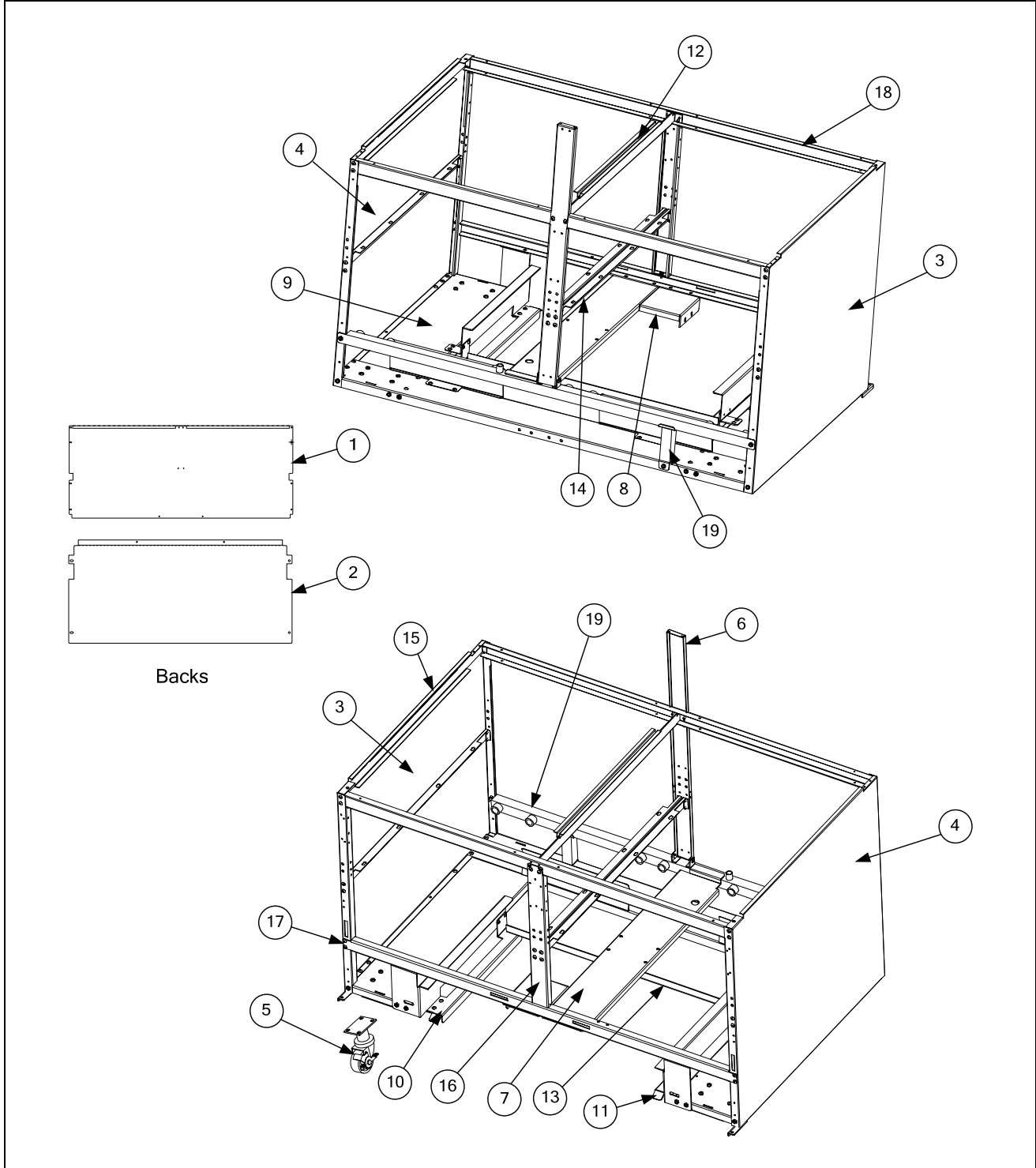

**24G SERIES FLATBOTTOM GAS FRYERS  
CHAPTER 2: PARTS LIST**

**2.4.1 Cabinetry – SCFC Models (cont.)**

<b>ITEM</b>	<b>PART #</b>	<b>COMPONENT</b>
1	220-4752	Back, Upper Cabinet
2	220-0365	Back, Lower Cabinet
3		Panel, Left Side
	231-0395	Stainless Steel Cabinet
	221-1456	Painted and Cold Rolled Steel Cabinet
4		Panel, Right Side
	232-0395	Stainless Steel Cabinet
	222-1456	Painted and Cold Rolled Steel Cabinet
*	200-1471	Door, Access Duct
5	810-0357	Caster, 5-inch with Brake Swivel (4-hole pattern)
*	810-0356	Caster, 5-inch without Brake Swivel (4-hole patter)
6		Post, Rear Cabinet
	220-4775	Stainless Steel or Painted
	220-0404	Cold Rolled Steel
7	220-3537	Bridge, Filter Pump
8	220-3790	Support, Filter Pump Motor
9	106-5788	Base, Filter
10	222-0980	Guide, Filter Pan, Left
11	221-0980	Guide, Filter Pan, Right
12	220-0760	Divider, Frypot
13	220-4149	Stop, Drain Pan
14	220-0762	Brace, Firebox
15	220-0761	Brace, Frypot
16	220-0369	Post, Front Cabinet
17	200-9231	Brace, Front Cabinet
18	200-9229	Brace, Top Cabinet
19	810-3088	Oil Return Manifold ( <i>Sect. 2.6.2, Item 13 attaches here</i> )

\* Not illustrated.

**24G SERIES FLATBOTTOM GAS FRYERS  
CHAPTER 2: PARTS LIST**

**2.4.2 Door Assemblies and Component Parts – SCFC Models**

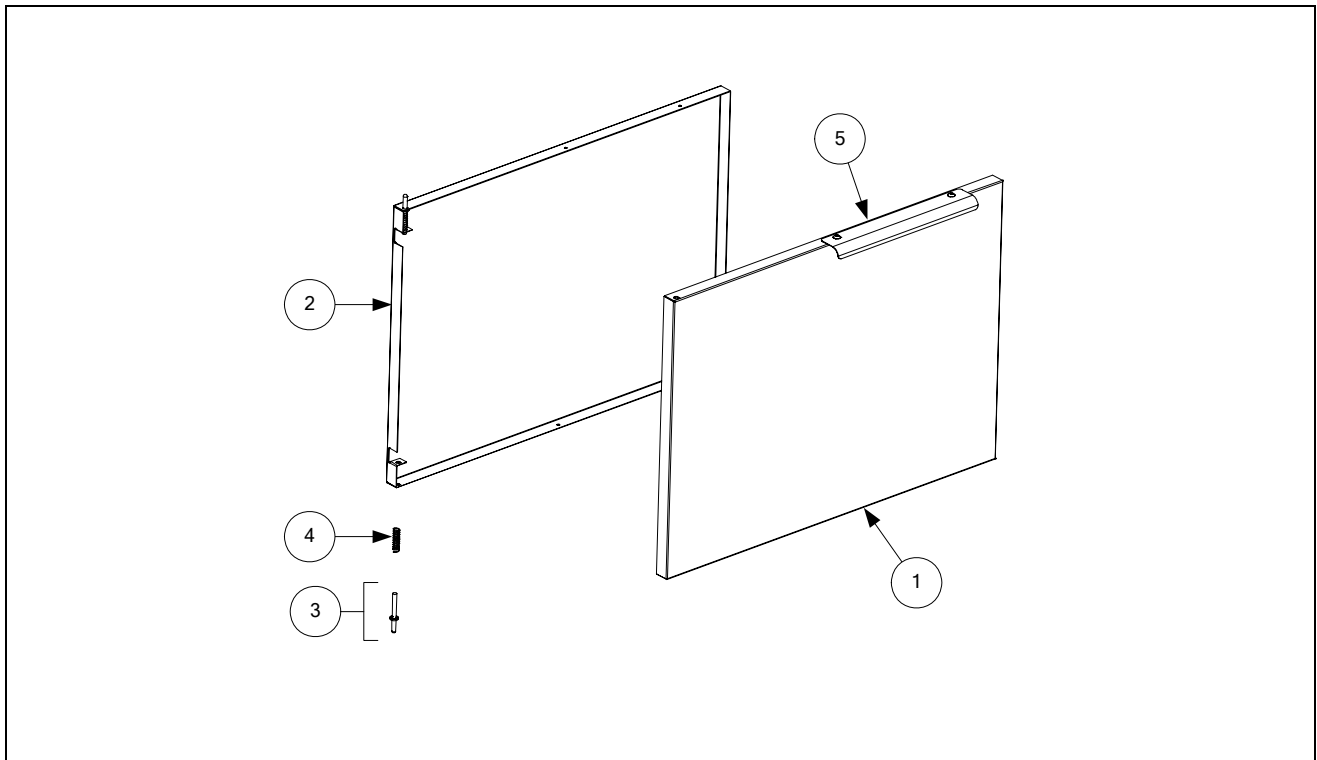

ITEM	PART #	COMPONENT
1	824-1912	Panel, Door
2	220-4128	Liner, Door
3	106-4067	Pin Assembly
4	810-0275	Spring
5	210-8077	Handle

# 24G SERIES FLATBOTTOM GAS FRYERS

## CHAPTER 2: PARTS LIST

### 2.4.3 Control Panels, Wireways, and Related Components – SCFC Models

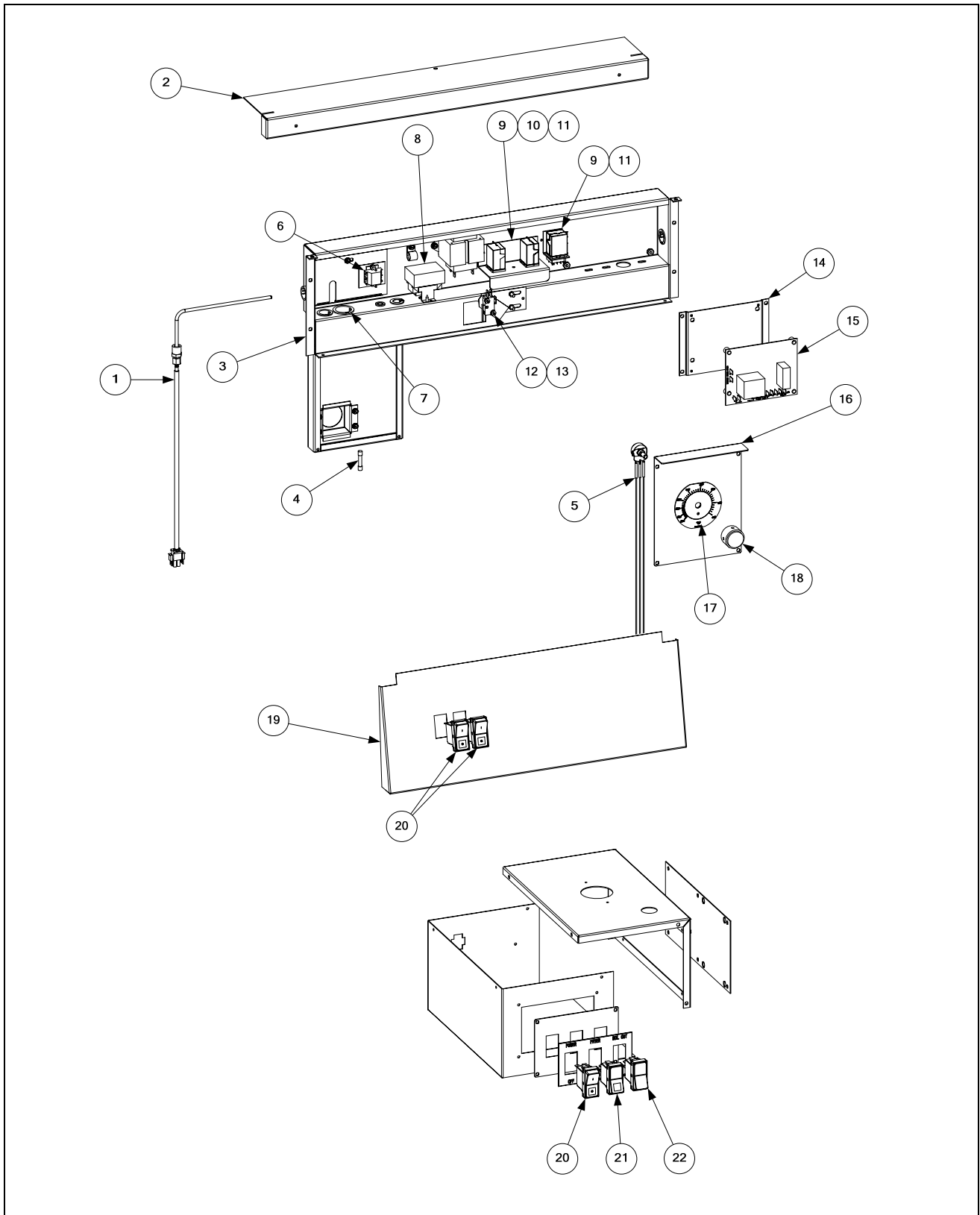

**24G SERIES FLATBOTTOM GAS FRYERS  
CHAPTER 2: PARTS LIST**

**2.4.3 Control Panels, Wireways, and Related Components – SCFC Models (cont.)**

ITEM	PART #	COMPONENT
1	106-2607SP	Probe, 1824G/2424G, 20" Leads
2	220-0843	Vent, 1824G Wireway
3	823-5765	Box, 1824G Wireway
*	200-9812	Cover, Component Box
4	807-3843	Fuse, 3-amp Buss
5	807-3536	Potentiometer, Temperature Control with spade terminals
6	816-0217	Paper, Terminal Block Insulating
7	807-2469	Bushing, 1-inch
8	807-3559	Thermostat, 435°F High-Limit w/Manual Reset
*	200-9681	Support, High-Limit Thermostat
9	807-4114	Relay, Latch/Filter 24VAC Coil
10	807-3922	Relay, Boil Out 12VDC
*	220-3769	Bracket, Relay
11	810-2747	Spring, Relay Hold Down
12	816-0220	Insulation, Microswitch
13	807-2103	Microswitch, Straight Lever
14	200-4719	Plate, Interface Board Mounting
15	106-3729	Thermatron Board, 24V, Extended Melt Cycle
16	106-3306	Thermatron Faceplate Assembly
17	230-1282	Faceplate, 1824G Thermatron Blank
18	802-2050	Label, Thermatron Faceplate
19	810-0110	Knob, Thermatron Control
20	106-5875	Control Panel, 1824G Two-Switch
21	807-3574	Switch, Power ON/OFF Rocker
22	807-3576	Switch, Momentary Reset
22	807-3575	Plug, Rocker Switch Hole

\* Not illustrated.

# 24G SERIES FLATBOTTOM GAS FRYERS CHAPTER 2: PARTS LIST

## 2.4.4 Oil Return and Suction Manifolds – SCFC Models

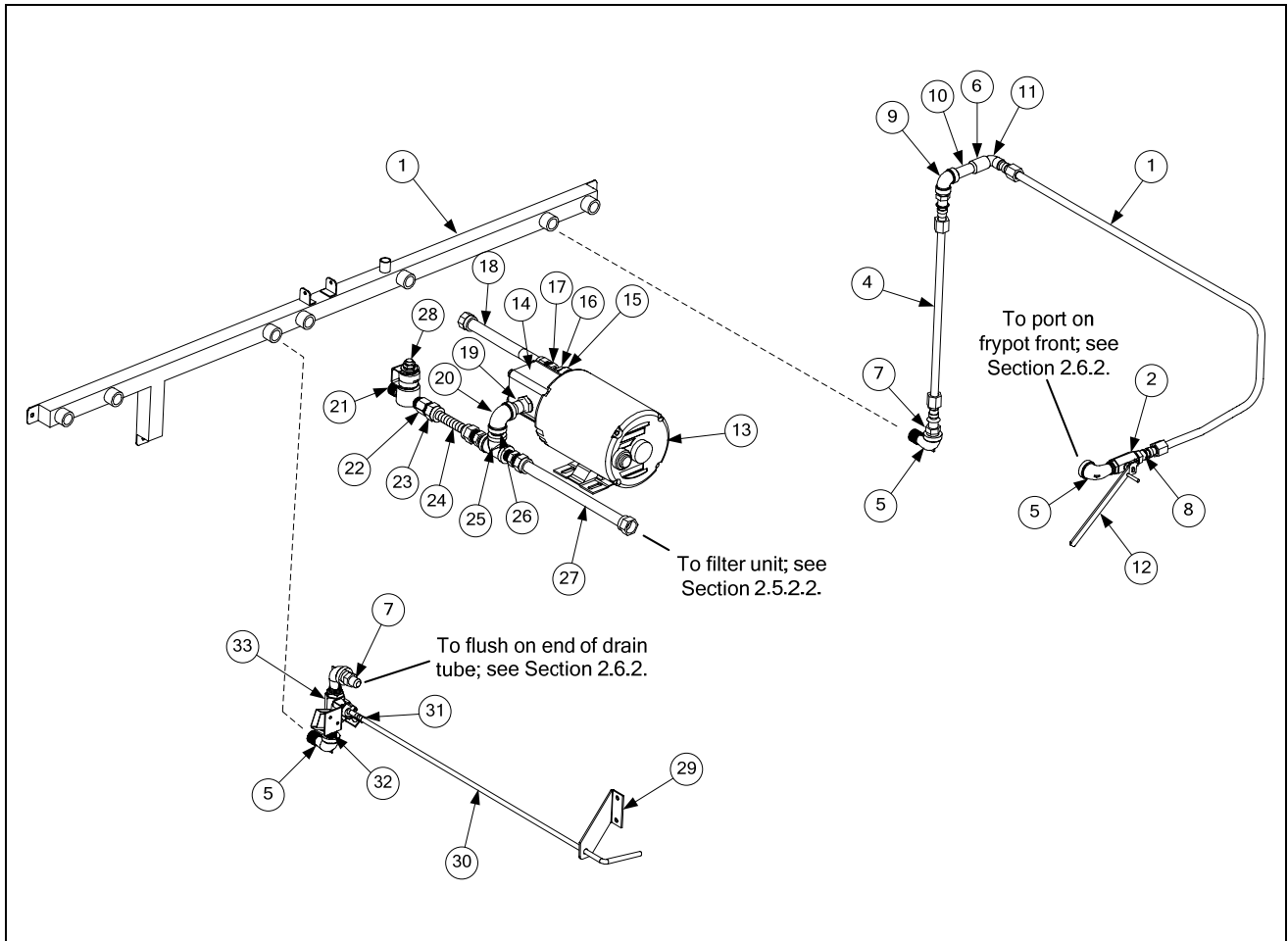

**24G SERIES FLATBOTTOM GAS FRYERS  
CHAPTER 2: PARTS LIST**

**2.4.4 Oil Return and Suction Manifolds – SCFC Models (cont.)**

ITEM	PART #	COMPONENT
1	810-3088	Oil Return Manifold
	106-5461	Oil Return Plumbing
2	810-2125	Drain Valve, 3/8" Ball Valve
3	810-3011	Tubing, Drain Valve, Front
4	810-3014	Tubing, Oil Return, Rear
5	813-0165	Elbow, Street, 1/2" x 1/2" NPT, 90°
6	813-0462	Coupling, 3/8"
7	813-0613	Flare Fitting, 1/2-37° x 1/2"
8	813-0614	Flare Fitting, 1/2-37° x 3/8"
9	813-0631	Elbow, 3/8" x 90°
10	813-0649	Nipple, Black Tube, 3/8" NPT x 2.5"
11	813-0894	Elbow, 3/8" NPT x 1/2-37° Flare
12	823-5815	Oil Return Handle
		Pump and Motor
13	810-3347	Pump, Viking 8 GPM
*	810-2716	Pump, 2-piece, 4GPM
14	826-1712	Motor, 115V 60Hz ( <i>gasket included</i> )
*	826-1270	Motor, 230V 50/60Hz ( <i>gasket included</i> )
*	816-0093	Gasket, Pump/Motor ( <i>included with motor</i> )
15	813-0168	Elbow, 3/4" x 3/4" NPT, Street, 90°
16	813-0031	Bushing, Hex, 3/4" NPT x 1/2"
17	810-1668	Adapter, Male, 5/8" OD x 1/2"
18	810-1067	Flexline, 5/8" OD x 8.5" long
19	813-0298	Nipple, 1/2" x 2.0" NPT
20	813-0062	Elbow, 1/2", 90°
21	813-0304	Bushing, 1/2" x 1/4", Flush
22	813-0838	Nipple, 1/4" NPT, Close
23	810-1669	Adapter, Female, 7/8" OD x 1/2"
24	810-1339	Flexline, 5/8" OD x 4.5" long
25	813-0003	Tee, 1/2" x 1/2" x 1/2"
26	813-0022	Nipple, 1/2" x Close NPT
27	810-1055	Flexline, 5/8" OD x 11.5" long
*	823-5740	Oil-return Suction tube, female
28	106-3470SP	Valve, Solenoid, Female Pins
*	813-0265	Nipple, 1/2" x 2.5" NPT
*	807-2304	Heater Strip, 72", 120V/100W, Silicone
*	806-5934SP	Heater Tape, 18", 240V/25W
29	220-0965	Mount, Handle, Drain Flush
30	220-0973	Handle, Drain Flush
31	809-0601	Clevis Clip
32	813-0087	Nipple, 1/2" x 1.50" NPT
33	106-4006	Valve, Flush

\* Not illustrated.



**24G SERIES FLATBOTTOM GAS FRYERS  
CHAPTER 2: PARTS LIST**

**2.4.5 Filter Unit – SCFC Models**

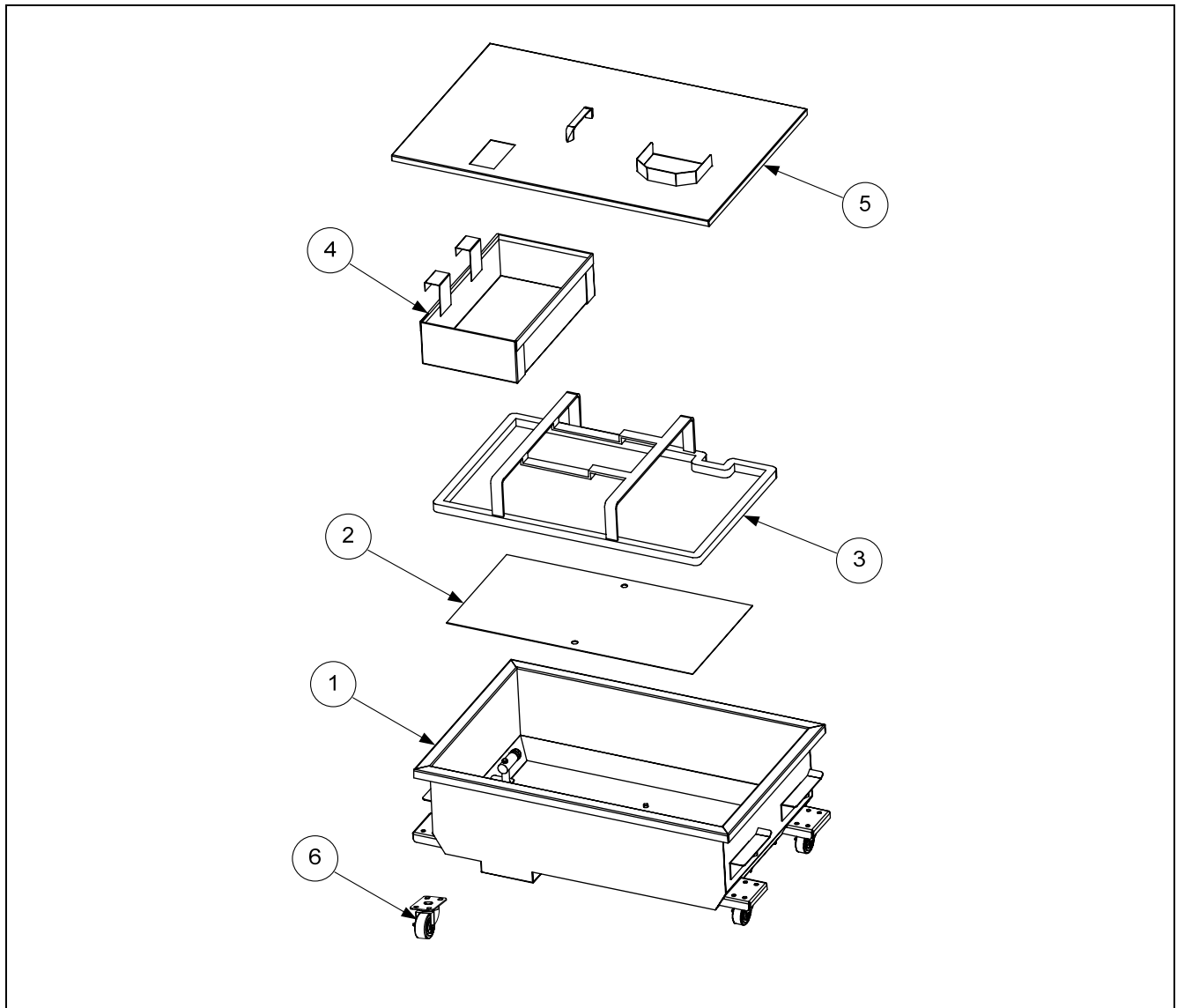

ITEM	PART #	COMPONENT
1	106-8465SP	Filter Pan (with 2" casters)
2	220-1145	Screen
3	810-3082	Hold Down Ring
4	823-5833	Crumb Basket
5	106-6131	Lid, Filter Pan
6	810-2805	Caster, 2"
*	816-0596	O-rings (for filter pan pick up tube)
*	803-0342	Filter Powder, 25-pack
*	803-0289	Filter Paper, 24" x 34"
*	810-2800	Filter Leaf (for common cabinet filter pan)
*	816-0757	O-rings (for filter leaf)

\* Not illustrated.

24G SERIES FLATBOTTOM GAS FRYERS  
CHAPTER 2: PARTS LIST

2.4.6 Frypot, Drain, and Oil Return Components – SCFC Models

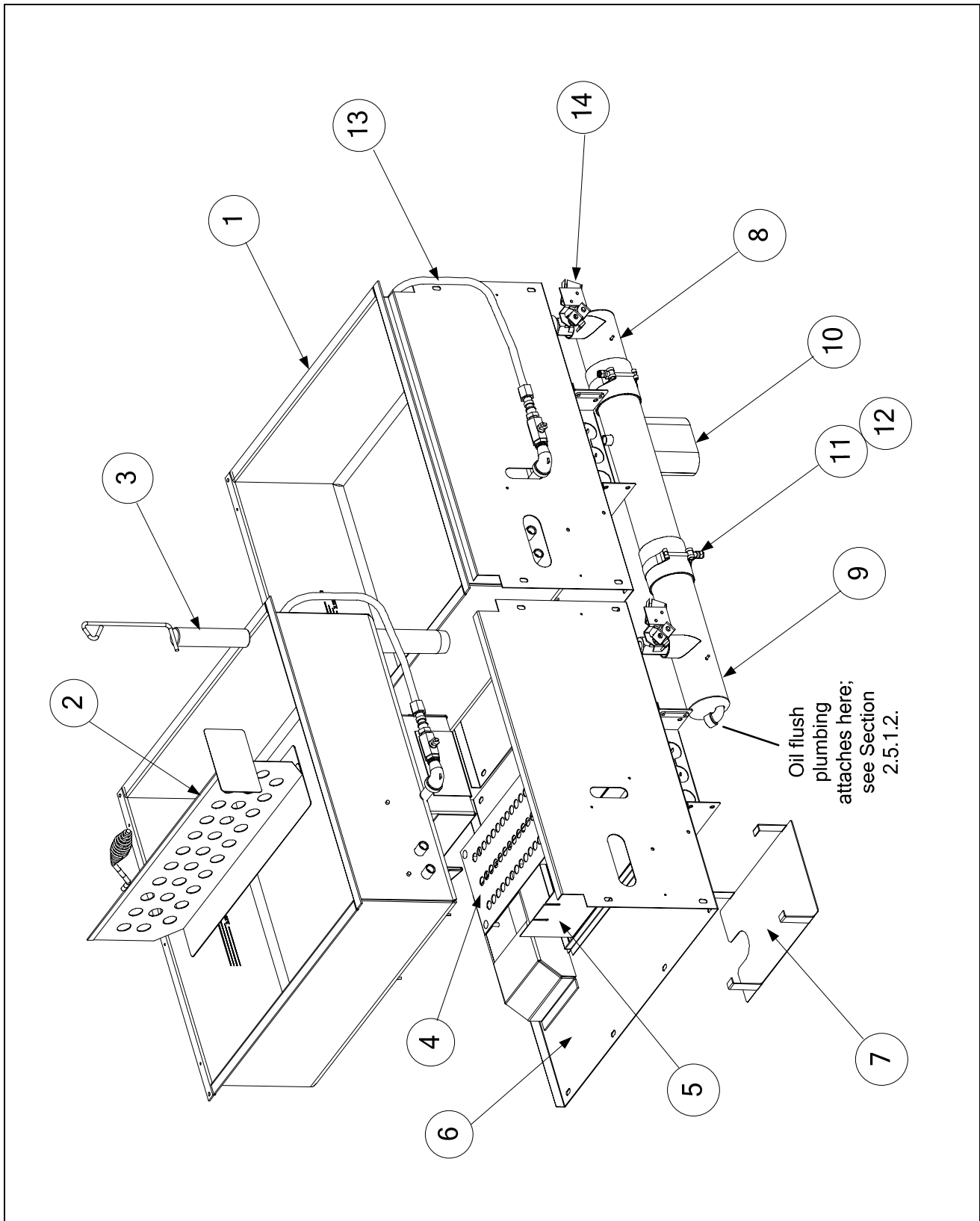

**24G SERIES FLATBOTTOM GAS FRYERS  
CHAPTER 2: PARTS LIST**

**2.4.6 Frypot, Drain, and Oil Return Components – SCFC Models (cont.)**

ITEM	PART #	COMPONENT
1	826-1821	Frypot Kit, 1824G (Front Drain, Front Return) <i>(use 826-1821 for 2424G)</i>
2	823-3934	Divider, Frypot
3	823-3174	Plug, Frypot Drain
4	823-3190	Baffle, Secondary Air
5	210-1409	Spreader, Side Flame
6	823-4062	Firebox Assembly
*	826-2036	Insulation, Pot FB
7	220-3512	Guard, Firebox, Bottom
8	812-1822	Tube, Drain, RH
9	812-1823	Tube, Drain, LH
10	812-2017	Tube, Drain, Center Dump
11	816-0729	Sleeve, Drain Tube Connector
12	809-0969	Clamp, 3" T-bolt
13	106-5461	Oil Return Plumbing <i>(attaches to Section 2.3.1.2, Item 19 at the back of the unit)</i>
	810-2125	Drain Valve, 3/8-inch Bal Valve
	810-3011	Tubing, Front
	810-3014	Tubing, Rear
	813-0165	Elbow, 1/2" x 1/2" Street, 90°
	813-0462	Coupling, 3/8-inch
	813-0613	Fitting, 1/2-inch x 1/2-inch 37° Flare
	813-0614	Fitting, 1/2-inch x 3/8-inch 37° Flare
	813-0631	Elbow, 3/8-inch x 90°
	813-0649	Nipple, 3/8-inch NPT x 2.50 inch
	813-0894	Elbow, 1/2-inch x 3/8-inch 37° Flare
14	106-4006	Drain Valve with Microswitch, 1/2"
*	816-0211	Sleeve, Red Valve Handle
*	807-2104	Microswitch, Drain Valve Roller Lever <i>(use 902-2348 for M/S Guard)</i>
*	813-1790	Nipple, 1 1/4-inch x 5.85 inch NPT Toe
*	813-0165	Elbow, 1/2-inch x 90° NPT Street
*	813-0632	Elbow, 3/8-inch x 90° NPT Street
*	810-2125	Valve, 3/8-inch Oil Return Ball <i>(use 200-1143 for Nut Retainer)</i>
*	823-5815	Handle, UFF Oil Return
*	816-0548	Cap, Yellow Vinyl Oil Return Handle
*	810-3014	Tube, Front Oil Return
*	200-4725	Guard, Probe and High-Limit
*	210-1433	Clamp, Probe and High-Limit Bulb
*	200-4505	Plate, Drain Nipple Closure
*	812-1515	Nipple, 3/8-inch x 2.345-inch NPT Toe

\* Not illustrated.

24G SERIES FLATBOTTOM GAS FRYERS  
CHAPTER 2: PARTS LIST

2.5 Previous Style SCF Models

2.5.1 Cabinetry – SCF Models

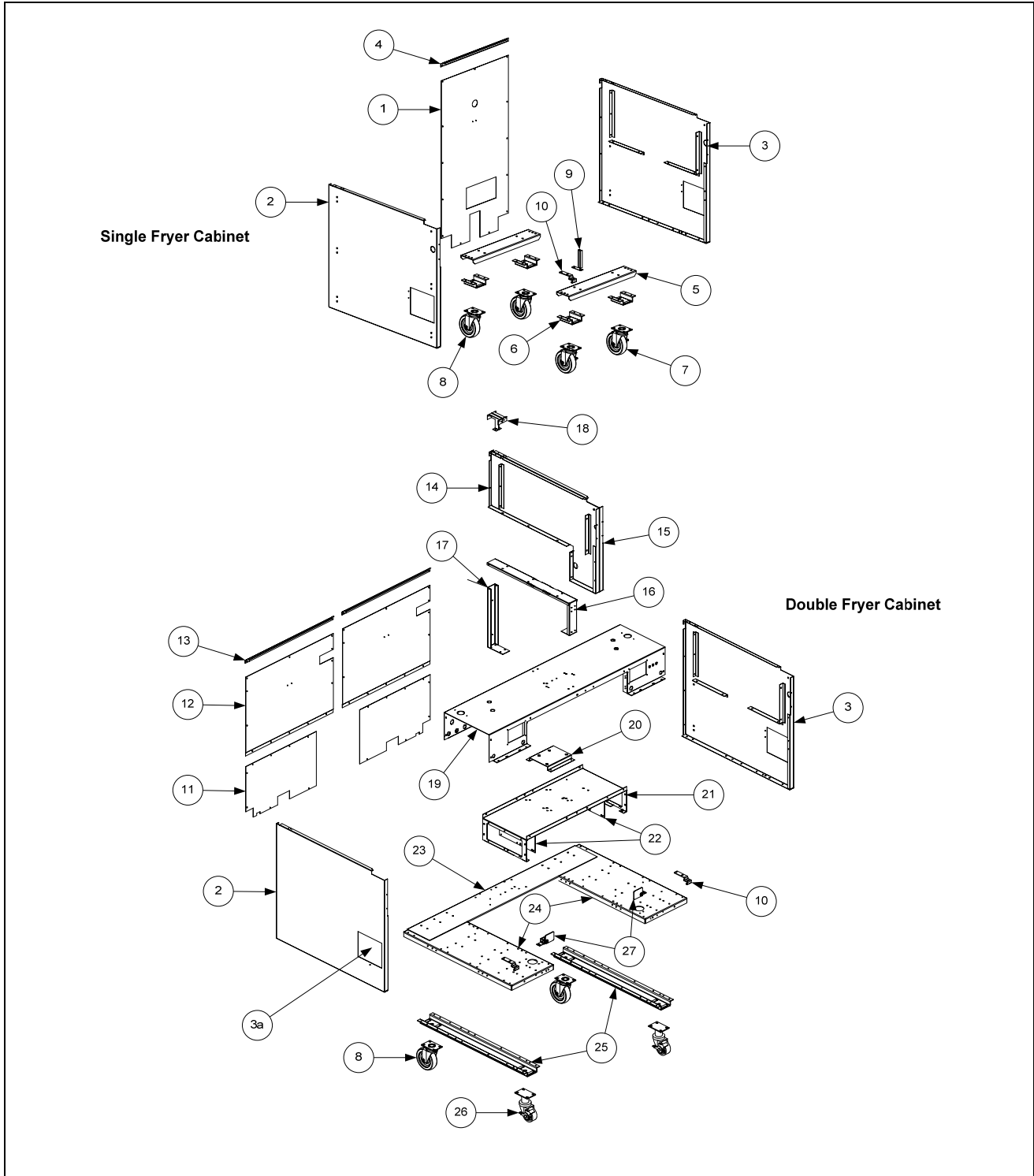

**24G SERIES FLATBOTTOM GAS FRYERS  
CHAPTER 2: PARTS LIST**

**2.5.1 Cabinetry – SCF Models (cont.)**

<b>ITEM</b>	<b>PART #</b>	<b>COMPONENT</b>
1		Back, Single Fryer Cabinet
	200-1608	Standard 1824G ( <i>for 2424G, use 200-1500</i> )
	210-3006	Short Flue 1824G ( <i>for 2424G, use 200-2005</i> )
2		Panel, Left Side
	823-3459	Stainless Steel Cabinet
	823-4349	Painted Steel Cabinet
3		Panel, Right Side
	823-3489	Stainless Steel Cabinet
	823-4350	Painted Steel Cabinet
3a	210-2977	Cover, Side Panel Access
4	210-1534	Rail, 1824G Cabinet Back Support ( <i>for 2424G, use Item 13</i> ) <i>older units</i>
5	200-2903	Channel, 1824G Front and Rear Base
6	823-4063	Support, Caster
7		Caster, 5-inch with Brake Swivel
	810-0357	4-Hole Bolt Pattern
	810-2405	Single Stud
8		Caster, 5-inch without Brake Swivel
	810-0356	4-Hole Bolt Pattern ( <i>for fryers with legs in front, use 810-0378 Rigid Caster</i> )
	810-2406	Single Stud
*	810-2053	Leg, 6-inch Adjustable
*	826-1468	Kit, Shim Caster ( <i>contains 8 shims</i> )
*	900-2949	Shims, Caster 14 gauge
9	200-1378	Bracket, Drain Nipple Storage
10	200-4511	Hinge, Universal Door ( <i>for filter-ready units, use 200-1675</i> )
11		Back, Lower Cabinet
	200-4154	Units with Built-in Filtration
	200-4153	1824G Units without Built-in Filtration ( <i>for 2424G, use 200-4152</i> )
12	200-4151	Back, 1824G Upper Cabinet ( <i>for 2424G, use 200-4150</i> )
*	200-1607	Back, 2424G One-Piece ( <i>used on UFF units built before February 2003 only</i> )
13	210-1406	Rail, 2424G Cabinet Back Support ( <i>for 1824G, use Item 4</i> ) <i>older units</i>
14	823-3581	Panel, Inner Cabinet (Left)
15	823-3582	Panel, Inner Cabinet (Right)
16	200-2632	Support, Inner Cabinet Panel Front
17	200-2624	Upright, Cabinet Rear
18	823-4149	Support, Flue
19	200-5210	Bridge, Filter Base
20	200-2717	Support, Filter Pump Motor
21	200-2643	Base, Filter
22	200-3356	Cover, Filter Base
23	200-5209	Brace, 2424G Rear Cross
24	200-4696	Channel, 2424G Left or Right Base
25	823-4064	Channel, Leg/Caster Support
26	810-1365	Caster with Brake, 3-inch Adjustable
27	106-2837SP	Bracket, Filter Retainer

\* Not illustrated.

**24G SERIES FLATBOTTOM GAS FRYERS  
CHAPTER 2: PARTS LIST**

**2.5.2 Door Assemblies and Component Parts – SCF Models**

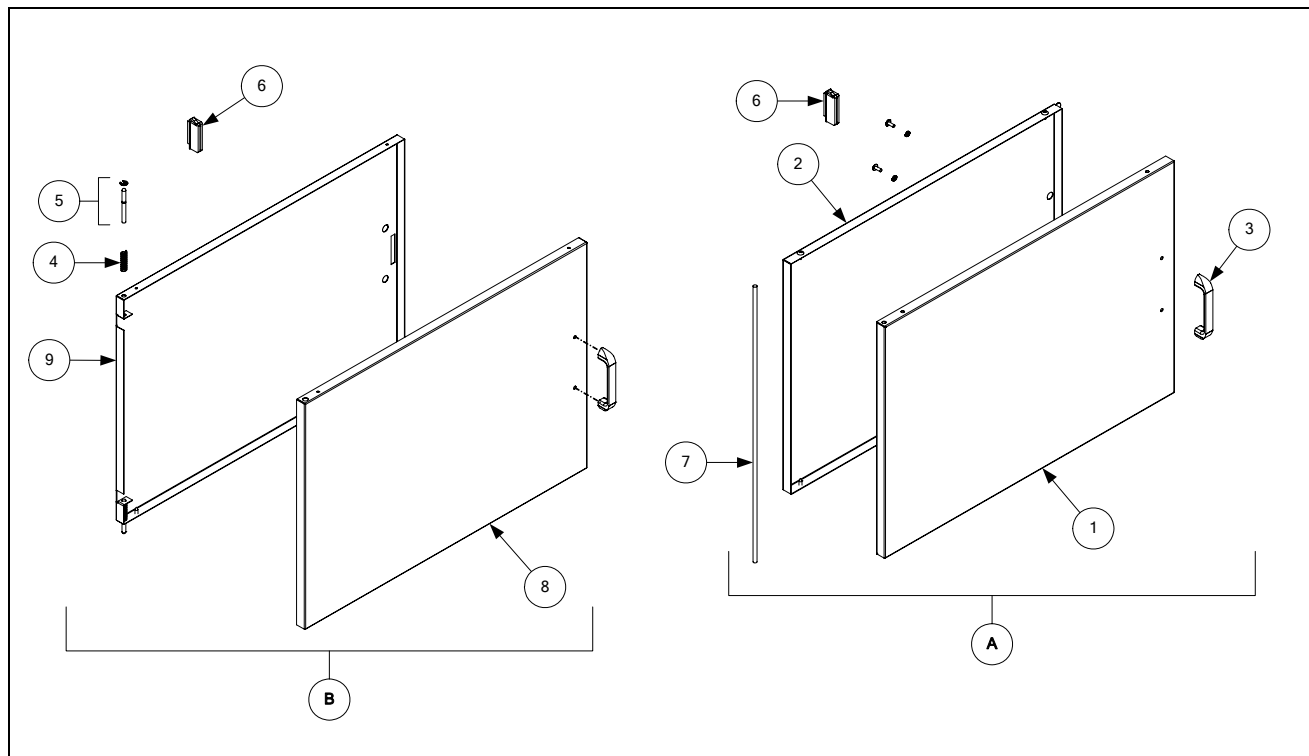

ITEM	PART #	COMPONENT
*	809-0413	Spacer, Nylon (Universal Door Bushing)
A	106-2768	**1824G Single-Pin Door Assembly, 17.80" (for 2424G, use 106-2769)
B	106-2816	1824G Double-Pin Door Assembly (for 2424G, use 106-2782)
1	824-1138SP	Panel, 1824G Single-Pin Outer Door (for 2424G, use 824-1147)
2	200-4548	Panel, 1824G Single-Pin Inner Door (for 2424G, use 200-4549)
3	810-0180	Handle, Door (use 210-9739 for Euro look Handle)
4	826-1343	Spring, Door Hinge (qty. 10)
5	106-4067SP	Hinge Pin and Keeper Assembly, Door
6	810-1105	Magnet, Door
7	200-1301	Hinge Pin, Door
8	824-1146SP	Panel, 1824G Double-Pin Outer Door (for 2424G, use 824-1147SP)
9	200-4610	Panel, 1824G Double-Pin Inner Door (for 2424G, use 200-4546)

\*\* Not illustrated.

\*\* For units without inner door panels (built from 1993-2002), use 106-1751 for 1824G fryers or 106-1649 for 2424G fryers.

# 24G SERIES FLATBOTTOM GAS FRYERS

## CHAPTER 2: PARTS LIST

### 2.5.3 Control Panels, Wireways, and Related Components – SCF Models

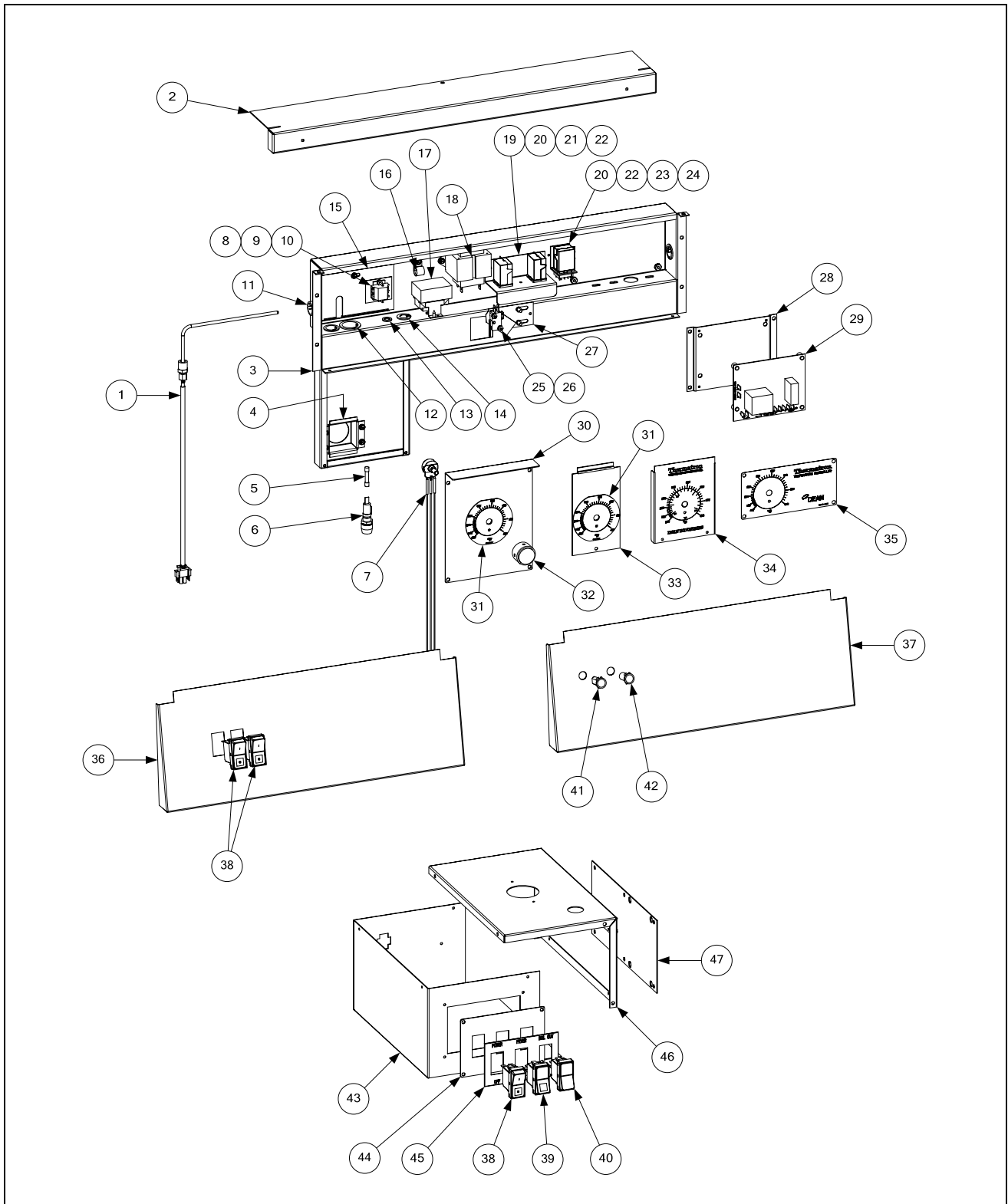

**24G SERIES FLATBOTTOM GAS FRYERS  
CHAPTER 2: PARTS LIST**

**2.5.3 Control Panels, Wireways, and Related Components – SCF Models (cont.)**

ITEM	PART #	COMPONENT
1	106-0882	Probe, Thermostat Assembly, bottom 62.5" with connector ( <i>use 106-2607SP for 20" Top</i> )
2	824-1140	Vent, 1824G Wireway ( <i>use 824-1139 for 2424G</i> )
3	823-4001	Box, 1824G Wireway ( <i>use 823-4000 for 2425G</i> )
4	200-3167	Box, Remote Thermatron Adapter
5	807-1597	Fuse, 3-amp Slow-Blow
6	807-1321	Holder, Panel-Mount Fuse
7	807-3536	Potentiometer, Temperature Control with spade terminals
8	816-0217	Paper, Terminal Block Insulating
9	810-1164	Terminal Block, 1-Piece Screwless
11	810-0045	Bushing, .875-inch
12	807-2469	Bushing, 1-inch
13	810-0678	Bushing, .375-inch
14	807-0125	Bushing, .50-inch
15	200-1671	Cover, Thermostat Entry
16	826-1680	Clamp, Plastic Wire (Pkg. of 8)
17	807-3559	Thermostat, 435°F High-Limit w/Manual Reset ( <i>use 807-3560 for 210°C CE units</i> )
18	807-0800	Transformer, Filter 120V/24V 50/60Hz 50VA
19	106-2058SP	Relay Assembly, Boil-Out and Latch ( <i>use 106-1648SP for Bracket Switch Assembly</i> )
20	807-3611	Relay, Latch/Filter 24VAC Coil (Left Relay) ( <i>use 807-4114 for models after Oct 04</i> )
21	807-3640	Relay, Boil Out 120VAC Coil (Right Relay)
22	807-3613	Spring, Relay Retaining
23	200-1337	Bracket, Oil Return Relay
24	106-1966	Socket Assembly, 24V Oil Return Relay ( <i>use 807-3612 for Relay Socket only</i> )
25	816-0220	Insulation, Microswitch
26	807-2103	Microswitch, Straight Lever
27	106-2775	Plate Assembly, Microswitch Adjustment
28	200-4719	Plate, Interface Board Mounting
29	826-2086	Thermatron Board, 115/230V
30	210-3275	Faceplate, 1824G Thermatron Blank ( <i>use 210-3168 for 2424G</i> )
31	802-2134	Label, Thermatron Faceplate
32	816-0534	Knob, Thermatron Control
33	210-1985	Faceplate, Single Fryer Thermatron Blank
34	820-0136	Faceplate with Label, Old-Style Single Fryer 5.17" H x 4.04" W
35	820-0135	Faceplate with Label, Old-Style SCF 3.13" H x 6.38" W
36	210-3754	Control Panel, 1824G Two-Switch ( <i>use 210-4977 for 2424G</i> )
37	210-2716	Control Panel, 1824G Two-Lamp ( <i>use 210-2652 for 2424G</i> )
38	807-3574	Switch, Power ON/OFF Rocker
39	807-3576	Switch, Momentary Reset
40	807-3580	Switch, Boil-Out
41	106-1978	Lamp Assembly, Red 120V <i>807-3581 lamp only (106-4687 230/250V)(106-4730 24V white)</i>
42	106-4686	Lamp Assembly, Green 120V <i>807-3582 lamp only (106-4686 230/250V)(106-4729 24V)</i>
43	200-4602	Box, Single Fryer Control
44	210-2689	Plate, Single Fryer Control Panel
45	802-2085	Label, Single Fryer Control Panel
46	200-3901	Lid, Single Fryer Control Box
47	200-3356	Cover, Single Fryer Control Box Access
*	807-3577	Circuit Breaker, 7 amp

\* Not illustrated.



# 24G SERIES FLATBOTTOM GAS FRYERS CHAPTER 2: PARTS LIST

## 2.5.4 Oil Return and Suction Manifolds – SCF Models

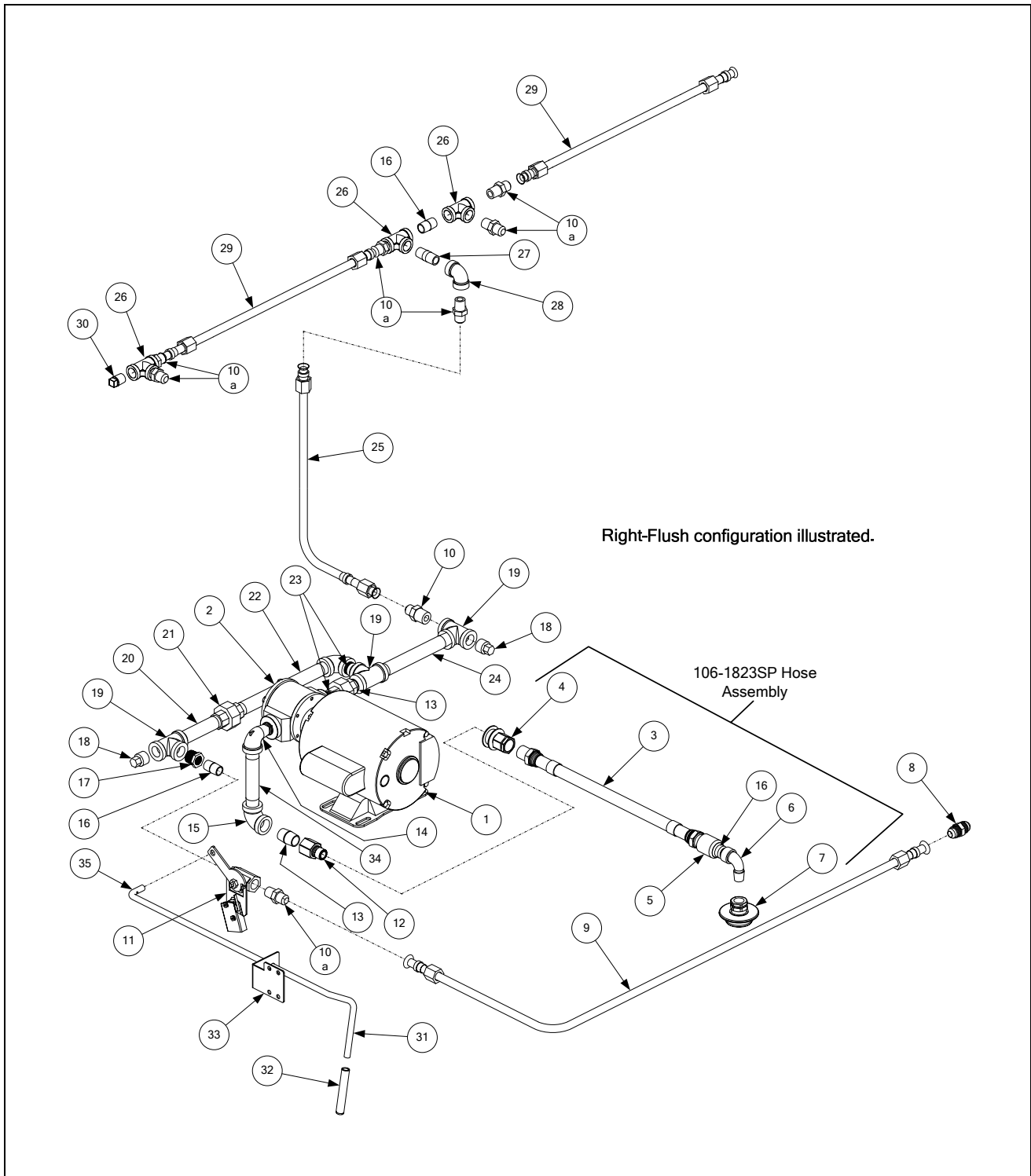

**24G SERIES FLATBOTTOM GAS FRYERS**  
**CHAPTER 2: PARTS LIST**

**2.5.4 Oil Return and Suction Manifolds – SCF Models (cont.)**

ITEM	PART #	COMPONENT
1	810-2100	Motor, 120-230VAC 1/3-HP Filter Pump
2	810-2098	Pump, 8 GPM Filter Haight
3	810-2245	Hose, 16 <sup>3</sup> / <sub>4</sub> " x 1/2" x 1/2" Vacuum Filter Pan to Pump
4	810-2173	Disconnect- Female, 1/2-inch
5	813-0735	Reducer, 1/2-inch to 3/8-inch NPT Bell
6	813-0632	Elbow, 3/8-inch NPT Street
7	810-2762	Disconnect, 3/8-inch Female with Radial Collar
8	810-2562	Coupling, Flare Tubing
9	810-2313	Tubing, Flush (Right-Flush Configurations)
*	810-2307	Tubing, Flush (Left-Flush Configurations)
10	813-0613	Fitting, 1/2-inch x 1/2-inch 37° Flare
10a	813-0614	Fitting, 1/2-inch x 3/8-inch 37° Flare
11	106-3659SP	Flush, Drain Valve Assembly, Complete
	810-2125	Valve, 3/8-inch Flush
	201-6440	Actuator Handle, Flush Valve (Left-Oriented Flush Valves Only) <sup>†</sup>
	200-6202	Actuator Handle, Flush Valve (Right-Oriented Flush Valves Only) <sup>†</sup>
	106-3604	Bracket Assembly, Microswitch Left Rear Flush ( <i>use 106-3682 for Right</i> )
	807-2103	Microswitch, Straight Lever
	816-0220	Insulation, Microswitch
	901-2348	Cover, Microswitch (Left-Oriented Flush Valves Only) <sup>†</sup>
	902-2348	Cover, Microswitch (Right-Oriented Flush Valves Only) <sup>†</sup>
12	810-2170	Disconnect, 1/2-inch Male Quick
13	813-0087	Nipple, 1/2-inch x 1.50-inch NPT
14	813-0165	Elbow, 1/2-inch x 90° NPT Street
15	813-0062	Elbow, 1/2-inch x 90° NPT
16	813-0625	Nipple, 3/8-inch x Close NPT
17	813-0006	Bushing, 1/2-inch to 3/8-inch NPT Hex
18	813-0156	Plug, 1/2-inch NPT Hex
19	813-0003	Tee, 1/2-inch NPT
20	813-0093	Nipple, 1/2-inch x 4-inch NPT
21	813-0173	Union, 1/2-inch NPT
22	813-0673	Nipple, 1/2-inch x 8.5-inch NPT
23	813-0087	Nipple, 1/2-inch x 1.5-inch NPT
24	813-0833	Nipple, 1/2-inch by 15.5-inch NPT
25	810-2270	Tubing, Filter Pump to Rear Oil Return
26	813-0730	Tee, 3/8-inch NPT
27	813-0644	Nipple, 3/8-inch x 1.5-inch NPT
28	813-0631	Elbow, 3/8-inch x 90° NPT
29		Tubing, Rear Oil Return
	810-2262	Tubing, 19.12"
	810-2308	Tubing, 21.65"
	810-2528	Tubing, 21.95"

\* Not illustrated.

**24G SERIES FLATBOTTOM GAS FRYERS  
CHAPTER 2: PARTS LIST**

---

**2.5.4 Oil Return and Suction Manifolds – SCF Models (cont.)**

ITEM	PART #	COMPONENT
	810-2691	Tubing, 56.27"
	810-2692	Tubing, 73.41"
30	813-0452	Plug, 3/8-inch NPT Pipe
31	823-4547	Handle, Drain Flush W/A
32	816-0549	Sleeve, Blue Vinyl (Drain Flush Handle Cover)
33	200-6135	Bracket, Flush Handle (Mounts to Inner Panel)
34	813-0251	Nipple, 1/2-inch by 4.5-inch NPT
35	809-0843	Cotter Pin

\* Not illustrated.

† Valve stem pointing to left is left-oriented; Valve stem pointing to right is right oriented.

**24G SERIES FLATBOTTOM GAS FRYERS  
CHAPTER 2: PARTS LIST**

**2.5.5 Filter Unit – SCF Models**

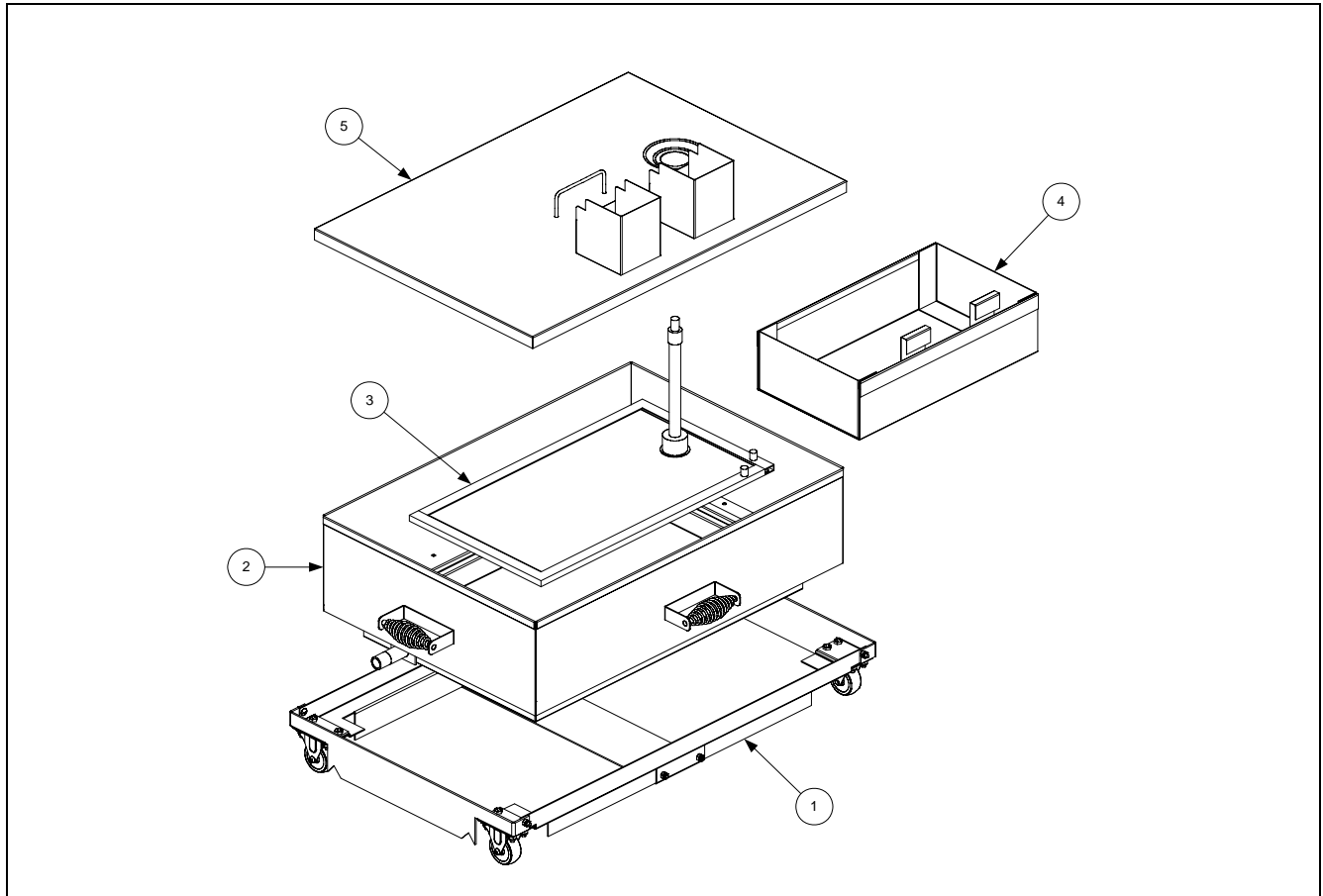

ITEM	PART #	COMPONENT
1	106-1693SP 810-2807 809-0428 106-1692SP	Filter Pan Caddy Assembly Caster, 2-inch Rigid ( <i>use 810-2805 for 2-inch Swivel Caster</i> ) Bolt, 1/4-20 x 1/2-Inch Hex Head Filter Pan Complete ( <i>incl. Pan, Filter, Leaf, Crumb Basket and Lid; does not include item #1</i> ).
2	823-3480SP	Filter Pan (with fittings)
3	106-3675SP 810-2700 813-0867 810-2760	Filter Leaf, 11" x 19" (with Compression Cap & Riser Connection) Quick Disconnect, 3/8-inch Male SS Riser Standpipe Nipple, 3/8-inch x 6.5-inch S/S Compression Cap with 3/8-inch NPT threads
4	823-3509	Crumb Basket
5	823-3492	Lid Assembly, Filter Pan
*	803-0002	Powder, Filter 80 Individual Packs
*	810-2759	Filter Screen Assembly only without standpipe parts.

\* Not illustrated.

## 24G SERIES FLATBOTTOM GAS FRYERS CHAPTER 2: PARTS LIST

### 2.5.6 Frypot, Drain, and Oil Return Components – SCF Models

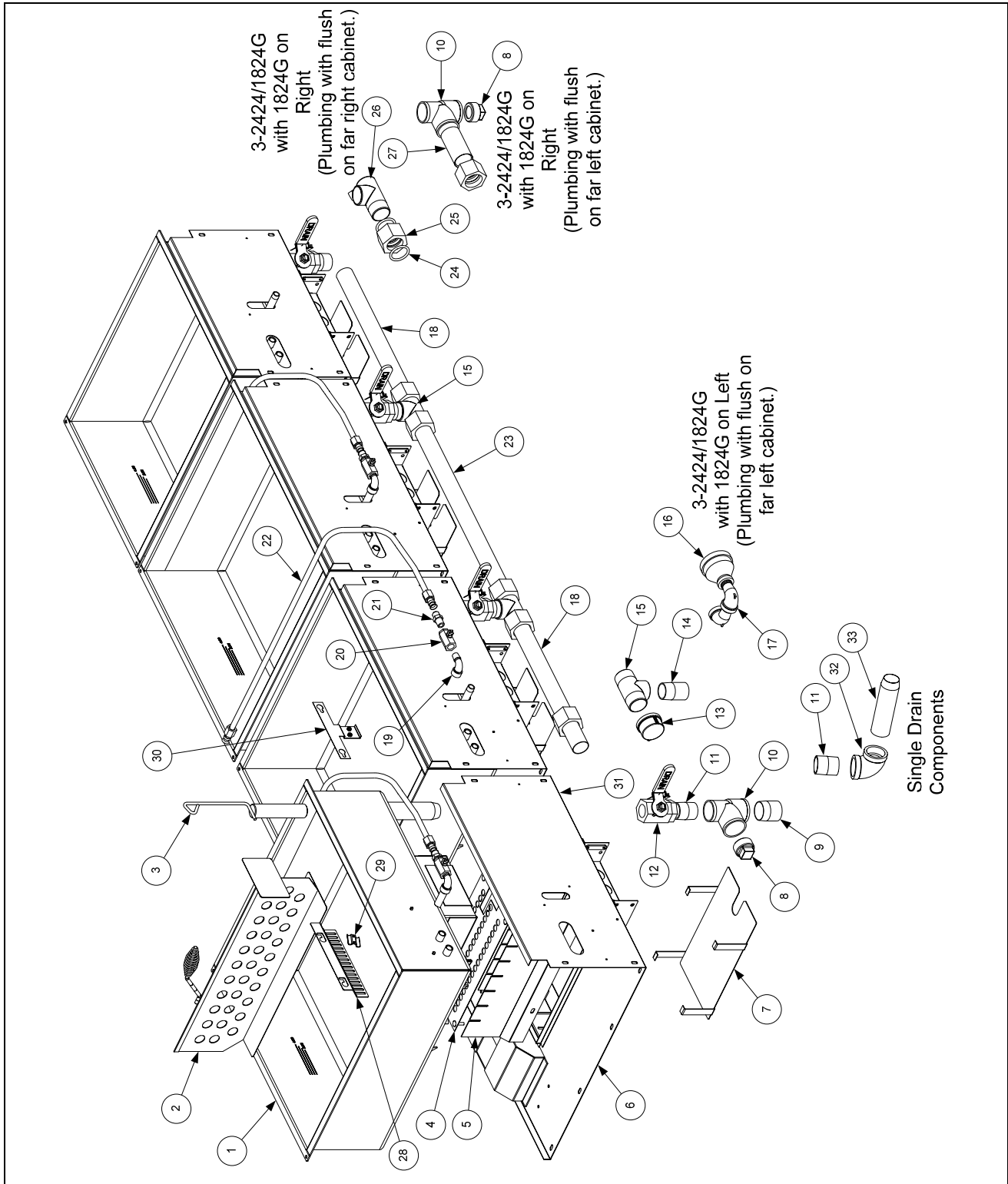

**24G SERIES FLATBOTTOM GAS FRYERS  
CHAPTER 2: PARTS LIST**

**2.5.6 Frypot, Drain, and Oil Return Components – SCF Models (cont.)**

ITEM	PART #	COMPONENT
1	826-1823	Frypot Kit, 1824G (Front Drain, Front Return) <i>(use 826-1821 for 2424G)</i>
*	826-1822	Frypot Kit, 1824G (Front Drain, w/o Filtration) <i>(use 826-1820 for 2424G)</i>
*	826-1828	Frypot Kit, 1824G (Rear Drain, Front Return) <i>(use 826-1842 for 2424G)</i>
2	823-3934	Divider, Frypot
3	823-3174	Plug, Frypot Drain
4	823-3190	Baffle, Secondary Air
5	210-1409	Spreader, Side Flame
6	823-3504	Firebox Assembly, 1824G <i>(use 823-4062 for 2424G)</i>
*	826-2036	Insulation, Pot FB
*	KIT5505SP	Kit, 1824G Firebox Insulation <i>(use KIT5507SP for 2424G)</i>
7	823-3170	Guard, Firebox Bottom
8	813-0868	Plug, 1½-inch NPT Pipe
9	813-0732	Nipple, 1½-inch x 2-inch NPT Toe
10	813-0765	Tee, 1½-inch x 1¼-inch x 1½-inch <i>(all connections Female)</i>
11	813-0391	Nipple, 1¼-inch x Close NPT <i>(connects drain valve to tee)</i>
12	823-3463	Valve with Microswitch Holder, 1¼-inch Drain <i>(W/A prior to 9/21/04)</i>
	106-5211	Valve with Microswitch Holder, 1¼-inch Drain <i>(W/A after 9/21/04)see pg.2-22</i>
*	814-0047	Sleeve, Red Valve Handle
*	807-2104	Microswitch, Drain Valve Roller Lever <i>(use 902-2348 for M/S Guard)</i>
13	823-3603	Cap, 1½-inch NPT Pipe
14	813-0143	Nipple, 1¼-inch x 2½-inch NPT Toe
15	813-0760	Tee, 1½-inch x 1¼-inch x 1½-inch NPT Drain
16	813-0686	Cap, Drain Flush End (1824G Left)
17	813-0165	Elbow, ½-inch x 90° NPT Street
18	200-6587	Tube, 1⅝-inch x 18½-inch Drain Manifold
19	813-0632	Elbow, ⅜-inch x 90° NPT Street
20	810-2125	Valve, ⅜-inch Oil Return Ball <i>(use 200-1143 for Nut Retainer)</i>
*	823-3465	Handle, UFF Oil Return
*	816-0548	Cap, Yellow Vinyl Oil Return Handle
21	813-0614	Fitting, ½-inch x ⅜-inch 37° Flare
22	810-2556	Tube, Front Oil Return
23	200-1845	Tube, 1⅝-inch x 24½-inch Drain Manifold <i>(use 200-1841 for 20" tube)</i>
24	816-0544	O-Ring
25	809-0884	Nut, Slip-Joint
26	813-0768	Tee, 1824G Right Drain Flush
27	810-2276	Nipple, UFF Drain Line, 1½-inch NPT x 3.69-inch
28	200-4725	Guard, Probe and High-Limit
29	210-1433	Clamp, Probe and High-Limit Bulb
*	810-2164	Spring, Temp Probe
*	809-0102	Screw, Temp Probe Clamp <i>(Two Required)</i>
30	823-4548	Retainer, Probe (used on units without Probe/High-Limit Bulb Clamp)
31	200-4505	Plate, Drain Nipple Closure
32	813-0070	Elbow, 1¼-inch
33	813-0662	Nipple, 1¼-inch x 5¾-inch

\* Not illustrated.

**24G SERIES FLATBOTTOM GAS FRYERS  
CHAPTER 2: PARTS LIST**

**2.6 Drain Valve and Components**

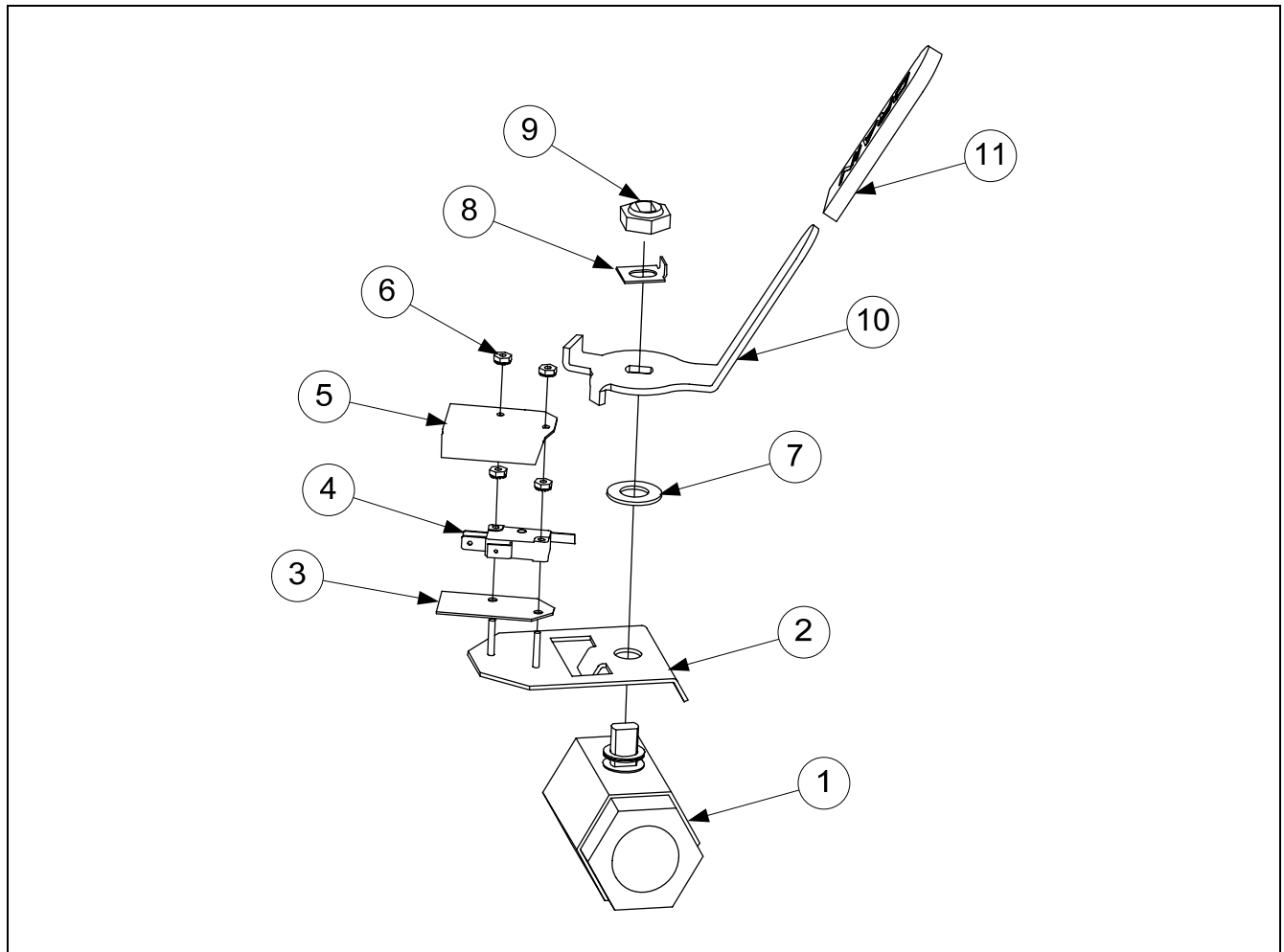

ITEM	PART #	COMPONENT
		Valve Assembly, 18/24 Drain
1	810-2052	Valve, Drain 1 1/4-inch (1-inch Std. Port)
2	106-4526	Bracket Assembly
3	816-0220	Insulation
4	807-2103	Switch, Micro CE Straight Lever
5	902-2348	Cover, Safety Switch
6	826-1366	Nut, 4-40 KEPS Hex (Pkg. of 25)
7	809-0988	Washer, 1.00 OD x .525 ID Teflon
8	900-2936	Retainer, Nut Drain Valve
9	809-0540	Nut, 1/2-inch -13 Two way Hex Lock
10	210-8558	Handle, 2424 Drain Valve
11	816-0211	Sleeve, Plastic 1 1/4-inch Red

**24G SERIES FLATBOTTOM GAS FRYERS  
CHAPTER 2: PARTS LIST**

**2.7 Wiring Connectors, Pin Terminals, and Power Cords**

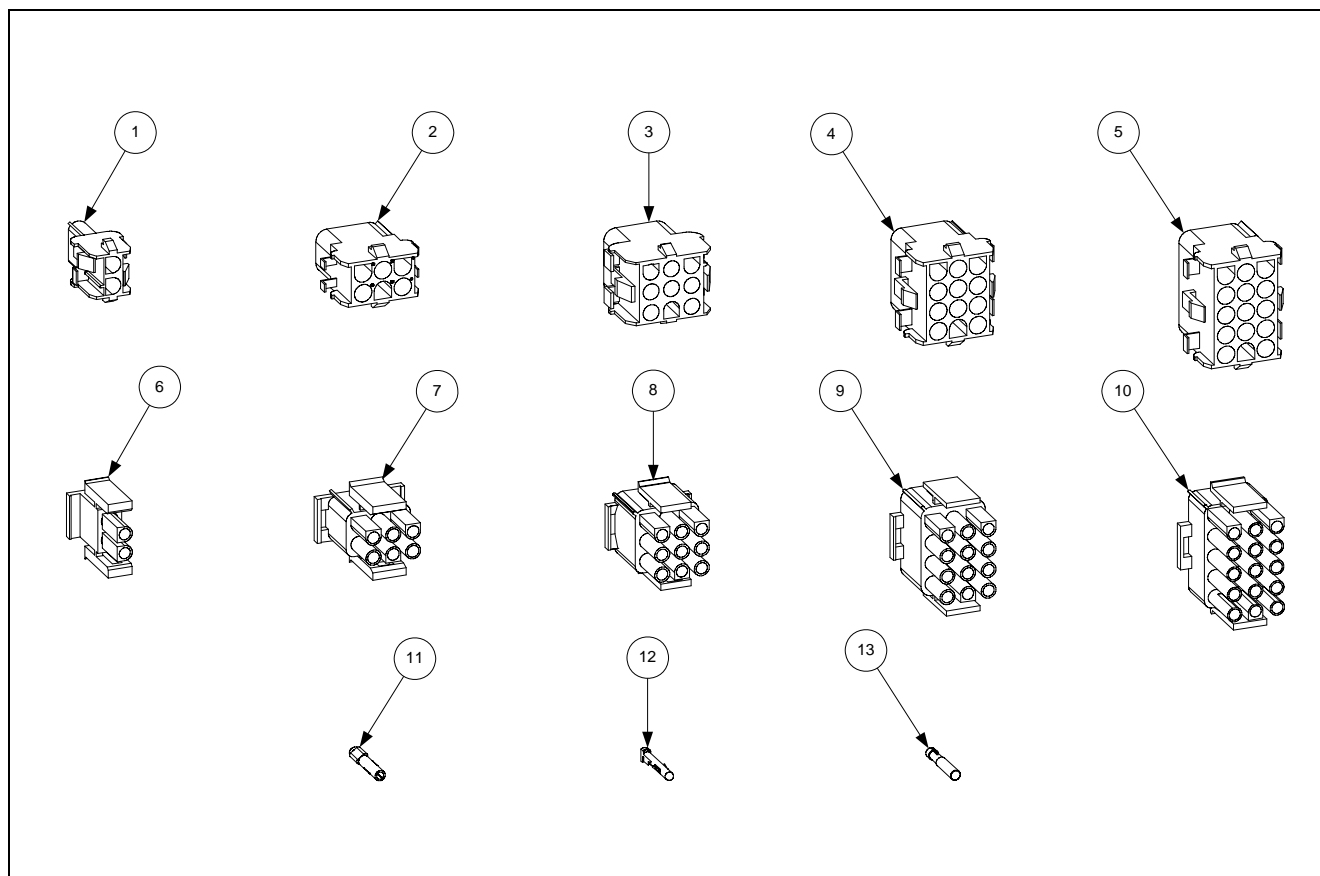

ITEM	PART #	COMPONENT
		<b>Power Cords</b>
*	106-0913SP	Power Cord Assembly 120V 10' 16 gauge
*	106-0516	Power Cord Assembly 220/250V 15A 5'8" 14 gauge
		<b>Connectors</b>
1	807-1068	2-Pin Female
2	807-0158	6-Pin Female
3	807-0156	9-Pin Female
4	807-0159	12-Pin Female
5	807-0875	15-Pin Female
6	807-1067	2-Pin Male
7	807-0157	6-Pin Male
8	807-0155	9-Pin Male
9	807-0160	12-Pin Male
10	807-0804	15-Pin Male
11	826-1341	Terminal, Female Split Pin (Pkg of 25)
12	826-1342	Terminal, Male Split Pin (Pkg of 25)
13	807-2518	Plug, Mate-N-Lock (Dummy Pin)

\* Not illustrated.



**24G SERIES FLATBOTTOM GAS FRYERS  
CHAPTER 2: PARTS LIST**

**2.8 Screws, Nuts, and Fasteners**

ITEM	PART #	COMPONENT
*	826-1389	Screw, ¼-20 x ¾-inch (Pkg. of 10)
*	826-1359	Screw, 4-40 x ¾-inch Slotted Round Head (Pkg. of 25)
*	809-0853	Screw, 10-32 x 1.5-inch Slotted Pan Head
*	809-0839	Screw, 8-32 x .75-inch Slotted Pan Head
*	809-0918	Screw, 10-24 x ½-inch
*	826-1371	Screw, #8 x .50-inch Slotted Hex Head (Pkg. of 25)
*	826-1374	Screw, #10 - ½-inch Hex Washer Head (Pkg. of 25)
*	809-0766	Nut, 10-32 Hex Head
*	809-0823	Nut, ¼-20 Nylock
*	809-0247	Nut, 8-32 Keps
*	809-0834	Nut, 8-32 Hex Locknut
*	826-1366	Nut, 4-40 Keps (Pkg. of 25) (used to mount microswitch)
*	809-0885	Washer, Flat ⅜-inch x 1-inch x .083"
*	809-0191	Washer, ¼-inch Lock

\* Not illustrated.

## 24G SERIES FLATBOTTOM GAS FRYERS CHAPTER 2: PARTS LIST

### APPENDIX: ND90 Built-In Filter System Components

**NOTES:** Early model 24G fryers were available only as single units. To create multi-fryer batteries, a number of single fryers were battered together with top connecting strips.

To provide built-in filtration for these batteries, a filter (with a dump station above it) was placed somewhere in the middle, as shown in the photograph below. The filter system is referred to as the **44210ND90**, or simply as the **ND90**.

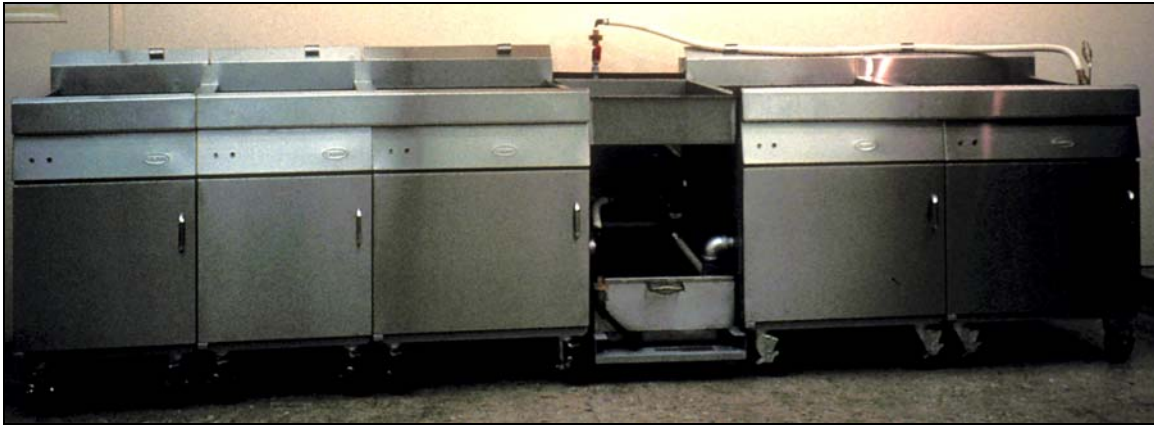

The first generation filter returned the shortening to the frypot using a hose and wand assembly. Later versions used a so-called “hands free” plumbing assembly attached to the backsplash of the dump station.

*The ND90 filter option was discontinued in 1996* when the fryer design was changed to incorporate the Under Fryer Filter (UFF) system. A large number of ND90-equipped fryers were produced and Frymaster/Dean continues to support them with replacement systems and parts, with the exception that the “hands free” plumbing components are no longer available.

A complete filter kit, illustrated below, may be ordered to replace existing ND90 filters in the field. **The kit does not include the oil return hose and wand assembly.** See page 2-19 for this part.

Part Number 44210ND90003

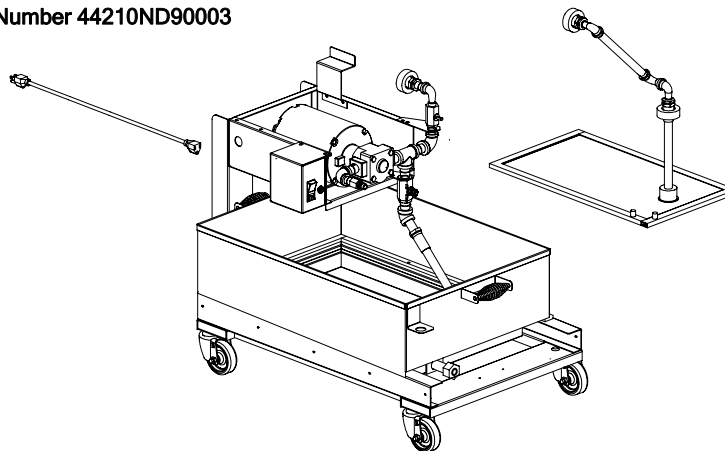

24G SERIES FLATBOTTOM GAS FRYERS  
CHAPTER 2: PARTS LIST

APPENDIX: ND90 Built-In Filter System Components (cont.)

**NOTE:** The parts illustrated below are available as individual parts only. See page 2-17 for the complete replacement filter assembly.

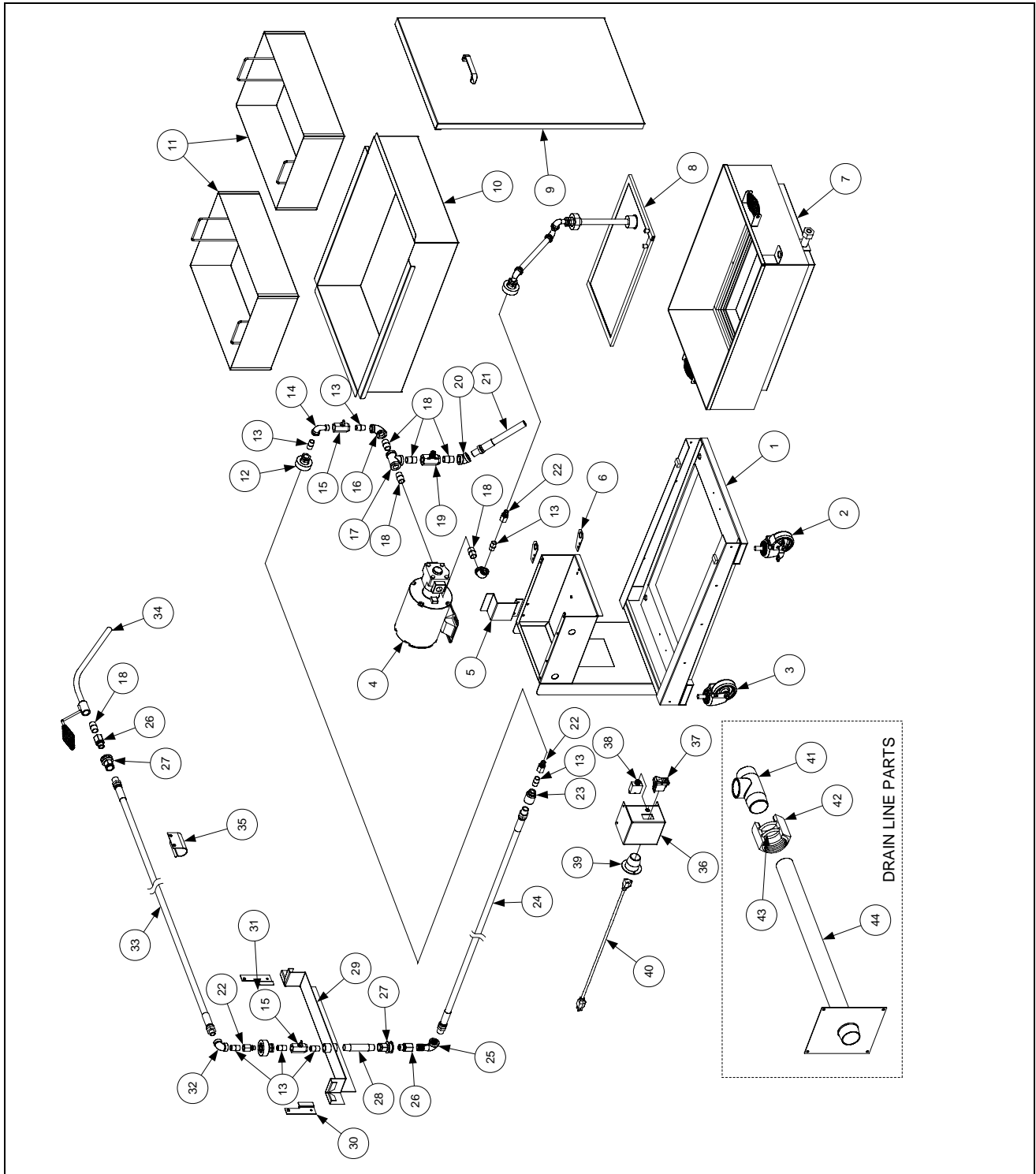

**24G SERIES FLATBOTTOM GAS FRYERS  
CHAPTER 2: PARTS LIST**

**APPENDIX: ND90 Built-In Filter System Components (cont.)**

ITEM	PART #	COMPONENT
1	823-3637	Filter Frame Assembly
2	810-2135	Caster without Brake, 3-inch
3	810-2136	Caster with Brake, 3-inch
4		Filter Pump and Motor Components
	810-2100	Motor, 120/230V 1/3 HP Filter Pump
	810-2252	Pump, 5GPM ( <i>use 810-2098 for 8GPM Pump</i> )
	810-2395	Seal, Shaft (O-Ring)
	809-0428	Bolt, 1/4-20 x 1/2-inch Hex Head (Motor Mount)
	809-0823	Nut, 1/4-20 Nylock (Motor Mount)
	809-0189	Washer, 1/4-inch Flat (Motor Mount)
5	200-3097	Holder, Hose
6	200-3096	Support, Pipe (Polish and Return Assemblies)
7	823-4078SP	Pan Assembly, ND90 Series
8	810-2237	Filter Leaf Assembly (includes leaf to pump plumbing and port fittings)
9	106-1939SP	Cover with Handle, Filter Front
10	823-3646	Holding Pan (for pan screen inserts)
11	823-3651	Insert, Pan Screen (two required for Item 49)
12	810-2762	Connector with Collar, 3/8-inch Female Quick Disconnect
*	816-0550	O-Ring, 3/8-inch Quick Disconnect ( <i>use 816-0545 for 1/2-inch</i> )
13	813-0625	Nipple, 3/8-inch x Close NPT
14	813-0632	Elbow, 3/8-inch x 90° NPT Street
15	810-2125	Valve, 3/8-inch Ball
*	230-0089	Handle, Ball Valve
16	813-0634	Elbow, 1/2-inch to 3/8-inch NPT Reduction
17	813-0003	Tee, 1/2-inch NPT
18	813-0022	Nipple, 1/2-inch x Close NPT
19	810-0278	Valve, 1/2-inch Ball
20	813-0345	Elbow, 1/2-inch x 45° NPT
21	810-2321	Hose Assembly, 7/4-inch (Polishing Hose)
22	810-2172	Connector, 3/8-inch Male Quick-Disconnect
23	813-0735	Reducer, 1/2-inch x 3/8-inch NPT Bell (used with Item 24)
24	810-2375	Hose Assembly, 1/2-inch x 32-inch
25	813-0165	Elbow, 1/2-inch x 90° NPT Street
26	810-2170	Connector, 1/2-inch Male Quick-Disconnect
27	810-2173	Connector without Collar, 1/2-inch Female Quick-Disconnect
28	813-0654	Nipple, 1/2-inch x 4-inch NPT
29	823-3642	Spreader Bracket Assembly
30	201-3105	Bracket, Left Spreader Assembly Holding
31	202-3105	Bracket, Right Spreader Assembly Holding
32	813-0631	Elbow, 3/8-inch x 90° NPT
33	810-2113	Hose, 1/2-inch x 3/8-inch x 61.5-inch Wash-Down
34	106-1454SP	Wand Assembly, Wash-Down Hose ( <i>use 810-2188 for wand only</i> )
35	210-3118	Bracket, Support- Wash-Down Hose
36	824-1090	Box, Switch/Circuit Breaker
37	807-3574	Switch, Power ON/OFF Rocker
38	807-3577	Circuit Breaker, 120VAC 7-Amp ( <i>use 807-3538 for 230VAC 5-Amp</i> )
39	807-1219	Receptacle, 120V 3-Wire
40	807-1224	Cordset, 120V 3-Wire
41	813-0770	Tee, 1 1/2-inch x 1 1/4-inch Offset No Flush Drainpipe ( <i>use 813-0768 for units with flush</i> )
*	813-0760	Tee, Drainpipe, 1 1/2-inch x 1 1/4-inch (all except right end)
*	813-0659	Cap, 1 1/2-inch Pipe (used with Item 41)
42	809-0884	Slip-Nut, 1 1/2-inch Drainpipe
43	816-0544	O-Ring, Slip-Nut (two required per slip-nut)
44	823-3652	Drainpipe, 1.625-inch Flanged (to left-hand filter)
*	200-1838	Drainpipe, 1.625 x 17 1/2-inch ( <i>use 200-1839 for 23 1/2-inch</i> )

\* Not illustrated.





Frymaster/Dean, 8700 Line Avenue, Shreveport, Louisiana 71106

TEL 1-318-865-1711

FAX (Parts) 1-318-688-2220

FAX (Tech Support) 1-318-219-7135

PRINTED IN THE UNITED STATES

SERVICE HOTLINE  
1-800-551-8633

819-6031  
SEPT 2011