

**SERVICE MANUAL
FRYMASTER BIRE14/MRE14 SERIES
ELECTRIC FRYER**



This equipment chapter is to be installed in the Fryer Section of the *Equipment Manual*.

FOR YOUR SAFETY
Do Not Store or use gasoline or other flammable vapors and liquids in the vicinity of this or any other appliance.

MANUFACTURED
BY

 **Frymaster**

 **Manitowoc**

P.O. BOX 51000
SHREVEPORT, LOUISIANA 71135-1000
PHONE: 1-318-865-1711
TOLL FREE: 1-800-551-8633
1-800-24 FRYER
FAX: 1-318-688-2200



Frymaster L.L.C., 8700 Line Avenue 71106
P.O. Box 51000, Shreveport, Louisiana 71135-1000
PHONE 318-865-1711 FAX 318-219-7135

PRINTED IN THE UNITED STATES

**SERVICE HOTLINE
1-800-24-FRYER**

www.frymaster.com

email: service@frymaster.com

AUG 2009

8196152*

NOTICE

IF, DURING THE WARRANTY PERIOD, THE CUSTOMER USES A PART FOR THIS ENODIS EQUIPMENT OTHER THAN AN UNMODIFIED NEW OR RECYCLED PART PURCHASED DIRECTLY FROM FRYMASTER DEAN, OR ANY OF ITS AUTHORIZED SERVICE CENTERS, AND OR THE PART BEING USED IS MODIFIED FROM ITS ORIGINAL CONFIGURATION, THIS WARRANTY WILL BE VOID. FURTHER, FRYMASTER DEAN AND ITS AFFILIATES WILL NOT BE LIABLE FOR ANY CLAIMS, DAMAGES OR EXPENSES INCURRED BY THE CUSTOMER WHICH ARISE DIRECTLY OR INDIRECTLY, IN WHOLE OR IN PART, DUE TO THE INSTALLATION OF ANY MODIFIED PART AND/OR PART RECEIVED FROM AN UNAUTHORIZED SERVICE CENTER.

NOTICE

This appliance is intended for professional use only and is to be operated by qualified personnel only. A Frymaster Dean Factory Authorized Service Center (FASC) or other qualified professional should perform installation, maintenance, and repairs. Installation, maintenance, or repairs by unqualified personnel may void the manufacturer's warranty.

NOTICE

This equipment must be installed in accordance with the appropriate national and local codes of the country and/or region in which the appliance is installed.

 DANGER

All wiring connections for this appliance must be made in accordance with the wiring diagrams furnished with the equipment. Wiring diagrams are located on the inside of the fryer door.

NOTICE TO U.S. CUSTOMERS

This equipment is to be installed in compliance with the basic plumbing code of the Building Officials and Code Administrators International, Inc. (BOCA) and the Food Service Sanitation Manual of the U.S. Food and Drug Administration.

NOTICE TO OWNERS OF UNITS EQUIPPED WITH COMPUTERS

U.S.

This device complies with Part 15 of the FCC rules. Operation is subject to the following two conditions: 1) This device may not cause harmful interference, and 2) This device must accept any interference received, including interference that may cause undesired operation. While this device is a verified Class A device, it has been shown to meet the Class B limits.

CANADA

This digital apparatus does not exceed the Class A or B limits for radio noise emissions as set out by the ICES-003 standard of the Canadian Department of Communications.

Cet appareil numérique n'émet pas de bruits radioélectriques dépassant les limites de classe A et B prescrites dans la norme NMB-003 édictée par le Ministre des Communications du Canada.

⚠ DANGER

Improper installation, adjustment, maintenance or service, and unauthorized alterations or modifications can cause property damage, injury, or death. Read the installation, operating, and service instructions thoroughly before installing or servicing this equipment.

⚠ DANGER

The front ledge of this appliance is not a step! Do not stand on the appliance. Serious injury can result from slips or contact with the hot oil.

⚠ DANGER

Do not store or use gasoline or other flammable liquids or vapors in the vicinity of this or any other appliance.

⚠ DANGER

The crumb tray in fryers equipped with a filter system must be emptied into a fireproof container at the end of frying operations each day. Some food particles can spontaneously combust if left soaking in certain shortening material.

⚠ WARNING

Do not bang fry baskets or other utensils on the fryer's joiner strip. The strip is present to seal the joint between the fry vessels. Banging fry baskets on the strip to dislodge shortening will distort the strip, adversely affecting its fit. It is designed for a tight fit and should only be removed for cleaning.

⚠ DANGER

Adequate means must be provided to limit the movement of this appliance without depending on or transmitting stress to the electrical conduit. A restraint kit is provided with the fryer. If the restraint kit is missing contact your local Frymaster Factory Authorized Service Center (FASC) for part number 826-0900.

⚠ DANGER

This fryer has two power cords and prior to movement, testing, maintenance and any repair on your Frymaster fryer; disconnect both electrical power cords from the electrical supply.

⚠ WARNING

Do not use water jets to clean this equipment.

WARRANTY STATEMENT

Frymaster, L.L.C. makes the following limited warranties to the original purchaser only for this equipment and replacement parts:

A. WARRANTY PROVISIONS - FRYERS

1. Frymaster L.L.C. warrants all components against defects in material and workmanship for a period of one year.
2. All parts, with the exception of the frypot, heating elements and fuses, are warranted for one year after installation date of fryer.
3. If any parts, except fuses and filter O-rings, become defective during the first year after installation date, Frymaster will also pay straight-time labor costs to replace the part, plus up to 100 miles/160 km of travel (50 miles/80 km each way).

B. WARRANTY PROVISIONS - FRYPOTS

(Applies to fryers manufactured after December 1, 2003, only.)

If a frypot develops a leak within ten years after installation, Frymaster will, at its option, either replace the entire battery or replace the frypot, allowing up to the maximum time per the Frymaster time allowance chart hours of straight-time labor plus up to 100 miles/160 km of travel (50 miles/80 km each way) to change the frypot.

C. WARRANTY PROVISIONS - HEATING ELEMENTS

1. Frymaster L.L.C. warrants the heating elements against defective material or workmanship for a period of three years from the original installation date, parts only.
2. This warranty does not cover ancillary components, including the high-limit, temperature probe, and contactors.

D. WARRANTY PROVISIONS - COOKING COMPUTER

1. Frymaster L.L.C. warrants the M-2000 Cooking Computer against defective material or workmanship for a period of one year from the original installation date, parts and labor. Replacements for defective units during the second year include part only. Labor is charged to the store during the second and third years. The third year, warranty will cover the part at a reduced cost of \$90.00.
2. During this warranty period, Frymaster will, at its option, repair or replace defective cooking computer returned with new or factory rebuilt and functionally operative units.
3. For replacement of defective computers under warranty, call your local Frymaster Factory Authorized Service Center. All computers replaced under the Frymaster exchange program only carry the remaining original warranty.

E. PARTS RETURN

All defective in-warranty parts must be returned to a Frymaster Authorized Factory Service Center within 60 days for credit. After 60 days, no credit will be allowed.

F. WARRANTY EXCLUSIONS

This warranty does not cover equipment that has been damaged due to misuse, abuse, alteration, or accident such as:

- improper or unauthorized repair (including any frypot which is welded in the field);
- failure to follow proper installation instructions and/or scheduled maintenance procedures as prescribed in your MRC cards. Proof of scheduled maintenance is required to maintain the warranty;
- improper maintenance;
- damage in shipment;
- abnormal use;
- removal, alteration, or obliteration of either the rating plate or the date code on the heating elements;
- operating the frypot without shortening or other liquid in the frypot;
- no fryer will be warranted under the ten-year program for which a proper start-up form has not been received.

This warranty also does not cover:

- transportation or travel over 100 miles/160 km (50 miles/80 km each way), or travel over two hours;
- overtime or holiday charges;
- consequential damages (the cost of repairing or replacing other property which is damaged), loss of time, profits, use or any other incidental damages of any kind.

There are no implied warranties of merchantability or fitness for any particular use or purpose.

This warranty is applicable at the time of this printing and is subject to change.

ELECTRICAL POWER SPECIFICATIONS

VOLTAGE	PHASE	WIRE SERVICE	MINIMUM WIRE SIZE		AMPS (per leg)
			AWG	(mm)	
208	Single	3	3	(5.83)	68
208	3	3	6	(4.11)	39
240	Single	3	4	(5.19)	59
240	3	3	6	(4.11)	34
480	Single	3	8	(3.26)	30
480	3	3	8	(2.59)	17
220/380	3	4	6	(4.11)	21
240/415	3	4	6	(4.11)	20
230/400	3	4	6	(4.11)	21

BIRE14/MRE14 SERIES E⁴ ELECTRIC FRYERS

TABLE OF CONTENTS

CAUTIONARY STATEMENTS	i
WARRANTY STATEMENT	ii
ELECTRICAL POWER SPECIFICATIONS	iv
CHAPTER 1: Service Procedures	
1.1 General.....	1-1
1.2 Replacing a Controller	1-1
1.3 Replacing Component Box Components.....	1-1
1.4 Replacing a High-Limit Thermostat	1-3
1.5 Replacing a Temperature Probe.....	1-3
1.6 Replacing a Heating Element.....	1-5
1.7 Replacing Contactor Box Components.....	1-6
1.8 Replacing a Frypot.....	1-7
1.9 Built-In Filtration System Service Procedures.....	1-9
1.9.1 Filtration System Problem Resolution.....	1-9
1.9.2 Replacing the Filter Motor, Filter Pump and Related Components.....	1-10
1.9.3 Replacing the Filter Transformer or Filter Relay	1-12
1.10 Interface Board Diagnostic Chart	1-13
1.11 Probe Resistance Chart	1-14
1.12 Wiring Diagrams.....	1-15
1.12.1 Component Wiring	1-15
1.12.2 Tilt Switch Wiring.....	1-16
1.12.3 Contactor Box-Delta Configuration.....	1-17
1.12.4 Contactor Box-WYE Configuration	1-18
1.12.5 Simplified Full-Vat Delta Wiring.....	1-19
1.12.6 Simplified Dual-Vat Delta Wiring.....	1-20
1.12.7 Simplified Full-Vat Export WYE Wiring.....	1-21
1.12.8 Simplified Dual-Vat Export WYE Wiring	1-22
1.12.9 Simplified Full-Vat EPRI Wiring.....	1-23
1.12.10 Simplified Full-Vat EPRI Wiring Export WYE Wiring.....	1-24
CHAPTER 2: Parts List	
2.1 Accessories	2-1
2.2 Cabinetry	2-2
2.2.1 Backs, Control Panel Frames, Doors, Sides, Tilt Housings and Top Caps	2-2
2.2.2 Cabinet Bases, Braces and Associated Parts	2-4
2.3 Drain System Components.....	2-6
2.3.1 Drain Tube Sections and Associated Parts	2-6
2.3.2 Drain Valves and Associated Parts (Units with Built-In Filtration)	2-8
2.3.3 Drain Valves and Associated Parts (Units without Built-In Filtration).....	2-12
2.4 Electronics and Electrical Components	2-13
2.4.1 Component Boxes.....	2-13
2.4.2 Contactor Boxes.....	2-15
2.4.3 Terminal Blocks.....	2-19
2.4.4 Heating Element Assemblies and Associated Parts.....	2-20
2.4.4.1 Element Assemblies and Hardware	2-20
2.4.4.2 Element Tube Assemblies	2-22
2.4.5 Computers.....	2-23
2.4.6 Wiring.....	2-24
2.4.6.1 Contactor Box Wiring Assemblies 12-Pin Dual Vat	2-24
2.4.6.2 Contactor Box Wiring Assemblies 12-Pin Full Vat	2-25
2.4.6.3 Contactor Box Wiring Assemblies 6-Pin Left Element.....	2-26

BIRE14/MRE14 SERIES E⁴ ELECTRIC FRYERS
TABLE OF CONTENTS cont.

2.4.6.4	Contactorm Box Wiring Assemblies 9-Pin Right Element.....	2-26
2.4.6.5	Main Wiring Harnesses.....	2-27
2.4.6.6	Component Box and Filter Pump Wiring Harnesses.....	2-28
2.4.6.7	Component Box to Filter Pump Harnesses.....	2-28
2.4.6.8	Interface Board to Controller Wiring Harness 15-Pin.....	2-29
2.5	Filtration System Components.....	2-30
2.6	Frypots and Associated Components.....	2-33
2.7	Oil Return System Components.....	2-35
2.8	Wiring Connectors, Pin Terminals and Power Cords.....	2-37
2.9	Fasteners.....	2-38

BIRE14/MRE14 SERIES ELECTRIC FRYERS

CHAPTER 1: SERVICE PROCEDURES

1.1 General

Before performing any maintenance on your Frymaster fryer, disconnect the fryer from the electrical power supply.

⚠ WARNING

To ensure the safe and efficient operation of the fryer and hood, the electrical plug for the 120-volt line, which powers the hood, must be fully engaged and locked in its pin and sleeve socket.

When electrical wires are disconnected, it is recommended that they be marked in such a way as to facilitate re-assembly.

1.2 Replacing a Computer

1. Disconnect the fryer from the electrical power supply.
2. The controller bezel is held in place by tabs at the top and bottom. Slide the metal bezel up to disengage the lower tabs. Then slide the bezel down to disengage the upper tabs.
3. Remove the two screws from the upper corners of the control panel. The control panel is hinged at the bottom and will swing open from the top.
4. Unplug the wiring harness from the connector on the back of the computer and disconnect the grounding wire from terminal adjacent to the connector. Remove the control panel assembly by lifting it from the hinged slots in the control panel frame.



5. Remove the controller from the control panel assembly and install the replacement computer. Reinstall the control panel assembly by reversing steps 1 and 2.

1.3 Replacing Component Box Components

1. Disconnect the fryer from the electrical power supply.
2. The controller bezel is held in place by tabs at the top and bottom. Slide the metal bezel up to disengage the lower tabs. Then slide the bezel down to disengage the upper tabs.

3. Remove the two screws from the upper corners of the control panel and allow the control panel to swing down.
4. Unplug the wiring harness from the 15-pin connector on the interface board and disconnect the grounding wire from terminal adjacent to the 15-pin connector on the back of the controller. Remove the control panel assembly by lifting it from the hinge slots in the control panel frame.
5. Disconnect the wiring from the component to be replaced, being sure to make a note of where each wire was connected.
6. Dismount the component to be replaced and install the new component, being sure that any required spacers, insulation, washers, etc. are in place.

NOTE: If more room to work is required, the control panel frame assembly may be removed by removing the hex head screws that secure it to the fryer cabinet (see illustration below). If this option is chosen, all control panel assemblies must be removed per steps 1 and 2 above. The cover plate on the lower front of the component box may also be removed if desired. *Removing the component box itself from the fryer is not recommended due to the difficulty involved in disconnecting and reconnecting the oil-return valve rods, which pass through openings in the component box.*

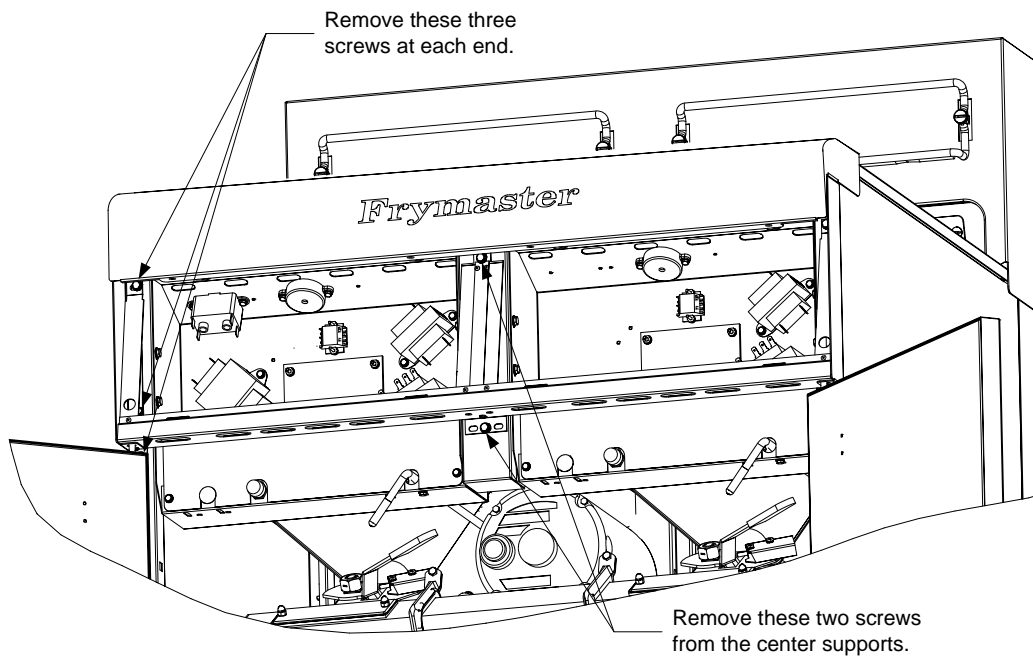

Removing the Control Panel Frame and Top Cap Assembly

7. Reconnect the wiring disconnected in step 3, referring to your notes and the wiring diagrams on the fryer door to ensure that the connections are properly made. Also, verify that no other wiring was disconnected accidentally during the replacement process.
8. Reverse steps 1 through 4 to complete the replacement and return the fryer to service.

1.4 Replacing a High-Limit Thermostat

1. Remove the filter pan and lid from the unit. Drain the frypots into an McDonald's Shortening Disposal Unit (MSDU) or other appropriate metal container.



DANGER

DO NOT drain more than one full frypot or two split frypots into the MSDU at one time.

2. Disconnect the fryer from the electrical power supply and reposition it to gain access to the rear of the fryer.
3. Remove the four screws from both the left and right sides of the lower back panel.
4. Locate the high-limit that is being replaced and follow the two-black wires to the 12-pin connector C-6. Note where the leads are connected prior to removing them from the connector. Unplug the 12-pin connector C-6 and using a pin-pusher push the pins of the high-limit out of the connector.
5. Using a wrench, carefully unscrew the high-limit thermostat to be replaced.
6. Apply Loctite™ PST 567 or equivalent sealant to the threads of the replacement and screw it securely into the frypot.
7. Insert the leads into the 12-pin connector C-6 (see illustration below). For full-vat units or the left half of a dual-vat unit (as viewed from the rear of the fryer) the leads go into positions 1 and 2 of the connector. For the right half of a dual-vat unit (as viewed from the rear of the fryer), the leads go into positions 7 and 8. In either case, polarity does not matter.

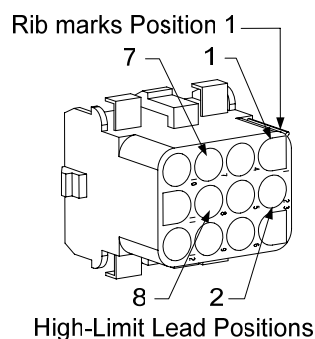

8. Reconnect the 12-pin connecting plug C-6. Use wire ties to secure any loose wires.
9. Reinstall the back panels, reposition the fryer under the exhaust hood, and reconnect it to the electrical power supply to return the fryer to service.

1.5 Replacing a Temperature Probe

1. Remove the filter pan and lid from the unit. Drain the frypots into a McDonald's Shortening Disposal Unit (MSDU) or other appropriate metal container.



DANGER

DO NOT drain more than one full frypot or two split frypots into the MSDU at one time.

2. Disconnect the fryer from the electrical power supply and reposition it to gain access to the rear of the fryer.
3. Remove the four screws from both sides of the lower back panel. Then remove the two screws on both the left and right sides of the back of the tilt housing. Lift the tilt housing straight up to remove from the fryer.
4. Locate the red and white wires of the temperature probe to be replaced. Note where the leads are connected prior to removing them from the connector. Unplug the 12-pin connector C-6 and using a pin-pusher push the pins of the temperature probe out of the connector.
5. Raise the element and remove the securing probe bracket and metal tie wraps that secure the probe to the element (see illustration below).

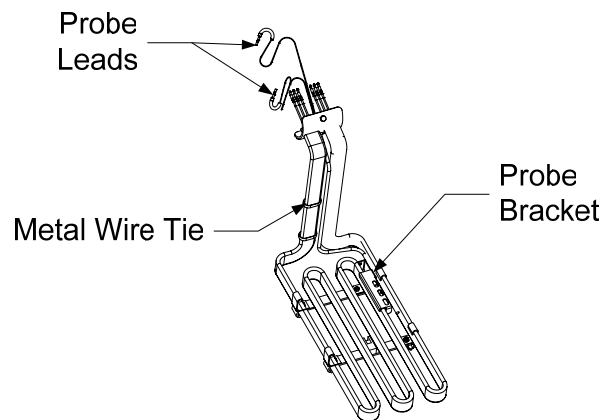

6. Gently pull on the temperature probe and grommet, pulling the wires up the rear of the fryer and through the element tube assembly.
7. Insert the replacement temperature probe (wires first) into the tube assembly ensuring that the grommet is in place. Secure the probe to the elements using the bracket which was removed in Step 5 and the metal tie wraps which were included in the replacement kit.
8. Route the probe wires out of the tube assembly following the element wires down the back of the fryer through the Heyco bushings to the 12-pin connector C-6. Secure the wires to the sheathing with wire ties.
9. Insert the temperature probe leads into the 12-pin connector C-6 (see illustration below). For full-vat units or the right half of a dual-vat unit (as viewed from the rear of the fryer) the red lead goes into position 3 and the white lead into position 4 of the connector. For the left half of a dual-vat unit (as viewed from the rear of the fryer), the red lead goes into position 9 and the white lead into position 10. **NOTE: Right and left** refer to the fryer as viewed from the rear.

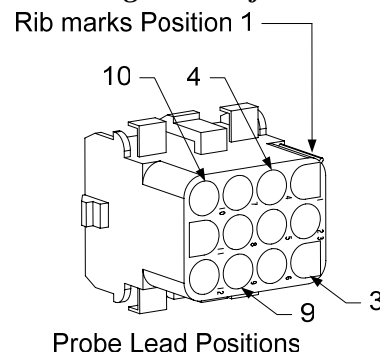

10. Secure any loose wires with wire ties making sure that the lead wires will not interfere with the movement of the springs. Rotate the elements up and down making sure that movement is not restricted and that the wires are not pinched.
11. Reinstall the tilt housing and back panels, reposition the fryer under the exhaust hood, and reconnect it to the electrical power supply to return the fryer to service.

1.6 Replacing a Heating Element

1. Perform steps 1-3 of section 1.5, *Replacing a Temperature Probe*.
2. On dual-vat fryers, and on full-vat fryers where the temperature probe is attached to the element being replaced, disconnect the wire harness containing the probe wiring. Using a pin pusher, disconnect the probe wires from the 12-pin connector C-6.
3. In the rear of the fryer directly behind the frypot disconnect the 6-pin connector for the left element (as viewed from the front of the fryer) or the 9-pin connector for the right element. Press in on the tabs on each side of the connector while pulling outward on the free end to extend the connector and release the element leads (see photo below). Pull the leads out of the connector and out of the wire sleeving.

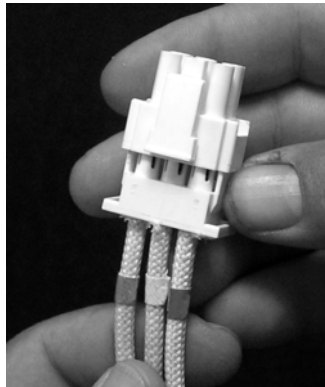

4. Raise the element to the full up position and support the elements.
5. Remove the hex head screws and nuts that secure the element to the tube assembly and pull the element out of the frypot. **NOTE:** Full-vat elements consist of two dual-vat elements clamped together. For full-vat units, remove the element clamps before removing the nuts and screws that secure the element to the tube assembly.
6. If applicable, recover the probe bracket and probe from the element being replaced and install them on the replacement element. Install the replacement element in the frypot, securing it with the nuts and screws removed in Step 5 to the tube assembly. Ensure the gasket is between the tube and element assembly.
7. Route the element leads through the element tube assembly and into the wire sleeving to prevent chafing. Ensure that the wire sleeving is routed back through the Heyco bushing keeping it clear from the lift springs. Also ensure that the wire sleeving extends into the tube assembly to protect the edge of the tube assembly from chafing the wires. Press the pins into the connector in accordance with the diagram on the following page, and then close the connector to lock the

leads in place. **NOTE:** It is critical that the wires be routed through the sleeving to prevent chafing.

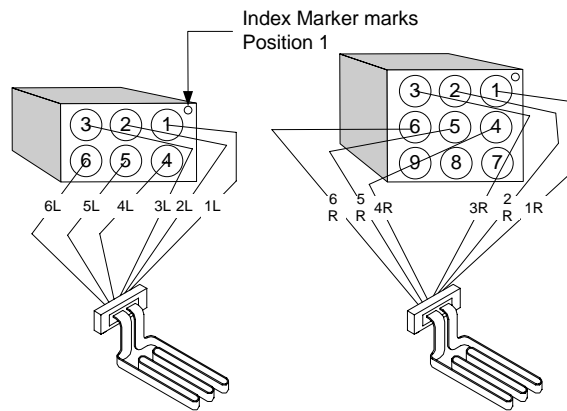

8. Reconnect the element connector ensuring that the latches lock.
9. Insert the temperature probe leads into the 12-pin wiring harness connector C-6 (see illustration below). For full-vat units or the right half of a dual-vat unit, the red lead goes into position 3 and the white into position 4. For the left half of a dual-vat unit, the red lead goes into position 9 and the white into position 10. **NOTE:** *Right* and *left* refer to the fryer as viewed from the rear.

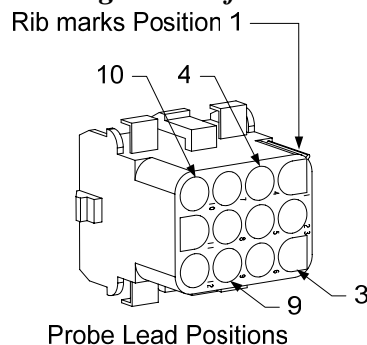

10. Reconnect the 12-pin connector C-6 of the wiring harness disconnected in Step 2.
11. Lower the element down onto the basket rack.
12. Reinstall the tilt housing and back panels, reposition the fryer under the exhaust hood, and reconnect it to the electrical power supply.

1.7 Replacing Contactor Box Components

1. If replacing a contactor box component above the built-in filter system, remove the filter pan and lid from the unit. Drain the frypots into a McDonald's Shortening Disposal Unit (MSDU) or other appropriate metal container. If replacing a contactor box component in a non-filter unit or a frypot that's not over the filter pan, drain the frypot above the box into a McDonald's Shortening Disposal Unit (MSDU) or other appropriate metal container.

⚠ DANGER

DO NOT drain more than one full frypot or two split frypots into the MSDU at one time.

2. Disconnect the fryer from the electrical power supply.
3. Remove the two screws securing the cover of the contactor box. The contactor boxes above the filter pan are accessed by sliding under the fryer. They are located to the left and right above the guide rails (see photo below). The contactor boxes of non-filter units or frypots not over the filter pan are accessed by opening the fryer door directly under the affected frypot.

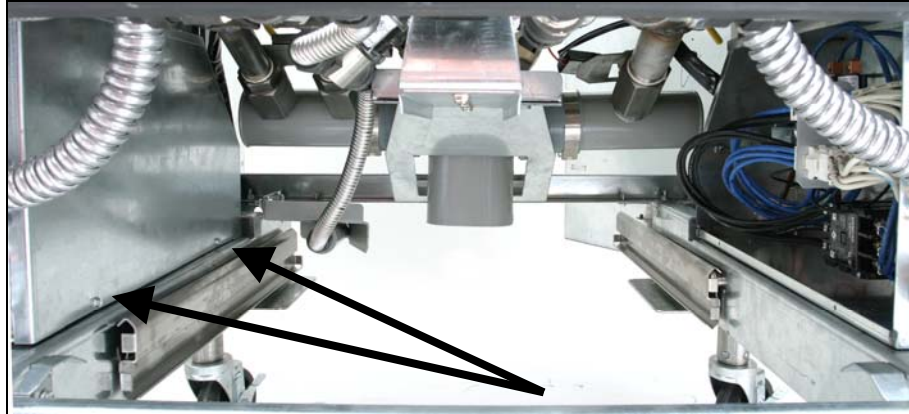

Remove two screws to access contactor box components above the filter pan.

4. The contactors and relays are held on by threaded pin studs so that only removal of the nut is required to replace the component.
5. After performing necessary service, reverse steps 1-4 to return the fryer to operation.



Left and right views of mechanical contactor box components.

1.8 Replacing a Frypot

1. Drain the frypot into the filter pan or, if replacing a frypot over the filter system, into a McDonald's Shortening Disposal Unit (MSDU) or other appropriate metal container. If replacing a frypot over the filter system, remove the filter pan and lid from the unit.

⚠ DANGER

DO NOT drain more than one full frypot or two split frypots into the MSDU at one time.

2. Disconnect the fryer from the electrical power supply and reposition it to gain access to both the front and rear.

3. Slide the metal bezel up to release the bottom tabs, then slide the bezel down to disengage the upper tabs.
4. Remove the two screws from the upper corners of the control panels and allow them to swing down (see illustration and photo on page 1-1).
5. Unplug the wiring harnesses and ground wires from the backs of the controllers. Remove the controllers by lifting them from the hinge slots in the control panel frame.
6. Remove the tilt housing and back panels from the fryer. The tilt housing must be removed first in order to remove the upper back panel.
7. To remove the tilt housing remove the hex head screws from the rear edge of the housing. The housing can be lifted straight up and off the fryer.
8. Remove the control panel by removing the screw in the center and the nuts on both sides.
9. Loosen the component boxes by removing the screws, which secure them in the cabinet.
10. Dismount the top cap by removing the nuts at each end that secure it to the cabinetry.
11. Remove the hex head screw that secures the front of the frypot to the cabinet cross brace.
12. Remove the top-connecting strip that covers the joint with the adjacent frypot.
13. Unscrew the Teflon vent/vacuum-breaker tube fitting, unscrew the nut located on the front of each section of drain tube, and remove the tube assembly from the fryer.
14. Remove the covers from the drain safety switch(es) and disconnect the switch wiring at the switch(es).
15. At the rear of the fryer, unplug the 12-pin connector C-6 and, using a pin pusher, disconnect the high-limit thermostat leads.
16. Disconnect the oil return flexline(s) at the frypot end(s).
17. Raise the elements to the “up” position and disconnect the element springs.
18. Remove the machine screws and nuts that secure the element tube assembly to the frypot. Carefully lift the element assembly from the frypot and secure it to the cross brace on the rear of the fryer with wire ties or tape.
19. Carefully lift the frypot from the fryer and place it upside down on a stable work surface.
20. Recover the drain valve(s), oil return flexline connection fitting(s), and high-limit thermostat(s) from the frypot. Clean the threads and apply Loctite™ PST 567 or equivalent sealant to the threads of the recovered parts and install them in the replacement frypot.
21. Carefully lower the replacement frypot into the fryer. Reinstall the hex head screw removed in step 7 to attach the frypot to the fryer.

22. Position the element tube assembly in the frypot and reinstall the machine screws and nuts removed in step 14.
23. Reconnect the oil return flexlines to the frypot, and replace aluminum tape, if necessary, to secure heater strips to the flexlines.
24. Insert the high-limit thermostat leads disconnected in step 13 (see illustration on page 1-3 for pin positions).
25. Reconnect the drain safety switch wiring to the switch(es) in accordance with the diagram below then reinstall the switch covers.

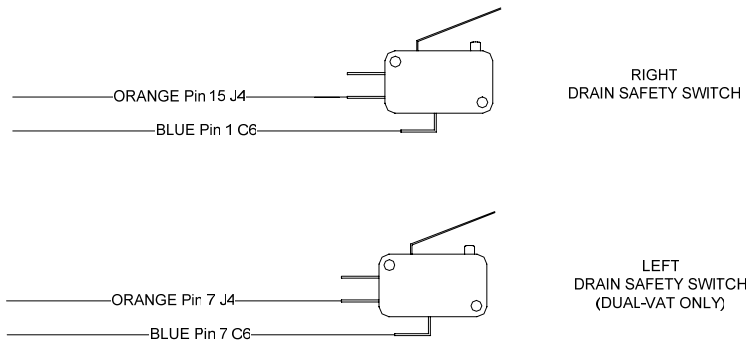

26. Reinstall the drain tube assembly.
27. Reinstall the top connecting strips, top cap, tilt housing and back panels.
28. Reinstall controllers in the control panel frame and reconnect the wiring harnesses and ground wires.
29. Reposition the fryer under the exhaust hood and reconnect it to the electrical power supply.

1.9 Built-in Filtration System Service Procedures

1.9.1 Filtration System Problem Resolution

One of the most common causes of filtration problems is placing the filter paper on the bottom of the filter pan rather than over the filter screen.

⚠ CAUTION
Ensure that filter screen is in place prior to filter paper placement and filter pump operation. Improper screen placement is the primary cause of filtration system malfunction.

Whenever the complaint is “the pump is running, but no oil is being filtered,” check the installation of the filter paper, and ensure that the correct size is being used. While you are checking the filter paper, verify that the O-rings on the pick-up tube of the filter pan are in good condition. A missing or worn O-rings allow the pump to take in air and decrease its efficiency.

If the pump motor overheats, the thermal overload will trip and the motor will not start until it is reset. If the pump motor does not start, press the red reset switch (button) located on the rear of the motor.

If the pump starts after resetting the thermal overload switch, then something is causing the motor to overheat. A major cause of overheating is when several frypots are filtered sequentially, overheating the pump and motor. Allow the pump motor to cool at least 30 minutes before resuming operation. Pump overheating can be caused by:

- Solidified shortening in the pan or filter lines, or
- Attempting to filter unheated oil or shortening (cold oil and shortening are more viscous, overloading the pump motor and causing it to overheat).

If the motor runs but the pump does not return oil, there is a blockage in the pump. Incorrectly sized or installed paper/pads will allow food particles and sediment to pass through the filter pan and into the pump. When sediment enters the pump, the gears bind, causing the motor to overload, again tripping the thermal overload. Shortening that has solidified in the pump will also cause it to seize, with the same result.

A pump seized by debris or hard shortening can usually be freed by manually moving the gears with a screwdriver or other instrument.

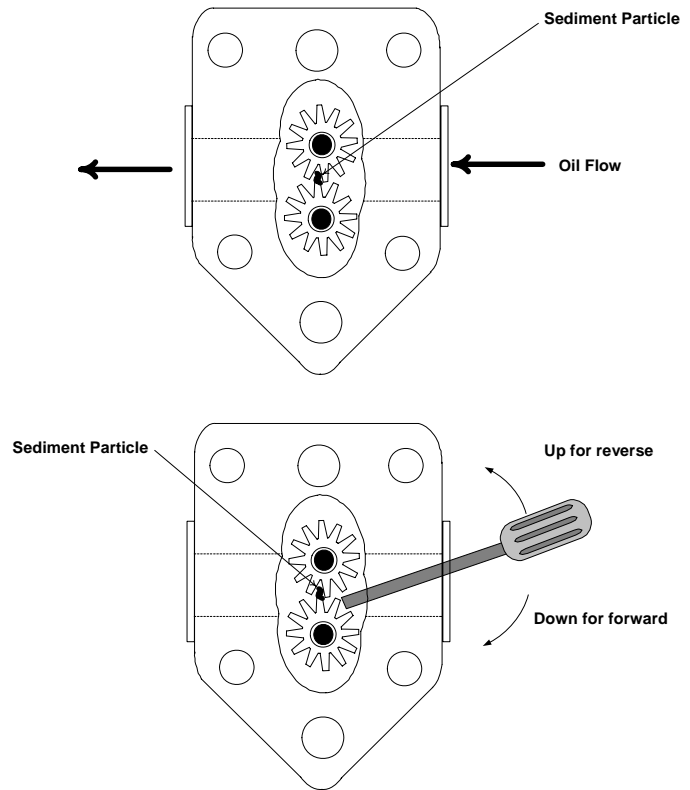

Disconnect power to the filter system, remove the input plumbing from the pump, and use a screwdriver to manually turn the gears.

- Turning the pump gears in reverse will release a hard particle.
- Turning the pump gears forward will push softer objects and solid shortening through the pump and allow free movement of the gears.

Incorrectly sized or installed paper/pads will also allow food particles and sediment to pass through and clog the suction tube on the bottom of the filter pan. Particles large enough to block the suction tube may indicate that the crumb tray is not being used. Pan blockage can also occur if shortening is left in the pan and allowed to solidify. Blockage removal can be accomplished by forcing the item out with an auger or drain snake. Compressed air or other pressurized gases should not be used to force out the blockage.

1.9.2 Replacing the Filter Motor, Filter Pump, and Related Components

1. Remove the filter pan and lid from the unit. Drain the frypots into a McDonald's Shortening Disposal Unit (MSDU) or other appropriate metal container.

⚠ DANGER

DO NOT drain more than one full frypot or two split frypots into the MSDU at one time.

2. Disconnect the fryer from the electrical power supply and reposition it to gain access to both the front and rear.
3. Disconnect the two flexlines running to the oil-return manifold at the rear of the fryer as well as the pump suction flexline at the end of the filter pan connection (see photo below).

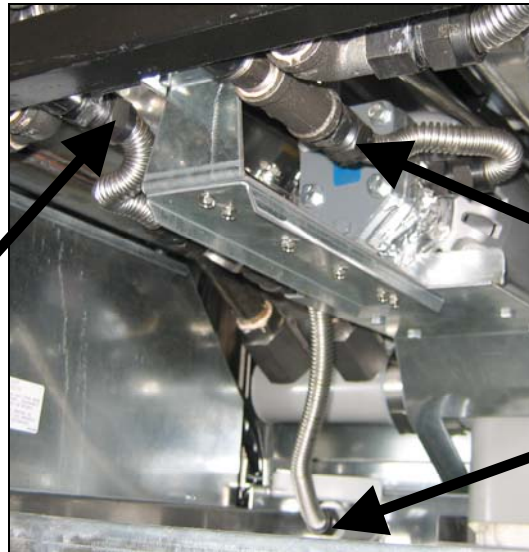

Disconnect flexlines indicated by the arrows.

4. Loosen the nut and bolt that secures the bridge to the oil-return manifold.
5. Remove the cover plate from the front of the motor and disconnect the motor wires.
6. Unplug the pump motor assembly 6-pin connector C-2 and, using a pin pusher, disconnect the vent vacuum-breaker solenoid (pins 2 and 5) that is attached to the oil return manifold.
7. Remove the two nuts and bolts that secure the front of the bridge to the cross brace and carefully slide the bridge rearward off the cross brace until its front end can be lowered to the floor. Undo the single nut holding it in place in back. Be careful not to let the rear of the bridge slip off the manifold at this point.
8. Get a good grip on the bridge, carefully pull it forward off the oil-return manifold, and lower the entire assembly to the floor. Once on the floor, pull the assembly out the front of the fryer.
9. When required service has been completed, reverse steps 6-12 to reinstall the bridge. **NOTE:** The black motor wires go on the top terminal, the white on the bottom. The pump solenoid valve wires go in positions 1 and 4 of the 6-pin connector C-2; the vent vacuum-breaker solenoid valve wires go in positions 2 and 5; the red/black heater tape wires go into position 3 and the violet/white wires go into position 6 (see illustration below).

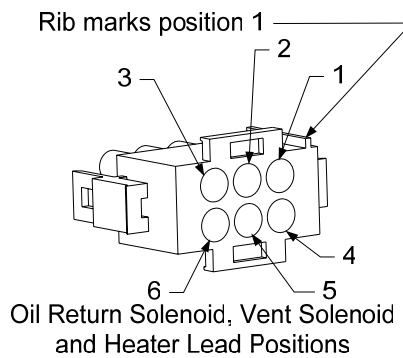

10. Reconnect the unit to the electrical power supply, and verify that the pump is functioning correctly (i.e., when a filter handle is placed in the ON position, the motor should start and there should be strong suction at the intake fitting and outflow at the rear flush port.)
11. When proper operation has been verified, reinstall the back panels and the filter pan and lid.
12. Reposition the fryer under the exhaust hood and reconnect it to the electrical power supply to return the fryer to service.

1.9.3 Replacing the Filter Transformer or Filter Relay

Disconnect the fryer from the electrical power supply. Remove the left controller from the fryer to expose the interior of the left component box. The filter transformer and relay are located as shown in the illustration below. **NOTE:** The right component box is identical to the left except that the filter transformer and relay are not present.

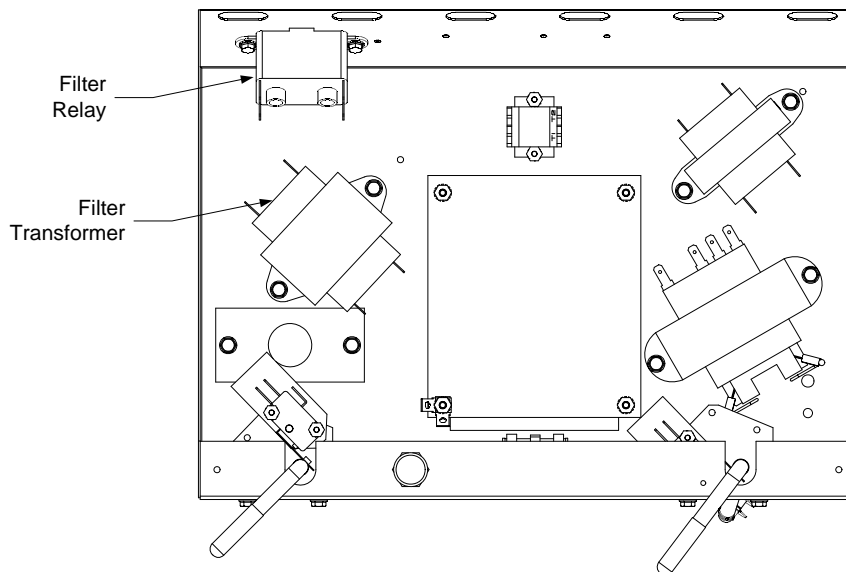

Dual-vat configuration illustrated. In full-vat units, left filter handle is not present.

1.10 Interface Board Diagnostic Chart

The following diagram and charts provide ten quick system checks that can be performed using only a multimeter.

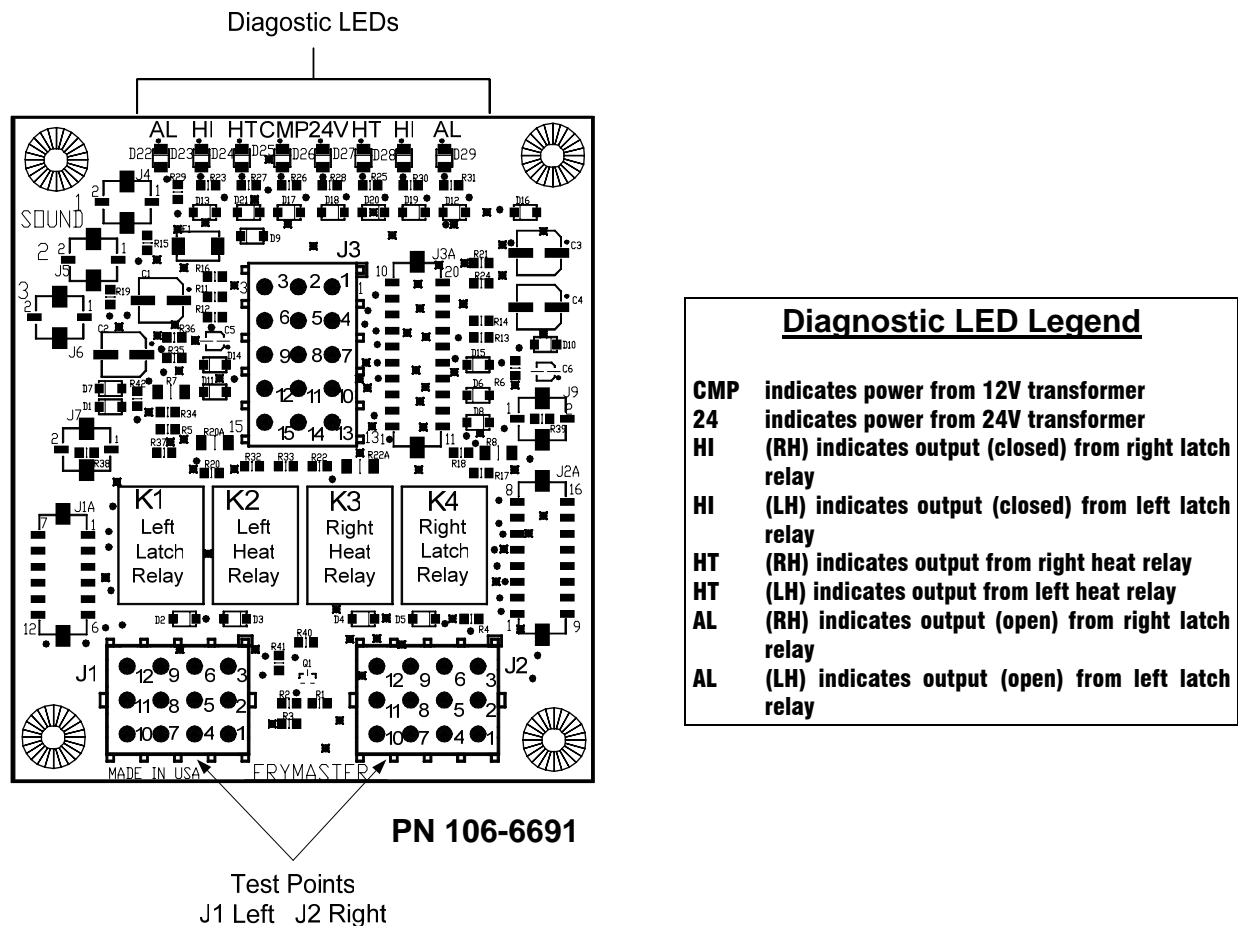

NOTE – When testing the test points on J1 and J2 test use the illustration above disregarding any silk-screened numbers on the board depicting the location of Pin 1. Pin 1 is located in the bottom right corner of Both J1 and J2. These test points are **ONLY** for RE Series boards with J1 and J2 plugs on the front of the board.

Meter Setting	Test	Pin	Pin	Results
12 VAC Power	50 VAC Scale	3 of J2	1 of J2	12-16 VAC
24 VAC Power	50 VAC Scale	2 of J2	Chassis	24-30 VAC
*Probe Resistance (RH)	R X 1000 OHMS	11 of J2	10 of J2	See Chart
*Probe Resistance (LH)	R X 1000 OHMS	1 of J1	2 of J1	See Chart
High-Limit Continuity (RH)	R X 1 OHMS	9 of J2	6 of J2	0 - OHMS
High-Limit Continuity (LH)	R X 1 OHMS	6 of J1	9 of J1	0 - OHMS
Latch Contactor Coil (RH)	R X 1 OHMS	8 of J2	Chassis	3-10 OHMS
Latch Contactor Coil (LH)	R X 1 OHMS	5 of J1	Chassis	3-10 OHMS
Heat Contactor Coil (RH)	R X 1 OHMS	7 of J2	Chassis	11-15 OHMS
Heat Contactor Coil (LH)	R X 1 OHMS	4 of J1	Chassis	11-15 OHMS

* **Disconnect 15-Pin harness from the computer/controller before testing the probe circuit.**

1.11 Probe Resistance Chart

<h3 style="text-align: center;">Probe Resistance Chart</h3> <p style="text-align: center;"><i>For use with fryers manufactured with Minco Thermistor probes only.</i></p>																	
F	OHMS	C	F	OHMS	C	F	OHMS	C	F	OHMS	C	F	OHMS	C			
60	1059	16	130	1204	54	200	1350	93	270	1493	132	340	1634	171			
65	1070	18	135	1216	57	205	1361	96	275	1503	135	345	1644	174			
70	1080	21	140	1226	60	210	1371	99	280	1514	138	350	1654	177			
75	1091	24	145	1237	63	215	1381	102	285	1524	141	355	1664	179			
80	1101	27	150	1247	66	220	1391	104	290	1534	143	360	1674	182			
85	1112	29	155	1258	68	225	1402	107	295	1544	146	365	1684	185			
90	1122	32	160	1268	71	230	1412	110	300	1554	149	370	1694	188			
95	1133	35	165	1278	74	235	1422	113	305	1564	152	375	1704	191			
100	1143	38	170	1289	77	240	1432	116	310	1574	154	380	1714	193			
105	1154	41	175	1299	79	245	1442	118	315	1584	157	385	1724	196			
110	1164	43	180	1309	82	250	1453	121	320	1594	160	390	1734	199			
115	1174	46	185	1320	85	255	1463	124	325	1604	163	395	1744	202			
120	1185	49	190	1330	88	260	1473	127	330	1614	166	400	1754	204			
125	1195	52	195	1340	91	265	1483	129	335	1624	168	405	1764	207			

1.12 Wiring Diagrams

1.12.1 Component Wiring

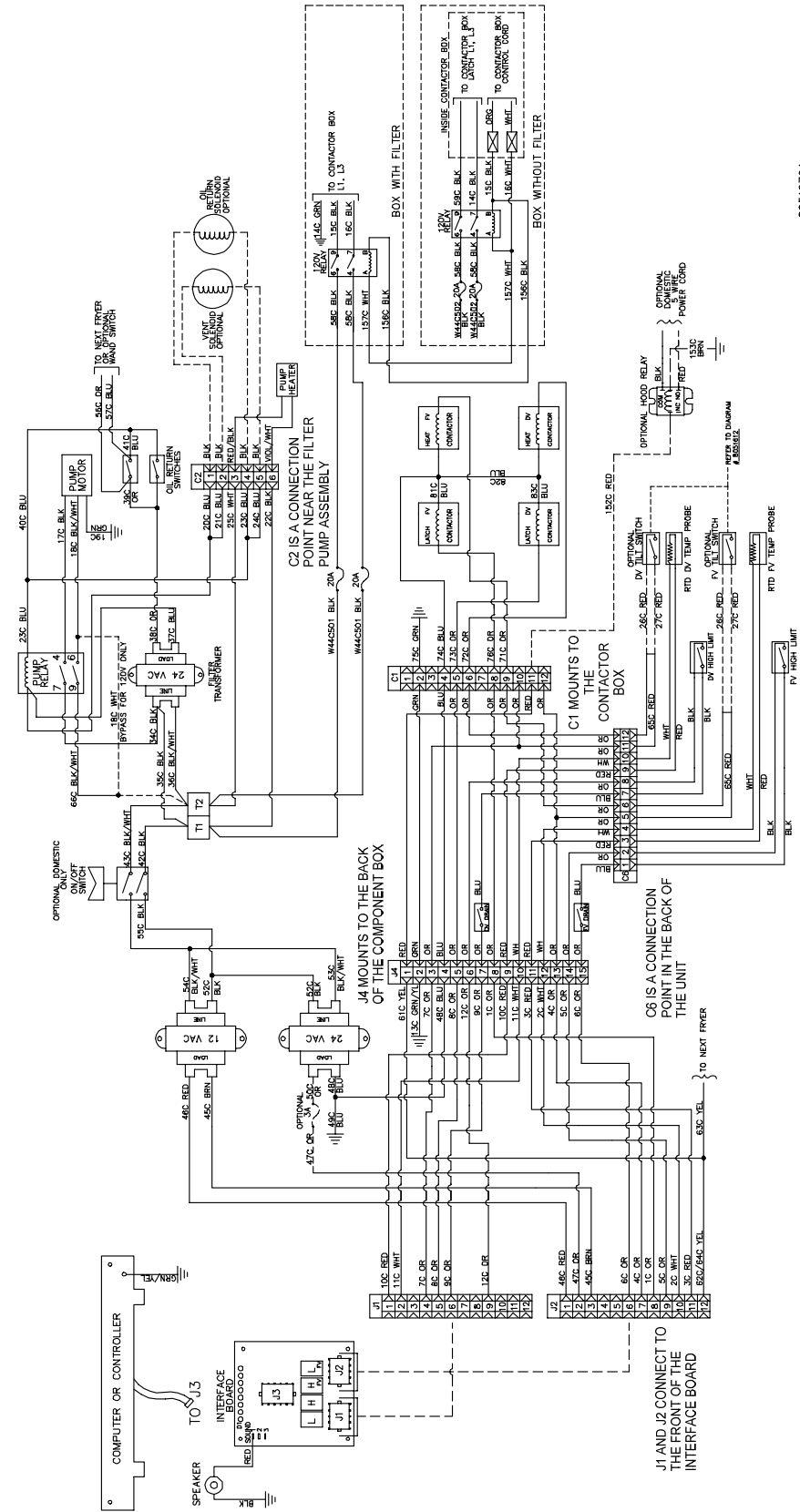

8051679A

1.12.2 Tilt Switch Wiring

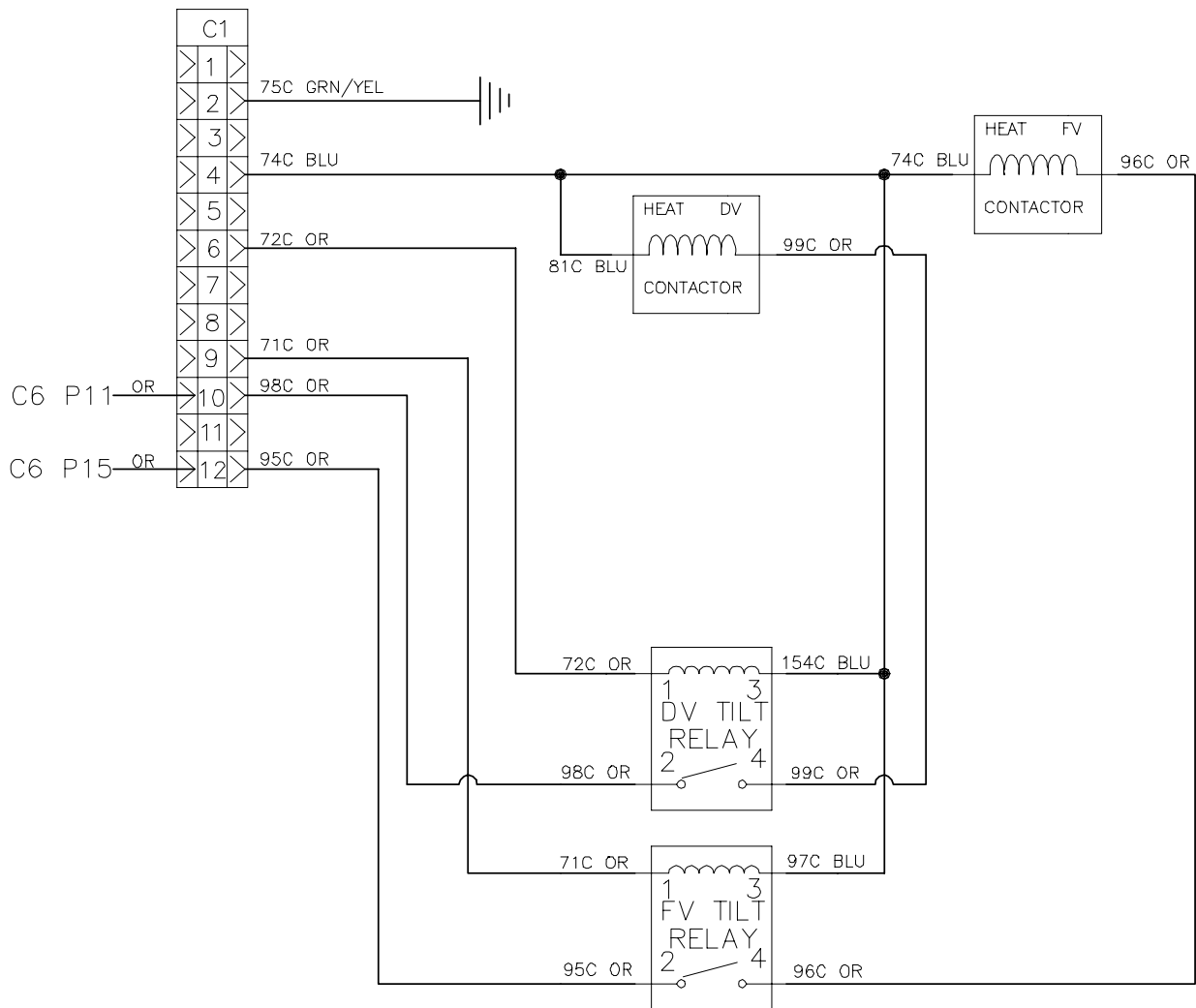

8051612B

1.12.3 Contactor Box – Delta Configuration

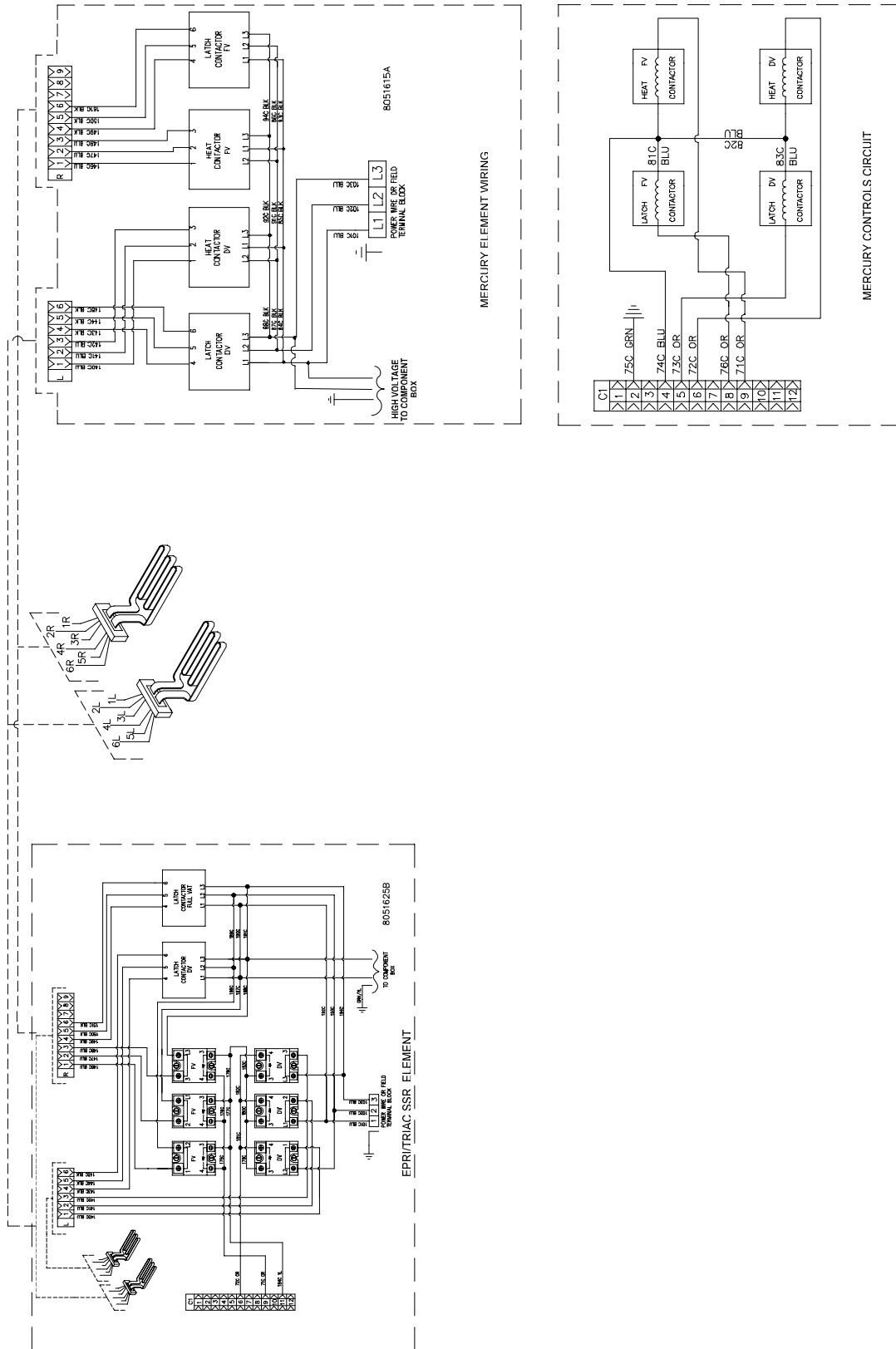

1.12.4 Contactor Box – WYE Configuration

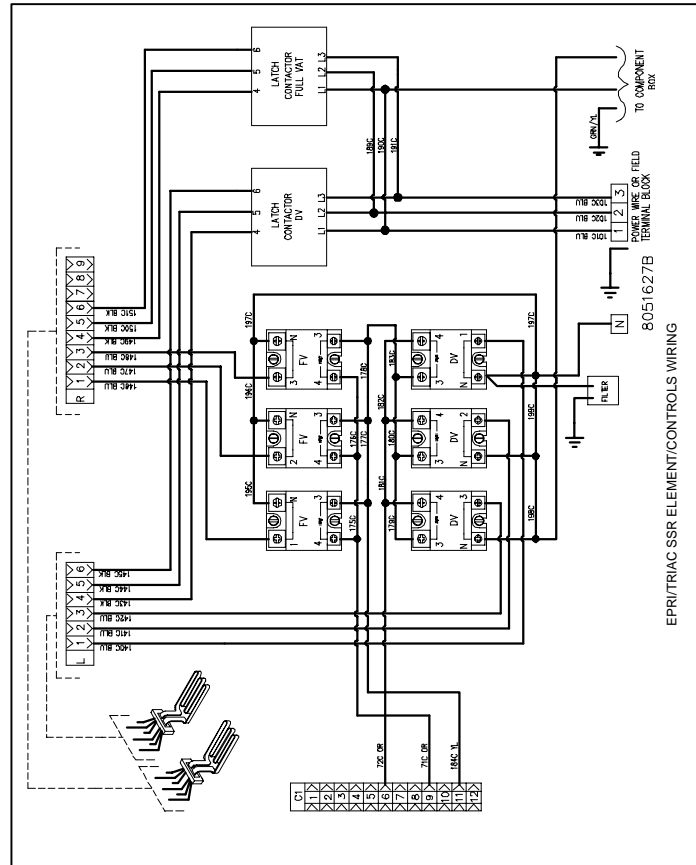
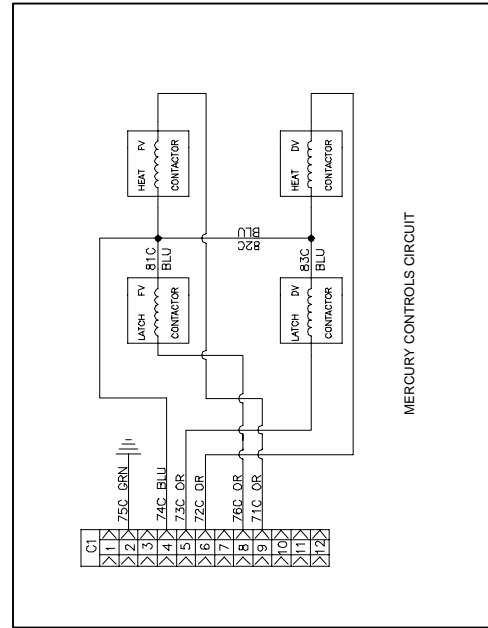
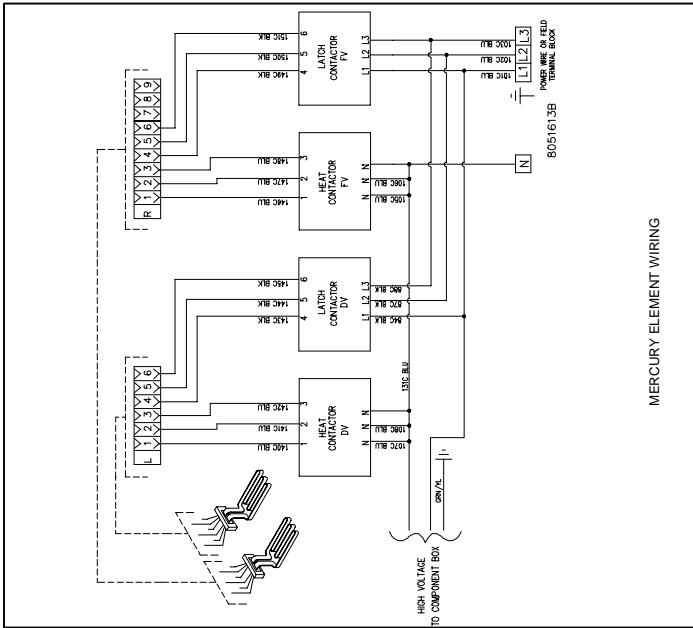

1.12.5 Simplified BIRE/MRE14 Series – Full Vat Delta Wiring

ELECTRIC BIRE/MRE14 SERIES - FULL-VAT

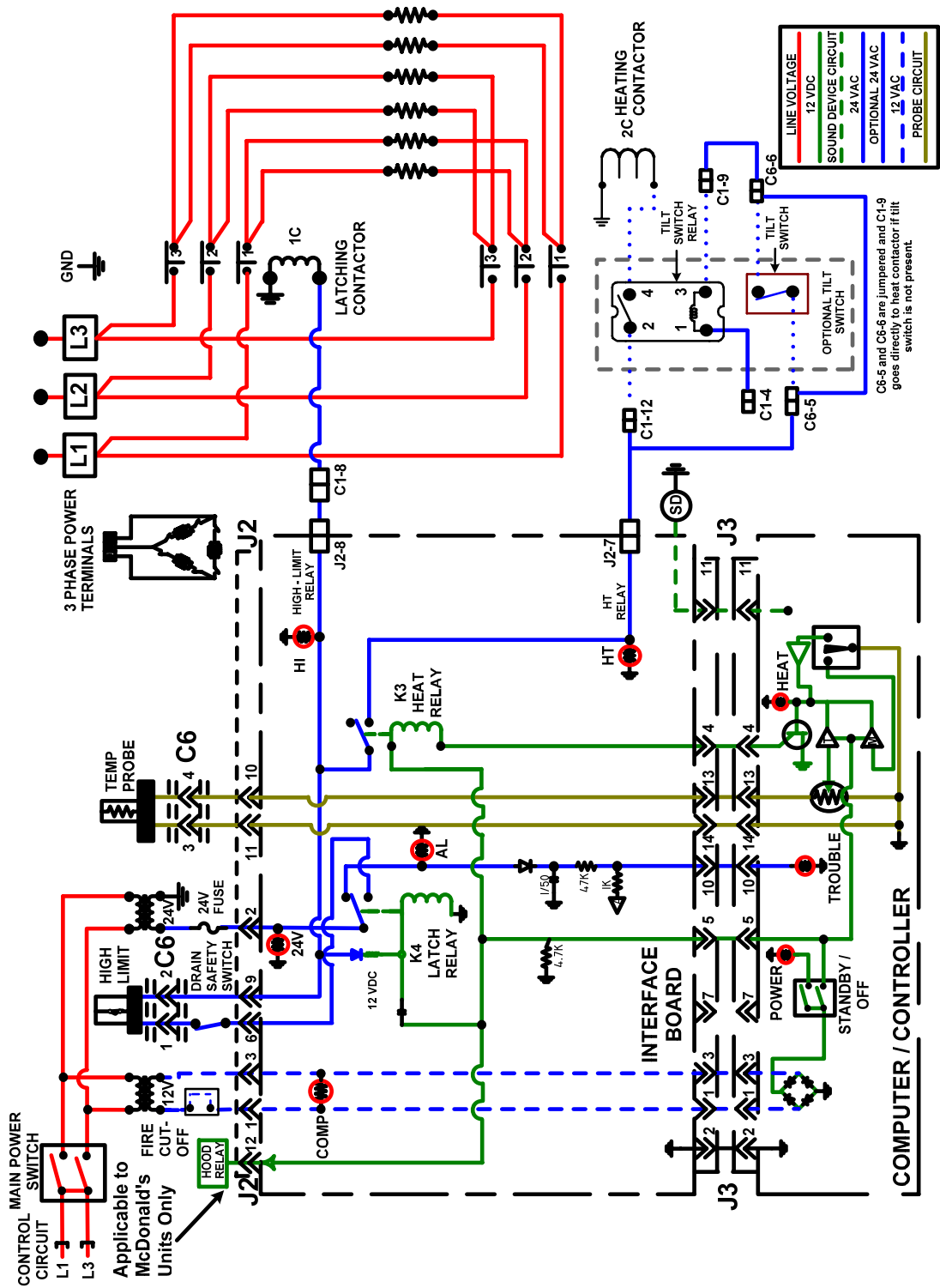

1.12.6 Simplified BIRE/MRE14 Series – Dual Vat Delta Wiring

ELECTRIC BIRE/MRE14 SERIES - DUAL-VAT

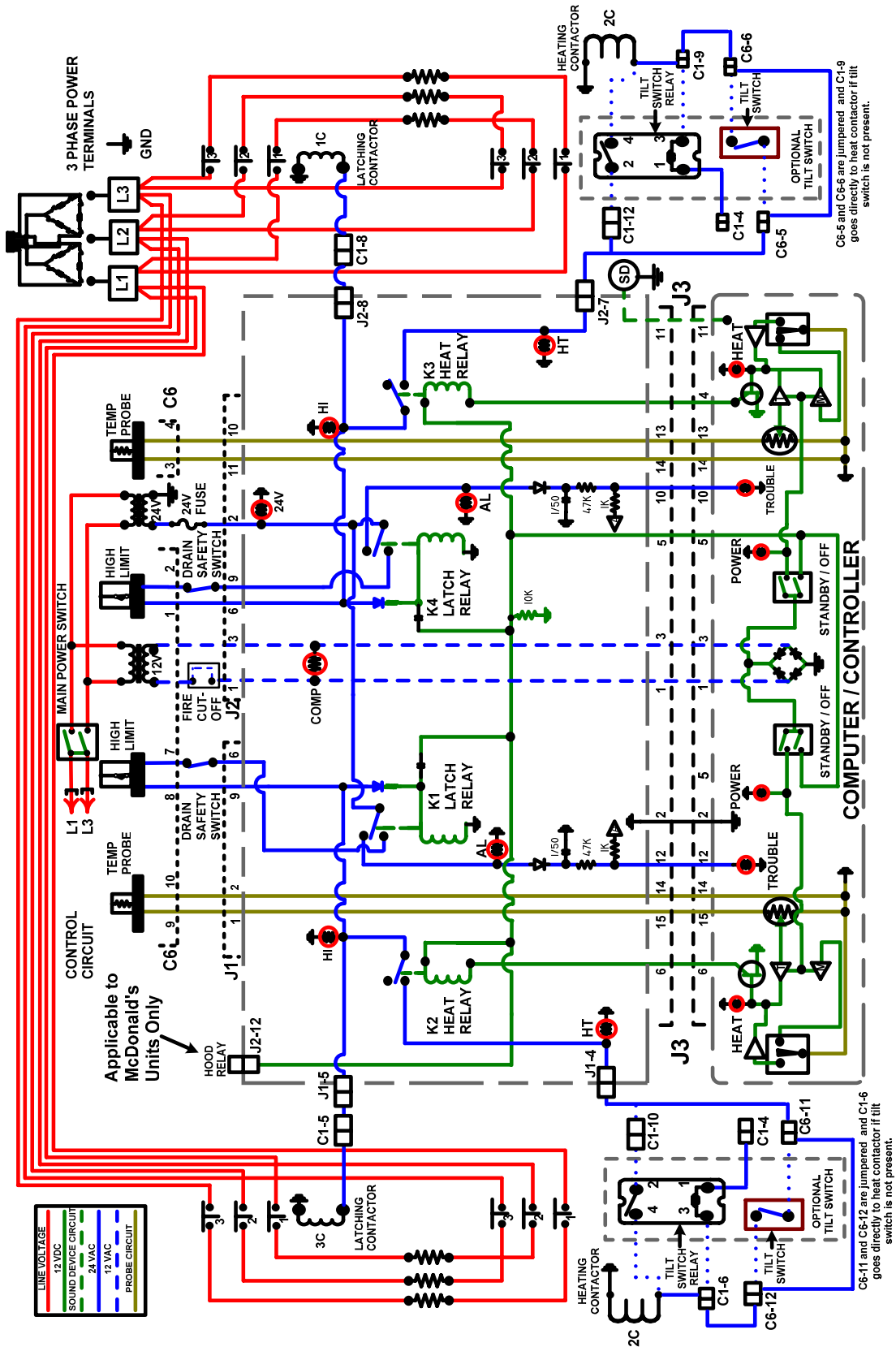

1.12.7 Simplified BIRE/MRE14 Series – Full Vat Wiring EXPORT WYE

ELECTRIC BIRE/MRE14 SERIES - FULL-VAT EXPORT WYE

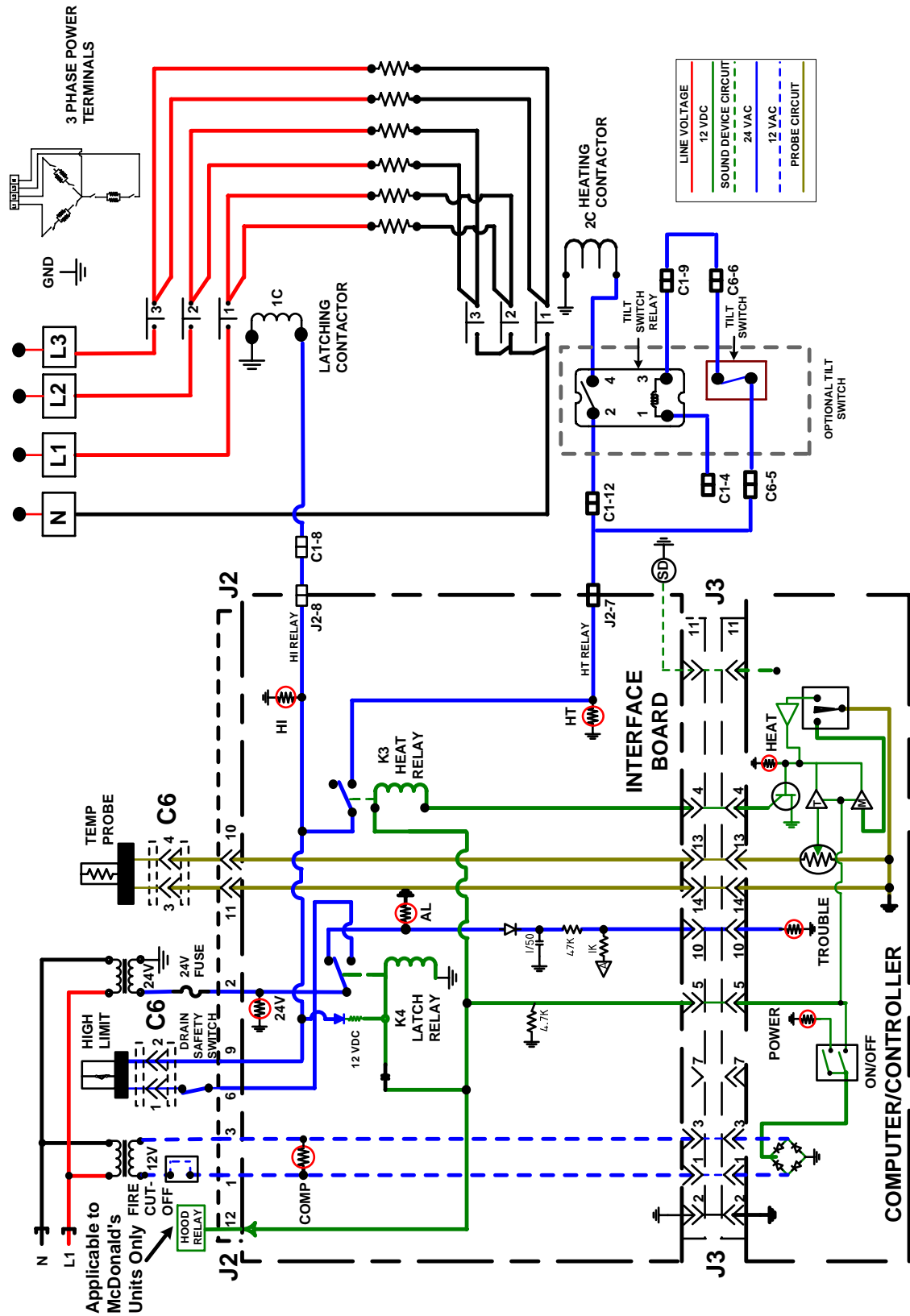

1.12.8 Simplified BIRE/MRE14 Series – Dual Vat Wiring EXPORT WYE

ELECTRIC BIRE/MRE14 SERIES - DUAL-VAT EXPORT WYE

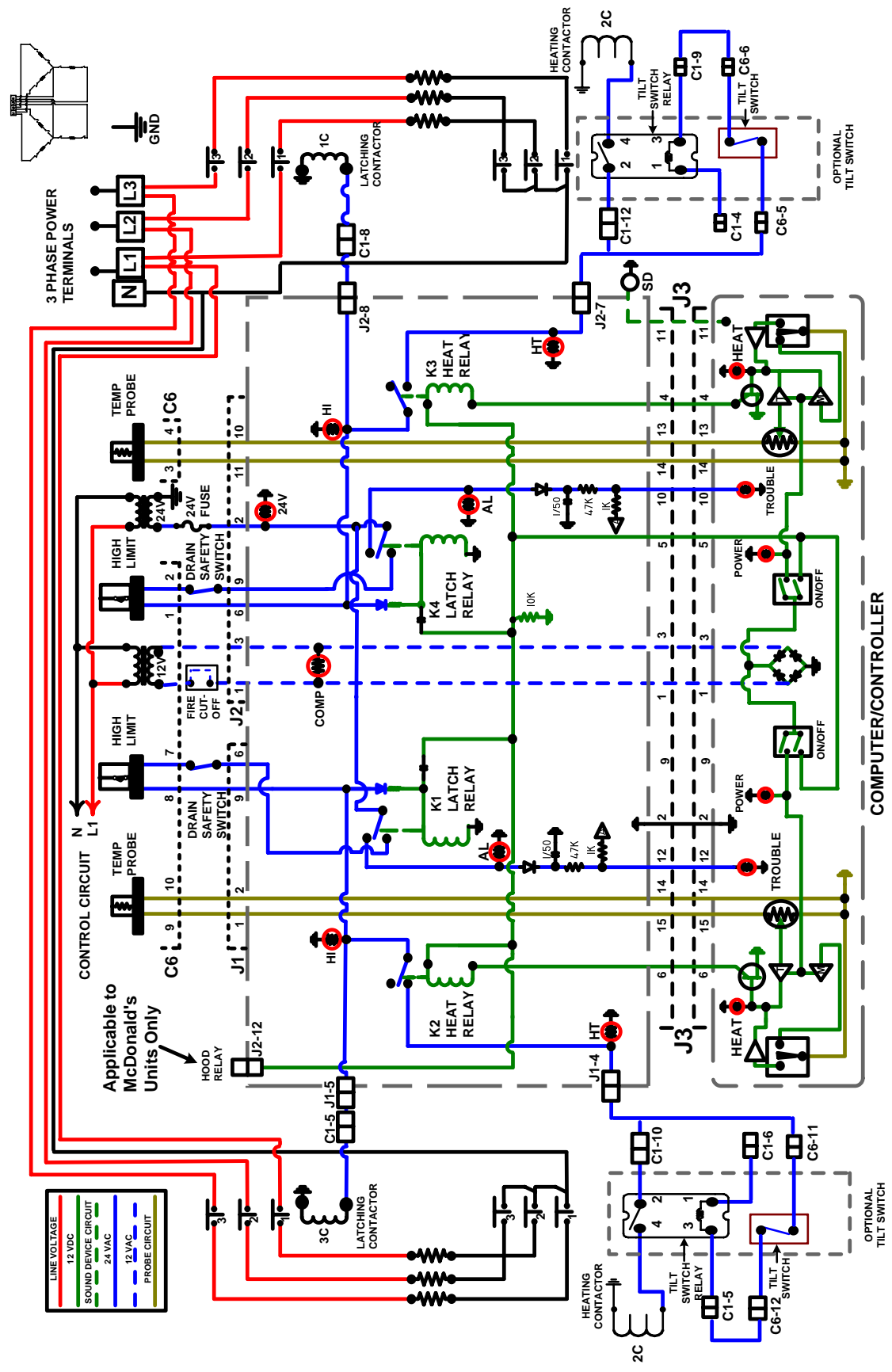

1.12.9 Simplified BIRE/MRE14 Series – Full Vat Wiring EPRI

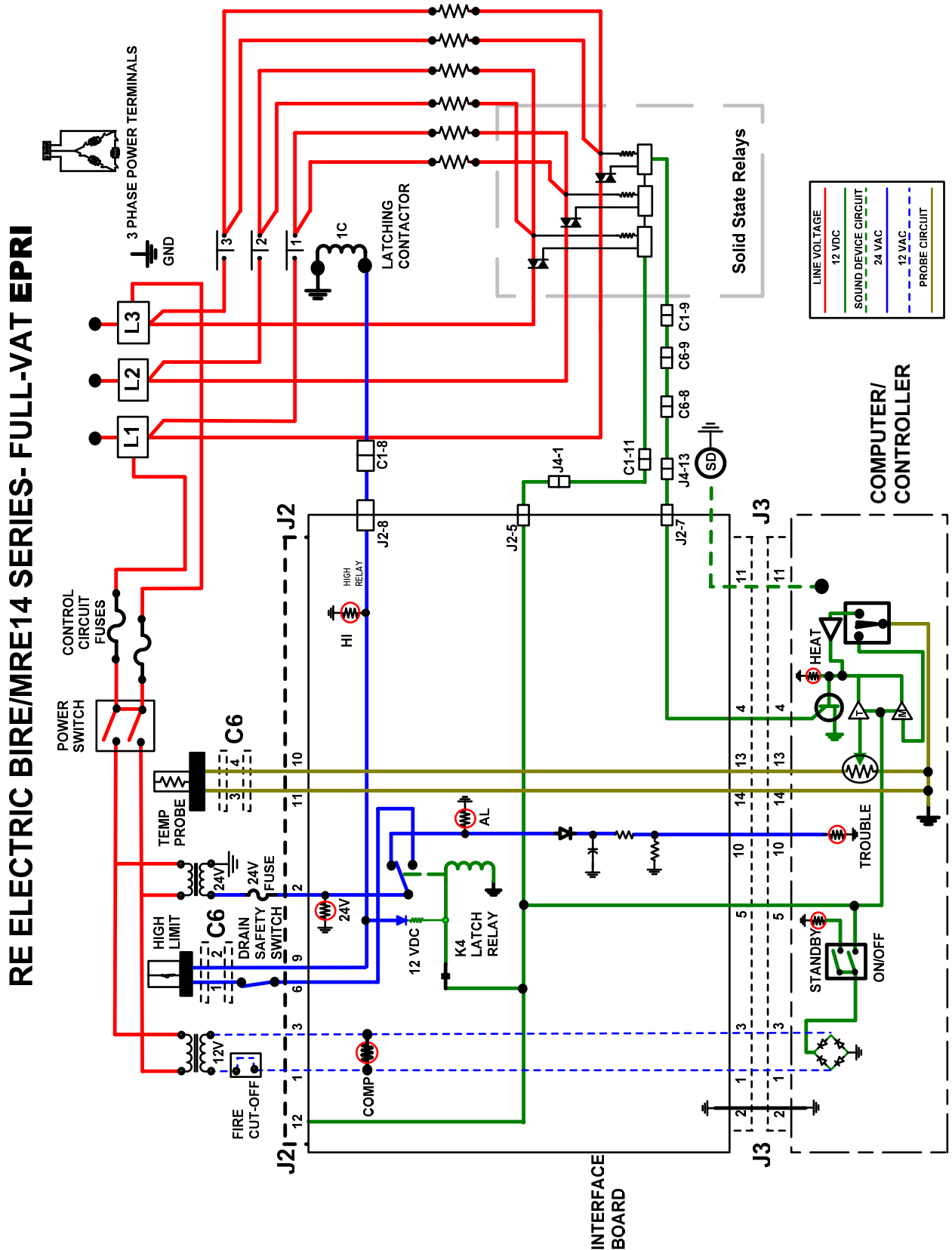

1.12.10 Simplified BIRE/MRE14 Series – Full Vat Wiring EPRI EXPORT WYE

ELECTRIC BIRE/MRE14 SERIES-FULL-VAT EPRI WYE

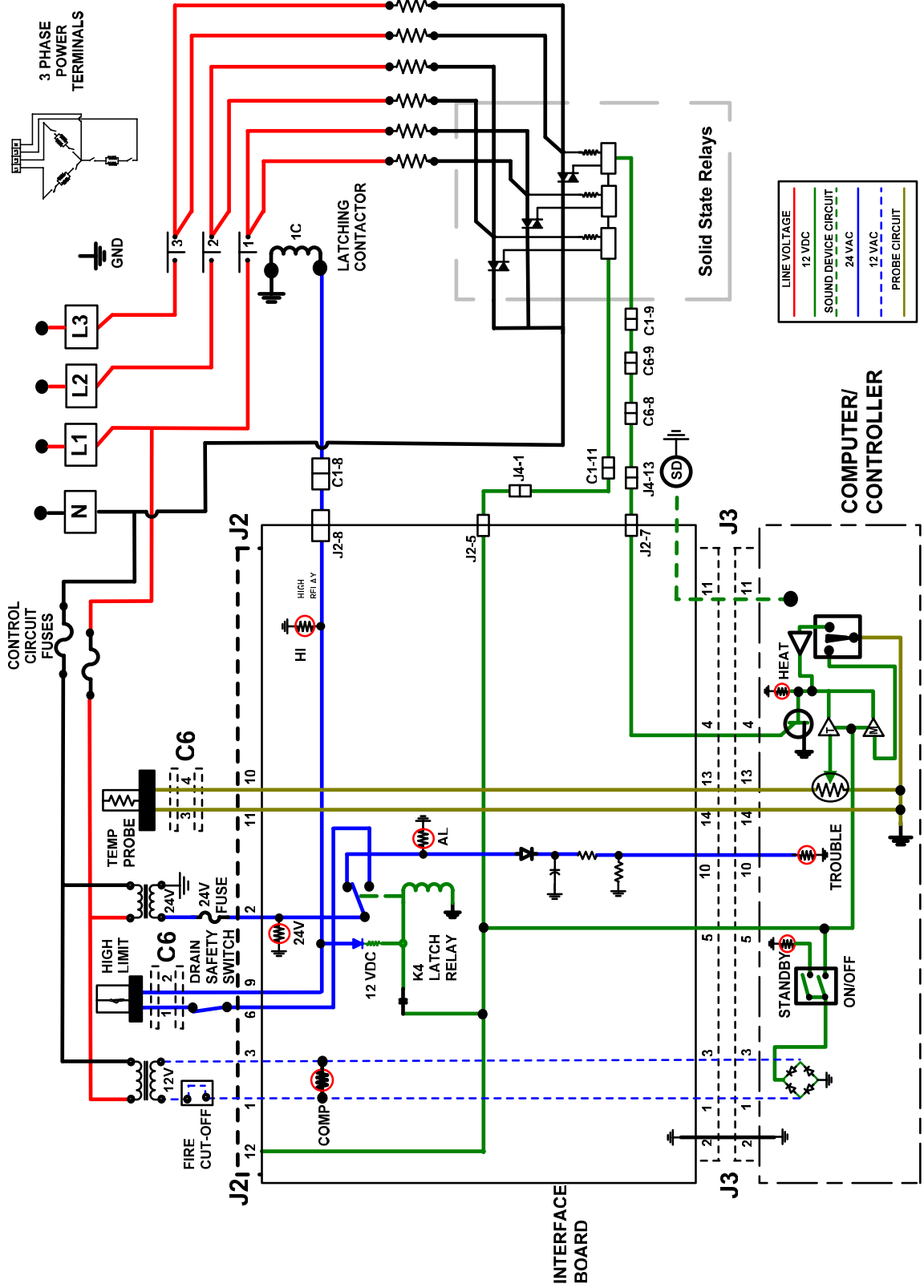

BIRE14/MRE14 SERIES ELECTRIC FRYERS

CHAPTER 2: PARTS LIST

2.1 Accessories

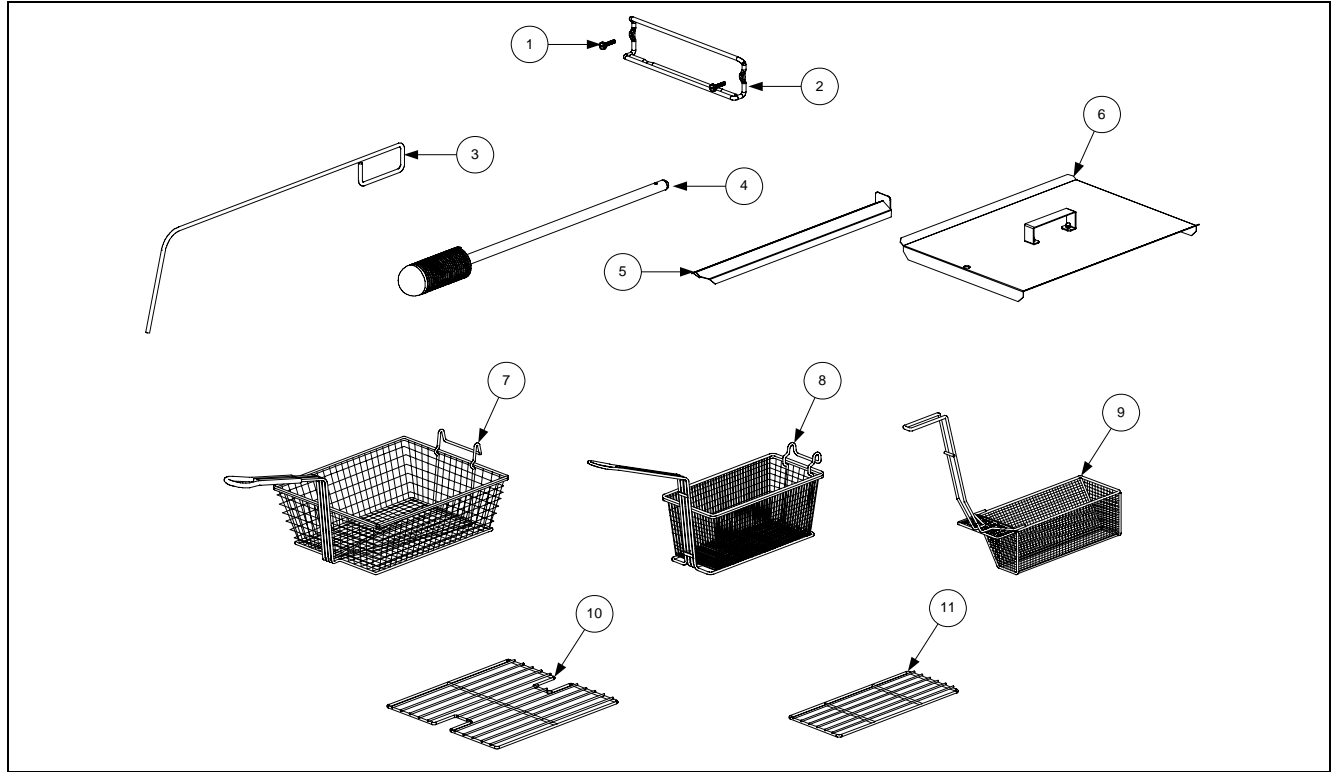

ITEM	PART #	COMPONENT
1	809-0171	Thumbscrew, ¼ -20 X 1⅜-inch
2	810-2793	Hanger, Wireform Basket
*	809-0921	Spacer, Basket Hanger
3	803-0197	Cleanout Rod, 27-inch
4	803-0209	Brush, Frypot
5	823-5772	Connecting Strip, Frypot
6	806-3068	Cover, Full-Vat Frypot
*	806-3071	Cover, Dual-Vat Frypot
7	803-0099	Basket, Full-Vat
8	803-0271	Basket, Dual-Vat (Twin)
9	803-0122	Sediment Tray, Left Dual-Vat
*	803-0123	Sediment Tray, Right Dual-Vat
*	803-0113	Sediment Tray, Full-Vat
10	803-0132	Rack, Full-Vat Basket Support
11	803-0106	Rack, Dual-Vat Basket Support
*	803-0002	Powder, Filter (80- 1-Cup Applications)
*	803-0046	Cup, Plastic Measuring
*	803-0170	Pack, 100-Sheet Filter Paper

*Not illustrated.

2.2 Cabinetry

2.2.1 Back Panels, Control Panel Frames, Doors, Sides, Tilt Housings, and Top Caps

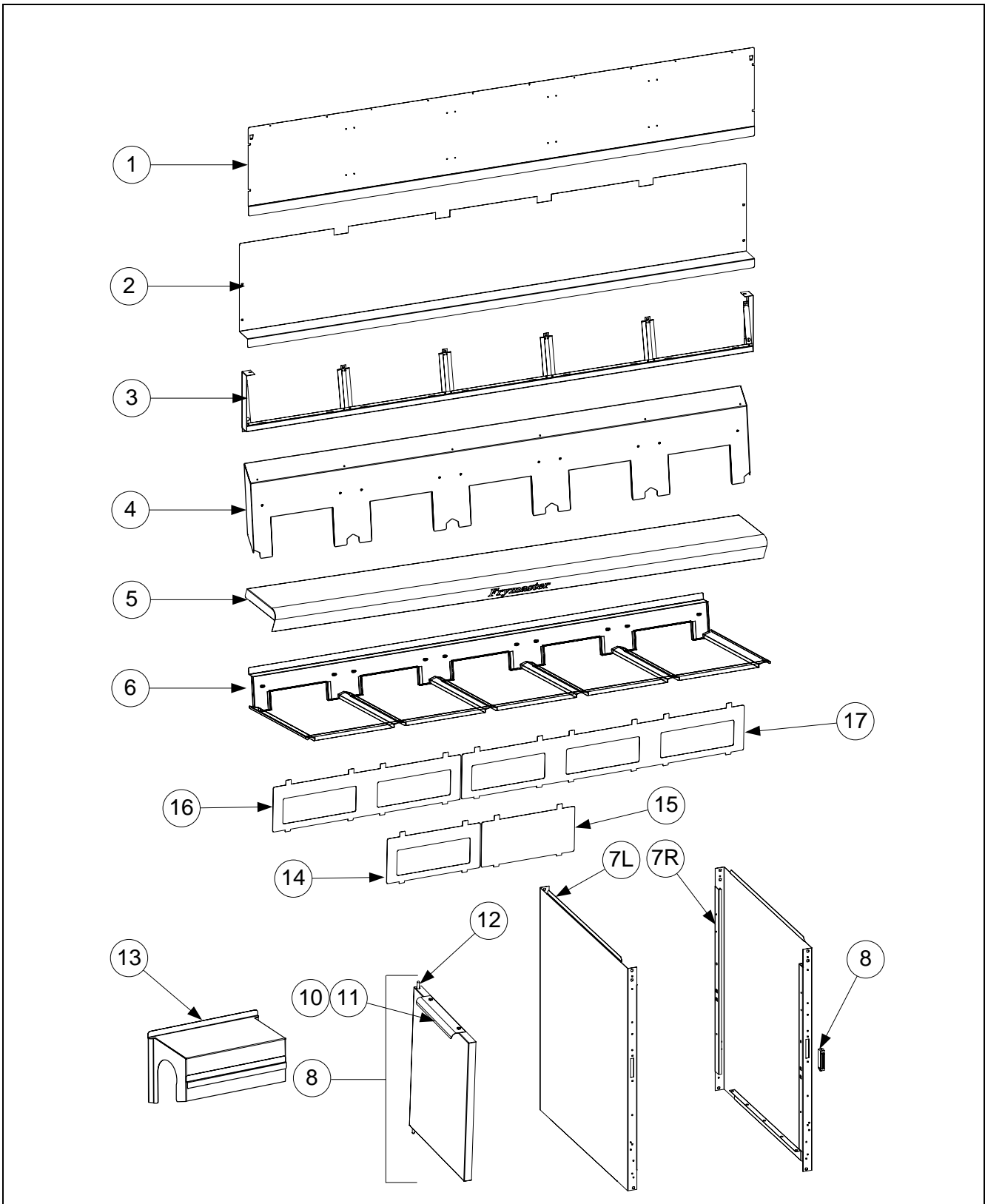

2.2.1 Back Panels, Control Panel Frames, Doors, Sides, Tilt Housings, and Top Caps

ITEM	PART #	COMPONENT
1		Back Panel, Upper (Panel for five station fryer shown)
	220-0421	Single Station Fryer
	220-0419	Two Station Fryer
	220-0423	Three Station Fryer
	220-0425	Four Station Fryer
	220-0611	Five Station Fryer
2		Back Panel, Center (Panel for five station fryer shown)
	220-0501	Single Station Fryer
	220-0487	Two Station Fryer
	220-0491	Three Station Fryer
	220-0499	Four Station Fryer
	220-0616	Five Station Fryer
3		Frame, Control Panel (Frame for five station fryer shown)
	106-5016	Single Station Fryer
	106-5221	Two Station Fryer
	106-5018	Three Station Fryer
	106-5019	Four Station Fryer
	106-5020	Five Station Fryer
4		Tilt Housing (Housing for five station fryer shown)
	823-5402	Single Station, S/S (<i>use 823-5564 for Aluminized Steel</i>)
	823-5360	Two Station, S/S (<i>use 823-5570 for Aluminized Steel</i>)
	823-5492	Three Station, S/S (<i>use 823-5573 for Aluminized Steel</i>)
	823-5576	Four Station, S/S (<i>use 823-5577 for Aluminized Steel</i>)
	823-5578	Five Station, S/S (<i>use 823-5579 for Aluminized Steel</i>)
5		Top Cap (Top cap for five station fryer shown)
	106-5195	Single Station (<i>Also requires four 809-0078 10-32 Nutserts</i>)
	106-5196	Two Station (<i>Also requires four 809-0078 10-32 Nutserts</i>)
	106-5197	Three Station (<i>Also requires six 809-0078 10-32 Nutserts</i>)
	106-5198	Four Station (<i>Also requires eight 809-0078 10-32 Nutserts</i>)
	106-5199	Five Station (<i>Also requires ten 809-0078 10-32 Nutserts</i>)
*	200-9614	Heat Shield Single Station
*	200-9610	Two Station (<i>Two are used on Four Station</i>) (<i>One used on Five station</i>)
*	200-9611	Three Station (<i>One used on Five Station</i>)
6		Cap-N-Splash
	823-5715	Single Station
	823-5708	Two Station
	823-5706	Three Station
	823-5710	Four Station
	823-5713	Five Station
7L	231-0323	Side, Standard Cabinet Left SS (use 221-0323 for Enameled Steel)
7R	232-0323	Side, Standard Cabinet Right SS (use 222-0323 for Enameled Steel)
8	810-1105	Magnet, Door
9	106-4397	Door, Left or Right (Left shown – move handle to bottom for right)
10	809-0266	Screw, #10 X ½-inch Phillips Truss Head
11	210-9739	Handle, Eurolook Door
12	106-4067	Pin Assembly, Door
*	810-0275	Spring, Door Pin
*	809-0970	Retaining Ring
13	823-5440	Cove, Element Tilt Housing
14	210-5046	Bezel, One-Controller
15	210-5623	Bezel, Blank
16	210-5819	Bezel, Two-Controller
17	210-6698	Bezel, Three-Controller

* Not illustrated.

2.2.2 Cabinets, Bases, Braces, and Associated Parts

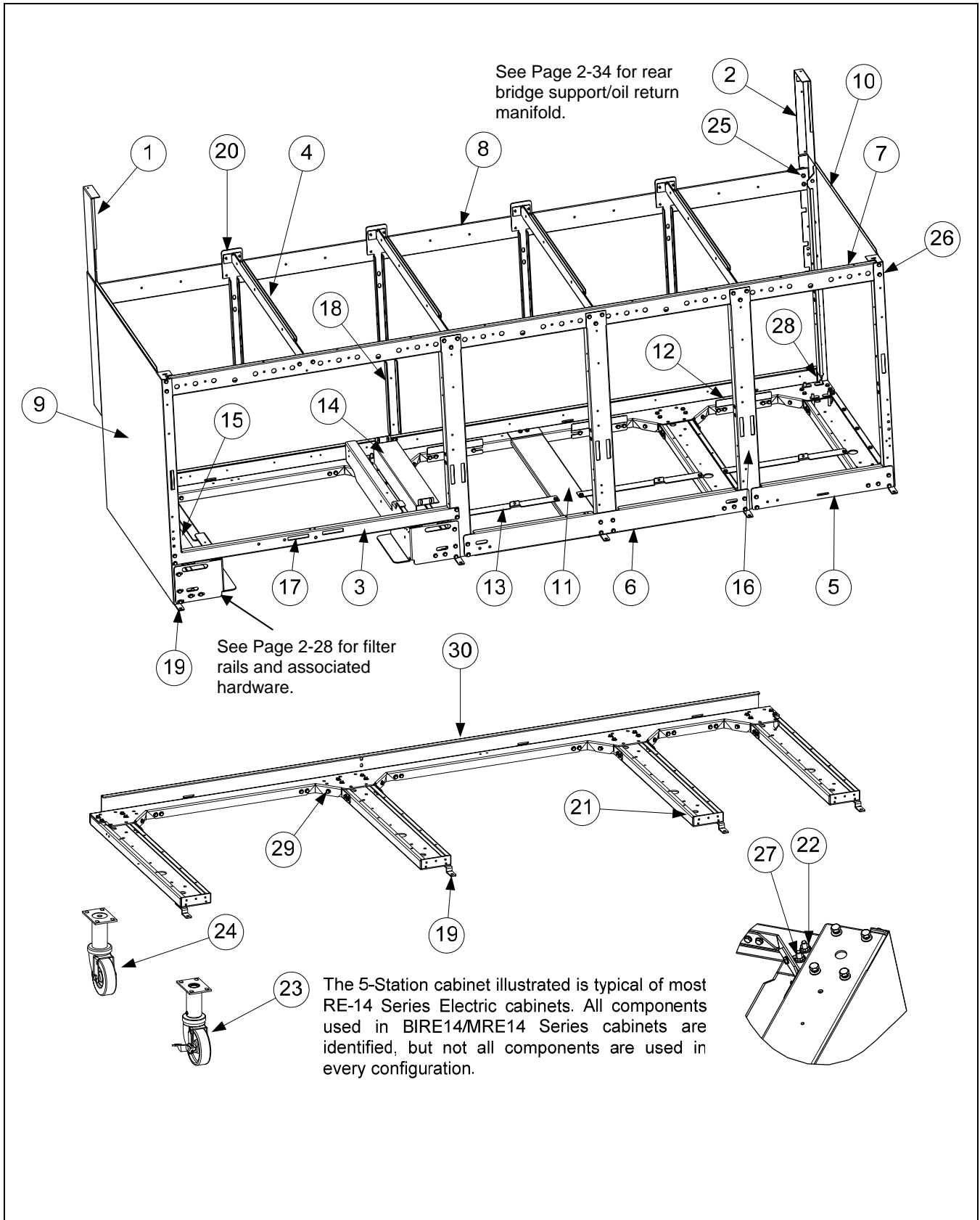

2.2.2 Cabinets, Bases, Braces, and Associated Parts cont.

ITEM	PART #	COMPONENT
1	106-3828	Upright Assembly, Left
2	106-3829	Upright Assembly, Right
3	200-1651	Support, Cross Cabinet
4	200-1659	Divider, Cabinet
5	200-2293	Brace, Single Station Lower
6	200-3774	Brace, Double Station Lower
7		Brace, Front Horizontal
	200-7036	Single-Station Fryer (<i>use 220-0624 for Single-Station Lower Brace</i>)
	200-7037	Two-Station Fryer
	200-7038	Three-Station Fryer
	200-7039	Four-Station Fryer
	200-7040	Five-Station Fryer
8		Brace, Rear Horizontal
	200-5356	Single-Station Fryer
	200-2284	Two-Station Fryer
	200-2295	Three-Station Fryer
	200-2725	Four-Station Fryer
	200-3592	Five-Station Fryer
9	231-0323	Side, Cabinet LH S/S (<i>use 221-0323 for CRS</i>)
10	232-0323	Side, Cabinet RH S/S (<i>use 222-0323 for CRS</i>)
11	220-1100	Support, RE Bottom Contactor Box
12	220-1095	Support, RE Rear Contactor Box
13	220-1093	Brace, RE Front Contactor Box
*	220-1294	Brace, Contactor Box Single-Station Fryer Front
14	222-0610	Bracket, RH Contactor Box Mount
15	221-0610	Bracket, LH Contactor Box Mount
*	200-6498	Bridge, Contactor Box Single-Station Fryer
16	200-4424	Post, Door
17	810-2346	Magnet, Door
18	200-4786	Support, Oil Return Manifold
19	210-6862	Hinge, Door
20	824-1393	Bracket, Rear Support
21	824-4557	Channel, Base Side
*	222-0621	Channel, Base Right Side Single-Station Fryer
*	221-0621	Channel, Base Left Side Single-Station Fryer
22	809-0131	Bolt, 1/4-20 X 3/4-inch Hex Head (<i>also used w/Item 27 to mount filter rails</i>)
23	810-0326	Caster with Brake
24	810-0327	Caster without Brake
25	826-1376	Nut, 10-32 Keps Hex (Pkg. of 10)
26	826-1374	Screw, #10 X 1/2-inch Hex Washer Head (<i>primary cabinet screw</i>)(Pkg. of 25)
27	809-0417	Nut, 1/4-20 Hex Flange
28	809-0429	Bolt, 1/4-20 X 2-inch Hex Head
29	200-5417	Brace, Rear Channel Corner
30		Channel, Base Rear
	823-5589	Single-Station Fryer Base
	823-4558	Two-Station Fryer
	823-4560	Three-Station Fryer
	823-4561	Four-Station Fryer
	823-4562	Five-Station Fryer
*	810-3010	Leg, Single Fryer Single-Station Fryer
*	824-1705	Bridge, Pump/Motor Single-Station Fryer
*	809-0495	Nut, 1/4" - 20 Press

* Not illustrated.

2.3 Drain System Components

2.3.1 Drain Tube Sections and Associated Parts

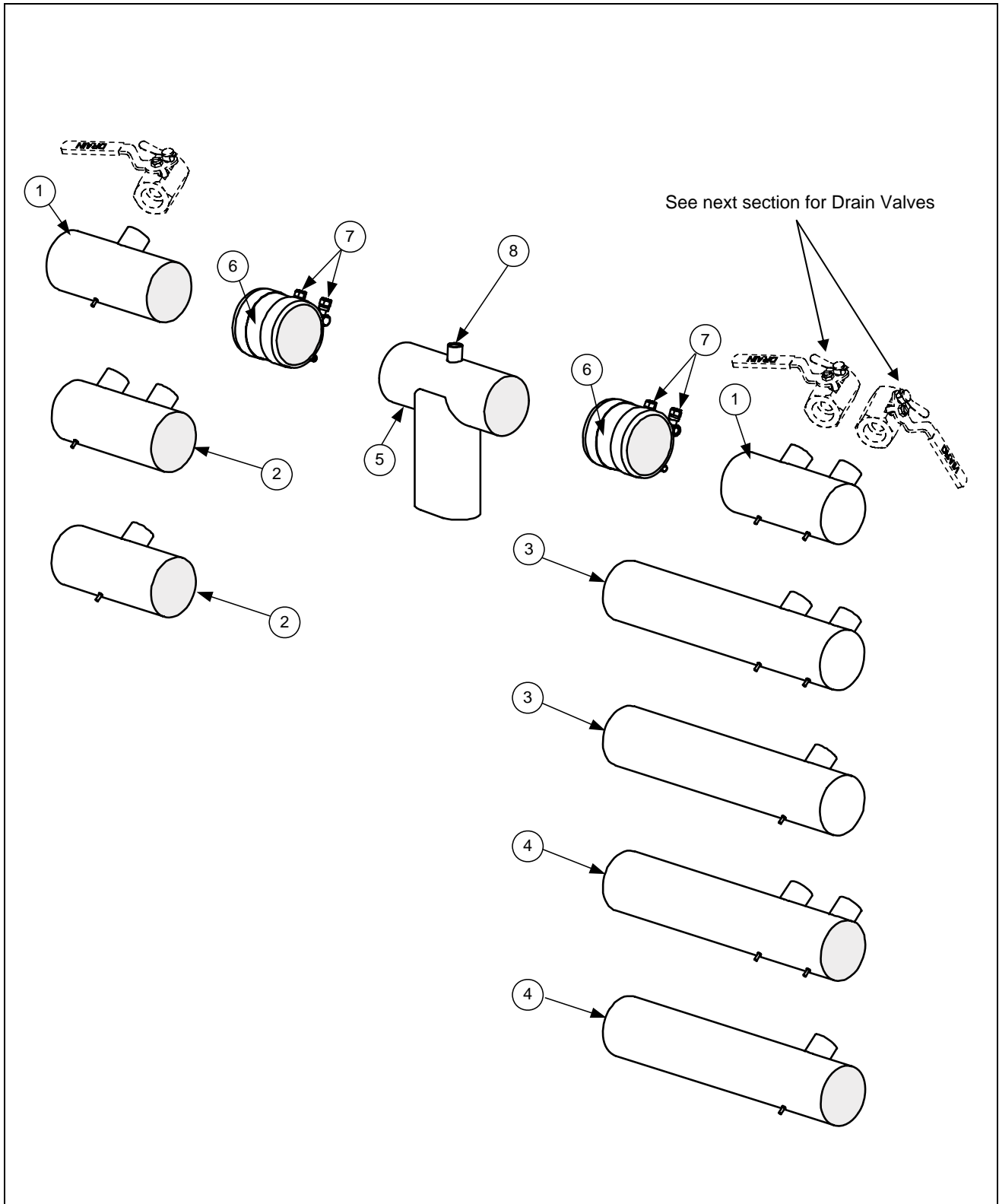

2.3.1 Drain Tube Sections and Associated Parts cont.

ITEM	PART#	COMPONENT
1		Drain Tube, Left/Right End Short
	823-4625	Full-Vat
	823-4624	Dual-Vat
2		Drain Tube, Left/Right Open Short
	823-4643	Full-Vat
	823-4642	Dual-Vat
3		Drain Tube, Right End Long
	823-4639	Full-Vat
	823-4638	Dual-Vat
4		Drain Tube, Left/Right Open Long
	823-4641	Full-Vat
	823-4640	Dual-Vat
5	823-4892	Drain Outlet
6	816-0625	Sleeve
7	809-0969	Clamp
*	816-0630	Vinyl Cap
8	810-2492	Fitting, Quick-Connect Straight (receives Teflon vent tube)
*	KIT6033	Kit, Round Drain Clamp (contains 2 of Item 7 and 1 of Item 6)
*	811-1071	Tube, Teflon Vent (sold by the foot)

* Not illustrated.

2.3.2 Drain Valves and Associated Parts (Units with Built-In Filtration)

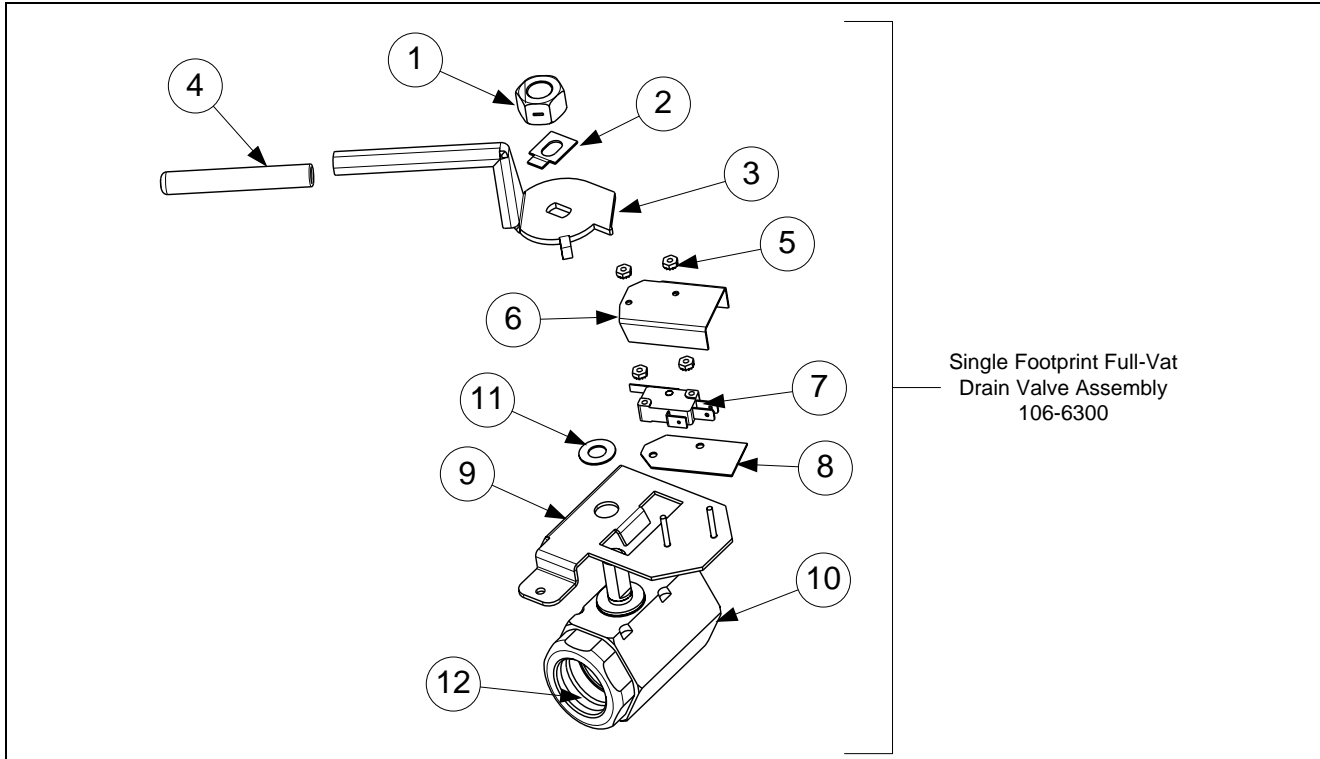

2.3.2 Drain Valves and Associated Parts (Units with Built-In Filtration) cont.

ITEM	PART #	COMPONENT
1	809-0540	Nut, 1/2-13 2-Way Hex Lock
2	900-2936	Retainer, Full-Vat Nut Drain Valve
3	824-1602	Handle, Full-Vat Drain Valve
4	816-0639	Cap, Red Handle
5	809-0237	Nut, 4-40 Keps Hex
6	901-2348	Cover, Dual Vat Drain Safety Switch
7	807-2103	Microswitch, CE Straight Lever
8	816-0220	Insulation, Drain Safety Switch
9	106-5391	Bracket Assembly, Full-Vat Drain Safety Switch Single Footprint Only
10	810-1018	Valve, 1.25-inch Full-Vat Drain Single FP
11	810-1165	Washer, Teflon
12	816-0135	O-Ring

2.3.2 Drain Valves and Associated Parts (Units with Built-In Filtration) cont.

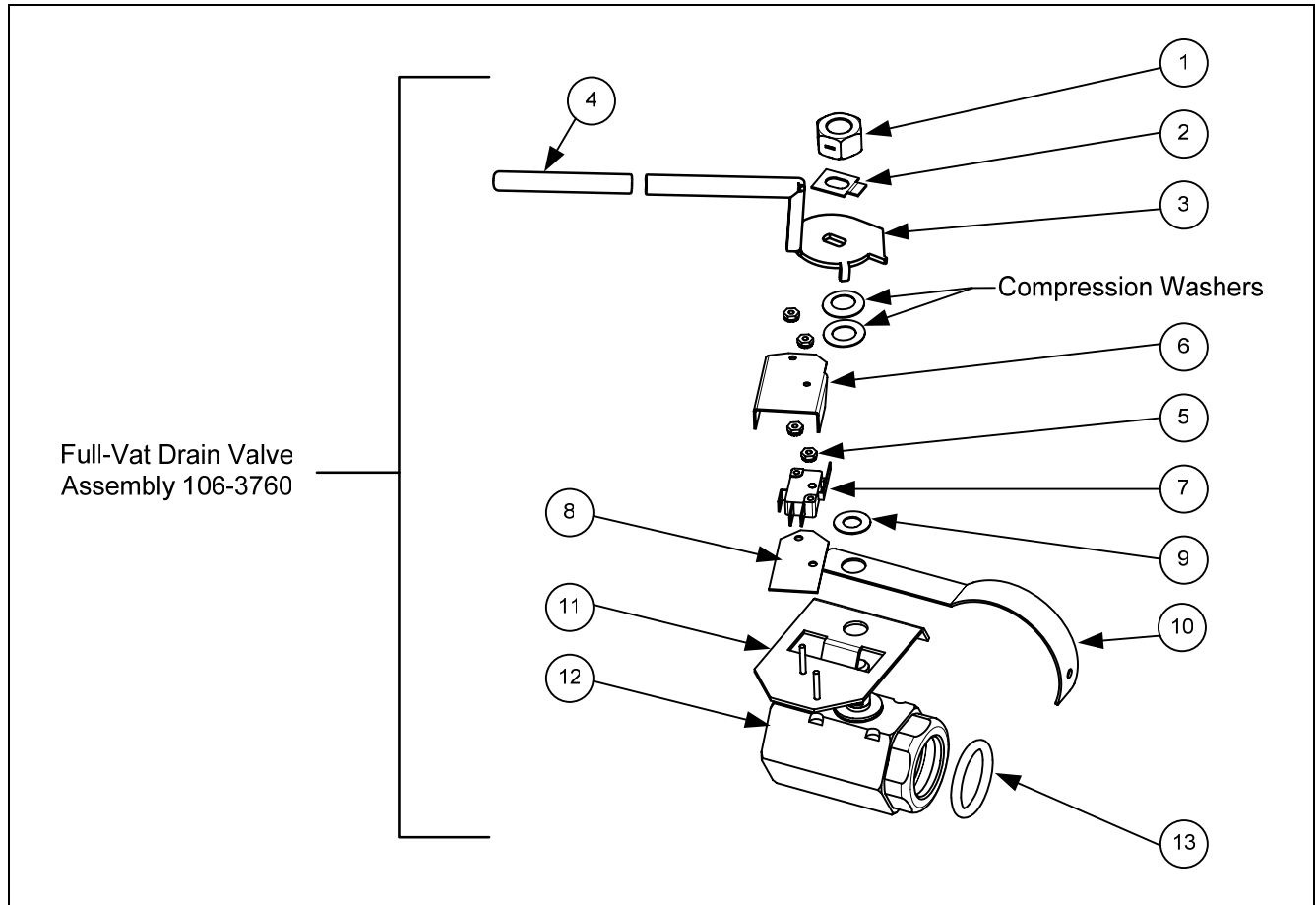

2.3.2 Drain Valves and Associated Parts (Units with Built-In Filtration) cont.

ITEM	PART #	COMPONENT
1	809-0540	Nut, ½-13 2-Way Hex Lock
2	900-2936	Retainer, Full-Vat Drain Valve Nut
3	824-1602	Handle, Full-Vat Drain Valve
4	816-0639	Cap, Red Handle
5	809-0237	Nut, 4-40 Keps Hex
6	901-2348	Cover, Dual Vat Drain Safety Switch
7	807-2103	Microswitch, CE Straight Lever
8	816-0220	Insulation, Drain Safety Switch
9	810-1165	Washer, Teflon Drain Valve
10	200-6496	Support, 3" Drain
11	806-8137	Bracket Assembly, Full-Vat Drain Safety Switch
12	810-1018	Valve, 1.25-inch Full-Vat Drain
13	816-0135	Round Drain O-Ring

2.3.2 Drain Valves and Associated Parts (Units with Built-In Filtration)

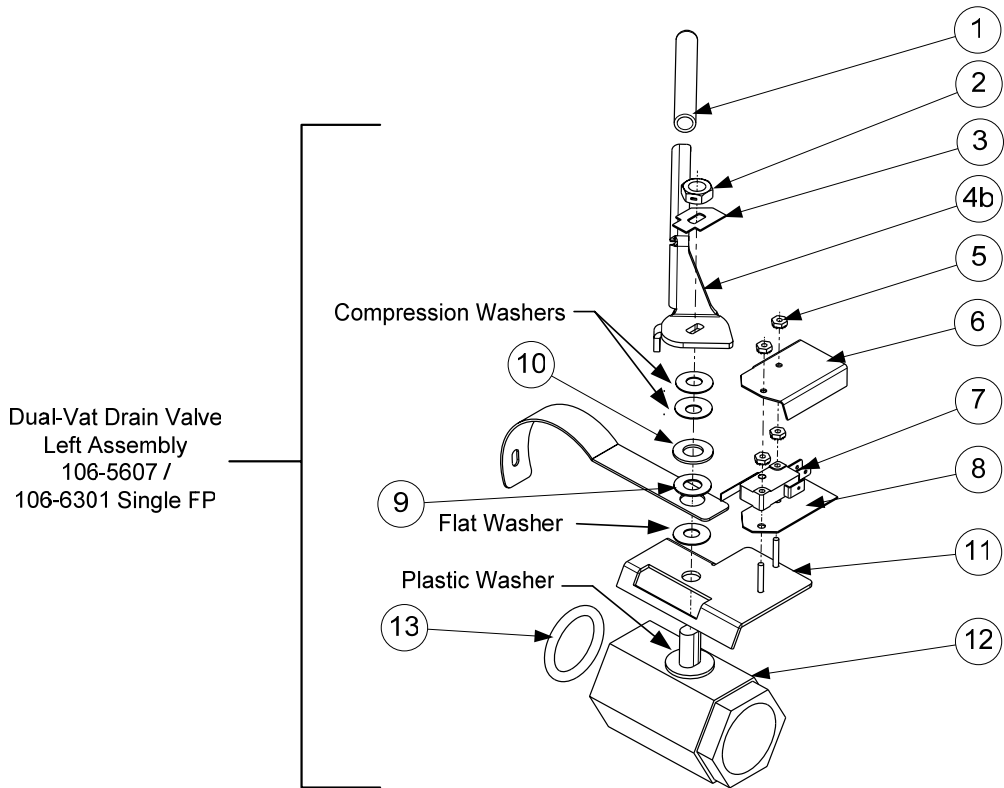
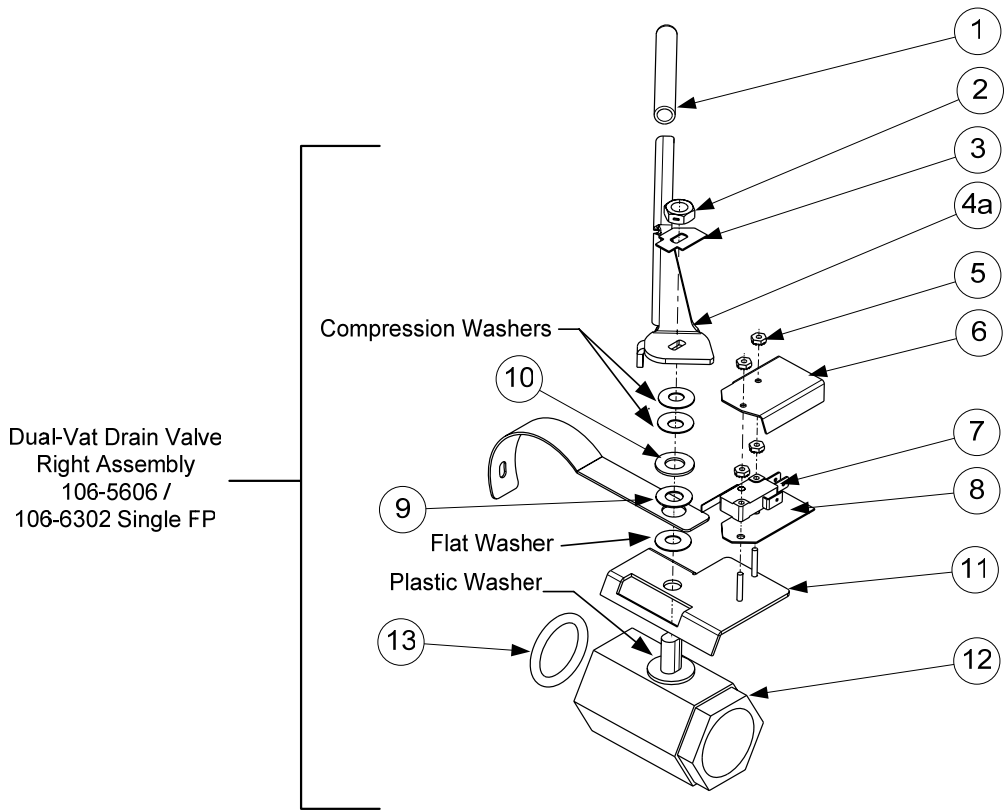

2.3.2 Drain Valves and Associated Parts (Units with Built-In Filtration) cont.

ITEM	PART#	COMPONENT
1	816-0639	Cap, Drain Handle
2	809-0539	Nut, 3/8-16 2-Way Hex Lock
3	900-2934	Retainer, Dual-Vat Drain Valve Nut
4a	824-1636	Handle, Dual-Vat Right Drain Valve
4b	824-1637	Handle, Dual-Vat Left Drain Valve
5	809-0237	Nut, 4-40 Keps Hex
6	901-2348	Cover, Dual Vat Drain Safety Switch
7	807-2103	Microswitch, CE Straight Lever
8	816-0220	Insulation, Drain Safety Switch
9	810-1165	Washer, Teflon Drain Valve
10	809-0196	Washer, 3/8-inch Flat
11	106-2671	Bracket Assembly, Dual-Vat Drain Safety Switch
	106-6304	Bracket Assembly, Dual-Vat Drain Safety Switch Single Footprint Only
12	810-1114	Valve, 1-inch Dual-Vat Drain
13	816-0135	Round Drain O-Ring
*	823-5592	Tube, Drain Single-Station Only with Filter

*Not illustrated.

2.3.3 Drain Valves and Associated Parts (Units without Built-In Filtration)

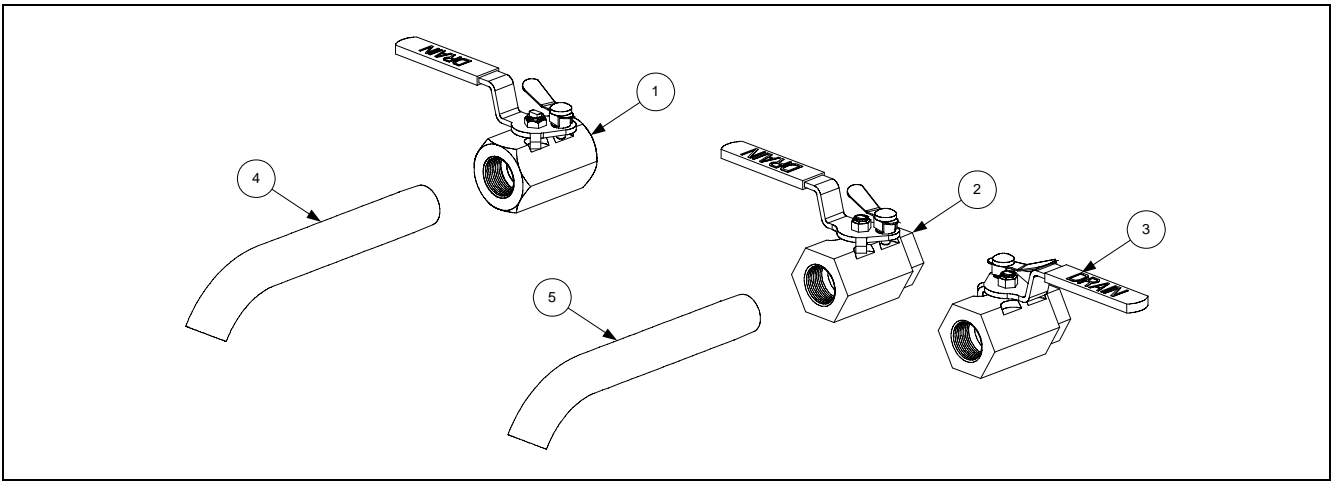

ITEM	PART #	COMPONENT
1	810-1569	Valve, 1.25-inch Non-Filter Full-Vat Drain
2	806-7915SP	Valve, 1-inch Non-Filter Dual-Vat Left Drain
3	806-7916SP	Valve, 1-inch Non-Filter Dual-Vat Right Drain
4	812-1226	Drain Extension, 1.25-inch
5	812-1227	Drain Extension, 1-inch

2.4 Electronics and Wiring Components

2.4.1 Component Boxes

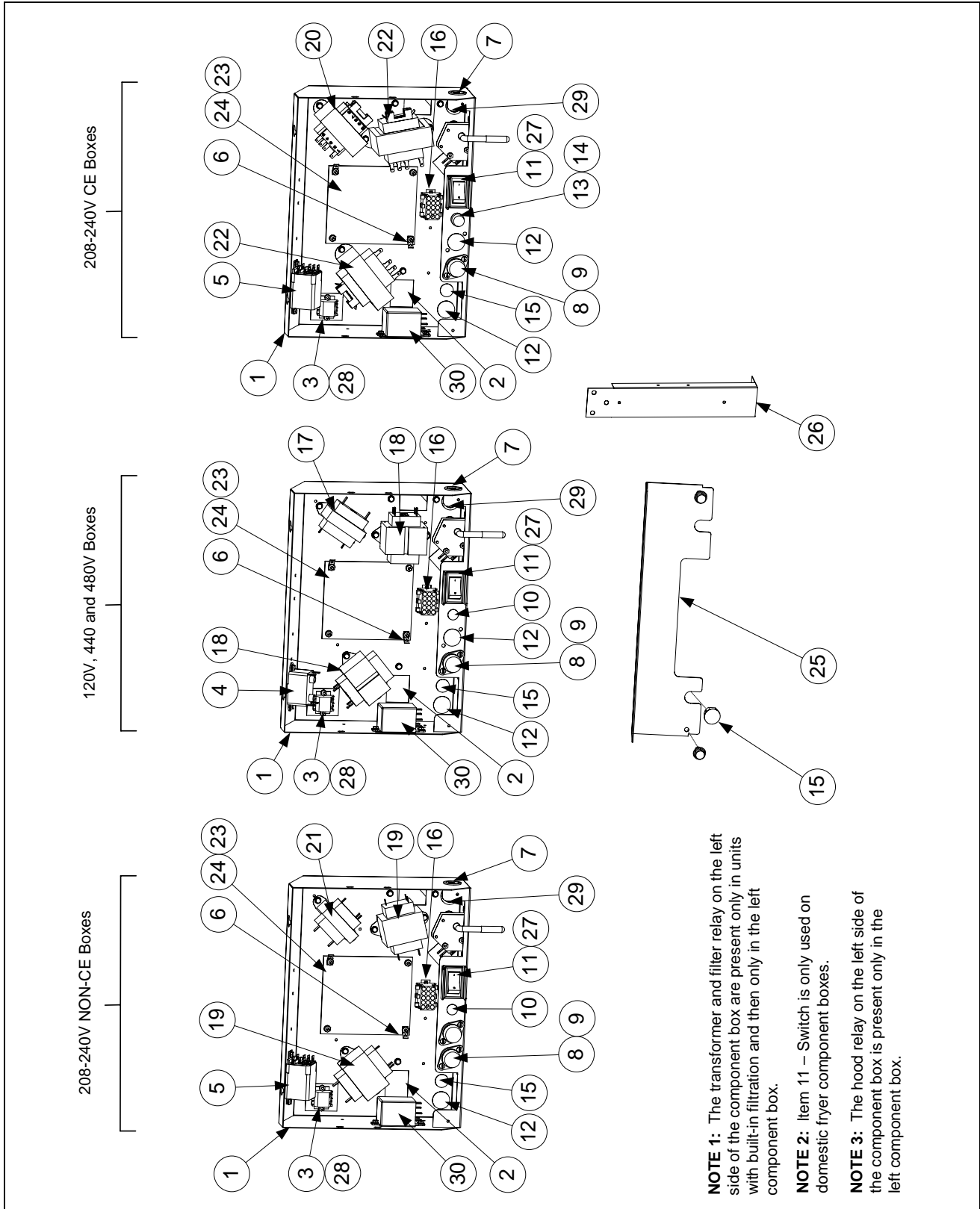

2.4.1 Component Boxes cont.

ITEM	PART #	COMPONENT
1	106-5592	Box Assembly, Component
2	200-3300	Bracket, Component Box Strain Relief
3	806-9495SP	Terminal Block
4	807-0012	Relay, Filter 18 Amp 1/3 HP 24V
5	807-0670	Relay, Filter Mintex DPDT 24V
6	807-0037	Terminal, 1/4-inch Push-on
7	807-0121	Bushing, Heyco Plastic AB-625-500
8	807-0922	Holder, Buss Fuse HPS
9	807-2278	Fuse, 20 Amp
10	810-2446	Plug, Button .50 Heyco Double "D"
11	807-4036	Switch
	807-3575	Plug, Carling Switch Hole (<i>used on some models without a switch</i>)
12	807-1947	Plug, Button .875 Dome
13	807-1321	Holder, AGC Panel Mount 1/4" Fuse (<i>Some models use item 10 here.</i>)
14	807-1597	Fuse, 3 AMP Slow-Blow
15	810-2445	Plug, Button .625 Heyco Double "D"
16	106-5750	Harness Assembly, RE FV Control
	106-5751	Harness Assembly, RE DV Control
17	807-0855	Transformer, 100-120V/12V 20VA
18	807-0800	Transformer, 100-120V/24V 50VA Filter
19	807-0680	Transformer, 208-240V/24V 20VA Filter
20	807-2191	Transformer, 208-240V/12V 30VA
21	807-0979	Transformer, 208-240V/12V 43VA
22	807-2180	Transformer, 208-240V 50VA Filter
23	809-0349	Spacer, 4mm X 6mm Aluminum
24		Interface Board (<i>SMT interface boards do not have replaceable relays</i>)
	826-2260	Standard Full or Dual Vat Interface Board (<i>incl. SMT speaker harness</i>)
	826-2261	EPRI, Full- or Dual-Vat (<i>includes SMT speaker harness</i>)
*	807-3932	Relay, Latch/Heat 12VDC SPDT 12A Sealed (<i>SMT interface boards do not have replaceable relays</i>)
25	220-0565	Guard, Finger Domestic and Non-CE
	220-1061	Guard, Finger Non-Domestic and CE
26	200-6654	Brace, Component Box
27	230-0834	Guard, RE Box Switch
28	816-0217	Paper, Insulating Terminal Block
29	810-0045	Bushing, .875 Diameter 11/16"
30	807-2515	Relay, 120V SPDT 10A (<i>used in Canadian models only</i>)
*	826-2249	RE Hood/Ansul Interlock Kit (includes terminal block, wires and connectors)
*	807-3520	Speaker, 4-Watt
*	807-4330	Sound Device Adaptor Harness (SMT)

* Not illustrated.

2.4.2 Contactor Boxes

2.4.2.1 Left and Right Over the Filter Pan Contactor Box Configurations

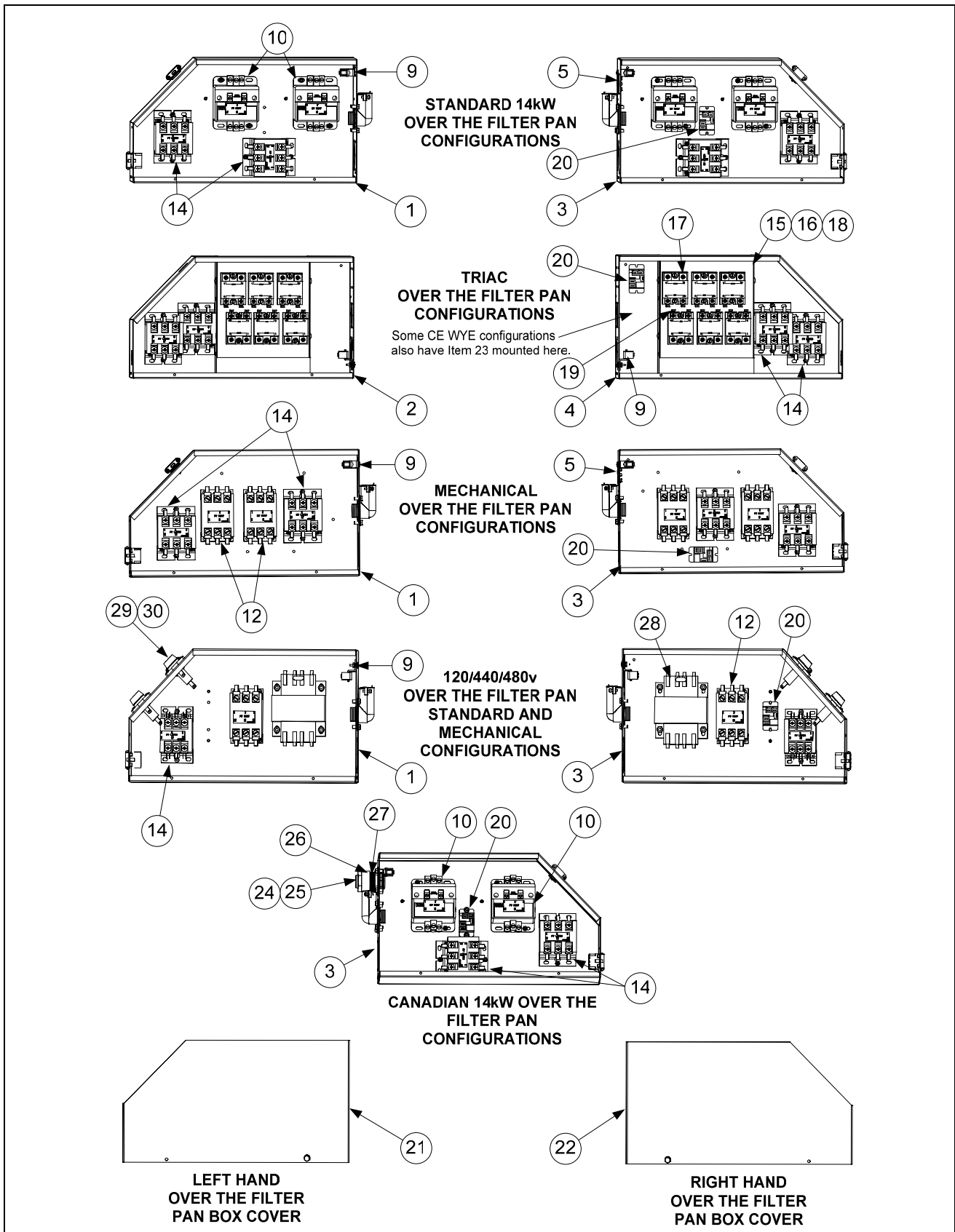

2.4.2.1 Left and Right Over the Filter Pan Contactor Box Configurations

NOTES: Left and right contactor box assemblies are mirror images of one another. With the exception of the box itself, all components of a left-hand assembly are the same as those in the corresponding right-hand assembly and vice versa except for the hood relay which occurs in the right or large box only. The configurations illustrated show all possible components, but a particular configuration may not have all the components shown.

ITEM	PART #	COMPONENT
1	106-5488	Box Assembly, Left Contactor (Over the Filter Pan)
2	823-5736	Box Assembly, Left Contactor EPRI (Over the Filter Pan)
3	106-5489	Box Assembly, Right Contactor (Over the Filter Pan)
4	823-5748	Box Assembly, Right Contactor EPRI (Over the Filter Pan)
5	810-2554	Plug, Cord Cutout 1.125 Button
6	807-1947	Plug, .875 Diameter Dome
7	221-0482	Cover, Left Hand Contactor Box
8	222-0482	Cover, Right Hand Contactor Box
9	807-0070	Terminal, Ground Lug
10	807-1071	Contactor, 24V 30 Amp Mercury
11	807-0884	Contactor, 24V 50 Amp Mercury
12	807-2284	Contactor, 24V 50 Amp Mechanical
13	807-2283	Contactor, 24V 63 Amp Mechanical
14	810-1202	Contactor, 24V 40 Amp Mechanical
15**	806-8674	Heatsink Assembly, DV Solid State Relay (See components below)
16**	806-8673	Heatsink Assembly, FV Solid State Relay (See components below)
		Components of Items 15 and 16
17	826-1562	Kit Relay, Solid State 40 Amp 280V with Heatsink
18	807-2749	Heatsink, Solid State
19	807-0037	Terminal, ¼-inch Push-on
20	807-1683	Relay, Hood 12VDC
21	221-0482	Cover, Left Contactor Box Top (Over the Filter Pan Box)
22	222-0482	Cover, Right Contactor Box Top (Over the Filter Pan Box)
23	106-6204	Filter Assembly, EPRI (<i>used in CE WYE-configured EPRI units only</i>)
24	807-4316	McDonald's Cordset, 120V 5-Wire
25	807-4317	McDonald's Cordset, Europe 3-Wire Single Phase
26	807-1560	Strain Relief
27	220-1102	Plate, MRE Control Cord Relief
28	807-0064	Transformer, 480V/120V 150VA
29	807-0922	Holder, Bus Fuse
30	807-2278	Fuse, 20 Amp
*	221-0610	Bracket, Left Hand Contactor Box Mounting
*	222-0610	Bracket, Right Hand Contactor Box Mounting
*	807-0012	Relay, Tilt Switch 18 Amp 1/3 HP 24 V Coil

* Not illustrated.

** Dual-vat assembly has six relays (826-1562); Full-vat assembly has three relays.

2.4.2.2 Large Center Contactor Box Configurations (Non-Filter, Not Over the Filter and Single Units)

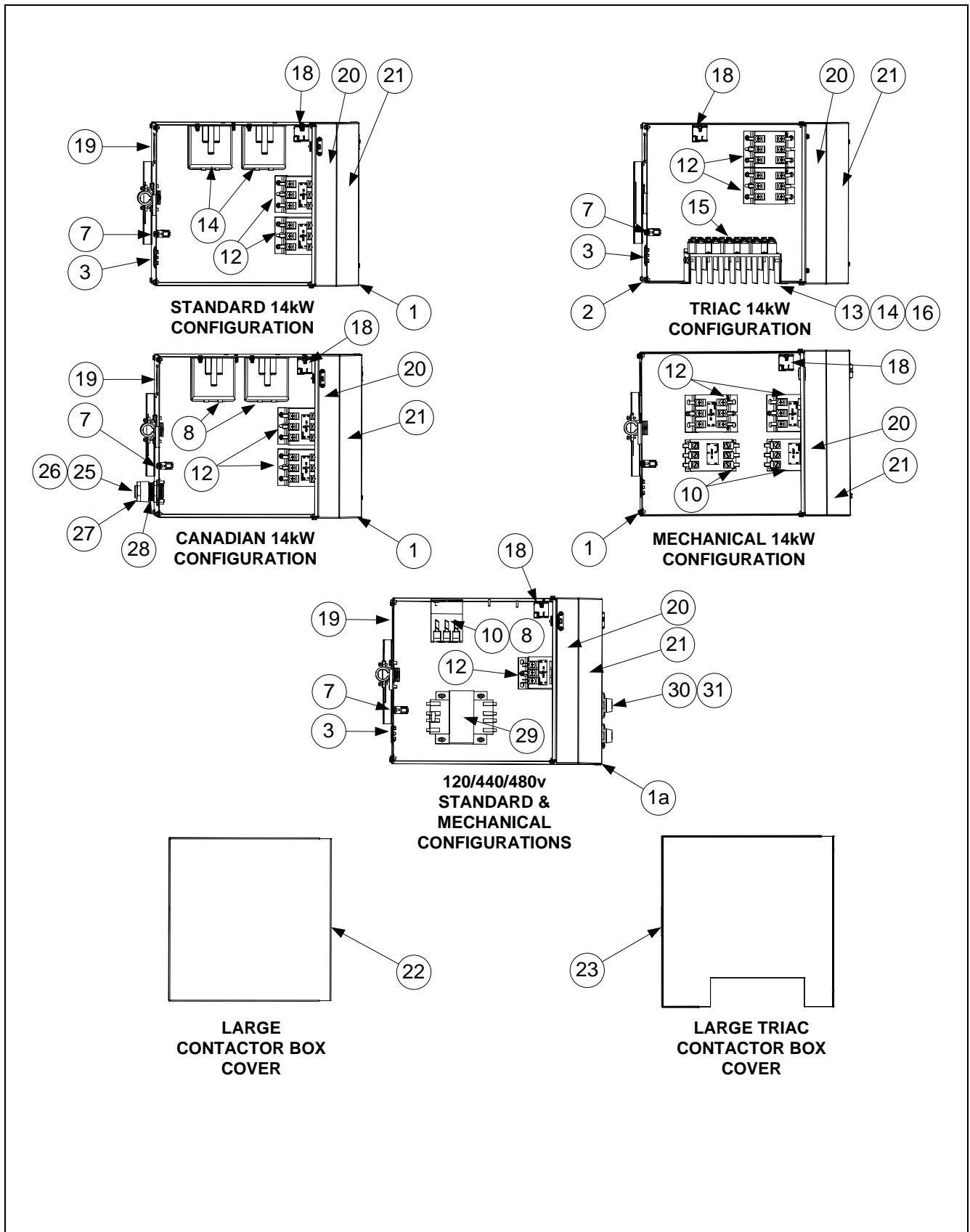

2.4.2.2 Large Center Contactor Box Configurations (Non-Filter, Not over the Filter and Single Units) cont.

ITEM	PART #	COMPONENT
1	106-6081	Box Assembly, Contactor (Non-Filter or Not Over the Filter Pan)
1a	106-6255	Box Assembly, Contactor (Non-Filter or Not Over the Filter Pan) <i>120/440/480V</i>
2	106-6173	Box Assembly, Contactor EPRI (Non-Filter or Not Over the Filter Pan)
*	106-6244	Box Assembly, Contactor Single-Station Fryer Only
3	810-2554	Plug, Cord Cutout 1.125 Button
4	807-1947	Plug, .875 Diameter Dome
5	221-0482	Cover, Left Hand Contactor Box
6	222-0482	Cover, Right Hand Contactor Box
7	807-0070	Terminal, Ground Lug
8	807-1071	Contactor, 24V 30 Amp Mercury
9	807-0884	Contactor, 24V 50 Amp Mercury
10	807-2284	Contactor, 24V 50 Amp Mechanical
11	807-2283	Contactor, 24V 63 Amp Mechanical
12	810-1202	Contactor, 600V 40 Amp 3-Pole
13**	806-8674	Heatsink Assembly, DV Solid State Relay (See components below)
14**	806-8673	Heatsink Assembly, FV Solid State Relay (See components below)
		Components of Items 13 and 14
15	826-1562	Kit Relay, Solid State 40 Amp 280V with Heatsink
16	807-2749	Heatsink, Solid State
17	807-0037	Terminal, ¼-inch Push-on
18	807-1683	Relay, Hood 12VDC
19	823-5729	Plate, Contactor Back Cordset
20	220-1087	Bracket, Box Connecting
21	220-1088	Cover, Contactor Box Front
22	220-1089	Cover, Contactor Box Top (Non-Filter or Not Over the Filter Pan)
*	220-1175	Cover, Contactor Box Top Full Vat Single-Station Fryer Only
*	220-1373	Cover, Contactor Box Top Dual Vat Single-Station Fryer Only
23	220-1152	Cover, Contactor Box Top EPRI (Non-Filter or Not Over the Filter Pan)
24	106-6204	Filter Assembly, EPRI (<i>used in CE WYE-configured EPRI units only</i>)
25	807-4316	McDonald's Cordset, 120V 5-wire
26	807-4317	McDonald's Cordset, Europe 120V 3-wire Single Phase
27	807-1560	Strain Relief
28	220-1102	Plate, Control Cord Relief
29	807-0064	Transformer, 480V/120V 150VA
30	807-0922	Holder, Bus Fuse
31	807-2278	Fuse, 20 Amp
*	807-0012	Relay, Tilt Switch 18 Amp 1/3 HP 24 V Coil

* Not illustrated.

** Dual-vat assembly has six relays (826-1562); full-vat assembly has three relays.

2.4.3 Terminal Blocks

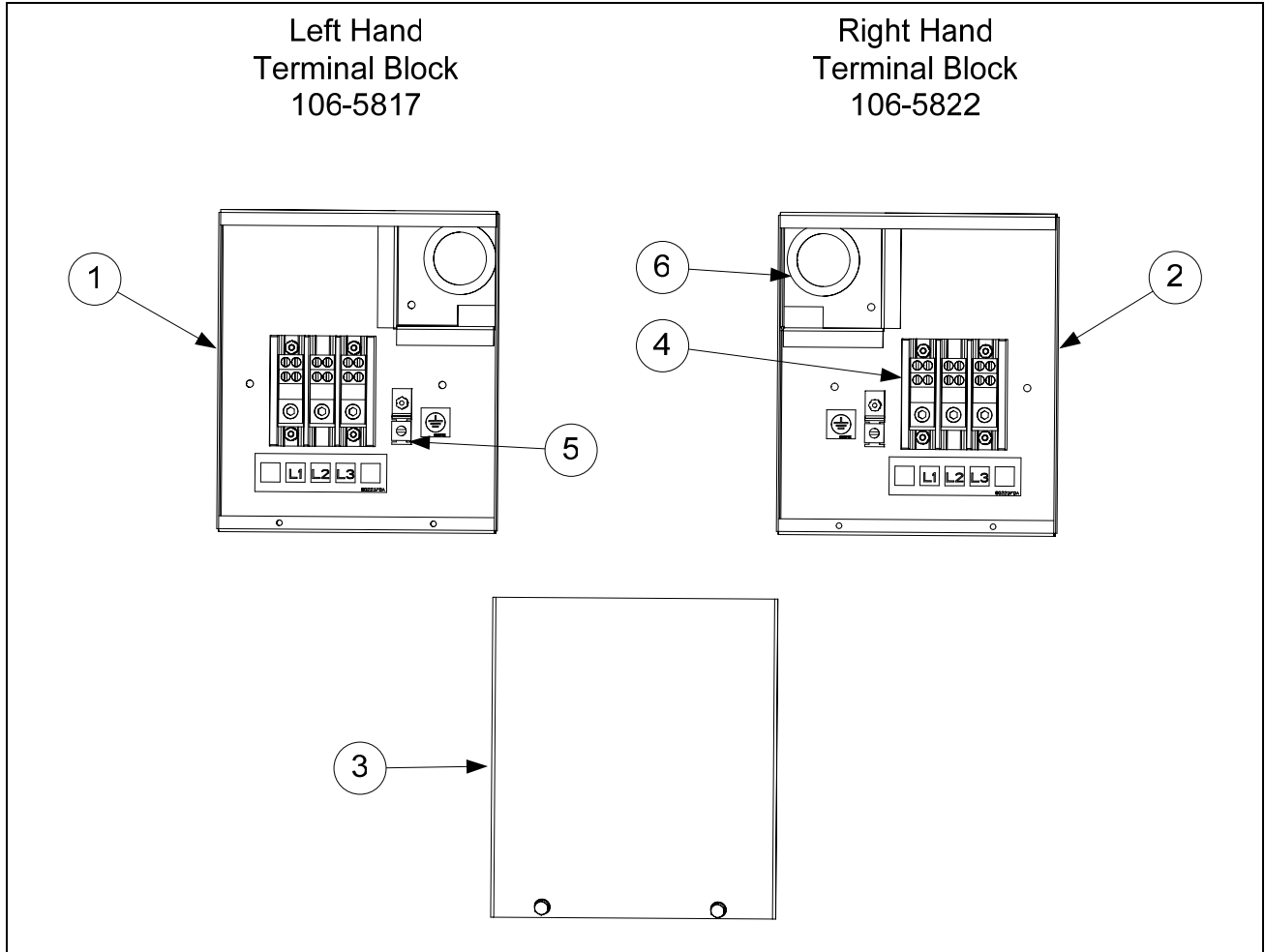

ITEM	PART #	COMPONENT
1	823-5631	Box, LH Rear Terminal Block
2	823-5632	Box, RH Rear Terminal Block
3	220-0801	Cover, Rear Terminal Block Box
4	807-3970	Block, 3 Pole 600V 175A
5	807-0070	Terminal, Ground Lug
6	807-0128	Bushing, Insulating Heyco

2.4.4 Heating Element Assemblies and Associated Parts

2.4.4.1 Element Assemblies and Hardware

FULL-VAT ELEMENT ASSEMBLY

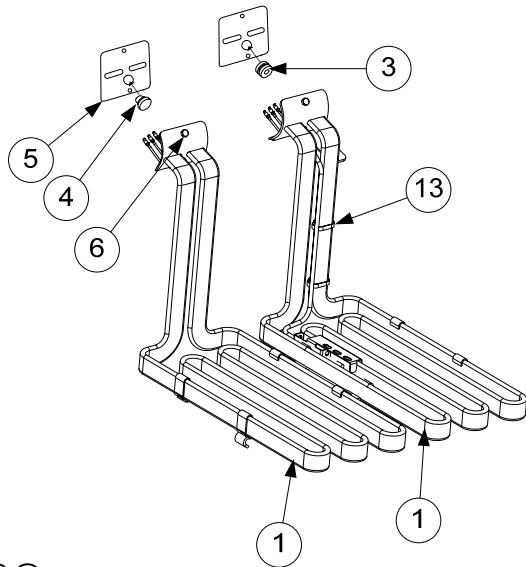

DUAL-VAT ELEMENT ASSEMBLY

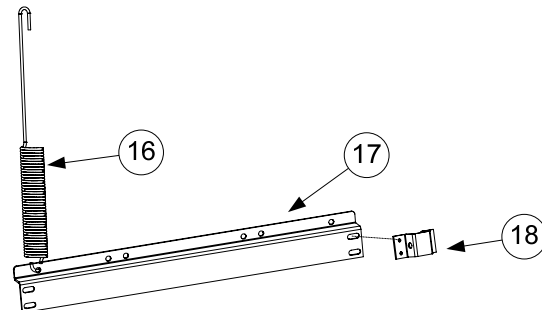
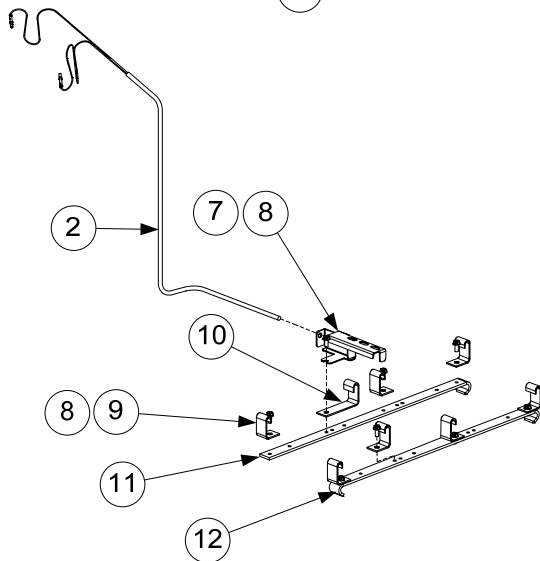
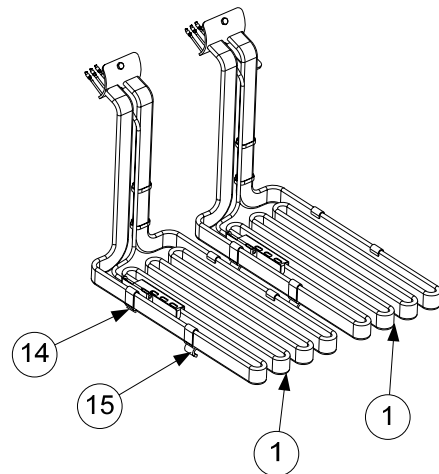

NOTES:

The dual-vat assembly is almost the same as the full-vat assembly except for having two of Items 2, 3, 7, 14 and 15. The only difference between element assemblies for different voltage and kW ratings is the element itself (Item 1).

Items 16, 17 and 18 are shown as associated parts. They are not part of either assembly.

NOTE: These elements apply only to RE series fryers. For the previous model elements see manual PN 819-6011.

2.4.4.1 Element Assemblies and Hardware cont.

ITEM	PART #	COMPONENT
1		Element
	826-2198	200V 7.0 kW
	826-2192	208V 7.0 kW
	826-2200	220V 7.0 kW
	826-2193	230V 7.0 kW
	826-2199	230V/400V 7.0/8.5 kW (used in some export 3-phase 4-wire WYE units)
	826-2194	240V 7.0 kW
	826-2196	480V 7.0 kW
2	826-2212	Probe, Temperature RE – includes tie wraps and grommet.
3	816-0681	Grommet, Probe
4	816-0480	Plug, .375-inch Dome
5	816-0688	Gasket, Element
6	809-1003	Screw, 10-32 X 3/8-inch Hex Head SS
*	809-0766	Nut, 10-32 Keps Hex Head SS
7	230-3714	Bracket, Temperature Probe 7.0kW
	230-0784	Bracket, Temperature Probe 8.5kW (used in some export 3-phase 4-wire WYE units)
8	809-0518	Screw, 8-32 X 3/8-inch Slotted Hex Head
9	910-2042	Clamp, Element (Short)
10	230-0781	Clamp, Element (Long)
11	230-4902	Support, Full-Vat Element Rear
12	230-4101	Support, Full-Vat Element Front
13	809-0567	Tie-Wrap, Metal
14	230-4903	Support, Dual-Vat Element Rear
15	230-4103	Support, Dual-Vat Element Front Dual Vat 14kW
16	810-3030	Spring, Element Lift Left
	810-3131	Spring, Element Lift Right
17	220-1190	Bracket, Lower Spring Single Foot Print
	220-0464	Bracket, Lower Spring
18	220-0733	Bracket, Lower Spring Mating

* Not illustrated.

2.4.4.2 Element Tube Assemblies

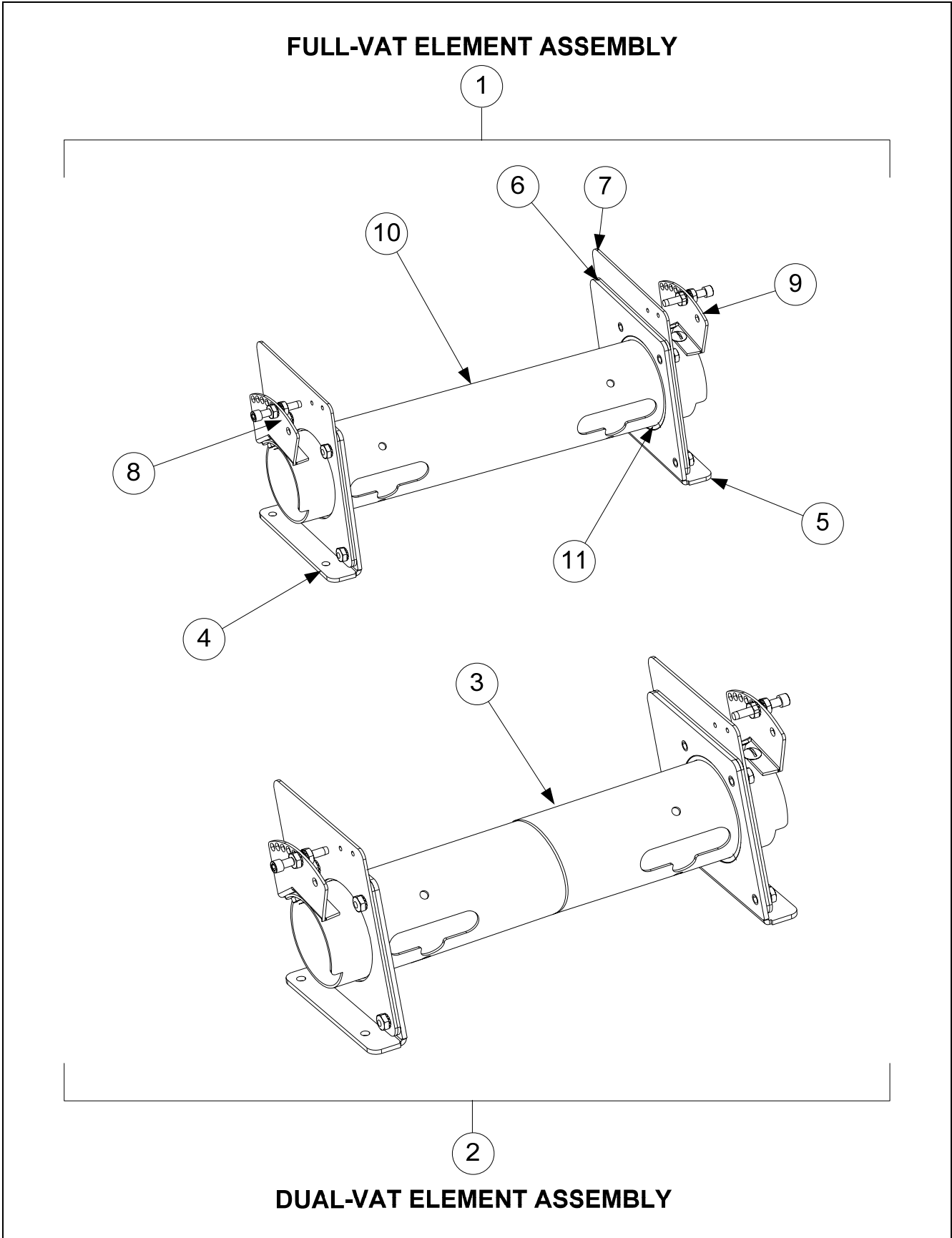

2.4.4.2 Element Tube Assemblies contd.

ITEM	PART #	COMPONENT
1	106-7653SP	Tube Assembly RE Element, Full-Vat
2	106-7654SP	Tube Assembly RE Element, Dual-Vat
3	810-3246	Bushing and Tube Assembly, Dual-Vat
4	106-5329	Bracket Assembly, LH Element Tube Support
5	106-5330	Bracket Assembly, RH Element Tube Support
6	220-0122	Plate, Element Tube Support Inner
7	220-0123	Plate, Element Tube Support Outer
8	106-7651	Bracket Assembly, LH Upper Spring (<i>use 106-6569 for 17kW</i>)
9	106-7652	Bracket Assembly, RH Upper Spring (<i>use 106-6570 for 17kW</i>)
10	810-2992	Tube, FV Element Mounting
11	810-2993	Bushing, Tube End Teflon
*	106-6587	Magnetic Position Sensor Assembly
*	826-2228	Magnetic Position Sensor Assembly with Bracket
*	810-3007	Magnet
*	230-0794	Bracket, Magnetic Position Sensor Wire

* Not illustrated.

2.4.5 Computers

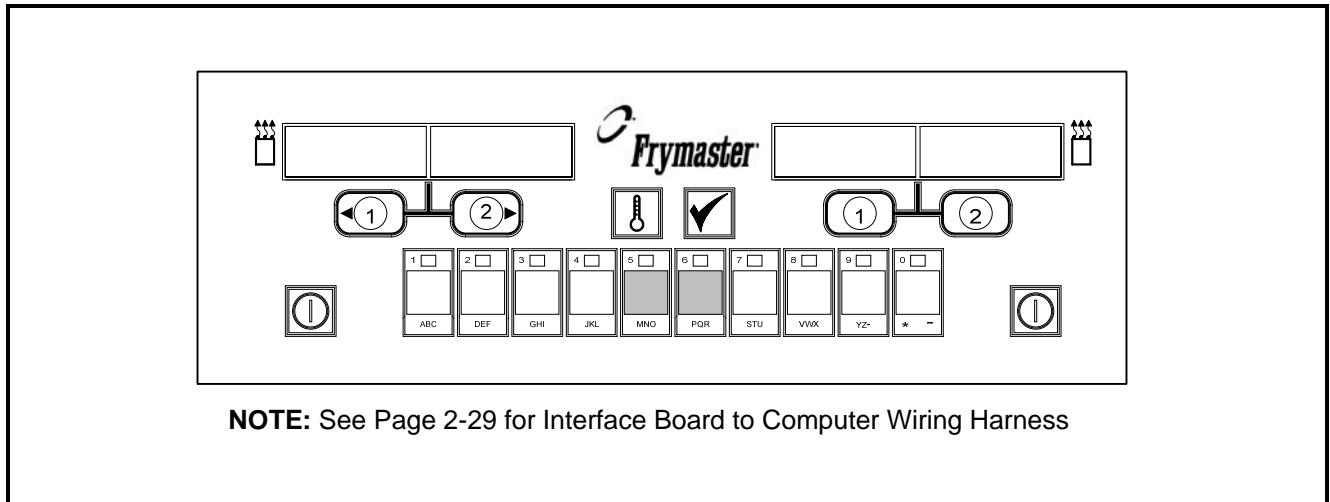

ITEM	PART #	COMPONENT
		Replacement Computer
	106-1269	Non-CE Domestic M2000
	106-0672	CE M2000

2.4.6 Wiring

2.4.6.1 Contactor Box Wiring Assemblies – 12-Pin Dual-Vat C-1

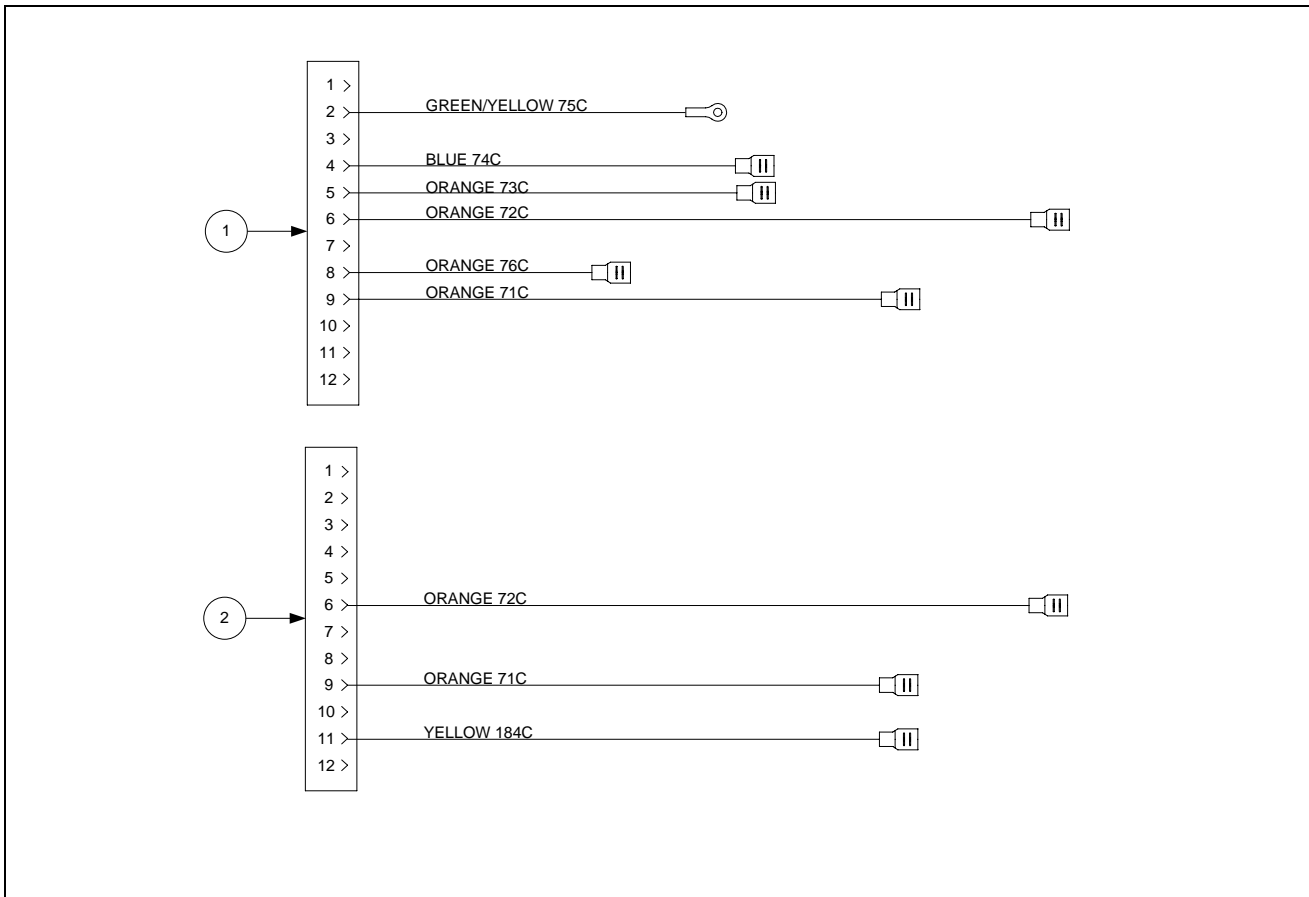

ITEM	PART #	COMPONENT
	106-5980	Contactor Box Harness Assembly Dual Vat
1		Standard
2		EPRI

2.4.6.2 Contactor Box Wiring Assemblies – 12-Pin Full-Vat C-1

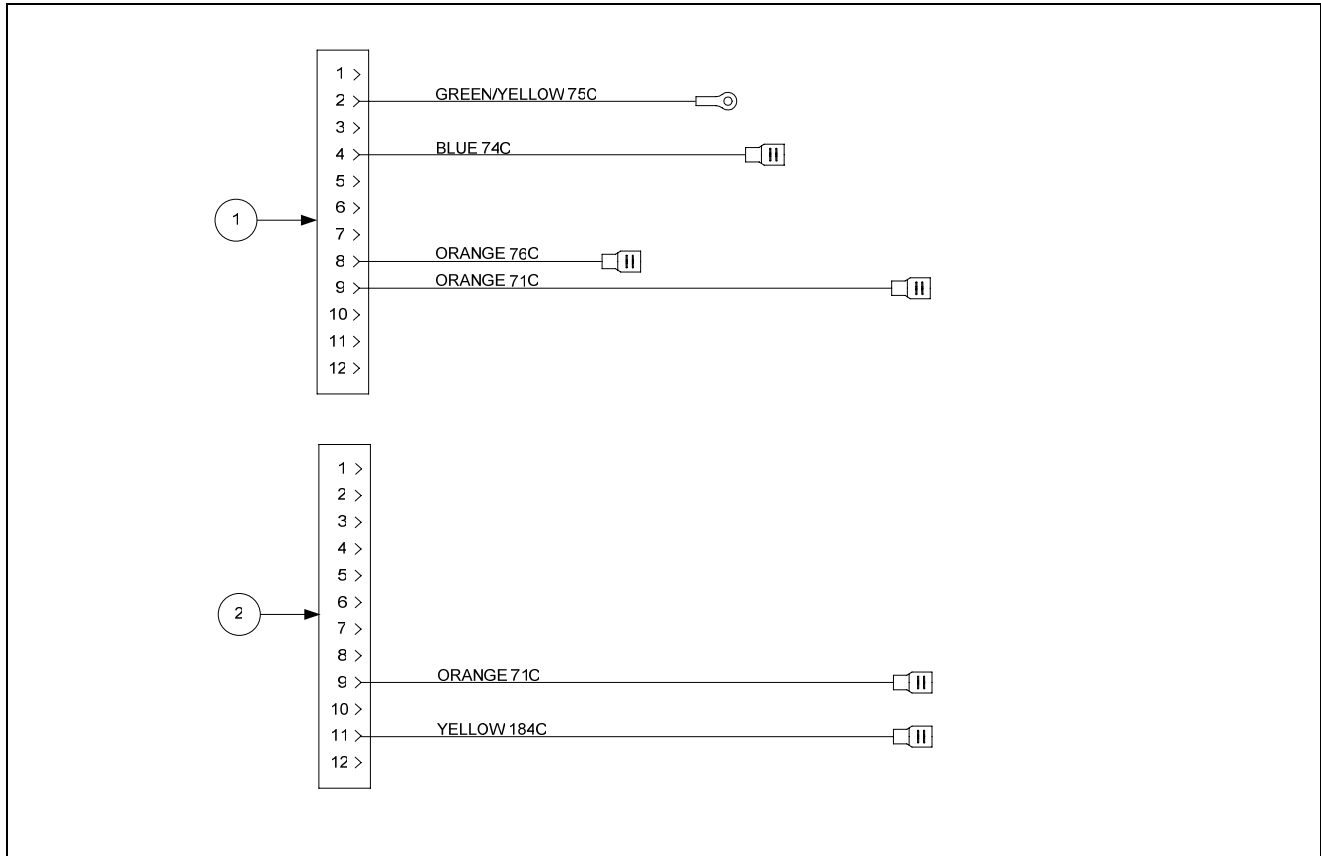

ITEM	PART #	COMPONENT
	106-6031	Contactor Box Harness Assembly Full Vat
1		Standard
2		EPRI

2.4.6.3 Contactor Box Wiring Assembly – 6-Pin (Left Element)

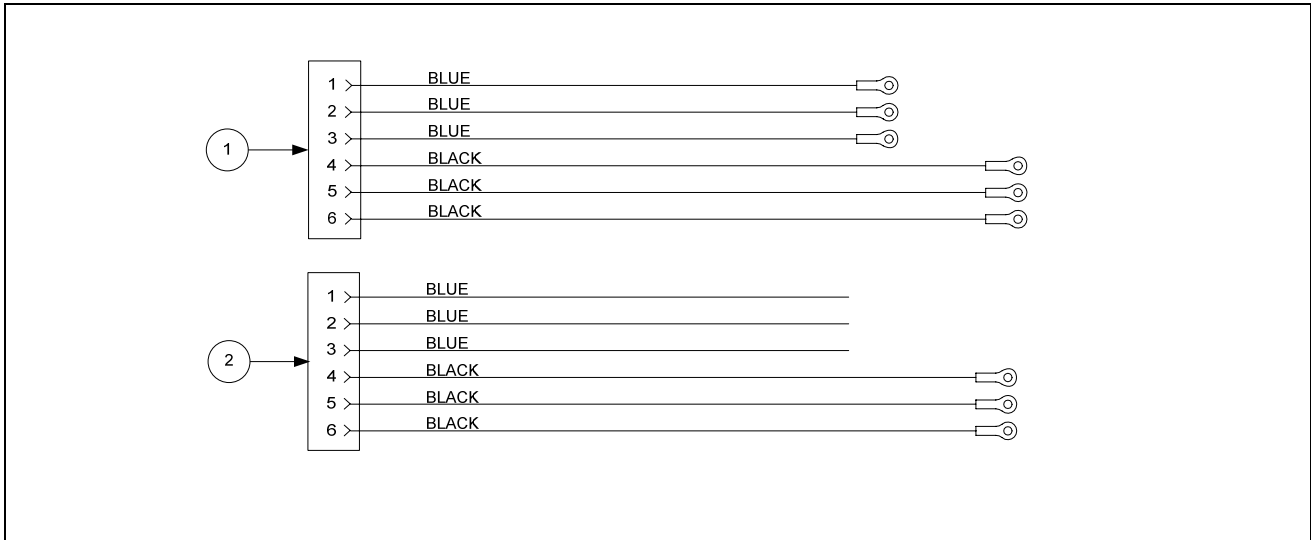

ITEM	PART #	COMPONENT
1	106-6768	14/17 kW Mercury Contactor
2	106-6771	14/17 kW Mechanical Contactor

2.4.6.4 Contactor Box Wiring Assembly – 9-Pin (Right Element)

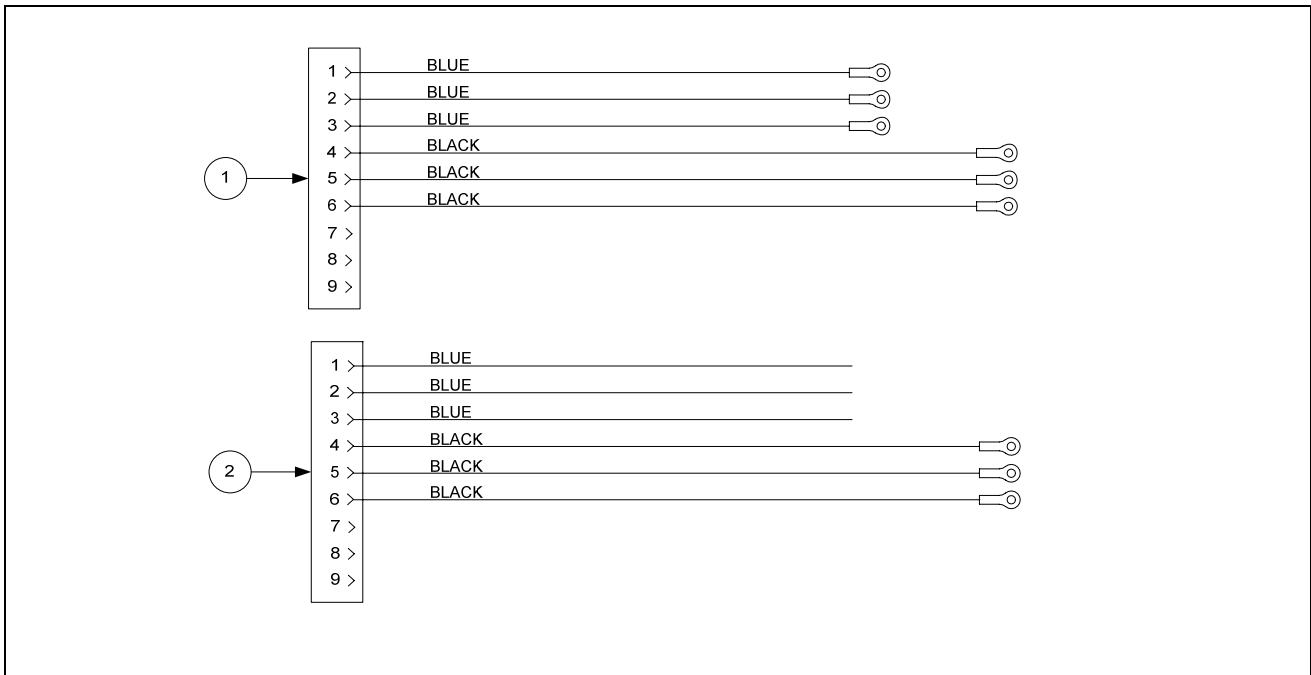

ITEM	PART #	COMPONENT
1	106-6769	14/17 kW Mercury Contactor
2	106-6772	14/17 kW Mechanical Contactor

2.4.6.5 Main Wiring Harnesses

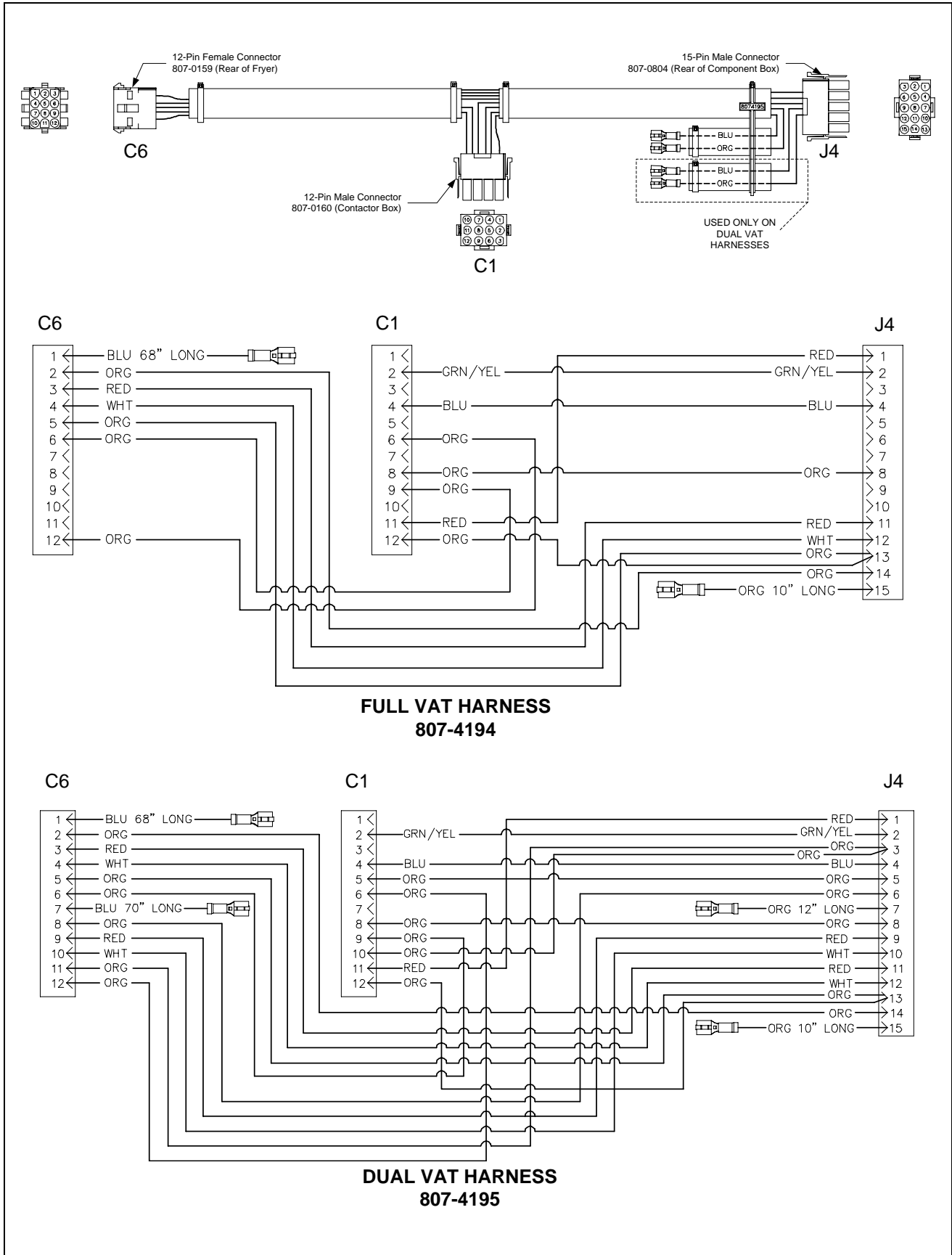

2.4.6.6 Component Box and Filter Pump Wiring Harnesses

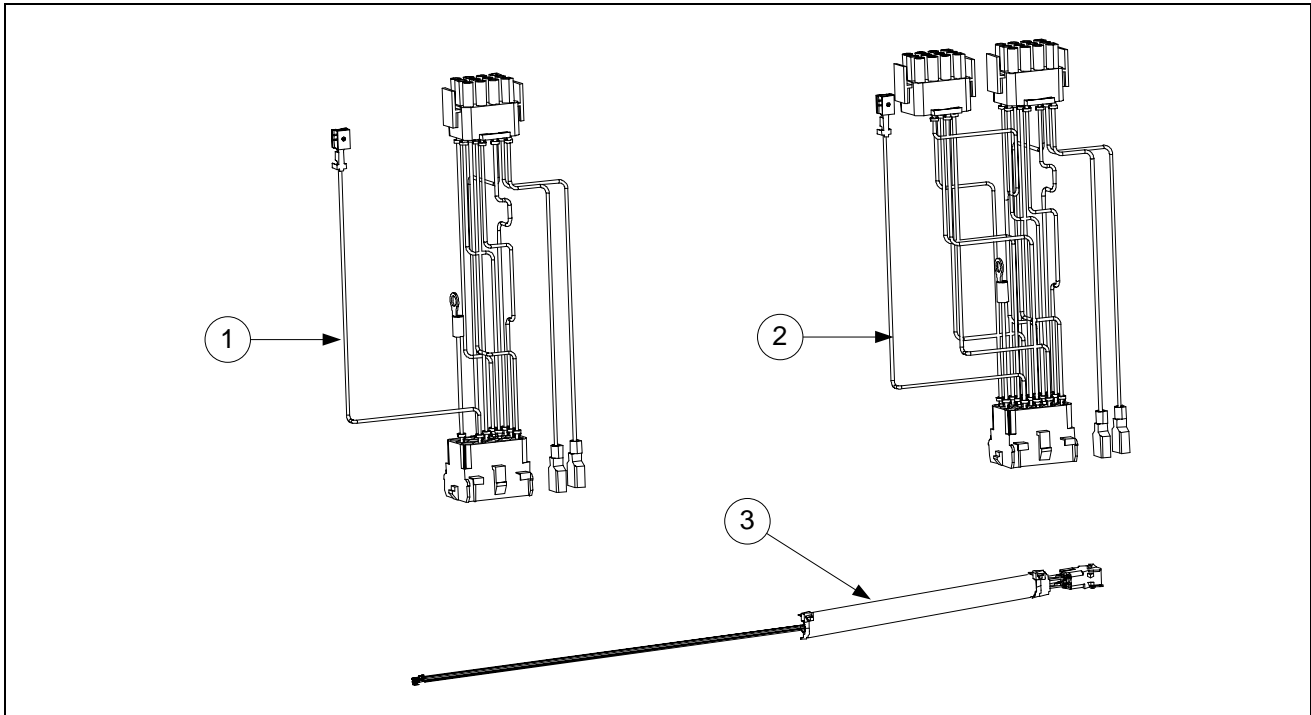

ITEM	PART #	COMPONENT
1	106-5750	Full Vat Control Harness J4 to J2 (<i>Standard</i>)
	106-6639	Full Vat Control Harness J4 to J2 (<i>EPRI</i>)
2	106-5751	Dual Vat Control Harness J4 to J1 and J2 (<i>Standard</i>)
	106-6644	Dual Vat Control Harness J4 to J1 and J2 (<i>EPRI</i>)
3	106-5935	Filter Pump C2 to Component Box Wiring Harness

2.4.6.7 Component Box to Filter Pump Harness

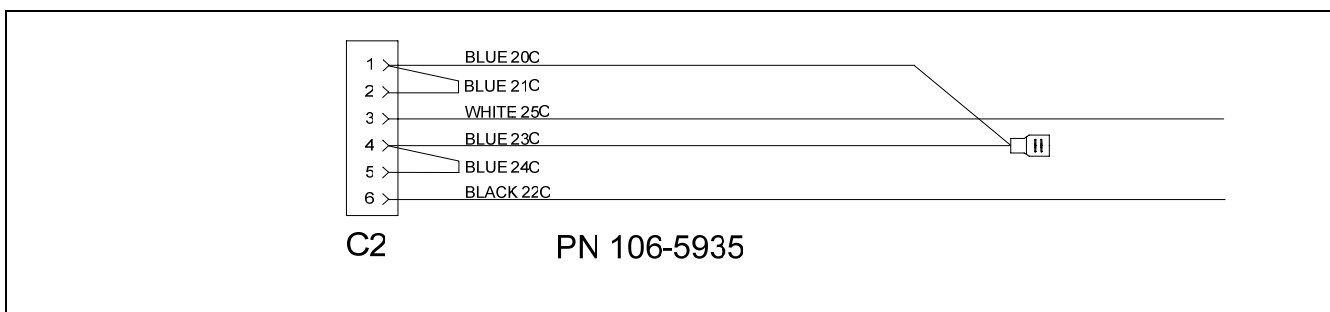

2.4.6.8 Interface Board to Controller Wiring Harness – 15-Pin

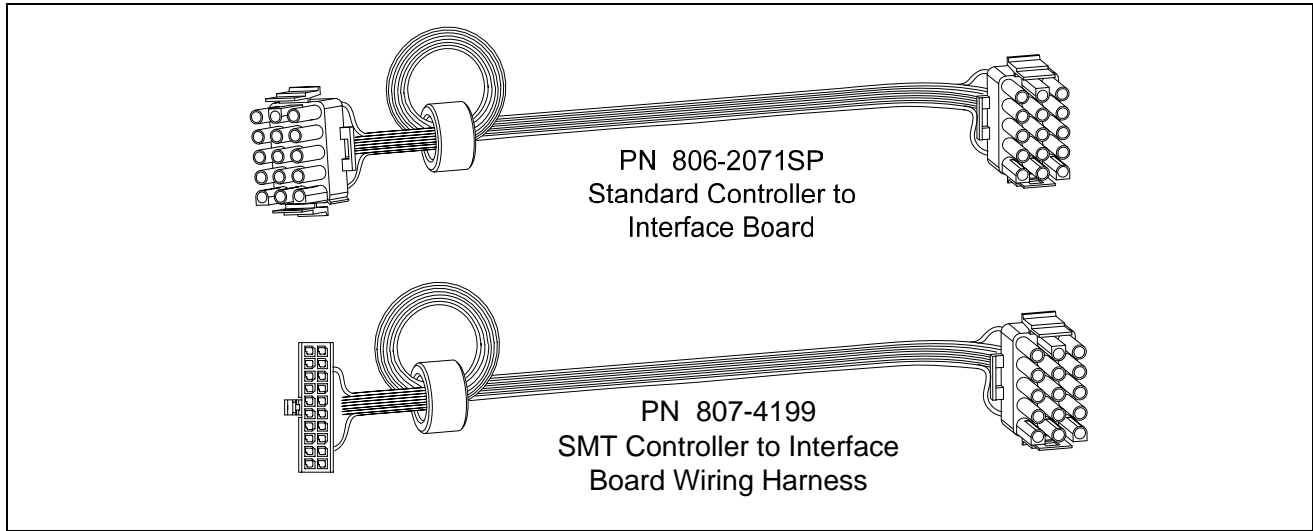

2.5 Filtration System Components

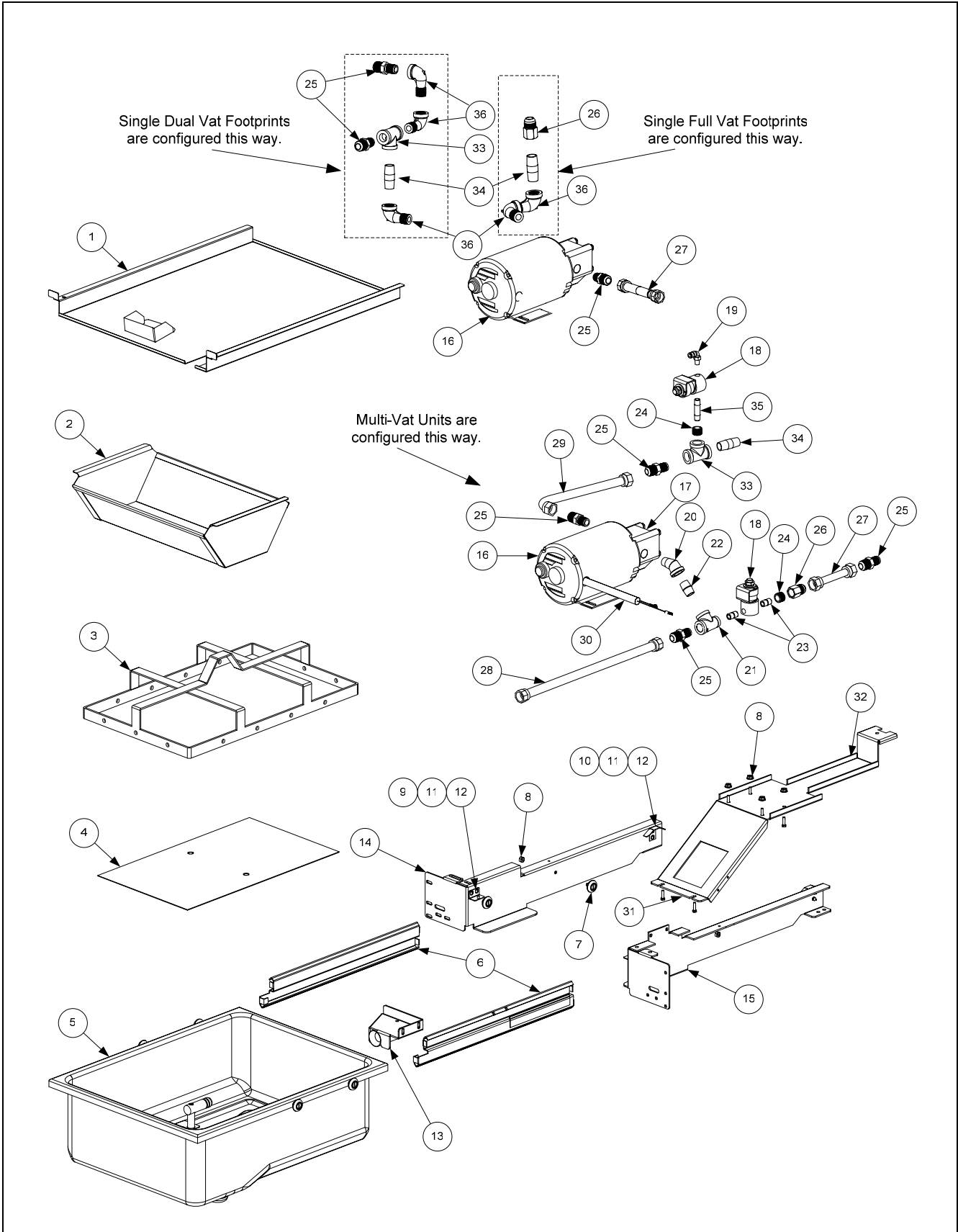

2.5 Filtration System Components cont.

ITEM	PART #	COMPONENT
*	826-1979	Filter Pan Roller Kit (four each of Items 7 and 8)
*	826-1980	Service Filter Pan (Item 5, four of Items 7 & 8, two O-rings and two of 813-0568)
*	826-1981	Service Filter Pan Assembly (Service Filter Pan plus Items 3 and 4)
*	826-1392	O-Ring (Pkg. of 5; used with Item 5)
*	813-0568	Plug, 1/8-inch Socket Head Pipe (used with Item 5; two required)
*	106-5911	Heater Strip Assembly, 100-120V 25W 18"
*	106-5912	Heater Strip Assembly, 208-250V 25W 18"
1	823-4637	Lid, Multi-Vat Fryers
	106-6243	Lid, Single Station Fryer Only Full Vat
	106-6310	Lid, Single Station Fryer Only Dual Vat
2	810-2874	Crumb Tray
	824-1707	Crumb Tray, Single Station Fryer Only
3	810-2909	Hold-Down Ring for Pad 11.20 x 19.10
	810-2910	Hold-Down Ring for Paper 13.65 x 21.41
	823-5774	Hold-Down Ring for Paper 8.98 x 19.39 Single Station Fryer Only
4	812-2025	SanaGrid Filter Screen
	220-1316	SanaGrid Filter Screen, Single Station Fryer Only
5	106-2617SP	Pan, One-Piece Filter (includes Item 2,)
	823-5594	Pan, One-Piece Filter Single Station Fryer Only
6	810-2012	Rail Set, Filter Pan Roller (includes one left and one right)
	826-1979	Kit, Roller (<i>includes 4 rollers, 4 nuts and 4 lock washers</i>)
7	810-2198	Roller, Filter Pan and Rail
8	826-1372	Nut, 1/4-20 Hex Flange (Pkg. of 10) (<i>use 809-0191 for lock washers</i>)
9	823-4589	Bracket, Lid Support
10		Guide, Filter Pan Lid
	200-3556	Left
	200-6709	Right
11	826-1363	Screw, 8-32 X 1/2-inch Slotted Truss Head (Pkg. of 25)
12	809-0247	Nut, 8-32 Hex Keps
13	823-3879	Suction Tube
14	200-4408	Rail, Left Filter
	106-5981	Support Assembly, Left Single Station Fryer Only
15	200-4409	Rail, Right Filter
	106-5982	Support Assembly, Right Single Station Fryer Only
16		Motor and Gasket Kit
	826-1785	100V 50/60 Hz
	826-1712	115V 50/60 Hz
	826-1756	208V 50/60 Hz
	826-1270	220-240V 50/60 Hz
	826-1755	250V 50/60 Hz
17	826-1264	Pump and Gasket Kit 4 GPM 2 piece
	816-0093	Gasket, Pump/Motor
*	807-11973	Viking Pump Seal Kit

* Not illustrated.

Continued on next page...

2.5 Filtration System Components cont.

ITEM	PART #	COMPONENT
18	807-2484	Valve, ¼-inch Solenoid
19	810-2493	Fitting, ¼-inch x 90° Quick-Connect
*	811-1071	Tubing, ¼-inch OD Teflon Vent (sold by the foot)
20	813-0342	Elbow, ½-inch 45° Street
21	813-0530	Tee, ½-inch X ¼-inch X ½-inch Reducing
22	813-0022	Nipple, ½-inch Close
23	813-0838	Nipple, ¼-inch Close
24	813-0304	Bushing, ½-inch to ¼-inch Flush
25	810-1668	Adapter, ⅝-inch to ½-inch NPT Male
26	810-1669	Adapter, ⅝-inch to ½-inch NPT Female
27	810-1680	Flexline, 6.5-inch Oil Return
28	810-1057	Flexline, 13-inch Oil Return
29	810-1043	Flexline, 9.5-inch Oil Return
30		Wiring Harness, Filter Pump
	106-5910	115/120V Filter Harness
	106-5906	208/230/240/250V Filter Harness
31	826-1375	Screw, 10-32 X ¾-inch Hex Trim Head (Pkg. of 5)
32	200-5950	Bridge, Filter Motor
	824-1705	Bridge Filter Single Station Fryer Only
33	813-0003	Tee, ½-Inch
34	813-0298	Nipple, ½-inch 2.0-inch
35	813-0537	Nipple, ¼-inch 2.0-inch
36	813-0165	Elbow, ST ½-inch x ½-inch NPT 90° BM

2.6 Frypot Assemblies and Associated Parts

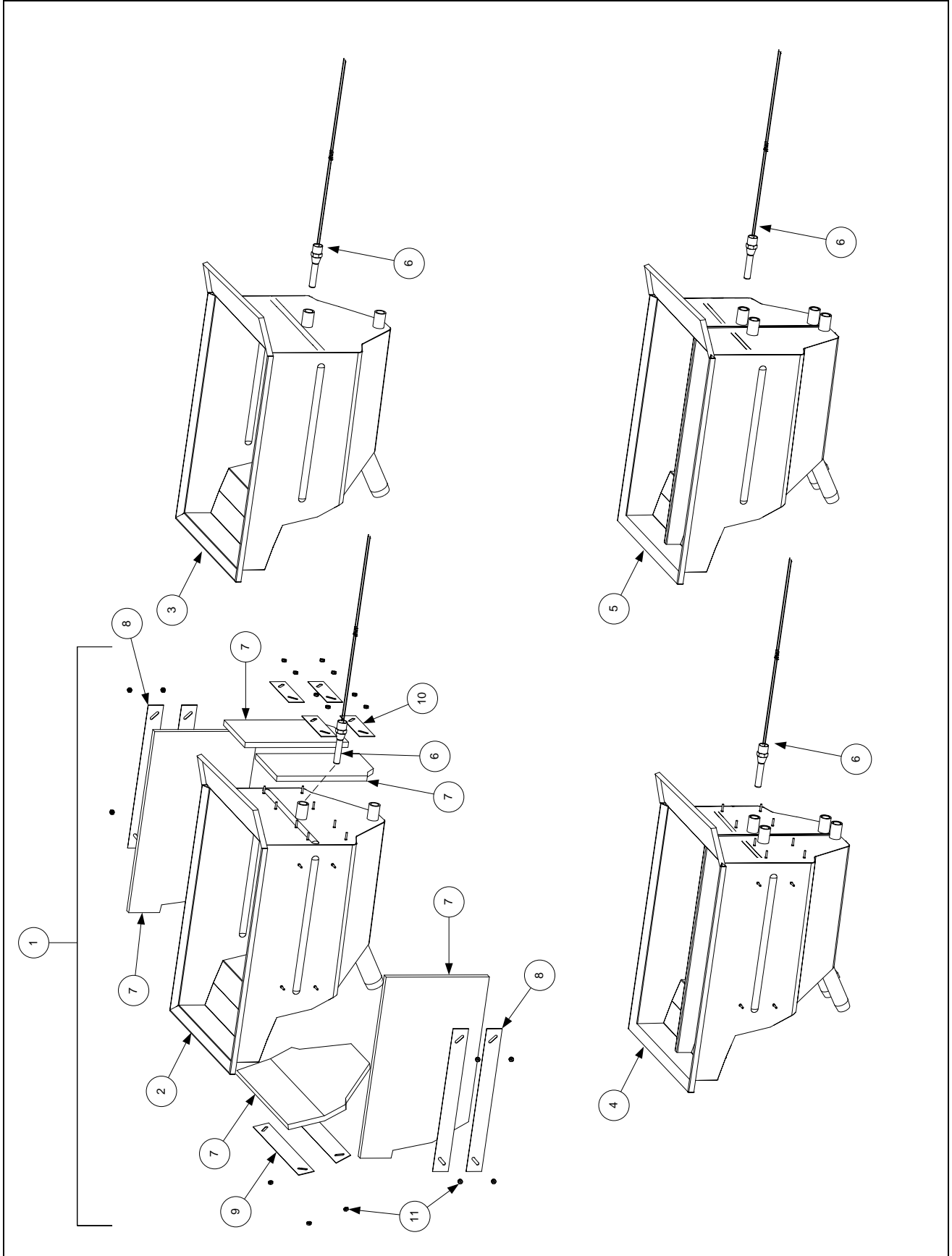

2.6 Frypot Assemblies and Associated Parts cont.

ITEM	PART #	COMPONENT
1		Frypot Assembly (<i>does not include Item 6</i>)
2	823-5545SP	Frypot, Full-Vat Filter with Insulation (<i>for use on EPRI units</i>)
3	823-5359SP	Frypot, Full-Vat Filter w/o Insulation (<i>for use on Standard units</i>)
4	823-5551SP	Frypot, Dual-Vat Non-Filter with Insulation (<i>for use on EPRI units</i>)
5	823-5482SP	Frypot, Dual-Vat Filter w/o Insulation (<i>for use on Standard units</i>)
6		Thermostat Assembly, High-Limit
	826-2454	Non-CE Full Vat 425°F (218°C) (17kW FV and 14kW FV) (Color Coded Black 806-7543)
	826-2456	Non-CE Dual Vat 435°F (224°C) (22kW, 17kW DV and 14 kW DV) (Color Coded Red 806-8035)
	826-2455	CE Full and Dual Vat 415°F (213°C) (14kW and 17kW CE) (Color-Coded Yellow 806-8132)
7	812-0211	Insulation, Kaowool 17-inch X 10-inch X ½-inch (4 required per pot)
8	900-4100	Retainer, Side Insulation
9	900-4101	Retainer, Front Insulation
10	900-1345	Retainer, Rear Insulation
11	826-1376	Nut, 10-32 Keps Hex (Pkg. of 10)

NOTES: The frypots for EPRI-equipped units are insulated; those for non-EPRI (standard) units are not. EPRI frypot assemblies 806-5545SP and 806-5551SP consist of the Items 2 and 4 respectively, plus insulation (Items 7-10). When replacing insulation or adding insulation to a bare frypot, the individual pieces (sides, front, and back) are cut to fit from Item 7 when installed. Each frypot requires four uncut pieces of insulation.

2.7 Oil Return System Components

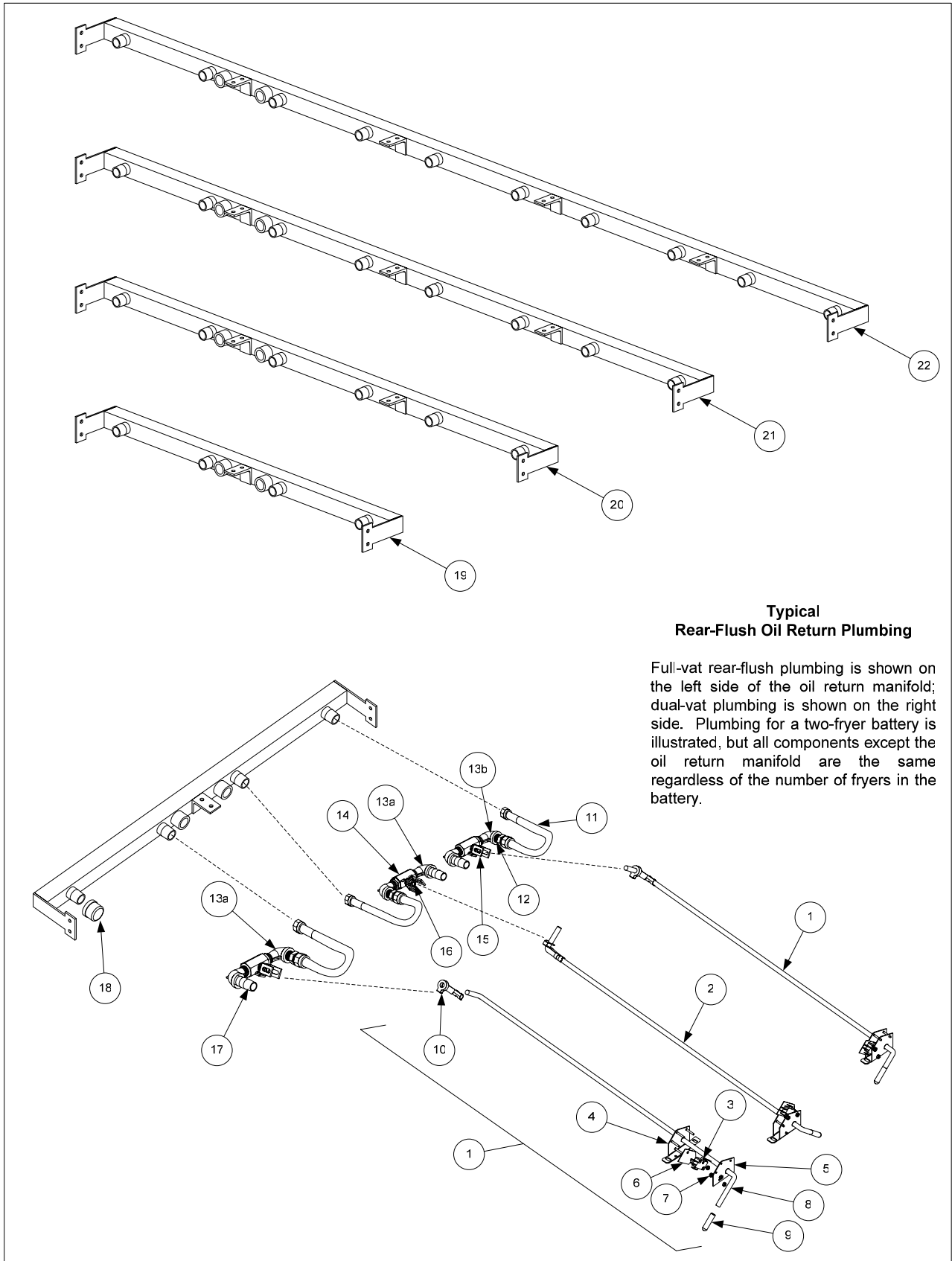

Typical Rear-Flush Oil Return Plumbing

Full-vat rear-flush plumbing is shown on the left side of the oil return manifold; dual-vat plumbing is shown on the right side. Plumbing for a two-fryer battery is illustrated, but all components except the oil return manifold are the same regardless of the number of fryers in the battery.

2.7 Oil Return System Components cont.

ITEM	PART #	COMPONENT
1	106-2465SP	Handle Assembly, Full-Vat and Right Dual-Vat Rear Flush Complete
2	106-2687SP	Handle Assembly, Left Dual-Vat Rear Flush Complete
3	807-2103	Microswitch, Straight Lever
4	106-3349	Bracket Assembly, Microswitch
5	200-5401	Bracket, Handle Retainer
6	816-0220	Insulation, Oil Return Microswitch
7	826-1366	Nut, 4-40 Keps Hex (Pkg. of 25)
8	810-2534	Rod, Full-Vat and Right Dual Vat Rear Flush
	810-2533	Rod, Left Dual Vat Rear Flush
9	816-0643	Grip, Oil Return Valve Handle
10	809-0601	Clip, Clevis
11	810-2532	Flexline, 7.0-inch
	810-1057	Flexline, 13.0-inch Single Footprint Only Full Vat and Dual Vat Left Side
	810-1055	Flexline, 11.5-inch Single Footprint Only Dual Vat Right Side
12	810-1668	Adapter, 5/8-inch to 1/2-inch NPT Male
13a	813-0165	Elbow, 1/2-inch X 90° Street
13b	813-0908	Adapter, 1/2-inch NPT M/T 90° (<i>used only on side next to cabinet</i>)
14	810-0278	Valve, 1/2-inch Ball
15	200-5438	Handle, Rear Flush Valve
16	900-2935	Retainer, Oil Return Valve Nut
17	813-0460	Nipple, 1/2-inch X 3.0-inch NPT
18	813-0907	Cap, 15/16-inch Valve Safety
19	810-3015	Manifold, Two-Station Fryer (<i>use 810-2543 for non-filter units</i>)
20	810-3016	Manifold, Three-Station Fryer (<i>use 810-2544 for non-filter units</i>)
21	810-3017	Manifold, Four-Station Fryer (<i>use 810-2545 for non-filter units</i>)
22	810-3018	Manifold, Five-Station Fryer (<i>use 810-2546 for non-filter units</i>)

2.8 Wiring Connectors, Pin Terminals, and Power Cords

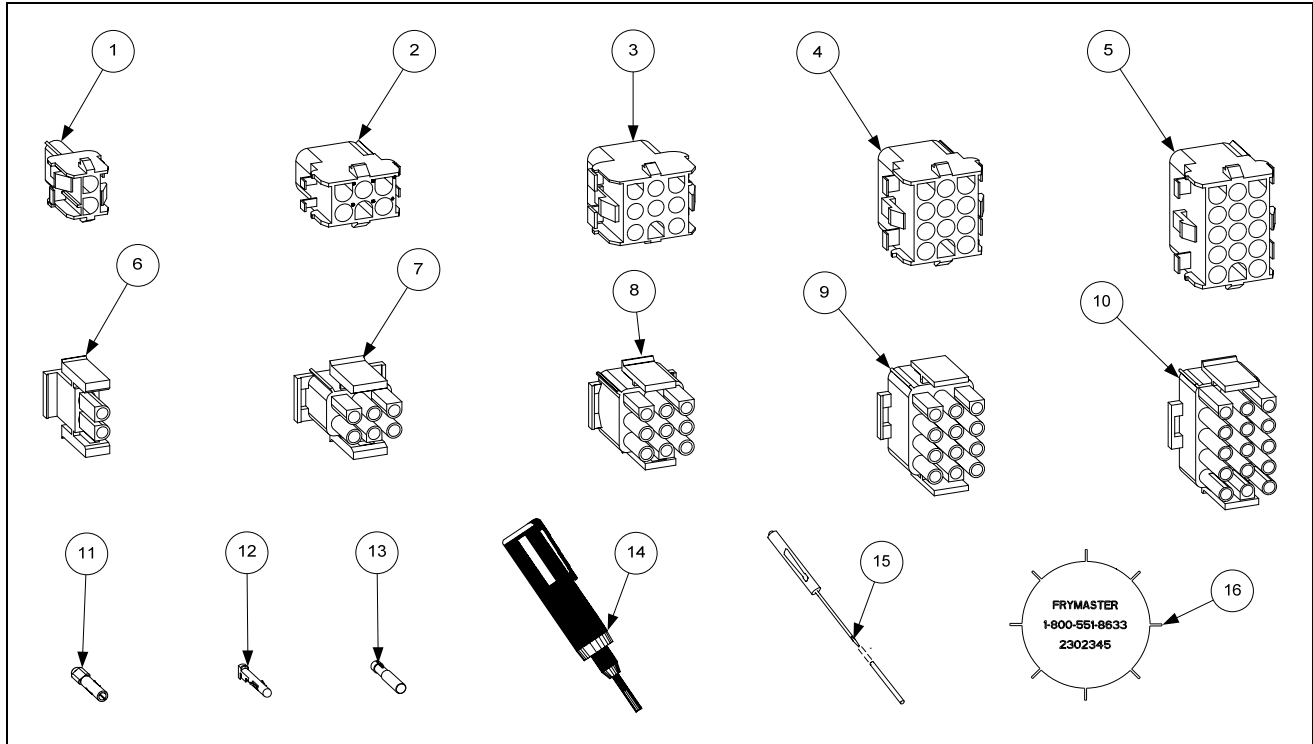

ITEM	PART #	COMPONENT
		Power Cords
*	807-0154	100/120V–15A 3-wire, w/grounded plug
*	807-4317	100/208/240V-16A 3-Wire with Plug BIRE/MRE CE
*	807-1685	100/208/240V–18A 3-wire, w/o plug
*	807-4316	120V 5-wire, w/grounded plug BIRE/MRE
*	807-3817	208/240V 3-Phase 4-wire w/grounded plug
		Connectors
1	807-1068	2-Pin Female
2	807-0158	6-Pin Female
3	807-0156	9-Pin Female
5	807-0159	12-Pin Female
5	807-0875	15-Pin Female
6	807-1067	2-Pin Male
7	807-0157	6-Pin Male
8	807-0155	9-Pin Male
9	807-0160	12-Pin Male
10	807-0804	15-Pin Male
11	826-1341	Terminal, Female Split Pin (Pkg of 25)
12	826-1342	Terminal, Male Split Pin (Pkg of 25)
13	807-2518	Plug, Mate-N-Lock (Dummy Pin)
14	807-0928	Extract Tool Pin Pusher
15	806-4855	Pin Pusher Screwdriver Assembly
16	230-2345	SMT Pin Extractor
*	807-4660PK	SMT Pin Service Repair Kit

* Not illustrated.

2.9 Fasteners

ITEM	PART #	COMPONENT
*	809-0429	Bolt, ¼-inch – 20 x 2.00-inch Hex Head ZP Tap
*	809-0514	Capscrew, 5/16-inch-18 NC Hex
*	809-0448	Clip, Tinnerman
*	826-1366	Nut, 4-40 Keps Hex (Pkg. of 25) (809-0237)
*	826-1358	Nut, 6-32 Keps Hex (Pkg. of 25) (809-0049)
*	809-0247	Nut, 8-32 Keps Hex
*	826-1376	Nut, 10-32 Keps Hex (Pkg. of 10) (809-0256)
*	809-0766	Nut, 10-32 Keps Hex SS
*	809-0581	Nut, ½ NPT Locking
*	809-0020	Nut Cap 10-24 NP
*	826-1372	Nut Grip ¼-inch 1/4-20 Hex NP (Pkg. of 10) (809-0059)
*	809-0417	Nut Flange ¼-inch 1/4-20 Serr
*	809-0535	Nut, "T" ¼-inch-20 x 7/16 SS
*	809-0540	Nut, Lock ½-inch-13 Hex 2-Way ZP
*	826-1359	Screw, 4-40 x ¾-inch Slotted Round Head (Pkg. of 25) (809-0354)
*	826-1365	Screw, 6-32 x ⅜-inch Slot Head (Pkg. of 25) (809-0095)
*	809-0357	Screw, 6 x ⅜-inch Phillips Head NP
*	809-0359	Screw, 8 x ¼-inch Hex Washer Head
*	809-0360	Screw, 8 x ⅜-inch Hex Washer Slot Head
*	826-1371	Screw, 8 x ½-inch Hex Head ZP (Pkg. of 25) (809-0361)
*	809-0364	Screw, 8 x ⅝-inch Hex Washer Head ZP
*	809-0518	Screw, 8-32 x ⅜-inch Hex Washer Slotted Head SS
*	809-0104	Screw, 8-32 x ½-inch Slotted Head ZP
*	826-1363	Screw, 8-32 x ½-inch NP (Pkg. of 25) (809-0103)
*	826-1360	Screw, 10-24 x 5/16-inch Round Slot Head ZP (Pkg. of 25) (809-0024)
*	826-1330	Screw, 10-32 x ⅜-inch Slot Head SS (809-0117)
*	809-1003	Screw, 10-32 x ⅜-inch Hex Trim Head SS
*	826-1375	Screw, 10-32 x ¾-inch Hex Trim Head SS (Pkg. of 5) (809-0401)
*	809-1000	Screw, 10-32 x 1¼-inch Hex Sck C/S
*	826-1374	Screw, 10 x ½-inch Hex Head (Pkg. of 25) (809-0412)
*	809-0266	Screw, 10 x ½-inch Phillips Head ZP
*	809-0434	Screw, 10 x ⅜-inch Hex Washer Head NP
*	809-0123	Screw, 10 x ¾-inch Slot Head
*	826-1389	Screw, 1/4-20 x ¾-inch Hex Head ZP (Pkg. of 10) (809-0131)
*	809-0582	Washer ½ NPT Locking
*	809-0184	Washer, #10 LK ZP
*	809-0190	Washer, .625 X .275 X 40 Flat SS
*	809-0191	Washer, Lock 1/4 Spring ZP
*	809-0193	Washer, Flat 1/4 Nylon
*	809-0194	Washer, Flat 5/16 ZP

THIS PAGE INTENTIONALLY LEFT BLANK



Frymaster, L.L.C., 8700 Line Avenue, PO Box 51000, Shreveport, Louisiana 71135-1000
Shipping Address: 8700 Line Avenue, Shreveport, Louisiana 71106

TEL 1-318-865-1711

FAX (Parts) 1-318-219-7140

(Tech Support) 1-318-219-7135

PRINTED IN THE UNITED STATES

SERVICE HOTLINE
1-800-551-8633

819-6152
AUG 2009