

# Food Warmer Parts Manual

FWH-1, FWH-2, Hatco, ThermoGlo

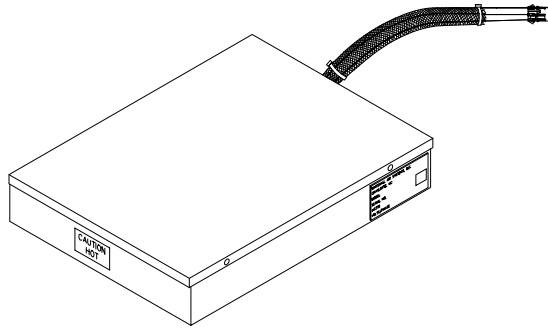
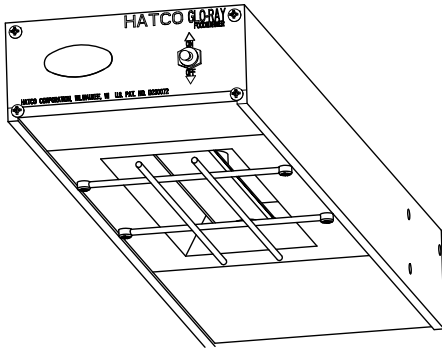
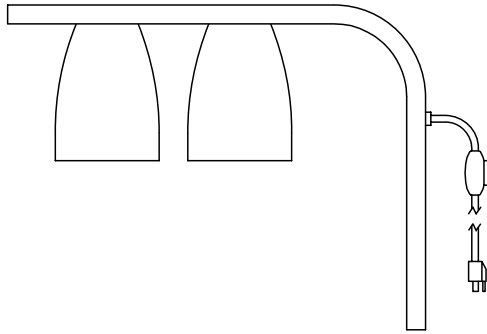
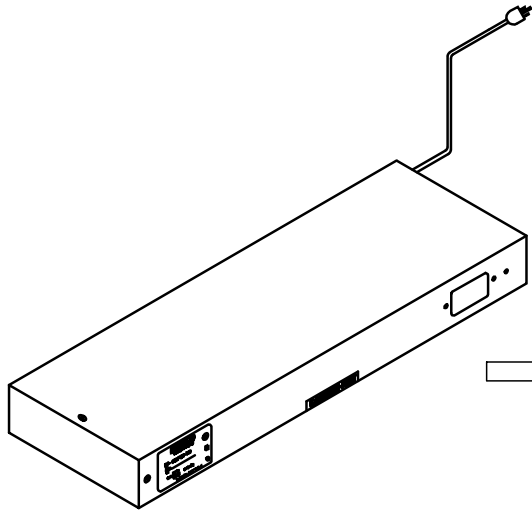

Frymaster, a member of the Commercial Food Equipment Service Association, recommends using CFESA Certified Technicians.

\* 8196330 \*

**24-Hour Service  
Hotline 1-800-551-  
8633**

AUG 09

**NOTICE**

IF, DURING THE WARRANTY PERIOD, THE CUSTOMER USES A PART FOR THIS ENODIS EQUIPMENT OTHER THAN AN **UNMODIFIED** NEW OR RECYCLED PART PURCHASED DIRECTLY FROM FRYMASTER/DEAN, OR ANY OF ITS AUTHORIZED SERVICE CENTERS, AND/OR THE PART BEING USED IS MODIFIED FROM ITS ORIGINAL CONFIGURATION, THIS WARRANTY WILL BE VOID. FURTHER, FRYMASTER/DEAN AND ITS AFFILIATES WILL NOT BE LIABLE FOR ANY CLAIMS, DAMAGES OR EXPENSES INCURRED BY THE CUSTOMER WHICH ARISE DIRECTLY OR INDIRECTLY, IN WHOLE OR IN PART, DUE TO THE INSTALLATION OF ANY MODIFIED PART AND/OR PART RECEIVED FROM AN UNAUTHORIZED SERVICE CENTER.

** DANGER**

Copper wire suitable for at least 167°F (75°C) must be used for power connections.

** DANGER**

The electrical power supply for this appliance must be the same as indicated on the rating and serial number plate located on the inside of the fryer door.

** DANGER**

This appliance must be connected to the voltage and phase as specified on the rating and serial number plate located on the inside of the fryer door.

** DANGER**

All wiring connections for this appliance must be made in accordance with the wiring diagrams furnished with the equipment. Wiring diagrams are located on the inside of the fryer door.

** DANGER**

Do not store or use gasoline or other flammable vapors and liquids in the vicinity of this or any other appliance.

** WARNING**

Do not use water jets to clean this equipment.

# Table of Contents

Equipment	Page Number
FWH-1, Merco Rod-Style	1
FWH-2, Bulb Style	2
Hatco	3
ThermoGlo	4
Inserts, Pans: 35/45/55 Gas, RE Electric, Protector	5
Inserts, Pans: MJCF, Filter Magic	6
55 Cabinet	7
35/45 Cabinet	8
RE Cabinet	9
Casters/Legs/Anchors	10

# Heat Lamps/Food Warmers

## FWH-1, Merco Rod-Style

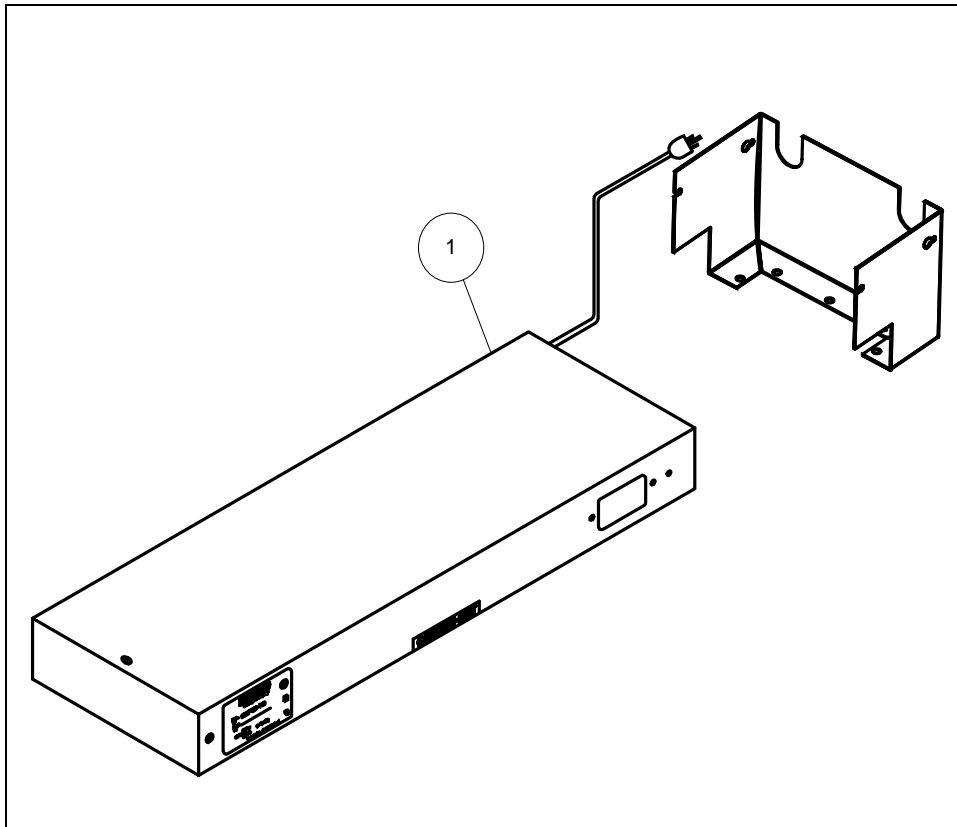

1	807-4356	Food warmer, 120/60 825W
*	807-4402	Food warmer, 240V
*	807-1413	120V Switch, toggle, ON/OFF
*	807-1414	240V Switch, toggle, ON/OFF
*	807-1416	Power on indicator light, red
*	807-1417	120V cordset, 3 wire
*	807-4358	120V Element (tube) heating, 20 1/4", 825W (screw-in)
*	807-4359	208/240 Element (tube) heating, 20 1/4" 825W (screw-in)
*	807-0746	120V Element (tube) heating, 20 1/4", 825W (snap-in)
*	807-0748	208/240 Element (tube) heating, 20 1/4" 825W (snap-in)
*	807-1415	Socket, heating rod (snap-in)
*	807-3783	Switch, Dean
*	826-0990	Hardware kit
*	810-2389	Holder, Quartz Lamp, (snap-in) Dean
*	210-5717	Bracket, Heat Lamp
*	210-5716	Mount, Heat Lamp

# Heat Lamps/Food Warmers

## FWH-2, Bulb Style

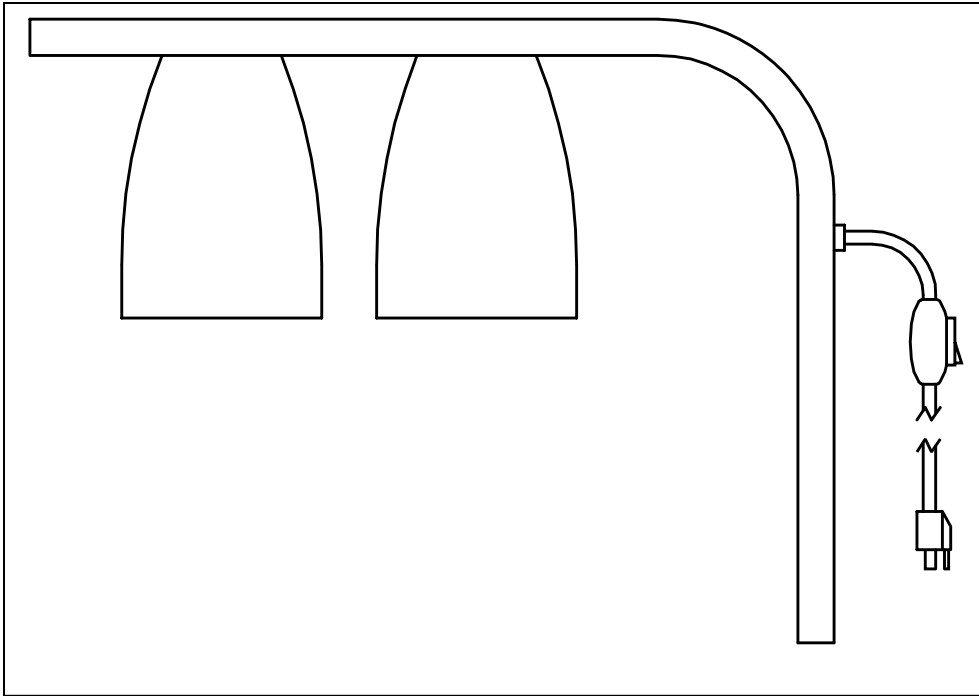

	807-1575	120V Warmer, with support
	807-1576	240V Warmer, with support
	806-5278SP	120V Warmer kit, with mounting hardware
	806-5285SP	240 Warmer Kit, with mounting hardware
	807-3963	Socket, heating, bulb, 375W
	807-3049	Bulb, 250W, 120V
	807-3961	Bulb, 375W, 120V
	807-3962	Bulb, 375W, 240V
	826-1064	Hardware kit, (screws for attachment)
	823-1896	Support, lamp, front/rear
	807-3051	Cordset, in-line switch
	826-1374	Screw, #10 (Qty:25)

# Heat Lamps/Food Warmers

## Hatco Warmers

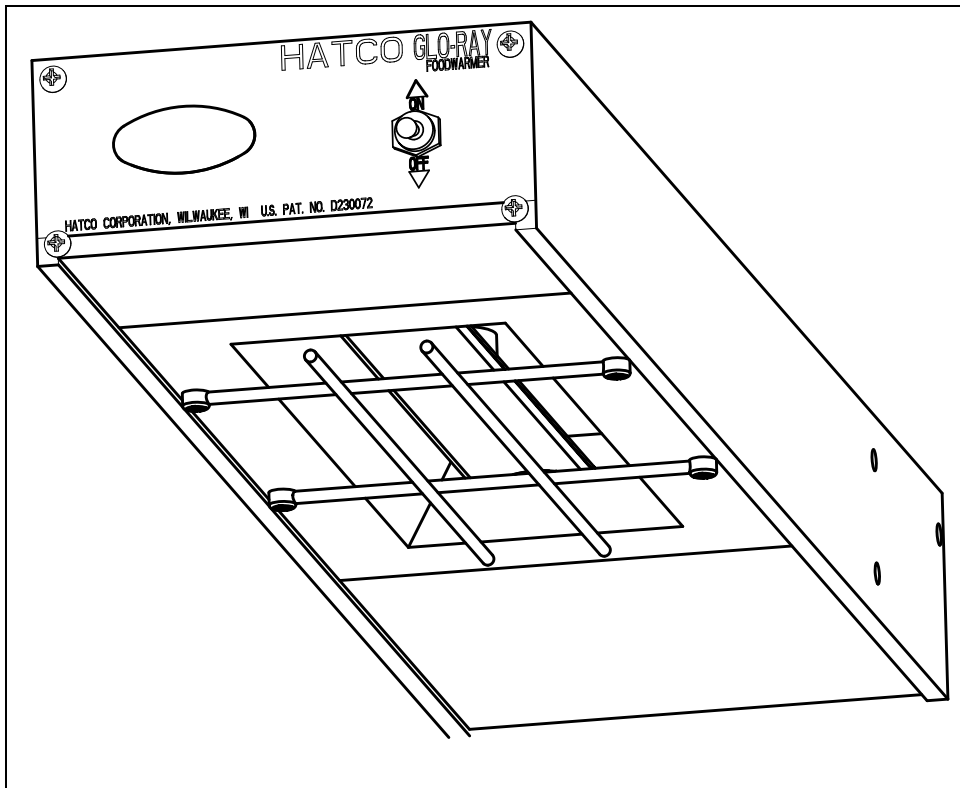

	807-3219	240V Warmer assembly
	807-4696	230/240 CE Warmer assembly
<b>Frymaster Replacement Parts</b>		
	910-8627	Housing support
	823-2834	Plate, mount with nut
	826-0990	Mounting kit, hardware
<b>Dean Replacement Parts</b>		
	823-3963	Support weld assembly

# Heat Lamps/Food Warmers

## ThermoGlo Warmers

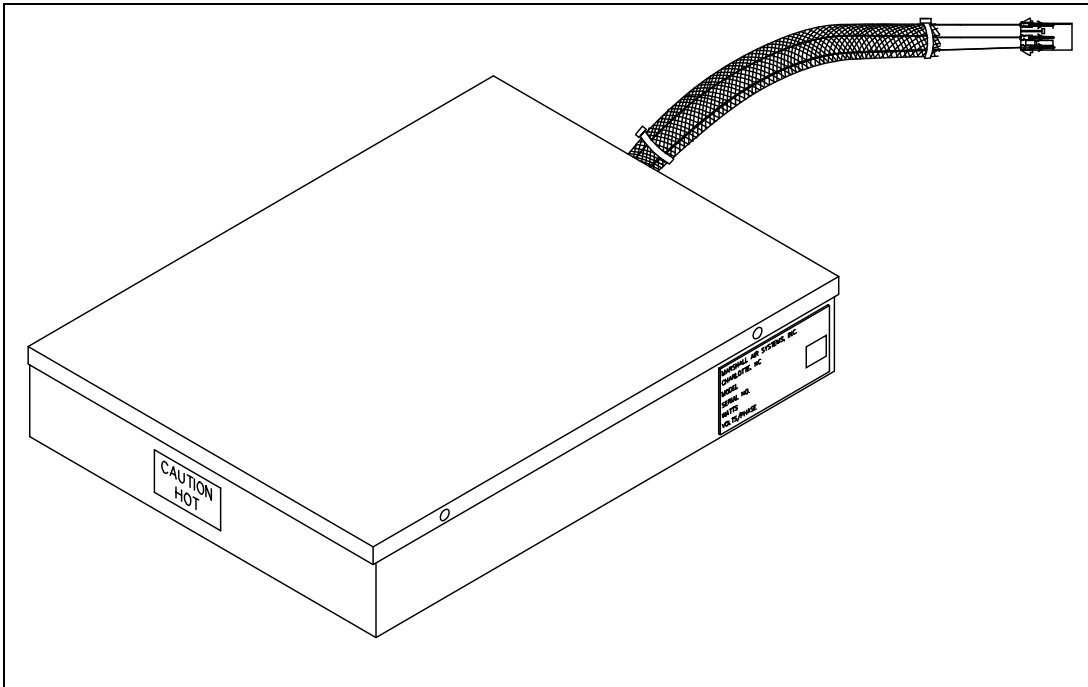

	806-8836SP	120V Warmer
	826-1279	120V Warmer kit
	807-3353	240V Warmer
	807-2082	Switch, rocker, power, ON/OFF
	807-1041	Switch, toggle, power, ON/OFF
	806-7732SP	Harness, wire

# Heat Lamps/Food Warmers

## Inserts/Pans 35/45/55 Gas Fryers and RE, Protector Electric Fryers

**NOTE:** Holding stations can be equipped with scoop or café pan holding areas. The inserts, which hold the pans in place, are different, depending on the style pan they hold. The inserts are also different for gas and electric fryers.

### Café Pan Inserts

Café pan inserts have rounded corners

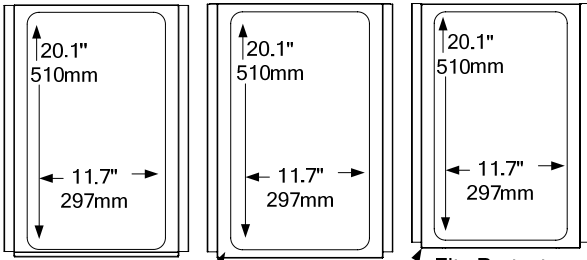

Fits 35/45/55 cabinets

Fits RE cabinets

Fits Protector Cabinets

230-6063

824-1662

824-1947

### Café Pan Grate

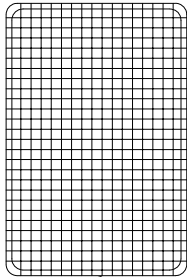

803-0104

Fits all café pan inserts

### Café Pan

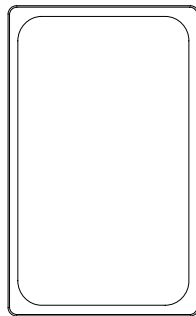

803-0054

Fits all café pan inserts

### Scoop Pan Inserts

Scoop pan inserts have square corners

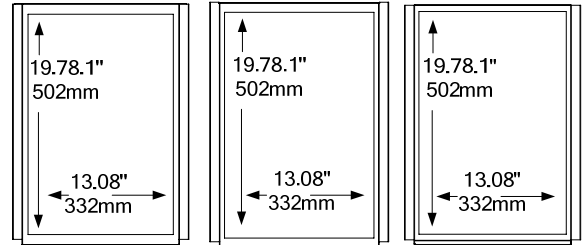

Fits 35/45/55 cabinets

Fits RE cabinets

Fits Protector cabinets

230-6064

824-1720

824-1948

### Scoop Inset Pan

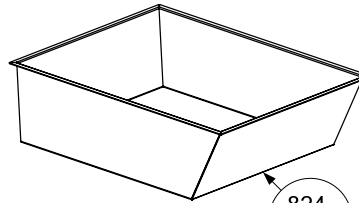

Fits all scoop inserts

824-1960

### Scoop

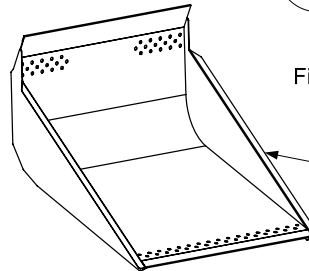

Fits all scoop inserts

823-1865

### Cover

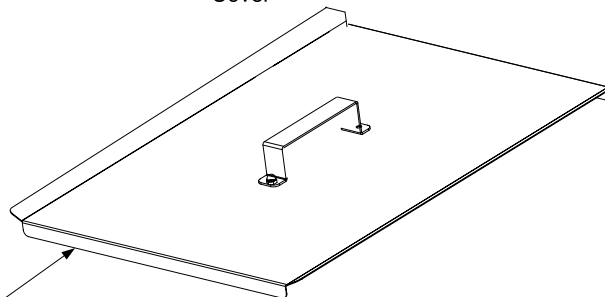

806-5518

Fits scoop or café pan



# Heat Lamps/Food Warmers

## Inserts/Pans MJCF/Filter Magic

**NOTE:** Holding stations can be equipped with scoop or café pan holding areas. The inserts, which hold the pans in place, are different, depending on the style pan they hold.

### Café Pan Insert

Café pan inserts have rounded corners

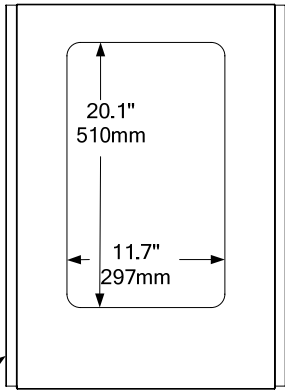

910-7704

### Scoop Pan Insert

Scoop pan inserts have square corners

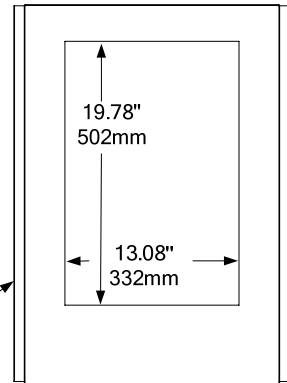

910-7705

### Café Pan Grate

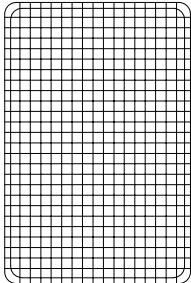

803-0104

Fits all café pan inserts

### Café Pan

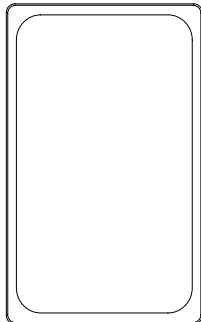

803-0054

Fits all café pan inserts

### Scoop Inset Pan

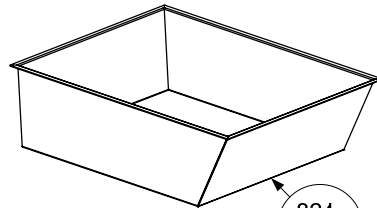

Fits all scoop inserts

824-1960\*

\*Earlier models used a different pan to store a powershower : 826-0993

### Scoop

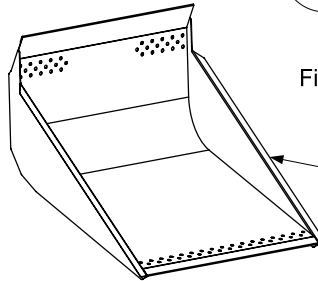

Fits all scoop inserts

823-1865

### Cover

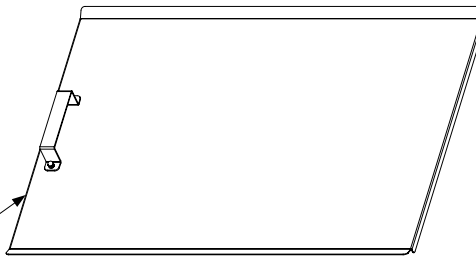

806-1343

Fits scoop or café pan

# Heat Lamps/Food Warmers

## 55 Cabinets

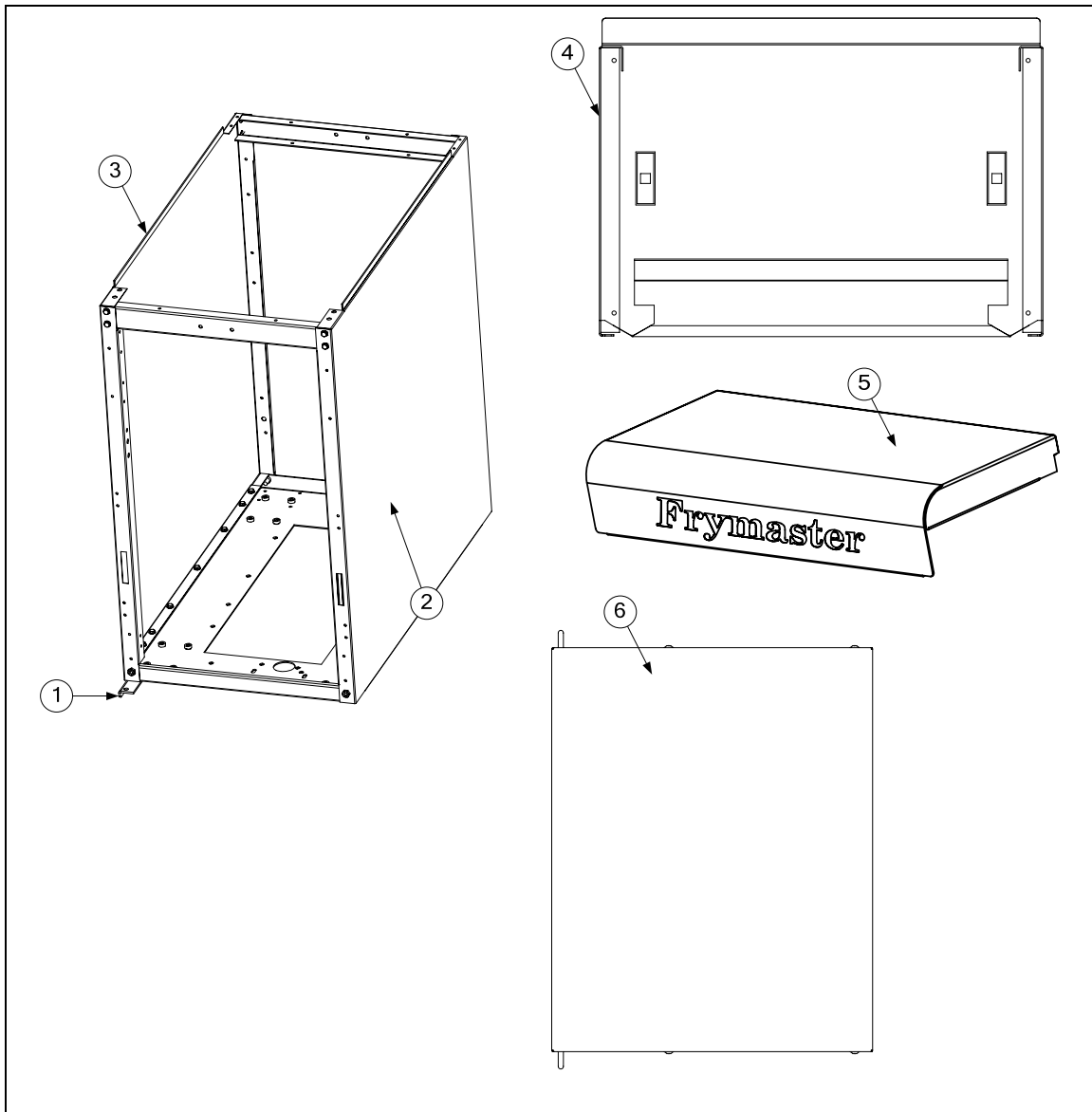

1	230-4685	Hinge, lower
*	106-5124	Base assembly
2	212-6510	Side, RT, stainless
*	202-6633	Side, RT, enamel
3	211-6510SP	Side, LT, stainless
*	201-6633SP	Side. LT, enamel
4	210-5969	Flue cap
5	824-1689	Top cap
6	106-4397	Door

# Heat Lamps/Food Warmers

## 35/45 Cabinets

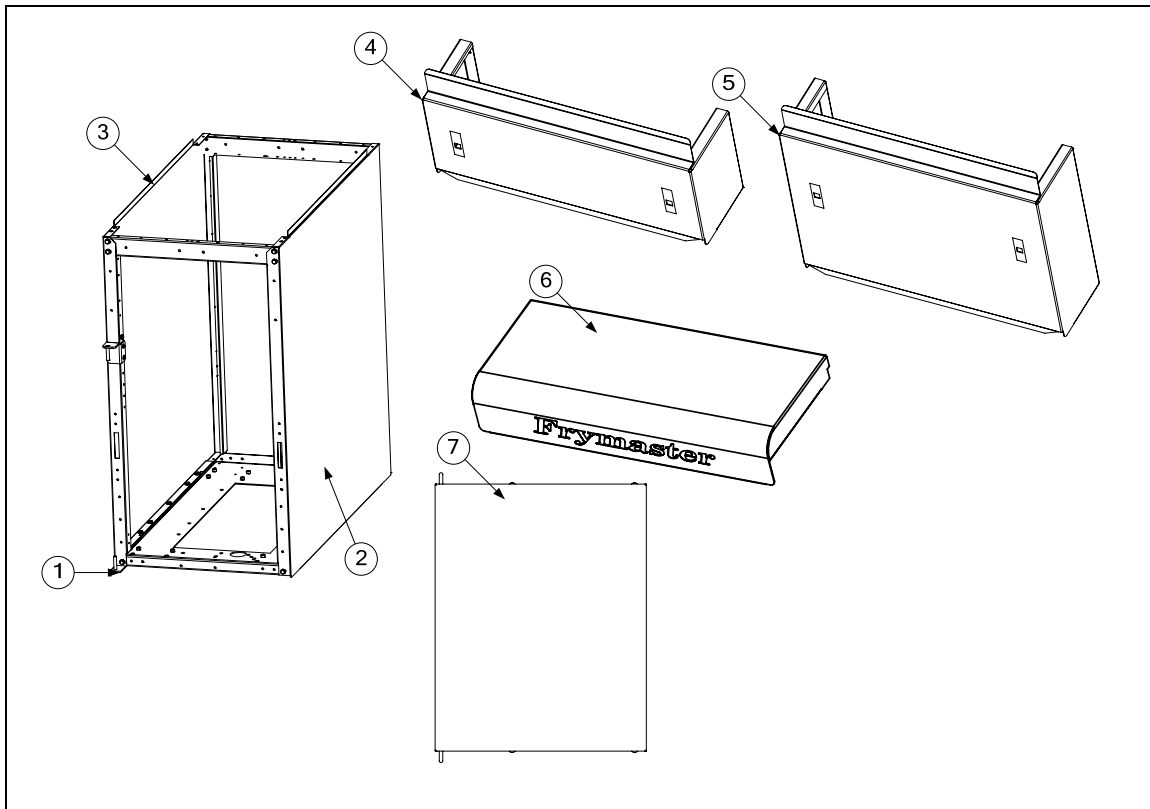

1	823-4713	Hinge, lower
*	106-5440	Base assembly
2	212-6893SP	Side, RT, Stainless
*	202-6917SP	Side, RT, enamel
3	211-6893SP	Side, LT, stainless
*	201-6917SP	Side, LT, enamel
4	210-6811	Flue cap, 35
5	210-6812	Flue cap, 45
6	824-1409	Top cap
7	106-9539	Door

# Heat Lamps/Food Warmers

## RE Cabinets

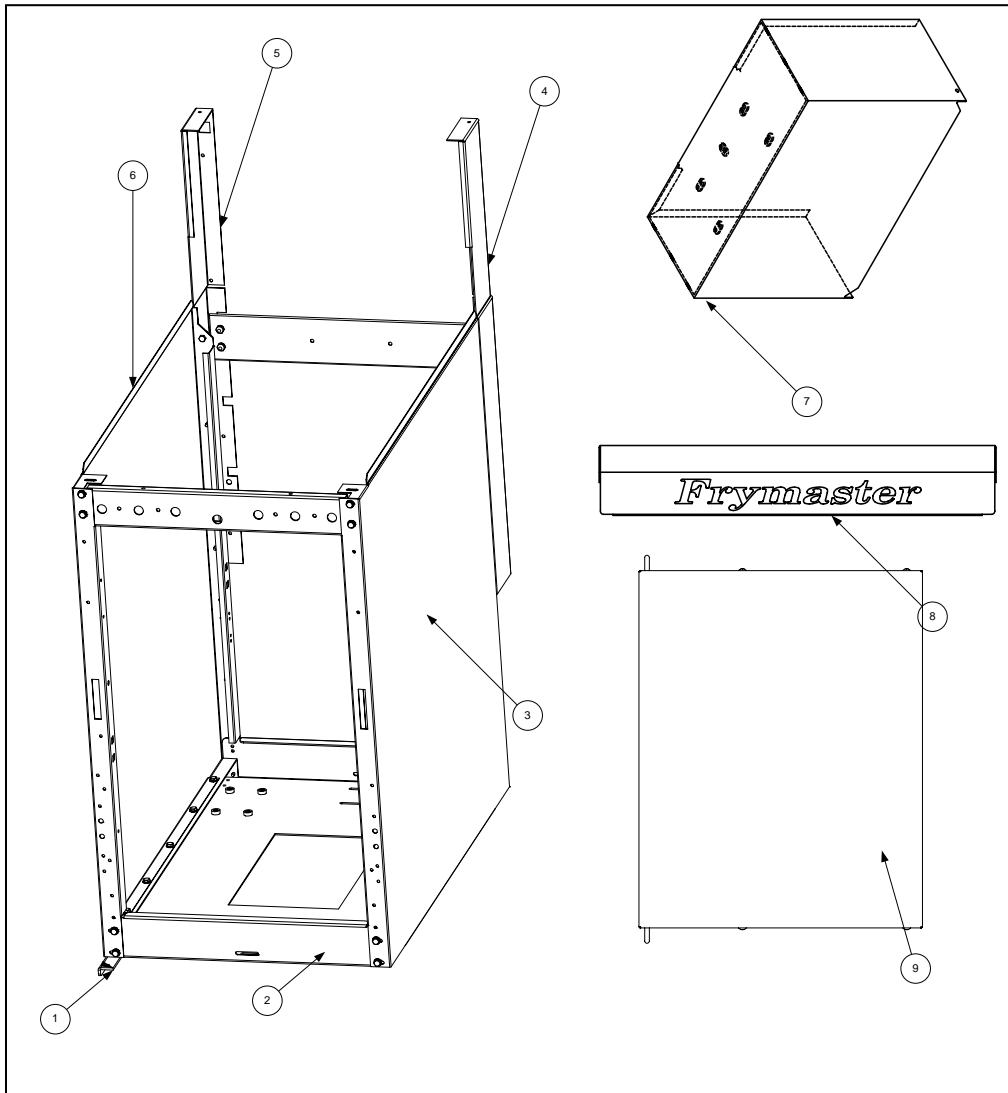

1	230-4685	Hinge, lower
2	106-4901	Base assembly
3	232-0323SP	Side, right SS
*	222-0323SP	Side, RT, enamel
4	106-3829	Upright assembly, RT
5	106-3828	Upright assembly, LT
6	231-0323SP	Side, left
*	221-0323SP	Side, LT, enamel
7	823-2358	Tilt housing
8	106-5195	Top cap
9	106-4397	Door

# Heat Lamps/Food Warmers

## Casters/Legs/Anchors

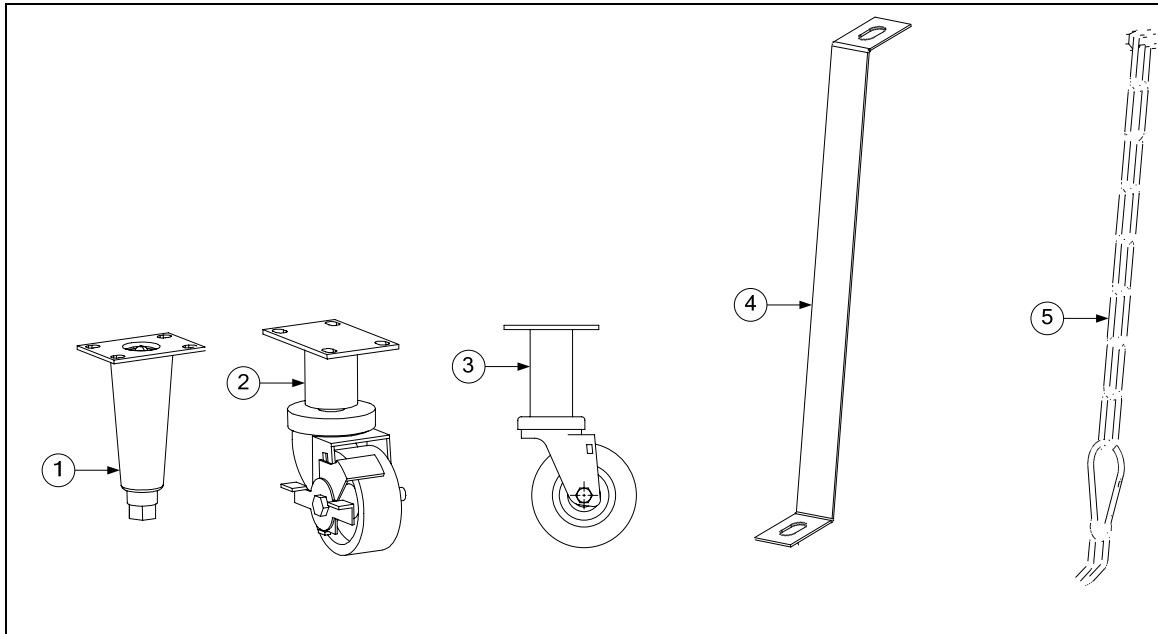

1	810-3169	Leg (set of 4)
2	810-0326	Caster, adjustable, with brake
3	810-1494	Caster, without brake
4	826-1095	Anchor restraint kit
5	826-0900	Chain restraint kit



Shipping Address: 8700 Line Avenue, Shreveport, Louisiana 71106

TEL 1-318-865-1711

FAX (Parts) 1-318-688-2200

(Tech Support) 1-318-219-7135

PRINTED IN THE UNITED STATES

SERVICE HOTLINE  
1-800-551-8633

819-6330  
AUG 09