

**SERVICE AND PARTS MANUAL
FRYMASTER BIEL14 SERIES MANUAL LOV™
ELECTRIC FRYER**



This equipment chapter is to be installed in the Fryer Section of the *Equipment Manual*.

FOR YOUR SAFETY
Do Not Store or use gasoline or other flammable vapors and liquids in the vicinity of this or any other appliance.



**MANUFACTURED
BY**



**8700 Line Avenue.
SHREVEPORT, LOUISIANA 71106
PHONE: 1-318-865-1711
TOLL FREE: 1-800-551-8633
1-800-24 FRYER
FAX: 1-318-219-7135**



Frymaster L.L.C., 8700 Line Avenue, Shreveport, LA 71106
PHONE 318-865-1711 FAX 318-219-7135
SERVICE HOTLINE 1-800-24-FRYER

PRINTED IN THE UNITED STATES

www.frymaster.com

Email: service@frymaster.com

JULY 2012
* 8196963 *

NOTICE

IF, DURING THE WARRANTY PERIOD, THE CUSTOMER USES A PART FOR THIS MANITOWOC FOOD SERVICE EQUIPMENT OTHER THAN AN UNMODIFIED NEW OR RECYCLED PART PURCHASED DIRECTLY FROM FRYMASTER DEAN, OR ANY OF ITS FACTORY AUTHORIZED SERVICERS, AND/OR THE PART BEING USED IS MODIFIED FROM ITS ORIGINAL CONFIGURATION, THIS WARRANTY WILL BE VOID. FURTHER, FRYMASTER DEAN AND ITS AFFILIATES WILL NOT BE LIABLE FOR ANY CLAIMS, DAMAGES OR EXPENSES INCURRED BY THE CUSTOMER WHICH ARISE DIRECTLY OR INDIRECTLY, IN WHOLE OR IN PART, DUE TO THE INSTALLATION OF ANY MODIFIED PART AND/OR PART RECEIVED FROM AN UNAUTHORIZED SERVICE CENTER.

 **DANGER**

Copper wire suitable for at least 167°F (75°C) must be used for power connections.

 **DANGER**

The electrical power supply for this appliance must be the same as indicated on the rating and serial number plate located on the inside of the fryer door.

 **DANGER**

This appliance must be connected to the voltage and phase as specified on the rating and serial number plate located on the inside of the fryer door.

 **DANGER**

All wiring connections for this appliance must be made in accordance with the wiring diagrams furnished with the equipment. Wiring diagrams are located on the inside of the fryer door.

 **DANGER**

Do not store or use gasoline or other flammable vapors and liquids in the vicinity of this or any other appliance.

 **WARNING**

Do not attach accessories to this fryer unless fryer is secured from tipping. Personal injury may result.

 **WARNING**

Frymaster fryers equipped with legs are for permanent installations. Fryers fitted with legs must be lifted during movement to avoid damage and possible bodily injury. For a moveable or portable installation, Frymaster optional equipment casters must be used.

Questions? Call 1-800-551-8633 or email at service@frymaster.com.

 **WARNING**

Do not use water jets to clean this equipment.

 **WARNING**

This equipment is intended for indoor use only. Do not install or operate this equipment in outdoor areas.

⚠ DANGER

Adequate means must be provided to limit the movement of this appliance without depending on or transmitting stress to the electrical conduit. A restraint kit is provided with the fryer. If the restraint kit is missing contact your local KES.

⚠ DANGER

Prior to movement, testing, maintenance and any repair on your Frymaster fryer, disconnect all electrical power from the fryer.

ELECTRICAL POWER SPECIFICATIONS

VOLTAGE	PHASE	WIRE SERVICE	MIN. SIZE	AWG (mm ²)	AMPS PER LEG		
					L1	L2	L3
208	3	3	6	(16)	39	39	39
240	3	3	6	(16)	34	34	34
480	3	3	8	(10)	17	17	17
220/380	3	4	6	(16)	21	21	21
240/415	3	4	6	(16)	20	20	21
230/400	3	4	6	(16)	21	21	21



MANUAL LOV™ SERIES ELECTRIC FRYERS SERVICE AND PARTS TABLE OF CONTENTS

CAUTIONARY STATEMENTS	i
ELECTRICAL POWER SPECIFICATIONS	ii
CHAPTER 1: Service Procedures	
1.1 General	1-1
1.2 Replacing a Controller	1-1
1.3 Replacing Component Box Components	1-1
1.4 Replacing a High-Limit Thermostat	1-3
1.5 Replacing a Temperature Probe	1-3
1.6 Replacing a Heating Element	1-5
1.7 Replacing Contactor Box Components	1-6
1.8 Replacing a Frypot	1-7
1.9 Built-In Filtration System Service Procedures	1-9
1.9.1 Filtration System Problem Resolution	1-9
1.9.2 Replacing the Filter Motor, Filter Pump and Related Components	1-10
1.9.3 Replacing the Filter Transformer or Filter Relay	1-12
1.10 Control Power Reset	1-12
1.11 Manual LOV M3000 Controller Service Procedures	1-13
1.11.1 Manual LOV M3000 Controller Troubleshooting	1-13
1.11.2 Manual LOV M3000 Controller Useful Codes	1-16
1.11.3 Service Required Errors	1-16
1.11.4 Error Log Codes	1-17
1.11.5 Tech Mode	1-17
1.11.6 Manual LOV M3000 Menu Summary Tree	1-18
1.11.7 Manual LOV M3000 Controller Pin Positions and Harnesses	1-19
1.12 Loading and Updating Software	1-20
1.13 Interface Board Diagnostic Chart	1-21
1.14 Probe Resistance Chart	1-22
1.15 Wiring Diagrams	1-23
1.15.1 Manual LOV Simplified Wiring	1-23
1.15.2 Control Wiring w/ Manual LOV M3000 Controller	1-24
1.15.3 Contactor Box-Delta Configuration	1-25
1.15.4 Contactor Box-WYE Configuration	1-26
1.15.5 Simplified BIEL14 Full-Vat Delta Wiring	1-27
1.15.6 Simplified BIEL14 Dual-Vat Delta Wiring	1-28
1.15.7 Simplified BIEL14 Full-Vat Export WYE Wiring	1-29
1.15.8 Simplified BIEL14 Dual-Vat Export WYE Wiring	1-30
1.15.9 BIEL14 Series Data Network Flowchart	1-31
CHAPTER 2: Parts List	
2.1 Accessories	2-1
2.2 Doors, Sides, Tilt Housings, Top Caps and Casters	2-2
2.3 Drain System Components	2-3
2.3.1 Drain Tube Sections and Associated Parts	2-3

MANUAL LOV™ SERIES ELECTRIC FRYERS SERVICE AND PARTS

TABLE OF CONTENTS cont.

2.3.2	Drain Valve Assembly	2-5
2.4	Electronics and Wiring Components	2-6
2.4.1	Component Boxes	2-6
2.4.2	Contactors	2-8
2.4.3	Heating Element Assemblies and Hardware	2-10
2.4.4	Element Tube Assemblies	2-12
2.4.5	Controllers	2-12
2.4.6	Wiring	2-13
2.4.6.1	Contactors 12-Pin Dual Vat	2-13
2.4.6.2	Contactors 12-Pin Full Vat	2-13
2.4.6.3	Contactors 6-Pin Left Element	2-14
2.4.6.4	Contactors 9-Pin Right Element	2-14
2.4.6.5	Main Wiring Harnesses	2-15
2.4.6.6	Component Box, Filter Pump and Basket Lift Wiring Harnesses	2-16
2.4.6.7	Component Box to Filter Pump Harness	2-16
2.4.6.8	Interface Board to Controller Wiring Harness 15-Pin	2-17
2.4.6.9	Manual LOV M3000 Wiring Harnesses	2-17
2.5	Filtration System Components	2-18
2.6	Filter Pump, Motor and Associated Components	2-19
2.7	Frypot Assemblies and Associated Parts	2-20
2.8	Oil Return System Components	2-21
2.9	Wiring Connectors, Pin Terminals and Power Cords	2-22
2.10	Fasteners	2-23

MANUAL LOV™ ELECTRIC WARRANTY STATEMENT

Frymaster, L.L.C. makes the following limited warranties to the original purchaser only for this equipment and replacement parts:

A. WARRANTY PROVISIONS - FRYERS

1. Frymaster L.L.C. warrants all components against defects in material and workmanship for a period of two years.
2. All parts, with the exception of the frypot, O-rings and fuses, are warranted for two years after installation date of fryer.
3. If any parts, except fuses and filter O-rings, become defective during the first two years after installation date, Frymaster will also pay straight-time labor costs up to two hours to replace the part, plus up to 100 miles/160 km of travel (50 miles/80 km each way).

B. WARRANTY PROVISIONS - FRYPOTS

The frypot has a lifetime parts and labor warranty. If a frypot develops a leak after installation, Frymaster will replace the frypot, allowing up to the maximum time per the Frymaster time allowance chart hours of straight-time labor. Components attached to the frypot, such as the high-limit, probe, gaskets, seals, and related fasteners, are also covered by the lifetime warranty if replacement is necessitated by the frypot replacement. Leaks due to abuse or from threaded fittings such as probes, sensors, high-limits, drain valves or return piping are not included.

C. PARTS RETURN

All defective in-warranty parts must be returned to a Frymaster Factory Authorized Servicer within 60 days for credit. After 60 days, no credit will be allowed.

D. WARRANTY EXCLUSIONS

This warranty does not cover equipment that has been damaged due to misuse, abuse, alteration, or accident such as:

- improper or unauthorized repair (including any frypot which is welded in the field);
- failure to follow proper installation instructions and/or scheduled maintenance procedures as prescribed in your MRC cards. Proof of scheduled maintenance is required to maintain the warranty;
- improper maintenance;
- damage in shipment;
- abnormal use;
- removal, alteration, or obliteration of either the rating plate or the date code on the heating elements;
- operating the frypot without shortening or other liquid in the frypot;

- no fryer will be warranted under the ten-year program for which a proper start-up form has not been received.

This warranty also does not cover:

- transportation or travel over 100 miles/160 km (50 miles/80 km each way), or travel over two hours;
- overtime or holiday charges;
- consequential damages (the cost of repairing or replacing other property which is damaged), loss of time, profits, use or any other incidental damages of any kind.

There are no implied warranties of merchantability or fitness for any particular use or purpose.

This warranty is applicable at the time of this printing and is subject to change.

MANUAL LOV™ SERIES ELECTRIC FRYERS

CHAPTER 1: SERVICE PROCEDURES

1.1 General

Before performing any maintenance on your Frymaster fryer, disconnect the fryer from the electrical power supply.

WARNING

To ensure the safe and efficient operation of the fryer and hood, the electrical plug must be fully engaged and locked in its pin and sleeve socket.

When electrical wires are disconnected, it is recommended that they be marked in such a way as to facilitate re-assembly.

1.2 Replacing the Controller

1. Disconnect the fryer from the electrical power supply.
2. Open the control panel by removing the screws on the bottom of the bezel. Carefully lower the bezel.
3. Remove the two screws from the upper corners of the controller. The controller is hinged at the bottom and will swing open from the top.
4. Unplug the wiring harnesses from the connectors on the back of the controller, marking their position for reassembly, and disconnect the grounding wires from the terminals. Remove the controller by lifting it from the hinged slots in the control panel frame.

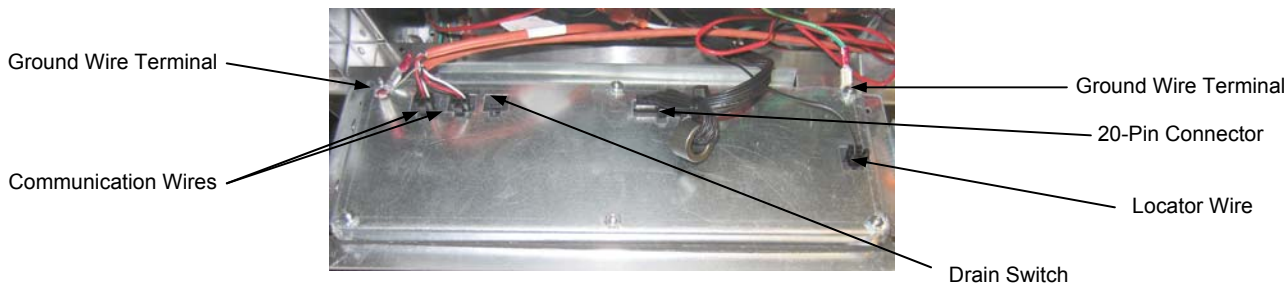

5. Install the replacement controller. Reverse steps 1 thru 4.
6. Setup the controller following the instructions on page 2-9 in the Controller Operation manual. Setup **MUST** be performed after replacement.
7. Once setup is complete on all replaced controllers, reset all control power following the instructions in section 1.10 on page 1-12 to readdress the new M3000 controller. Check software version and if necessary update the software. If a software update was necessary, follow the instructions to update the software in section 1.12 on page 1-20.

1.3 Replacing Component Box Components

1. Disconnect the fryer from the electrical power supply.

2. Open the control panel by removing the screws on the bottom of the bezel. Carefully lower the bezel.
3. Remove the two screws from the upper corners of the control panel and allow the control panel to swing down.
4. Unplug the wiring harnesses and disconnect the grounding wires from the terminals on the back of the controller. Remove the control panel assembly by lifting it from the hinge slots in the control panel frame.
5. Disconnect the wiring from the component to be replaced, being sure to make a note of where each wire was connected.
6. Dismount the component to be replaced and install the new component, being sure that any required spacers, insulation, washers, etc. are in place.

NOTE: If more room to work is required, the control panel frame assembly may be removed by removing the hex-head screws, which secure it to the fryer cabinet (see illustration below). If this option is chosen, all control panel assemblies must be removed per steps 1 and 2 above. The cover plate, on the lower front of the component box, may also be removed to allow additional access if desired. *Removing the component box itself from the fryer is not recommended due to the difficulty involved in disconnecting and reconnecting the oil-return valve rods, which pass through openings in the component box.*

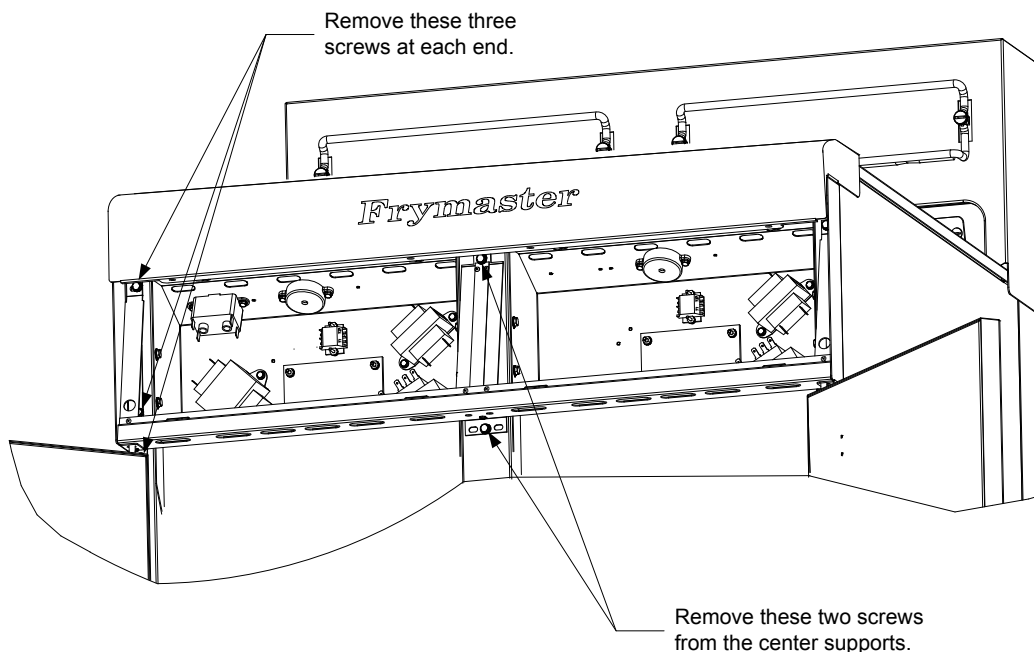

Removing the Control Panel Frame and Top Cap Assembly

7. Reconnect the wiring disconnected in step 5, referring to your notes and the wiring diagrams on the fryer door to ensure that the connections are properly made. Also, verify that no other wiring was disconnected accidentally during the replacement process.
8. Reverse steps 1 through 4 to complete the replacement and return the fryer to service.

1.4 Replacing a High-Limit Thermostat

1. Drain the frypots into a Shortening Disposal Unit (SDU) or other appropriate **METAL** container.



DANGER

DO NOT drain more than one full frypot into the SDU at one time.

2. Disconnect the fryer from the electrical power supply and reposition it to gain access to the rear of the fryer.
3. Remove the screws from the bottom of the lower back panel attaching the contactor plug guards.
4. Remove each of the guards.
5. Remove the four screws from both the left and right sides of the lower back panel.
6. Locate the high-limit that is being replaced and follow the two-black wires to the 12-pin connector C-6. Note where the leads are connected prior to removing them from the connector. Unplug the 12-pin connector C-6 and using a pin-pusher push the pins of the high-limit out of the connector.
7. Carefully unscrew the high-limit thermostat to be replaced.
8. Apply Loctite™ PST 567 or equivalent sealant to the threads of the replacement and screw it securely into the frypot.
9. Insert the leads into the 12-pin connector C-6 (see illustration below). For full-vat units or the right half of a dual-vat unit the leads go into positions 1 and 2 of the connector. For the left half of a dual-vat unit, the leads go into positions 7 and 8. In either case, polarity does not matter.

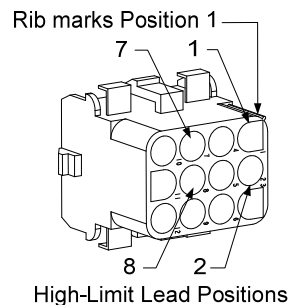

10. Reconnect the 12-pin connecting plug C-6. Use wire ties to secure any loose wires.
11. Reinstall the back panels, contactor plug guards, reposition the fryer under the exhaust hood, and reconnect it to the electrical power supply to return the fryer to service.

1.5 Replacing a Temperature Probe

1. Disconnect the fryer from the electrical power supply and reposition it to gain access to the rear of the fryer.
2. Remove each of the guards.
3. Remove the four screws from both sides of the lower back panel. Then remove the two screws on both the left and right sides of the back of the tilt housing. Lift the tilt housing straight up to remove from the fryer.

4. Locate the red and white wires of the temperature probe to be replaced. Note where the leads are connected prior to removing them from the connector. Unplug the 12-pin connector C-6 and using a pin-pusher push the pins of the temperature probe out of the connector.
5. Raise the element and remove the securing probe bracket and metal tie wraps that secure the probe to the element (see illustration below). Remove the ground clip on the probe shield.

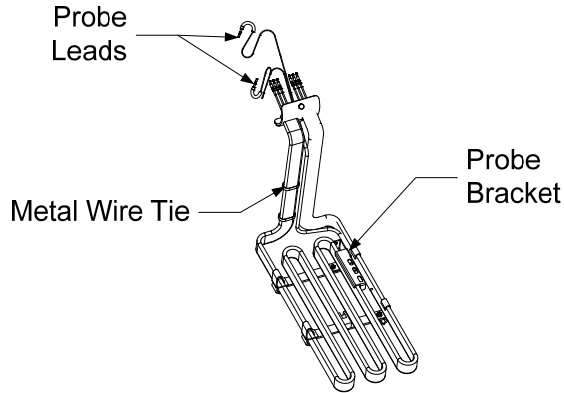

6. Gently pull on the temperature probe and grommet, pulling the wires up the rear of the fryer and through the element tube assembly.
7. Insert the replacement temperature probe (wires first) into the tube assembly ensuring that the grommet is in place. Secure the probe to the elements using the bracket which was removed in Step 5 and the metal tie wraps which were included in the replacement kit.
8. Route the probe wires out of the tube assembly following the element wires down the back of the fryer through the Heyco bushings to the 12-pin connector C-6. Secure the wires to the sheathing with wire ties. Attach the ground clip.
9. Insert the temperature probe leads into the 12-pin connector C-6 (see illustration below). For full-vat units or the right half of a dual-vat unit the red (or yellow) lead goes into position 3 and the white lead into position 4 of the connector. For the left half of a dual-vat unit, the red (or yellow) lead goes into position 9 and the white lead into position 10. **NOTE: Right and left** refer to the fryer as viewed from the front.

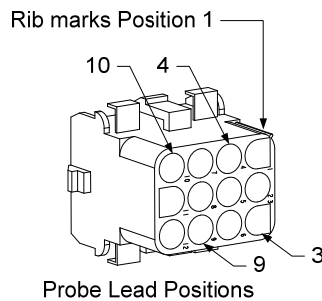

10. Secure any loose wires with wire ties, making sure there is no interference with the movement of the springs. Rotate the elements up and down, making sure movement is not restricted and that the wires are not pinched.
11. Reinstall the tilt housing, back panels and contactor plug guards. Reposition the fryer under the exhaust hood, and reconnect it to the electrical power supply to return the fryer to service.

1.6 Replacing a Heating Element

1. Perform steps 1-5 of section 1.5, *Replacing a Temperature Probe*.
2. Disconnect the wire harness containing the probe wiring. Using a pin pusher, disconnect the probe wires from the 12-pin connector C-6.
3. In the rear of the fryer, disconnect the 6-pin connector for the left element (as viewed from the front of the fryer) or the 9-pin connector for the right element from the contactor box. Press in on the tabs on each side of the connector while pulling outward on the free end to extend the connector and release the element leads (see photo below). Pull the leads out of the connector and out of the wire sleeving.

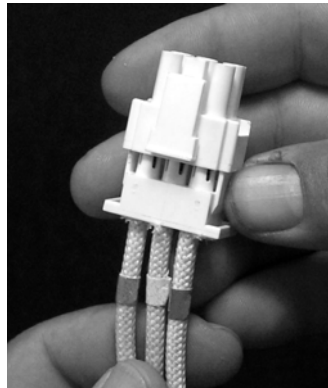

4. Raise the element to the full up position and support the elements.
5. Remove the hex head screws and nuts that secure the element to the tube assembly and pull the element out of the frypot. **NOTE:** The nuts inside the tube can be held and removed using the RE element tube nut spanner, PN# 2304028. Full-vat elements consist of two dual-vat elements clamped together. For full-vat units, remove the element clamps before removing the nuts and screws that secure the element to the tube assembly.
6. If applicable, recover the probe bracket and probe from the element being replaced and install them on the replacement element. Install the replacement element in the frypot, securing it with the nuts and screws removed in Step 5 to the tube assembly. Ensure the gasket is between the tube and element assembly.
7. Route the element leads through the element tube assembly and into the wire sleeving to prevent chafing. Ensure that the wire sleeving is routed back through the Heyco bushings, keeping it clear from the lift springs. Also ensure that the wire sleeving extends into the tube assembly, protecting the wires. Press the pins into the connector in accordance with the diagram on the following page, and then close the connector to lock the leads in place. **NOTE:** It is critical that the wires be routed through the sleeving to prevent chafing.

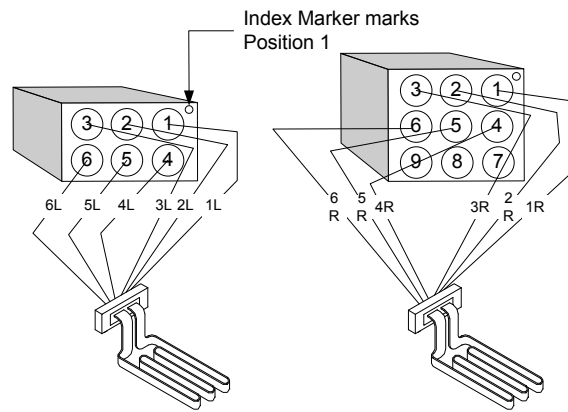

8. Reconnect the element connector ensuring that the latches lock.
9. Insert the temperature probe leads into the 12-pin wiring harness connector (see illustration below). For full-vat units or the right half of a dual-vat unit, the red lead goes into position 3 and the white into position 4. For the left half of a dual-vat unit, the red lead goes into position 9 and the white into position 10. **NOTE: *Right* and *left* refer to the fryer as viewed from the front.**

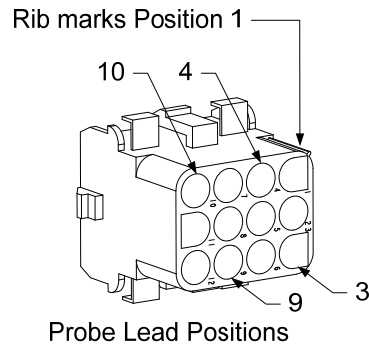

10. Reconnect the 12-pin connector C-6 of the wiring harness disconnected in Step 2.
11. Lower the element onto the basket rack.
12. Reinstall the tilt housing, back panels and contactor plug guard. Reposition the fryer under the exhaust hood, and reconnect it to the electrical power supply.

1.7 Replacing Contactor Box Components

1. If replacing a contactor box component, remove the filter pan and lid from the unit.
2. Disconnect the fryer from the electrical power supply.
3. Remove the two screws securing the cover of the contactor box. The contactor boxes above the filter pan are accessed by sliding under the fryer. They are located to the left and right above the guide rails (see photo below). The contactor boxes for frypots not over the filter pan are accessed by opening the fryer door directly under the affected frypot (see photo on following page).

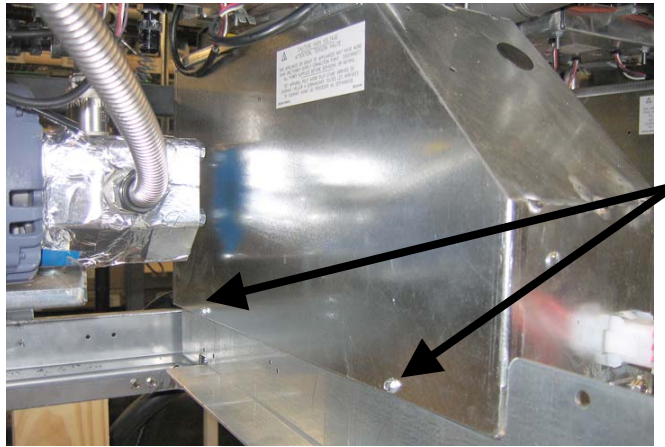

Remove two screws to access contactor box components above the filter pan.

4. The contactors and relays are held on by threaded pin studs so that only removal of the nut is required to replace the component.
5. After performing necessary service, reverse steps 1-4 to return the fryer to operation.



Left and right views of mechanical contactor box components.

1.8 Replacing a Frypot

1. Drain the frypot into the filter pan or, if replacing a frypot over the filter system, into a Shortening Disposal Unit (SDU) or other appropriate **METAL** container. If replacing a frypot over the filter system, remove the filter pan and lid from the unit.

⚠ DANGER

DO NOT drain more than one full frypot into the SDU at one time.

2. Disconnect the fryer from the electrical power supply and reposition it to gain access to both the front and rear.
3. Open the control panel by removing the two screws on the bottom of the bezel. Carefully lower the bezel.
4. Remove the two screws from the upper corners of the control panels and allow them to swing down (see photo on page 1-1).

5. Unplug the wiring harnesses and ground wires from the backs of the controllers. Remove the controllers by lifting them from the hinge slots in the control panel frame.
6. Remove the screws from the bottom of the lower back panel attaching the contactor plug guards.
7. Remove each of the guards
8. Remove the tilt housing and back panels from the fryer. The tilt housing must be removed first in order to remove the upper back panel.
9. To remove the tilt housing, remove the hex head screws from the rear edge of the housing. The housing can be lifted straight up and off the fryer.
10. Remove the control panel by removing the screws on both sides.
11. Loosen the component boxes by removing the screws, which secure them in the cabinet.
12. Remove the top cap by removing the nuts at each end that secure it to the cabinetry.
13. Remove the hex head screw that secures the front of the frypot to the cabinet cross brace.
14. Remove the top-connecting strip that covers the joint with the adjacent frypot.
15. Unscrew the nut located on the front of each section of drain tube, and remove the tube assembly from the fryer.
16. Remove the covers from the drain safety switch(es) and disconnect the wiring at the switch(es).
17. Disconnect any auto top-off sensors if equipped and wiring.
18. At the rear of the fryer, unplug the 12-pin connector C-6 and, using a pin pusher, disconnect the high-limit thermostat leads.
19. Disconnect the oil return and top off flexline(s).
20. Raise the elements to the “up” position and disconnect the element springs.
21. Remove the machine screws and nuts that secure the element tube assembly to the frypot. Carefully lift the element assembly from the frypot and secure it to the cross brace on the rear of the fryer with wire ties or tape.
22. Carefully lift the frypot from the fryer and place it upside down on a stable work surface.
23. Recover the drain valve(s), oil return flexline connection fitting(s), auto top-off sensors if equipped and high-limit thermostat(s) from the frypot. Clean the threads and apply Loctite™ PST 567 or equivalent sealant to the threads of the recovered parts and install them in the replacement frypot.
24. Carefully lower the replacement frypot into the fryer. Reinstall the hex head screw removed in step 9 to attach the frypot to the fryer.
25. Position the element tube assembly in the frypot and reinstall the machine screws and nuts removed in step 21.

26. Reconnect the oil return and auto top off flexlines to the frypot, and replace aluminum tape, if necessary, to secure heater strips to the flexlines.
27. Insert the high-limit thermostat leads disconnected in step 18 (see illustration on page 1-3 for pin positions).
28. Reconnect the auto top-off sensors.
29. Reconnect the drain safety switch wiring to the switch(es) in accordance with the diagram below then reinstall the switch covers.

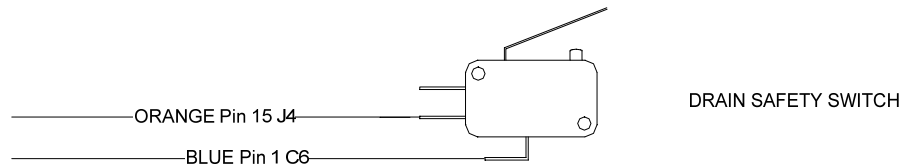

30. Reinstall the drain tube assembly.
31. Reinstall the top connecting strips, top cap, tilt housing, back panels and contactor plug guards.
32. Reinstall controllers in the control panel frame and reconnect the wiring harnesses and ground wires.
33. Reposition the fryer under the exhaust hood and reconnect it to the electrical power supply.

1.9 Built-in Filtration System Service Procedures

1.9.1 Filtration System Problem Resolution

One of the most common causes of filtration problems is placing the filter paper on the bottom of the filter pan rather than over the filter screen.

CAUTION

Ensure that filter screen is in place prior to filter paper placement and filter pump operation. Improper screen placement is the primary cause of filtration system malfunction.

Whenever the complaint is “the pump is running, but no oil is being filtered,” check the installation of the filter paper, and ensure that the correct size is being used. While you are checking the filter paper, verify that the O-rings on the pick-up tube of the filter pan are in good condition. A missing or worn O-ring allows the pump to take in air and decrease its efficiency.

If the pump motor overheats, the thermal overload will trip and the motor will not start until it is reset. If the pump motor does not start, press the red reset switch (button) located on the rear of the motor.

If the pump starts after resetting the thermal overload switch, then something is causing the motor to overheat. A major cause of overheating is when several frypots are filtered sequentially, overheating the pump and motor. Allow the pump motor to cool at least 30 minutes before resuming operation. Pump overheating can be caused by:

- Solidified shortening in the pan or filter lines, or
- Attempting to filter unheated oil or shortening (cold oil and shortening are more viscous, overloading the pump motor and causing it to overheat).

If the motor runs but the pump does not return oil, there is a blockage in the pump. Incorrectly sized or installed paper will allow food particles and sediment to pass through the filter pan and into the pump. When sediment enters the pump, the gears bind, causing the motor to overload, again tripping the thermal overload. Shortening that has solidified in the pump will also cause it to seize, with the same result.

A pump seized by debris or hard shortening can usually be freed by manually moving the gears with a screwdriver or other instrument.

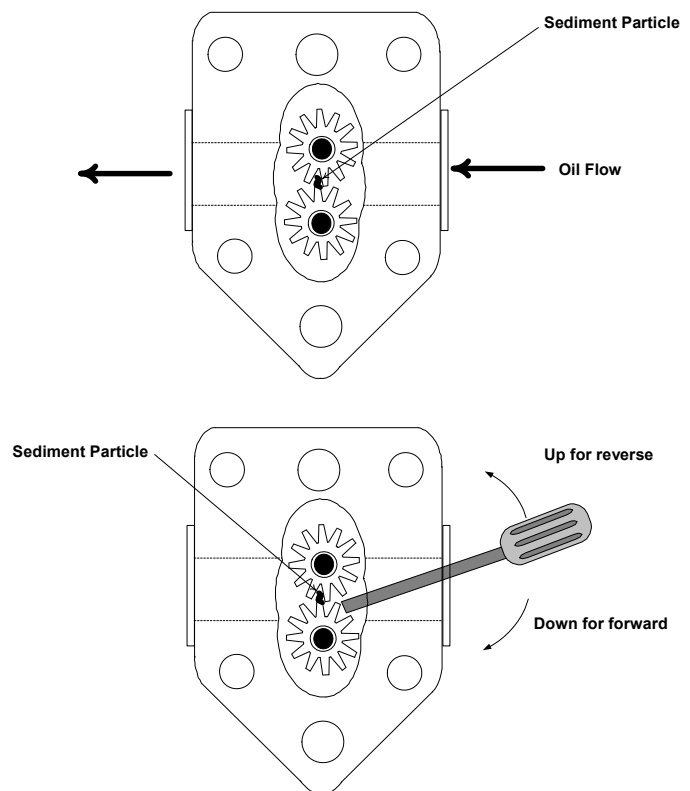

Disconnect power to the filter system, remove the input plumbing from the pump, and use a screwdriver to manually turn the gears.

- Turning the pump gears in reverse will release a hard particle.
- Turning the pump gears forward will push softer objects and solid shortening through the pump and allow free movement of the gears.

Incorrectly sized or installed paper/pads will also allow food particles and sediment to pass through and clog the suction tube on the bottom of the filter pan. Particles large enough to block the suction tube may indicate that the crumb tray is not being used. Pan blockage can also occur if shortening is left in the pan and allowed to solidify. Blockage removal can be accomplished by forcing the item out with an auger or drain snake. Compressed air or other pressurized gases should not be used to force out the blockage.

1.9.2 Replacing the Filter Motor, Filter Pump, and Related Components

1. Remove the filter pan and lid from the unit. Drain the frypots into a Shortening Disposal Unit (SDU) or other appropriate metal container.

⚠ DANGER
DO NOT drain more than one full frypot into the SDU at one time.

2. Disconnect the fryer from the electrical power supply and reposition it to gain access to both the front and rear.

3. Disconnect the flexline running to the oil-return manifold at the rear of the fryer as well as the pump suction flexline at the end of the filter pan connection (see photo below). On some models a third flexline may need to be disconnected.

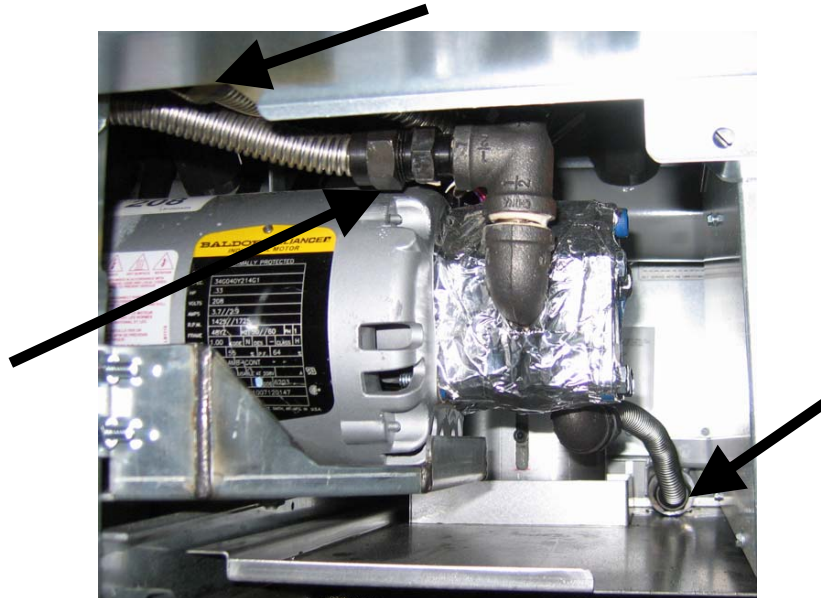

Disconnect flexlines indicated by the arrows.

4. Loosen the nut and bolt that secures the bridge to the oil-return manifold.
5. Remove the cover plate from the front of the motor and disconnect the motor wires.
6. Unplug the pump motor assembly 6-pin connector C-2.
7. Remove the two nuts and bolts which secure the front of the bridge to the cross brace and carefully slide the bridge rearward off the cross brace until its front end can be lowered to the floor. Undo the single nut holding it in place in back. Be careful not to let the rear of the bridge slip off the manifold at this point.
8. Get a good grip on the bridge, carefully pull it forward off the oil-return manifold, and lower the entire assembly to the floor. Once on the floor, pull the assembly out the front of the fryer.
9. When required service has been completed, reverse steps 3-8 to reinstall the bridge. **NOTE:** The black motor wires go on the top terminal, the white on the bottom. The red/black heater tape wires go into position 3 and the violet/white wires go into position 6 (see illustration below).

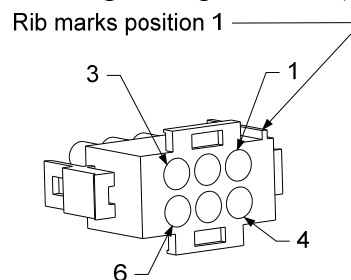

Heater Lead Positions

10. Reconnect the unit to the electrical power supply, and verify that the pump is functioning correctly (i.e., when a filter handle is placed in the ON position, the motor should start and there should be strong suction at the intake fitting and outflow at the rear flush port.)

11. When proper operation has been verified, reinstall the back panels and the filter pan and lid.
12. Reposition the fryer under the exhaust hood and reconnect it to the electrical power supply, if necessary to return the fryer to service.

1.9.3 Replacing the Transformer or Filter Relay

Disconnect the fryer from the electrical power supply. Remove the left controller from the fryer to expose the interior of the left component box. The transformer and relay on the left are located as shown in the illustration below. **NOTE:** The right component box is identical to the left except that the transformer and relay on the left side are not present. Once replaced, reconnect the power.

When replacing a filter relay in the left component box, ensure the 24VAC relay (8070670) is used on 208-240V units and 8070012 is used on 120V units. This relay is the same relay used in the RE fryers.

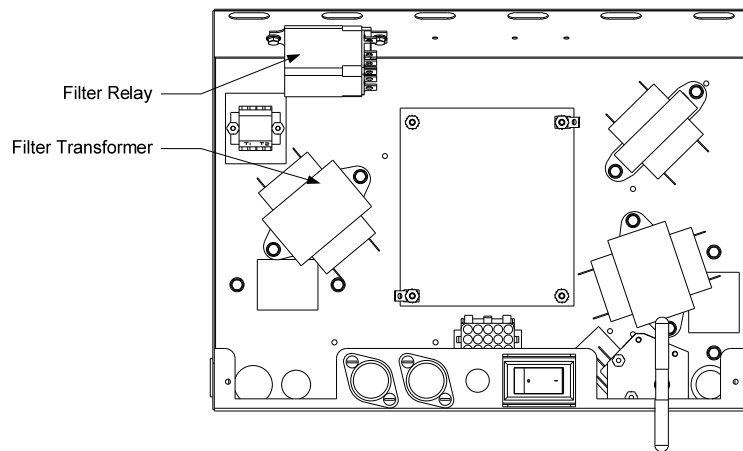

1.10 Control Power Reset Switch

The control power reset switch is a momentary rocker switch located behind the control box, (see Figures 6 and 7) beneath the far right controller, which resets all power to all the controllers and boards in the fryer. It is necessary to reset all power after replacing any controller or board. Press and hold the switch for at least ten seconds when resetting the control power to ensure power has sufficiently drained from boards.



Figure 6

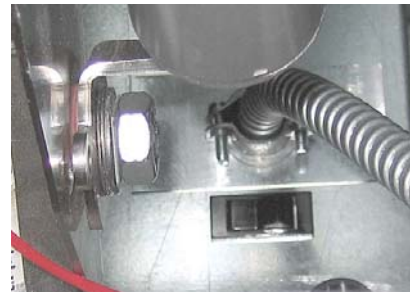

Figure 7 (Rear view of Control Box)

1.11 M3000 Controller Service Procedures

1.11.1 M3000 Controller Troubleshooting

Problem	Probable Causes	Corrective Action
<p>No Display on Controller.</p>	<p>A. Controller not turned on. B. No power to the fryer. C. Power switch turned off. D. Loose fuse holder. E. Controller has failed. F. Damaged controller wiring harness. G. Power supply component or interface board has failed.</p>	<p>A. Press the ON/OFF switch to turn the controller on. B. Verify controller power cord is plugged in and that circuit breaker is not tripped. C. Some fryers have a rocker power switch inside the cabinet below the controller. Ensure the switch is turned on. D. Ensure fuse holder is screwed in properly. E. Swap the controller with a controller known to be good. If controller functions, replace the controller. F. Swap with a harness known to be good. If controller functions, replace the harness. G. If any component in the power supply system (including the transformer and interface board) fail, power will not be supplied to the controller and it will not function.</p>
<p>M3000 display shows FILTER BUSY.</p>	<p>A. Another filtration cycle is still in process.</p>	<p>A. Wait until the previous filtration cycle ends to start another filtration cycle. This may take up to one minute. If filter busy is still displayed with no activity, remove and restore ALL power to the fryer.</p>
<p>M3000 display shows RECOVERY FAULT.</p>	<p>Recovery time exceeded maximum time limit for two or more cycles.</p>	<p>Silence the alarm by pressing the ✓ button. Check that fryer is heating properly. Maximum recovery for electric is 1:40. If this error continues to appear call your ASA.</p>
<p>M3000 display is in wrong temperature scale (Fahrenheit or Celsius).</p>	<p>Incorrect display option programmed.</p>	<p>Fryers using the M3000 controller can toggle between F° to C° by pressing and holding the ◀ and ▶ simultaneously for TEN seconds; three chirps sound. The computer displays TECH MODE. Enter 1658. The controller displays OFF. Turn the controller on to check temperature. If the desired scale is not displayed, repeat.</p>

Problem	Probable Causes	Corrective Action
M3000 displays SERVICE REQUIRED followed by the error .	An error has occurred.	Press YES to silence alarm. The error is displayed three times. See list of issues in section 1.14.3. Fix issue. The computer displays SYSTEM ERROR FIXED? YES/NO. Press YES. Computer displays ENTER CODE. Enter 1111 to clear error code. Pressing NO will allow the fryer to cook but the error will be redisplayed every 15 minutes.
Controller displays CHANGE FILTER PAPER?	Daily filter paper change prompt has occurred.	Press ▲ (YES), follow prompts and change the filter paper.
M3000 display shows HOT-HI-1.	Frypot temperature is more than 410°F (210°C) or, in CE countries, 395°F (202°C).	This is an indication of a malfunction in the temperature control circuitry, including a failure of the high-limit thermostat.
M3000 display shows HI-LIMIT.	Controller in high-limit test mode.	This is displayed only during a test of the high-limit circuit and indicates that the high-limit has opened properly.
M3000 display shows LOW TEMP alternating with MLT-CYCL.	Frypot temperature is below 180°F (82°C).	This display is normal when the fryer is first turned on while in the melt cycle mode. To bypass the melt cycle press and hold either #1 or #2 cook button under the LCD display until a chirp is heard. The computer displays EXIT MELT alternating with YES NO. Press the #1 YES button to exit melt. If the display continues, the fryer is not heating.
M3000 display shows LOW TEMP	Frypot temperature is above 180°F (82°C) and below setpoint.	This display is normal when the fryer is heating and out of melt cycle until the temperature reaches 15° to 20°F of setpoint.
Controller displays LOW TEMP with an alarm.	Frypot temperature has dropped more than 40°F (17°C) for M3000 controllers below setpoint in idle mode or 45°F (25°C) in cook mode.	This display is normal for a short while if a large batch of frozen product is added to the frypot or if the fryer is not heating properly.
M3000 display shows LOW TEMP, heating indicator cycles on and off normally but fryer does not heat.	A. Failed controller. B. Damaged controller wiring harness.	A. Replace controller. B. Replace controller wiring harness.
M3000 display shows TEMP PROBE FAILURE.	Problem with the temperature measuring circuitry including the probe.	This indicates a problem within the temperature probe circuitry. Check resistance of probe, if faulty replace probe.
M3000 display shows PROBE FAILURE with alarm sounding.	Damaged controller wiring harness or connector.	Swap the controller wiring harness with one known to be good. If problem is corrected replace harness.

Problem	Probable Causes	Corrective Action
Controller will not go into program mode or some buttons do not actuate.	Failed controller.	Replace controller
M3000 display shows HI 2 BAD.	Controller in high-limit test mode.	This is displayed only during a test of the high-limit circuit and indicates that the high-limit has failed.
M3000 display shows HEATING FAILURE with alarm sounding. Heating indicator is on, but fryer is not heating.	Failed controller, failed interface board or open high limit thermostat.	Check high limit thermostat, interface board and controller.
M3000 display shows HEATING FAILURE and alarm sounds, but fryer operates normally (false alarm).	Failed controller.	Replace controller.
M3000 display shows CLOSE DRAIN VALVE.	Drain valve is open or switch is out of adjustment or failed.	Ensure all drain valves are completely closed and that microswitches are adjusted and working.
M3000 display shows ERROR RM SDCRD	Defective SD Card	Replace card with another card.
M3000 display shows CALL TECH	Typically shown during software update. Also may be that parameter data has been corrupted or lost.	Press the FILTER button to bypass and continue.

1.11.2 M3000 Controller Useful Codes

To enter any of the following codes: Press and hold ◀ and ▶ simultaneously for **TEN** seconds; three chirps sound. The computer displays **TECH MODE**. Enter the codes below to perform the function.

- **1658 – Change from F° to C°** The computer displays **OFF**. Turn the computer on and check temperature to see the temperature scale. If the desired scale is not displayed, repeat.
- **3322 – Reset Factory Menu** The computer displays **COMPLETE** and then **OFF**. (**NOTE:** This will delete any hand-entered menu items).
- **1650 – Enter Tech Mode.** See page 1-36 to reset passwords and change filter pad time.
- **1212 – Switch between Domestic Menu and International Menu .** The computer displays **COMPLETE** and then **OFF**. (**NOTE:** This will delete any hand-entered menu items).
- **0469 – Reset FILTER STAT DATA**

The following codes require the removal and reinsertion of the J3 locator plug on the rear of the computer before entering the code.

- **1000 – Reset CALL TECH Message** - Disconnect board locator plug (J3). Reinsert plug. Enter **1000**. Computer display switches to **OFF**. Remove and then restore power to the computer using the 20-pin plug.
- **9988 – Reset BADCRC Message** - Disconnect board locator plug (J3). Reinsert plug. Enter **9988**. Computer display switches to **OFF**. Remove and then restore power to the computer using the 20-pin plug.

The following codes are entered when prompted to do so or from an energy misconfigured exception error.

- **1111 – Reset SERVICE REQUIRED Message** – Enter when the issue is fixed and prompted to enter.
- **1234 – Enter SETUP MODE** from energy misconfigured exception error (This usually can be done without pressing the filter buttons if an error is displayed.)

PASSWORDS

To enter level one, level two passwords: Press and hold the **TEMP** and **INFO** buttons simultaneously until level 1 or level 2 is displayed. Release the buttons and **ENTER CODE** appears.

- **1234 – Fryer Setup, Level One and Level Two**
- **4321 – Usage Password** (resets usage statistics).

1.11.3 Service Required Errors

A SERVICE REQUIRED error alternating with YES displays on the computer. After YES is pressed the alarm is silenced. The computer displays an error message from the list below three times with the location of the error. Then the computer displays SYSTEM ERROR FIXED? YES/NO. If yes is chosen, enter code 1111. If NO is chosen the system returns to cook mode for 15 minutes then redisplay error until issue is fixed.

1.11.4 Error Log Codes

Code	ERROR MESSAGE	EXPLANATION
E03	ERROR TEMP PROBE FAILURE	TEMP Probe reading out of range
E04	HI 2 BAD	High limit reading is out of range.
E05	HOT HI 1	High limit temperature is past more than 410°F (210°C), or in CE countries, 395°F (202°C)
E06	HEATING FAILURE	A component has failed in the high limit circuit such as controller, interface board, contactor or open-high limit.
E20	INVALID CODE LOCATION	SD card removed during update
E21	FILTER PAPER PROCEDURE ERROR (Change Filter Paper)	25-hour or customer-set timer has expired.
E22	OIL IN PAN ERROR	Oil may be present in the filter pan.
E25	RECOVERY FAULT	Recovery time exceeded maximum time limit. Recovery time should not exceed 1:40 for electric.
E27	LOW TEMP ALARM	Oil temperature has dropped 30°F (17°C) lower than setpoint in idle mode or 45°F (25°C) in cook mode. (This message may appear if a product is dropped and the start cook button is not pressed immediately or if too large of cook loads are dropped.)

1.11.5 Tech Mode

Tech mode allows technicians to reset all passwords set in levels one and two and change when the fryer calls for a filter pad change. The default is 25 hours.

1. Press and hold ◀ and ▶ simultaneously for **TEN** seconds until three chirps sound and **TECH MODE** is displayed.
2. Enter **1650**.
3. The computer displays **CLEAR PASSWORDS**.
4. Press the ✓ (1) button to accept selection and clear the passwords.
5. The computer displays **CLEAR PASSWORDS** on the left and **COMPLETE** on the right. This clears any passwords set up under levels one and two.
6. Press the ▼ button to toggle to **FILTER PAD TIME** on the left and **DISABLED** on the right.
7. Press the ✕ (2) button to accept changes and exit.
8. The computer displays **OFF**.

1.11.6 M3000 Menu Summary Tree

Reflected below are the major programming sections in the M3000 and the order in which submenu headings will be found under the sections in the M3000 Manual LOV Controller Manual (819-6964).

Adding New Product Menu Items Controller Manual

See section 2.10.2 in the

Filter Menu	2.11
[Press and hold ◀ FLTR or FLTR ▶]	
Quick Filter	
Maint Filter	
Dispose	
Drain to Pan	
Fill Vat from Drain Pan	
 Programming	
Level 1 Program	2.12
[Press and hold TEMP and INFO buttons, 2 beeps, displays Level 1, enter 1234]	
Product Selection	2.10.2
Name	
Cook Time	
Temp	
Cook ID	
Duty Time 1	
Duty Time 2	
Qual Tmr	
AIF Disable	
Assign Btn	
AIF Clock (Suppress Filter Prompt)	2.12.1
Disabled	
Enabled	
Deep Clean Mode	2.12.2
High-Limit Test	2.12.3
Fryer Setup	2.9
 Level 2 Program (Manager Level)	2.13
[Press and hold TEMP and INFO buttons, 3 beeps, displays Level 2, enter 1234]	
Prod Comp Sensitivity for product	2.13.1
E-Log Log of last 10 error codes	2.13.2
Password Setup Change passwords	2.13.3
Setup [enter 1234]	
Usage [enter 4321]	
Level 1 [enter 1234]	
Level 2 [enter 1234]	
Alert Tone Volume and Tone	2.13.4
Volume 1-9	
Tone 1-3	
Top Off After Sets number of cooks before top off prompt	2.13.5
Filter After Sets number of cooks before filter prompt	2.13.6
Filter Time Sets amount of time between filter cycles	2.13.7
 Info Mode	2.14
[Press and hold INFO for 3 seconds, displays Info Mode]	
Full/Split Vat Configuration	
Filter Stats	2.14.1
Review Usage	2.14.2
Last Load	2.14.3

1.11.7 M3000 Controller Pin Positions and Harnesses

Connector	From/To	Harness PN	Pin #	Function	Voltage	Wire Color		
J2	Interface Board to Controller	8074199 SMT Controller to Interface Board Harness	1	12VAC In	12VAC	Black		
			2	Ground				
			3	12VAC In	12VAC			
			4	FV Heat Demand				
			5	V Relay	12VDC			
			6	DV Heat Demand				
			7	R/H B/L	12VDC			
			8	Analog Ground				
			9	L/H B/L	12VDC			
			10	ALARM				
			11	Sound Device	5VDC			
			12	ALARM				
			13	FV Probe				
			14	Common Probes				
			15	DV Probe				
			16					
			17					
			18					
			19					
			20					
J3	Locator Harness Interface Board Ground to Controller	1080485	1	Vat #1		Black		
		1080486	2	Vat #2				
		1080487	3	Vat #3				
		1080488	4	Vat #4				
		1080489	5	Vat #5				
			6					
J4	Drain Switch	8075159 (FV) 8075160 (DV)	1	FV Drain		Black		
			2	FV Drain		Red		
			3	DV Drain		Black		
			4	DV Drain		Red		
J6	Previous M3000 J7 or Network Resistor	8074546 Controller Communication Harness	1	Ground		Black		
			2	CAN Lo		Red		
			3	CAN Hi		White		
			4					
			5					
			6					
J7	Next M3000 J6	8074646 Controller Communication Harness	1	Ground		Black		
			2	CAN Lo		Red		
			3	CAN Hi		White		
			4					
			5					
			6					

1.12 Loading and Updating Software Procedures

Updating the software takes approximately 30 minutes. The software only needs to be loaded in **Left** controller and it will update **all** the controllers in the system. Press the TEMP button to check current M3000 software version. Remove the bezel by removing the screws under the bottom of the bezel. Remove the two screws securing the controller allow it to swing down. Remove the two screws on the left side cover plate of the far left M3000 controller.

To update the software, follow these steps carefully:

Left Display	Right Display	Action
OFF	OFF	With the controller folded down, insert the SD card, with the contacts facing down and the notch on the bottom right (see Figure 8 and 9), into the slot on the left side of the M3000 controller. ENSURE THE CARD IS FULLY INSERTED INTO THE SD CARD SLOT.
UPGRADE IN PROGRESS	WAIT	None required.
CC UPDATING	PERCENTAGE COMPLETE changing to BOOT	None required. . <u>DO NOT REMOVE THE CARD UNTIL THE DISPLAY PROMPTS TO DO SO.</u>
UPGRADE IN PROGRESS	WAIT	None required.
COOK HEX	PERCENTAGE COMPLETE	None required.
REMOVE SD CARD	100	Remove the SD card using the fingernail slot on the top of the SD card.
CYCLE POWER.	BLANK	Cycle the control power using the reset switch behind the far right control box. ENSURE THE SWITCH IS HELD FOR 10 SECONDS. WAIT ANOTHER 20 SECONDS AFTER THE RESET BEFORE CONTINUING.
OFF	BOOT	The left controller displays OFF . The remaining controllers display a flashing BOOT while the program is transferred.
OFF	OFF	With the controller displaying OFF, VERIFY software update by pressing the TEMP button to check updated M3000 version on each controller. IF <u>ANY BOARDS DID NOT UPDATE, REPEAT THE PROCESS BY INSERTING THE SD CARD AGAIN.</u>
OFF	OFF	Once the software has been updated and the versions are correct, replace the cover and screws covering the SD card slot. Replace the screws attaching the controller and replace the bezel and screws.



Figure 8



Figure 9

1.13 Interface Board Diagnostic Chart

The following diagram and charts provide ten quick system checks that can be performed using only a multimeter.

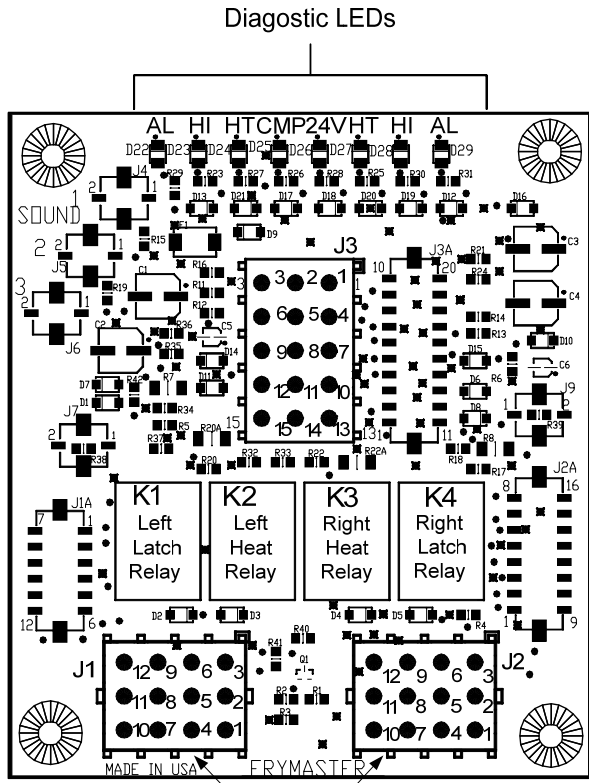

Diagnostic LED Legend	
CMP	indicates power from 12V transformer
24	indicates power from 24V transformer
HI	(RH) indicates output (closed) from right latch relay
HI	(LH) indicates output (closed) from left latch relay
HT	(RH) indicates output (closed) from right heat relay
HT	(LH) indicates output from left heat relay
AL	(RH) indicates output (open) from right latch relay
AL	(LH) indicates output (open) from left latch relay

PN 826-2260 (106-6664)

Test Points
J1 Left J2 Right

NOTE – Pin 1 is located in the bottom right corner of Both J1 and J2. These test points are **ONLY** for the BIEL14 Series boards with J1 and J2 plugs on the front of the board.

Meter Setting	Test	Pin	Pin	Results
12 VAC Power	50 VAC Scale	3 of J2	1 of J2	12-16 VAC
24 VAC Power	50 VAC Scale	2 of J2	Chassis	24-30 VAC
*Probe Resistance (RH)	R X 1000 OHMS	11 of J2	10 of J2	See Chart
*Probe Resistance (LH)	R X 1000 OHMS	1 of J1	2 of J1	See Chart
High-Limit Continuity (RH)	R X 1 OHMS	9 of J2	6 of J2	0 - OHMS
High-Limit Continuity (LH)	R X 1 OHMS	6 of J1	9 of J1	0 - OHMS
Latch Contactor Coil (RH)	R X 1 OHMS	8 of J2	Chassis	3-10 OHMS
Latch Contactor Coil (LH)	R X 1 OHMS	5 of J1	Chassis	3-10 OHMS
Heat Contactor Coil (RH)	R X 1 OHMS	7 of J2	Chassis	11-15 OHMS
Heat Contactor Coil (LH)	R X 1 OHMS	4 of J1	Chassis	11-15 OHMS

* Disconnect 15-Pin harness from the controller/controller before testing the probe circuit.

1.14 Probe Resistance Chart

<h3 style="text-align: center;">Probe Resistance Chart</h3> <p style="text-align: center;"><i>For use with fryers manufactured with Minco Thermistor probes only.</i></p>																	
F	OHMS	C	F	OHMS	C	F	OHMS	C	F	OHMS	C	F	OHMS	C			
60	1059	16	130	1204	54	200	1350	93	270	1493	132	340	1634	171			
65	1070	18	135	1216	57	205	1361	96	275	1503	135	345	1644	174			
70	1080	21	140	1226	60	210	1371	99	280	1514	138	350	1654	177			
75	1091	24	145	1237	63	215	1381	102	285	1524	141	355	1664	179			
80	1101	27	150	1247	66	220	1391	104	290	1534	143	360	1674	182			
85	1112	29	155	1258	68	225	1402	107	295	1544	146	365	1684	185			
90	1122	32	160	1268	71	230	1412	110	300	1554	149	370	1694	188			
95	1133	35	165	1278	74	235	1422	113	305	1564	152	375	1704	191			
100	1143	38	170	1289	77	240	1432	116	310	1574	154	380	1714	193			
105	1154	41	175	1299	79	245	1442	118	315	1584	157	385	1724	196			
110	1164	43	180	1309	82	250	1453	121	320	1594	160	390	1734	199			
115	1174	46	185	1320	85	255	1463	124	325	1604	163	395	1744	202			
120	1185	49	190	1330	88	260	1473	127	330	1614	166	400	1754	204			
125	1195	52	195	1340	91	265	1483	129	335	1624	168	405	1764	207			

1.15 Wiring Diagrams

1.15.1 Manual LOV Electric Series Simplified Wiring

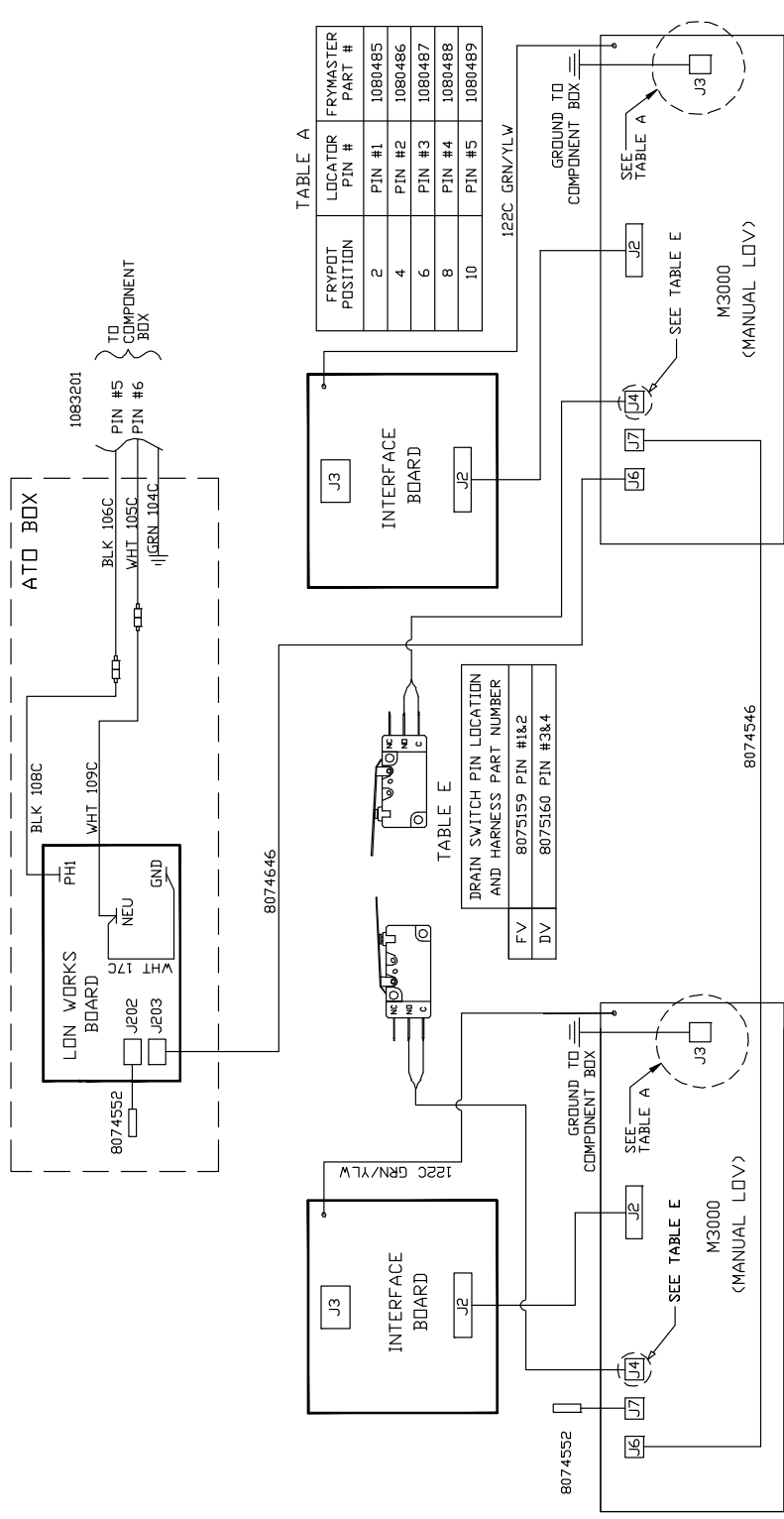

TABLE A

FRYPOT POSITION	LOCATOR PIN #	FRYMASTER PART #
2	PIN #1	1080485
4	PIN #2	1080486
6	PIN #3	1080487
8	PIN #4	1080488
10	PIN #5	1080489

TABLE E

DRAIN SWITCH PIN LOCATION AND HARNESS PART NUMBER
FV 8075159 PIN #1&2
DV 8075160 PIN #3&4

8051943B

1.15.2 Control Wiring with Manual LOV M3000 Controller

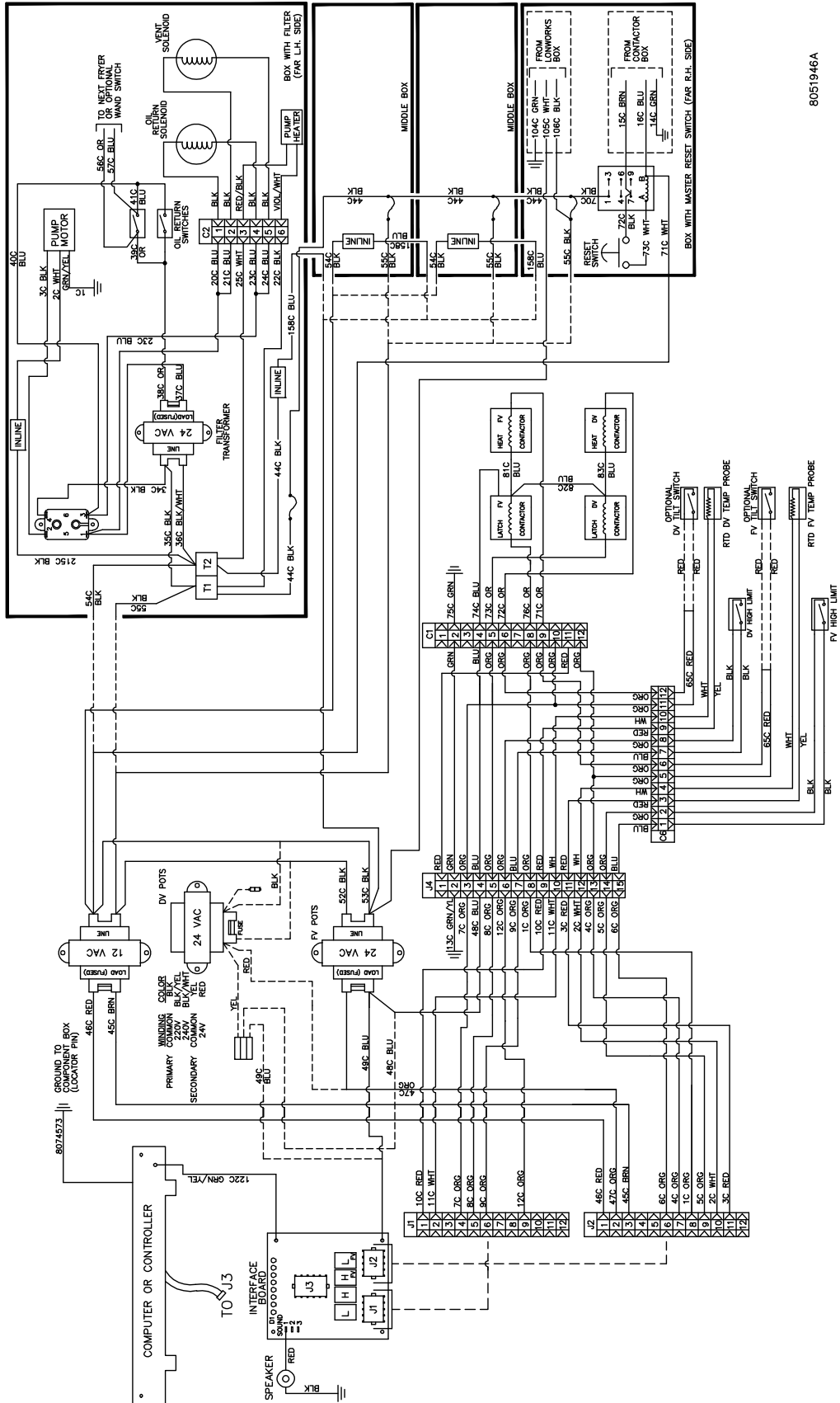

8051946A

1.15.3 Contactor Box – Delta Configuration

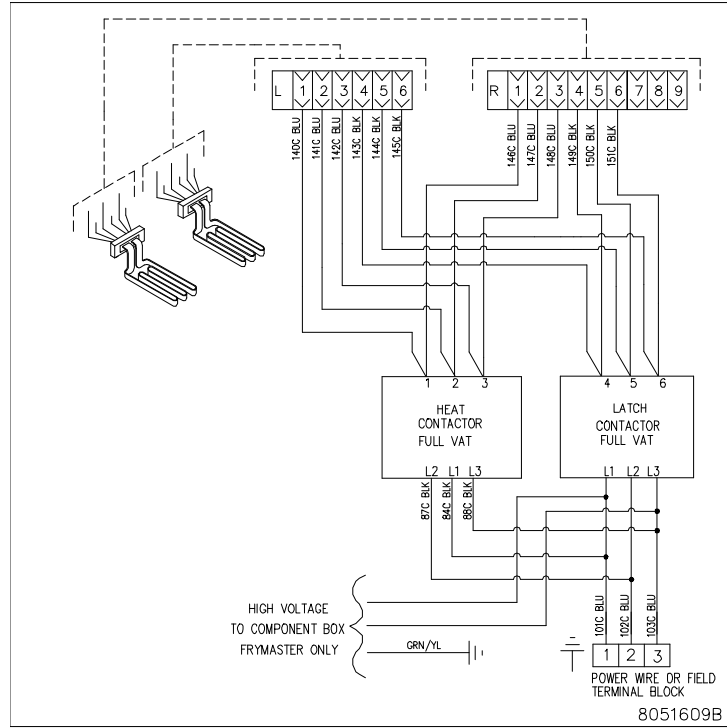

FULL VAT

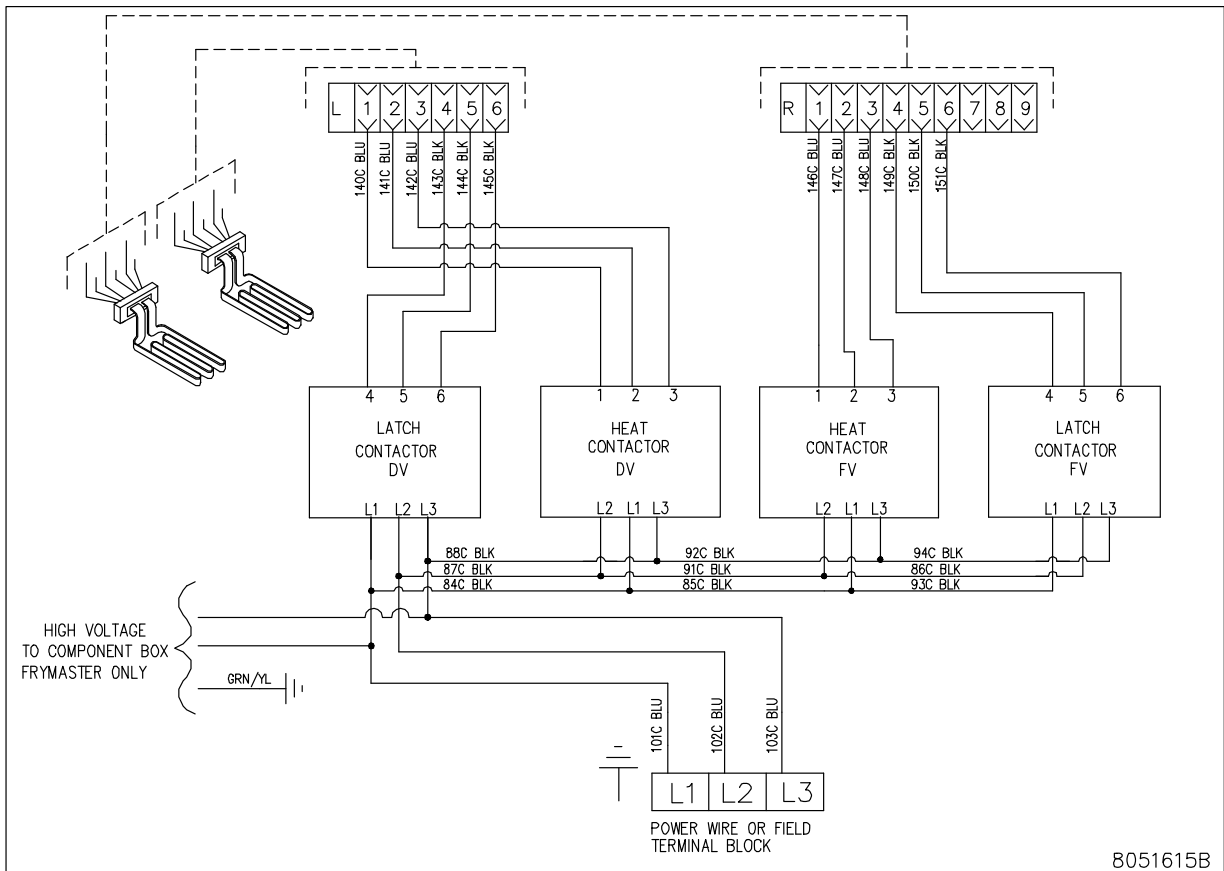

DUAL VAT

1.15.4 Contactor Box – WYE Configuration

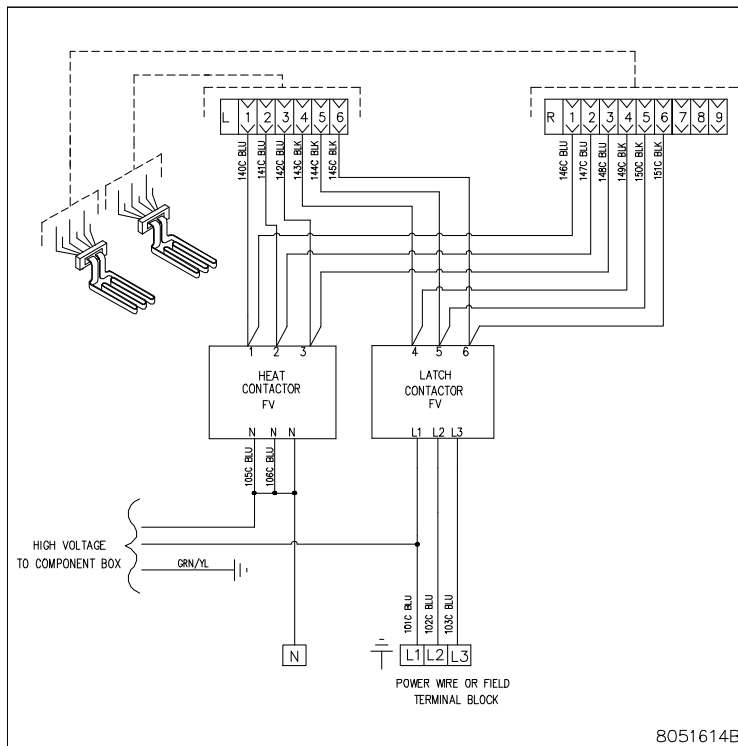

FULL VAT

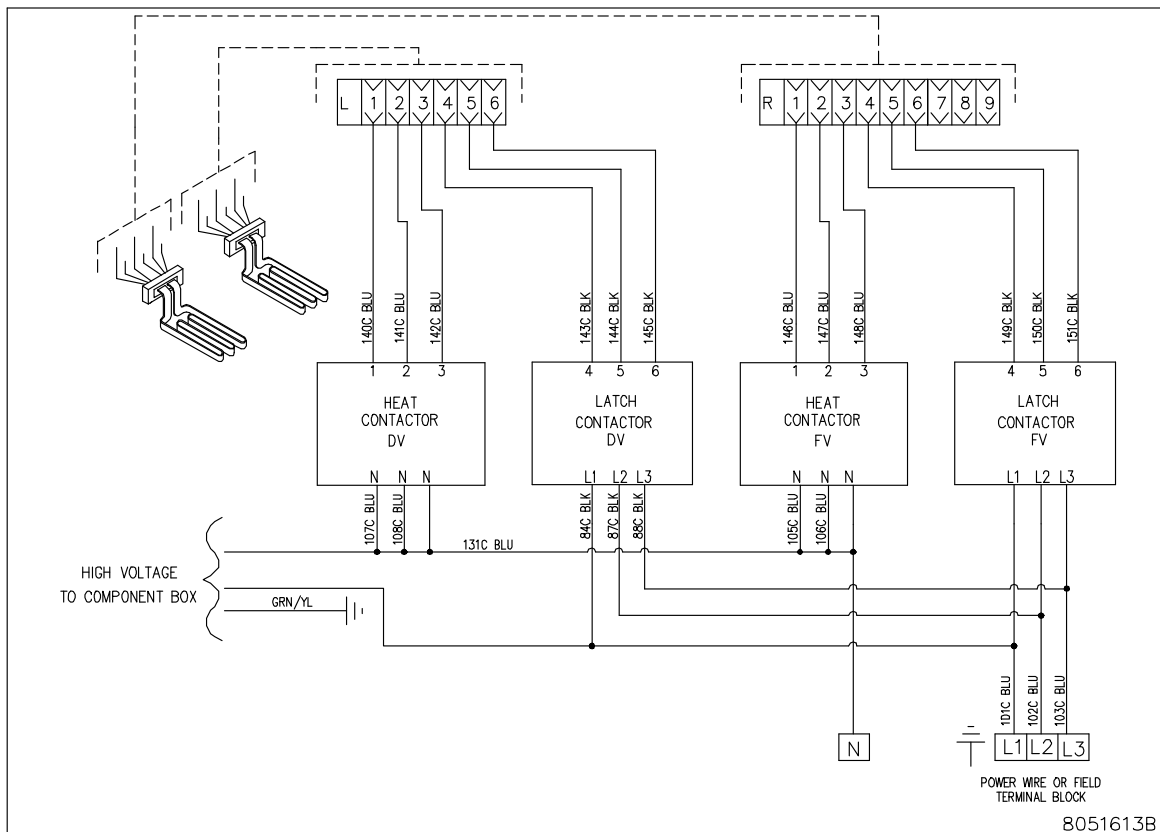

DUAL VAT

1.15.5 Simplified BIEL14 Manual LOV Series – Full Vat Delta Wiring

ELECTRIC BIEL14 MANUAL LOV™ SERIES - FULL-VAT

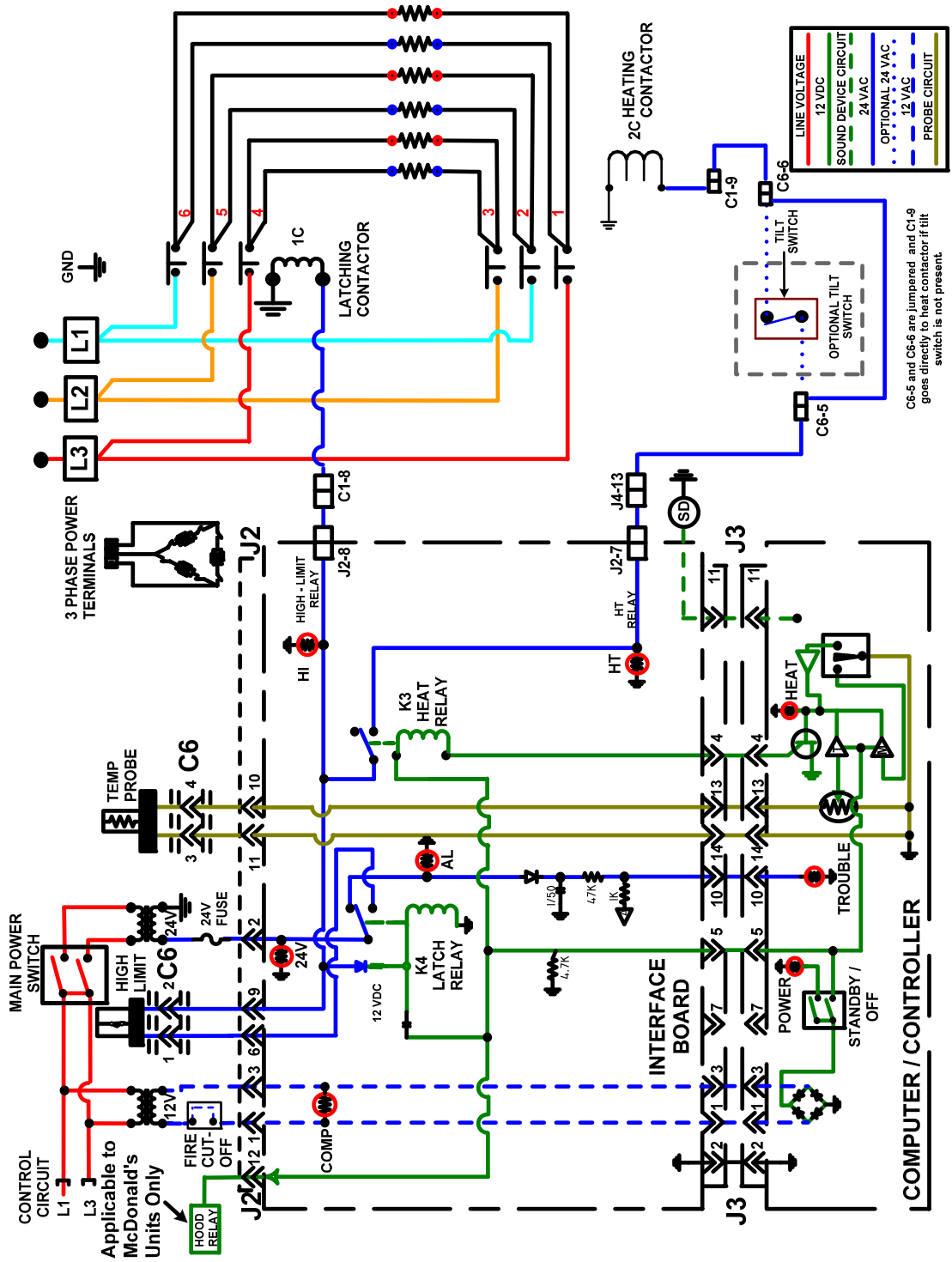

1.15.6 Simplified BIEL14 Manual LOV Series – Dual Vat Delta Wiring

ELECTRIC BIEL14 MANUAL LOV™ SERIES - DUAL-VAT

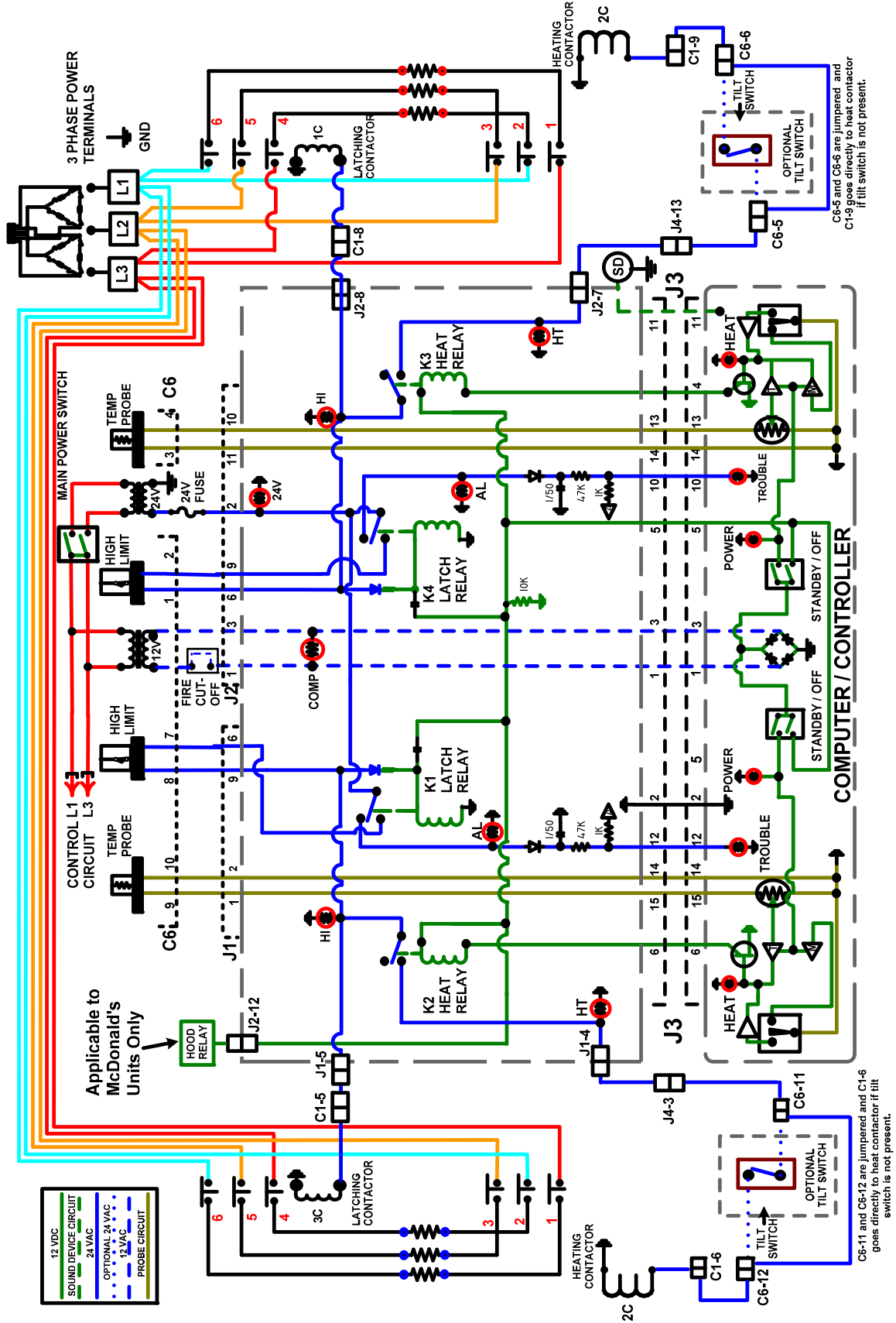

1.15.7 Simplified BIEL14 Manual LOV Series – Full Vat Wiring EXPORT WYE

ELECTRIC BIEL14 MANUAL LOV™ SERIES - FULL-VAT EXPORT WYE

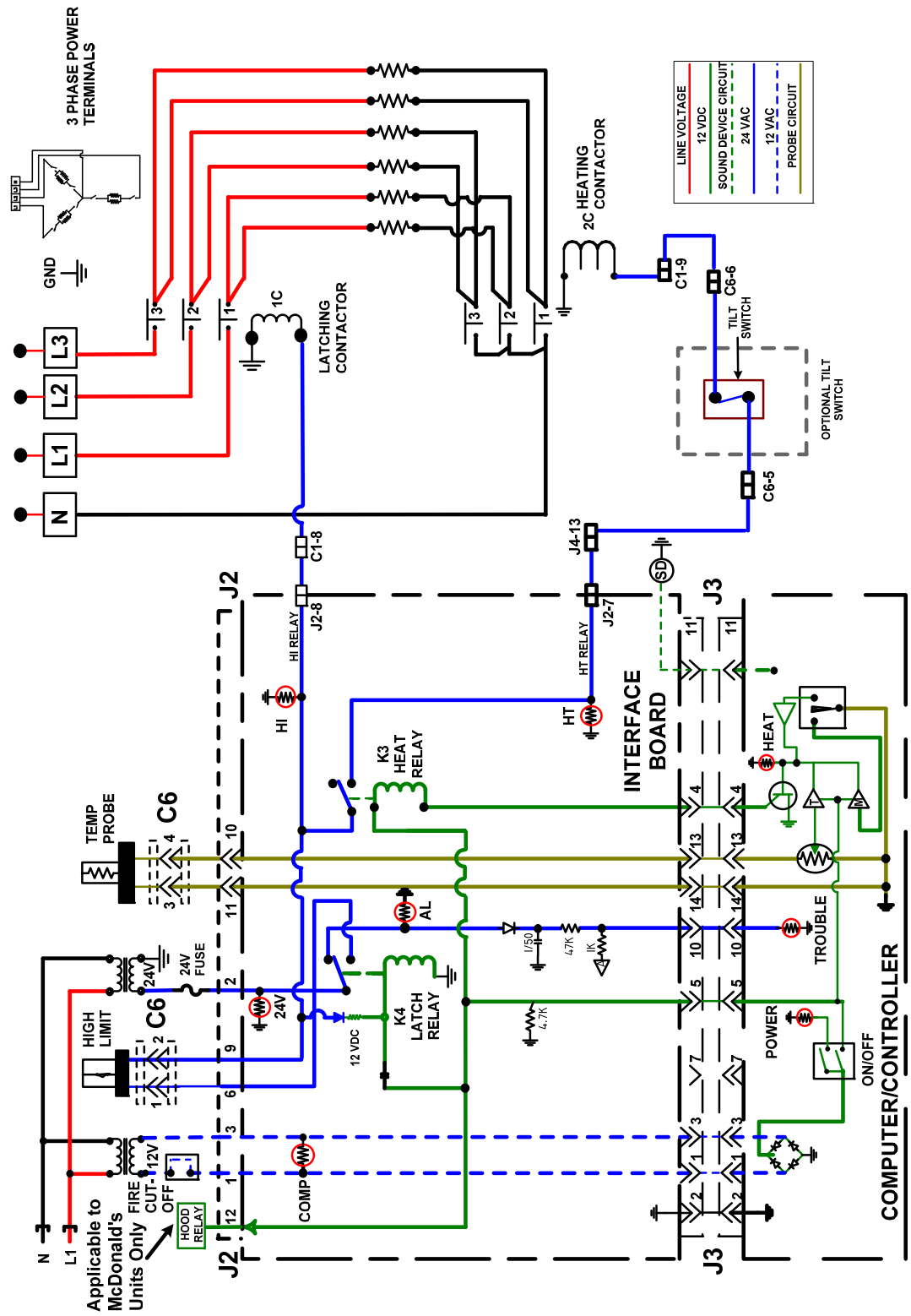

1.15.8 Simplified BIEL14 Manual LOV Series – Dual Vat Wiring EXPORT WYE

ELECTRIC BIEL14 MANUAL LOV™ SERIES - DUAL-VAT EXPORT WYE

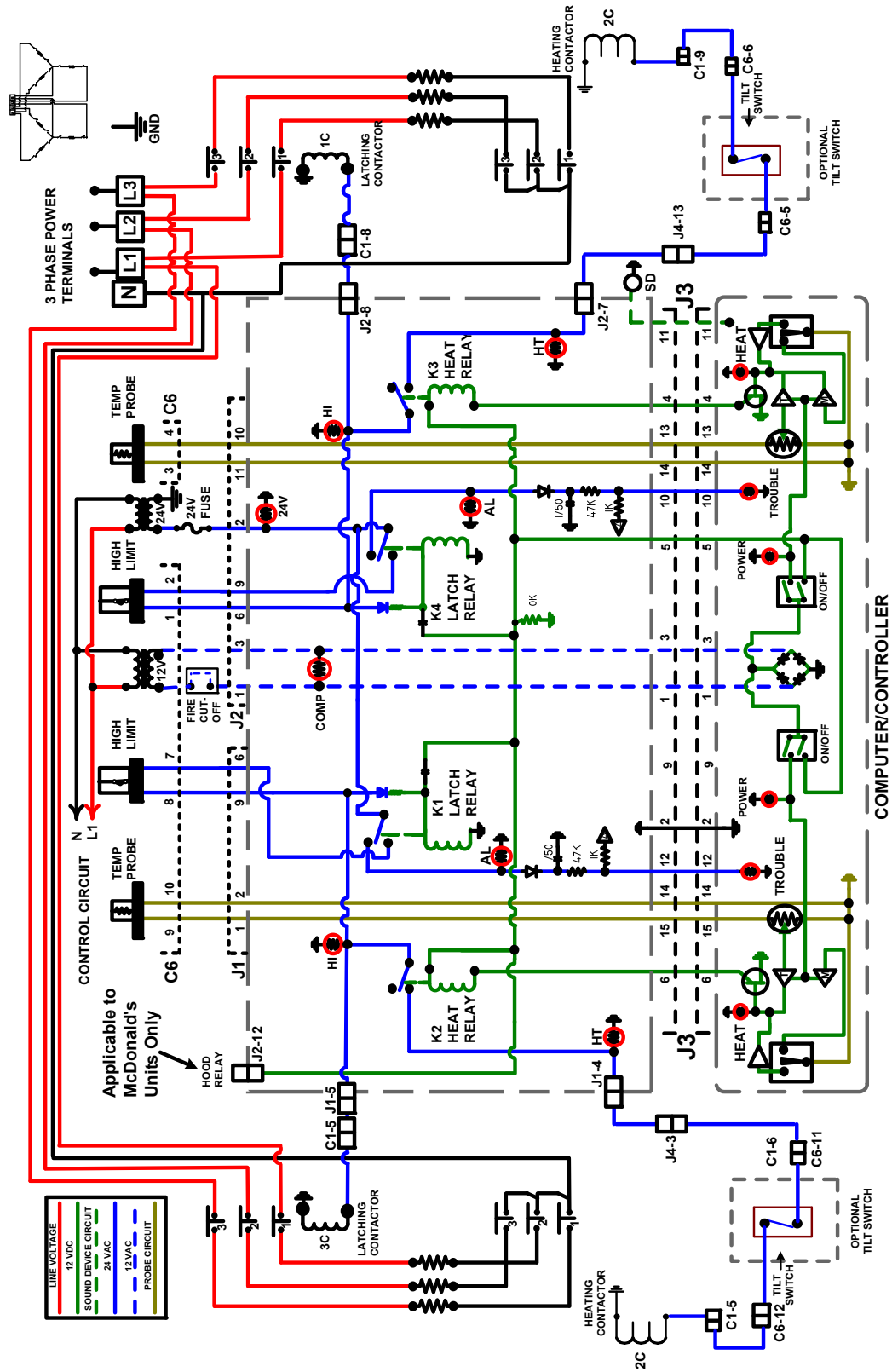

1.15.9 BIEL14 Series Data Network Flowchart

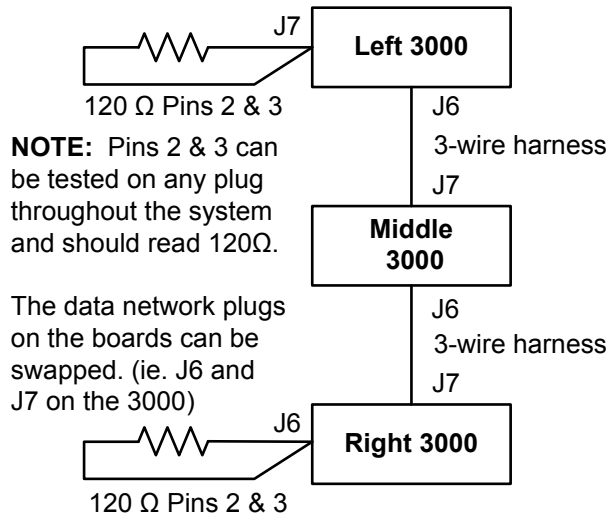

Harness	Pin #	Function	Voltage	Wire Color
3-wire harness	1	Ground		Black
	2	CAN Lo		Red
	3	CAN Hi		White
	4	NOT USED		
	5			
	6			

Turn each computer to OFF. Press the TEMP button on each computer and verify ALL software versions are present and match.

MANUAL LOV™ SERIES ELECTRIC FRYERS

CHAPTER 2: PARTS LIST

2.1 Accessories

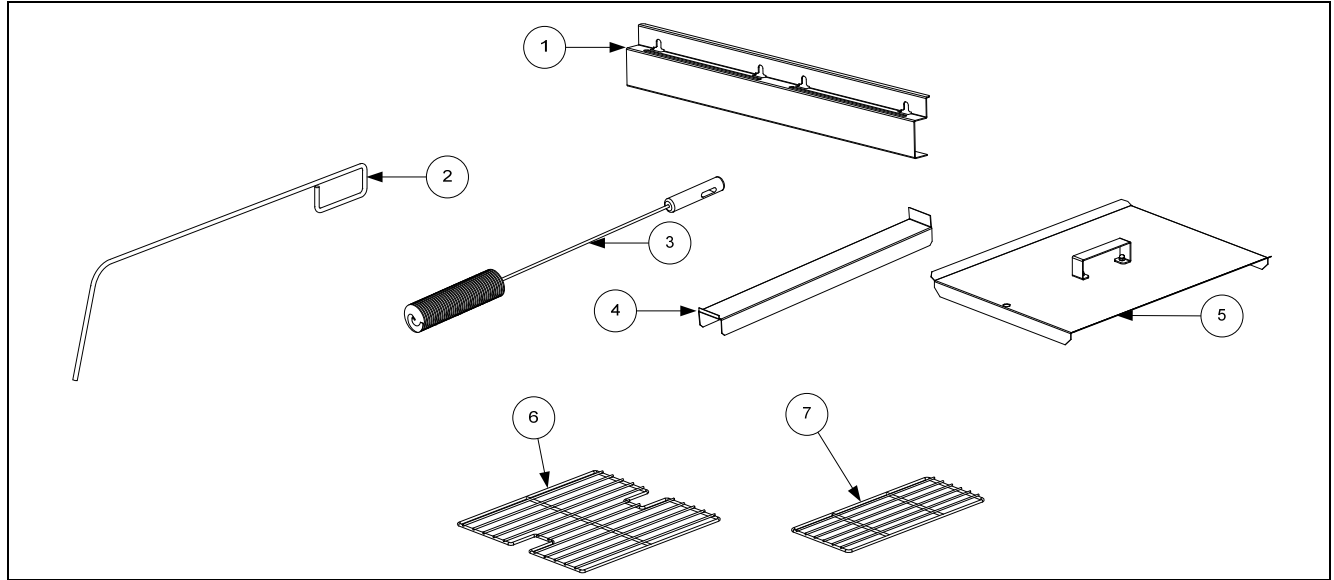

ITEM	PART #	COMPONENT
1	230-7495	Hanger, Basket Two Station
	230-7497	Hanger, Basket Three Station
	230-7495 (2)	Hanger, Basket Four Station
	230-7497, 230-7495	Hanger, Basket Five Station
2	803-0197	Cleanout Rod, 27-inch
3	803-0398	Brush, Frypot
4	823-7263	Connecting Strip, Frypot
5	106-8325	Cover, Full-Vat Frypot
	106-8329	Cover, Dual-Vat Frypot
6	803-0132	Rack, Full-Vat Basket Support
7	803-0136	Rack, Dual-Vat Basket Support

*Not illustrated.

2.2 Doors, Sides, Tilt Housings, Top Caps and Casters

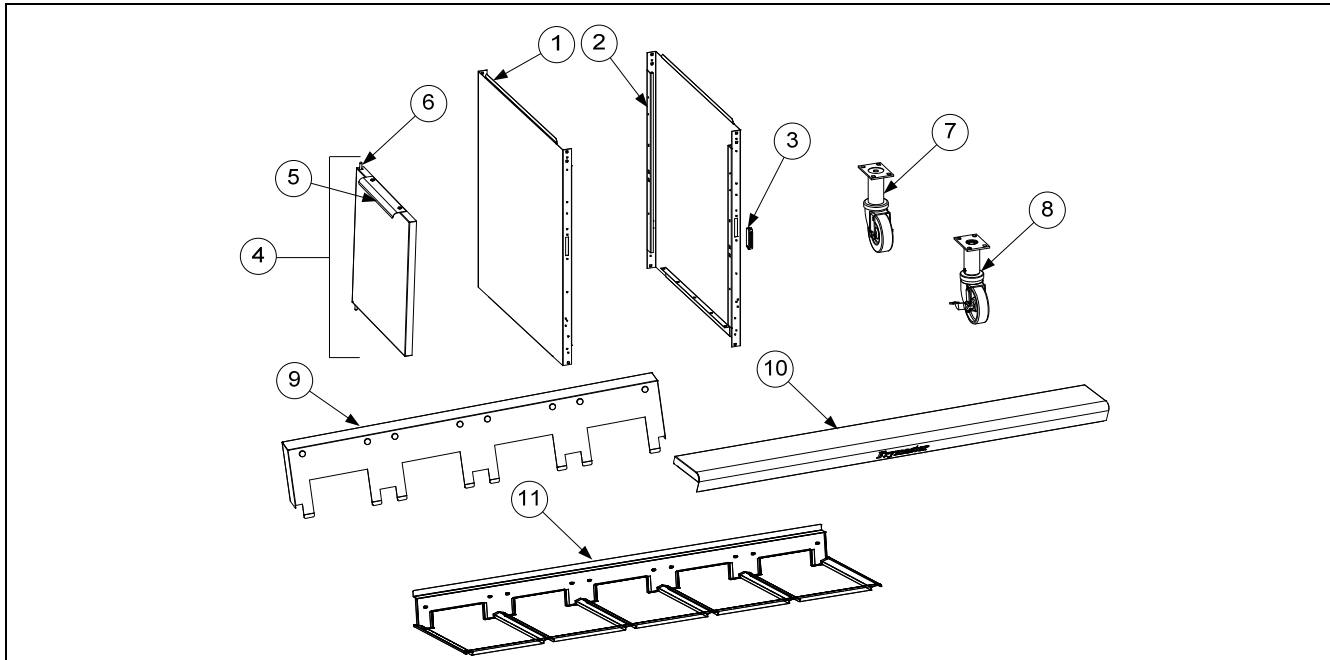

ITEM	PART #	COMPONENT
1	231-0323	Side, Standard Cabinet Left SS (use 221-0323 for Enameled Steel)
2	232-0323	Side, Standard Cabinet Right SS (use 222-0323 for Enameled Steel)
3	810-1105	Magnet, Door (vertical) (use 810-2346 for horizontal over filter pan)
4	106-4397	Door, Left or Right (Left shown – move handle to bottom for right)
5	230-4960	Handle, Door
6	106-4067	Pin Assembly, Door
*	810-0275	Spring, Door Pin
*	809-0970	Retaining Ring
*	230-7192	Hinge, Door Lower
*	210-8288	Panel, Universal Door
*	220-6097	Holder, Manual
7	810-0327	Caster adjustable 4" without Brake
8	810-0944	Caster adjustable 3" with Brake
9		Tilt Housing (Housing for four station fryer shown)
	823-7891	Two Station, S/S (<i>use 108-0131 for Aluminized Steel</i>) (910-2441 Hoodstrip)
	823-7892	Three Station, S/S (<i>use 108-0132 for Aluminized Steel</i>) (910-2440 Hoodstrip)
	823-7893	Four Station, S/S (<i>use 108-0133 for Aluminized Steel</i>) (910-2439 Hoodstrip)
	823-6243	Five Station, S/S (<i>use 108-0138 for Aluminized Steel</i>) (910-9447 Hoodstrip)
10		Top Cap (Top cap for five station fryer shown)
	106-7835	Two Station (<i>Also requires four 809-0078 10-32 Nutserts</i>)
	106-5979	Three Station (<i>Also requires six 809-0078 10-32 Nutserts</i>)
	106-7576	Four Station (<i>Also requires eight 809-0078 10-32 Nutserts</i>)
	106-7841	Five Station (<i>Also requires ten 809-0078 10-32 Nutserts</i>)
11		Cap-N-Splash
	823-6420	Two Station
	823-6421	Three Station
	823-6422	Four Station
	823-6887	Five Station

* Not illustrated.

2.3 Drain System Components

2.3.1 Drain Tube Sections and Associated Parts

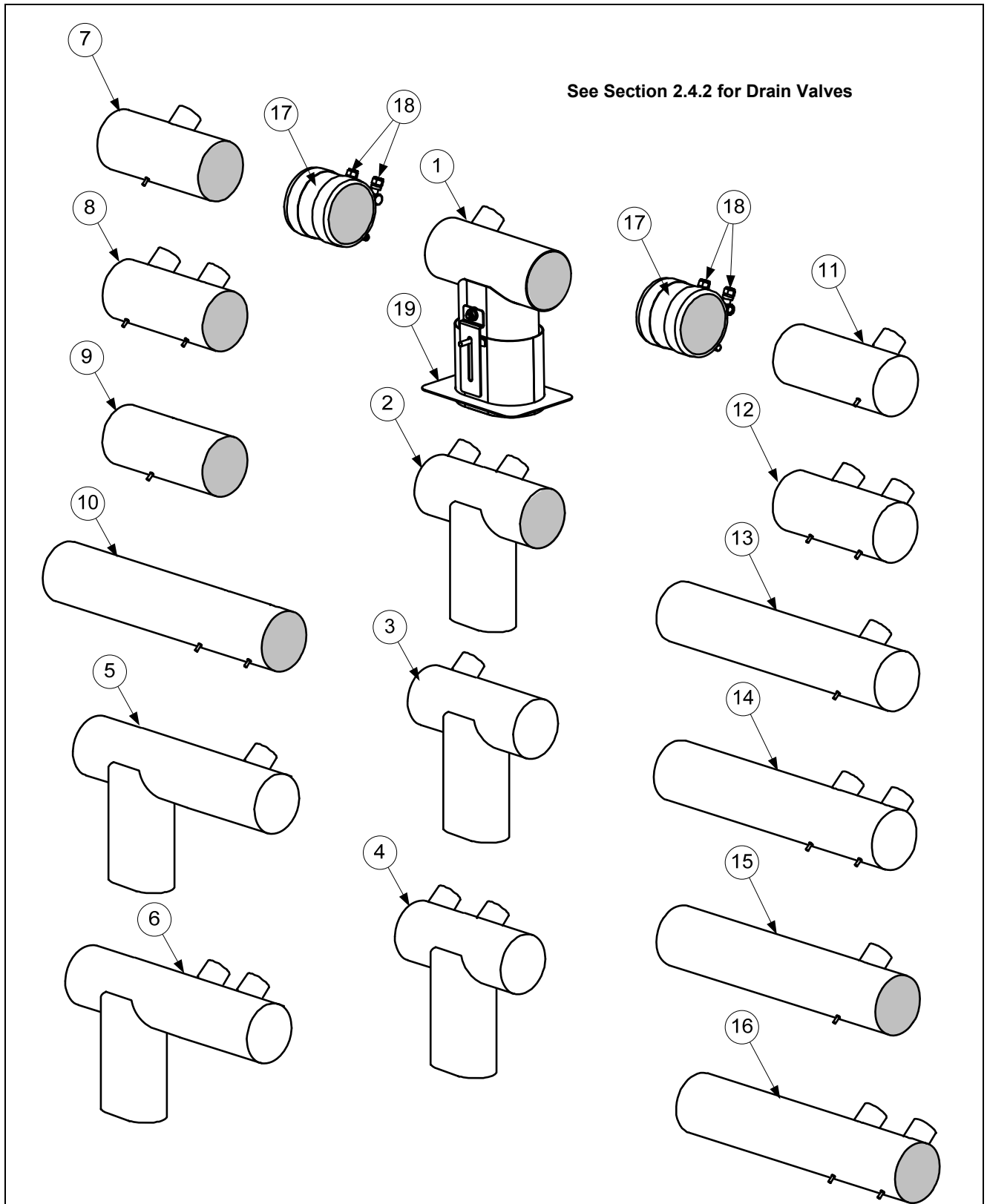

2.3.1 Drain Tube Sections and Associated Parts cont.

ITEM	PART#	COMPONENT
1	823-8141	Drain Tube, Dump Full-Vat Left Closed/Right End Open
2	823-8142	Drain Tube, Dump Dual-Vat Left Closed/Right End Open
3	823-8143	Drain Tube, Dump Full-Vat Left Closed Both Ends
	823-7939	Drain Tube, Dump Single Full-Vat Left Closed Both Ends
4	823-8144	Drain Tube, Dump Dual-Vat Left Closed Both Ends
	823-7936	Drain Tube, Dump Single Dual-Vat Left Closed Both Ends
5	823-8145	Drain Tube, Dump Full-Vat Left Closed Both Ends
*	823-8128	Drain Tube, Dump Full-Vat Left Closed/Right End Open
6	823-8146	Drain Tube, Dump Dual-Vat Left Closed Both Ends
*	823-8129	Drain Tube, Dump Dual-Vat Left Closed/Right End Open
7	823-4643	Drain Tube, Full-Vat, Short, Open Both Ends
8	823-7905	Drain Tube, Dual-Vat, Short, Open Both Ends
9	810-3550	Drain Tube, Short, Open Both Ends
10	810-3551	Drain Tube, Long, Open Both Ends
11	823-4625	Drain Tube, Short Full-Vat Left Open/Right End Closed
12	823-7906	Drain Tube, Short Dual-Vat Left Open/Right End Closed
13	823-4639	Drain Tube, Long Full-Vat Left Open/Right End Closed
14	823-7908	Drain Tube, Long Dual-Vat Left Open/Right End Closed
15	823-4641	Drain Tube, Long Full-Vat Open Both Ends
16	823-7907	Drain Tube, Long Dual-Vat Open Both Ends
17	816-0772	Sleeve
18	809-0969	Clamp
*	816-0630	Vinyl Cap
*	811-1071	Tubing, 1/4-inch OD Teflon Vent (sold by the foot)
19	823-7915	Guard, Filter Lid Splash

* Not illustrated.

2.3.2 Drain Valve Assembly

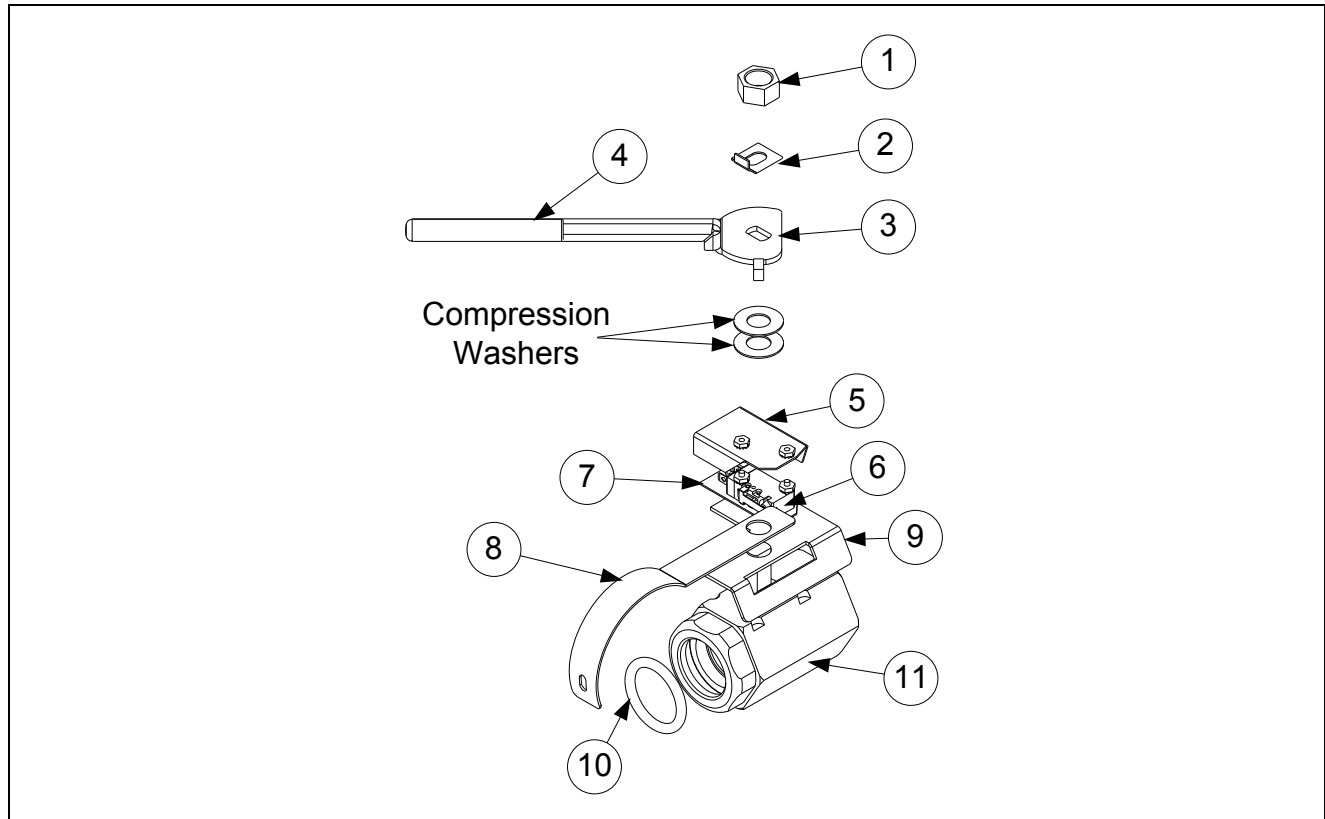

ITEM	PART #	COMPONENT
	108-2451	Valve, Assembly Drain FV
	108-2452	Valve, Assembly Drain DV
1	809-0540	Nut, 1/2-13 2-Way Hex Lock
2	900-2936	Retainer, Nut Drain Valve
3	824-2188	Handle, Drain Valve FV
	824-2189	Handle, Drain Valve DV
4	816-0639	Cap, Vinyl Red
5	901-2348	Cover, Safety Switch
6	807-4936	Switch, Micro Gold Plated
7	816-0220	Insulation, RF Switch
8	200-6496	Support, Drain Tube
	220-8162	Bracket, Single 1/4-inch Drain Valve
9	108-2453	Bracket Assy, Drain Switch
10	816-0135	O-Ring, Round Drain Seal
11	810-1018	Valve, 1/4-inch Drain
*	807-5159	Harness, Drain FV (<i>connects from drain switch to rear of controller</i>)
*	807-5160	Harness, Drain DV (<i>connects from drain switch to rear of controller</i>)

2.4 Electronics and Wiring Components

2.4.1 Component Boxes

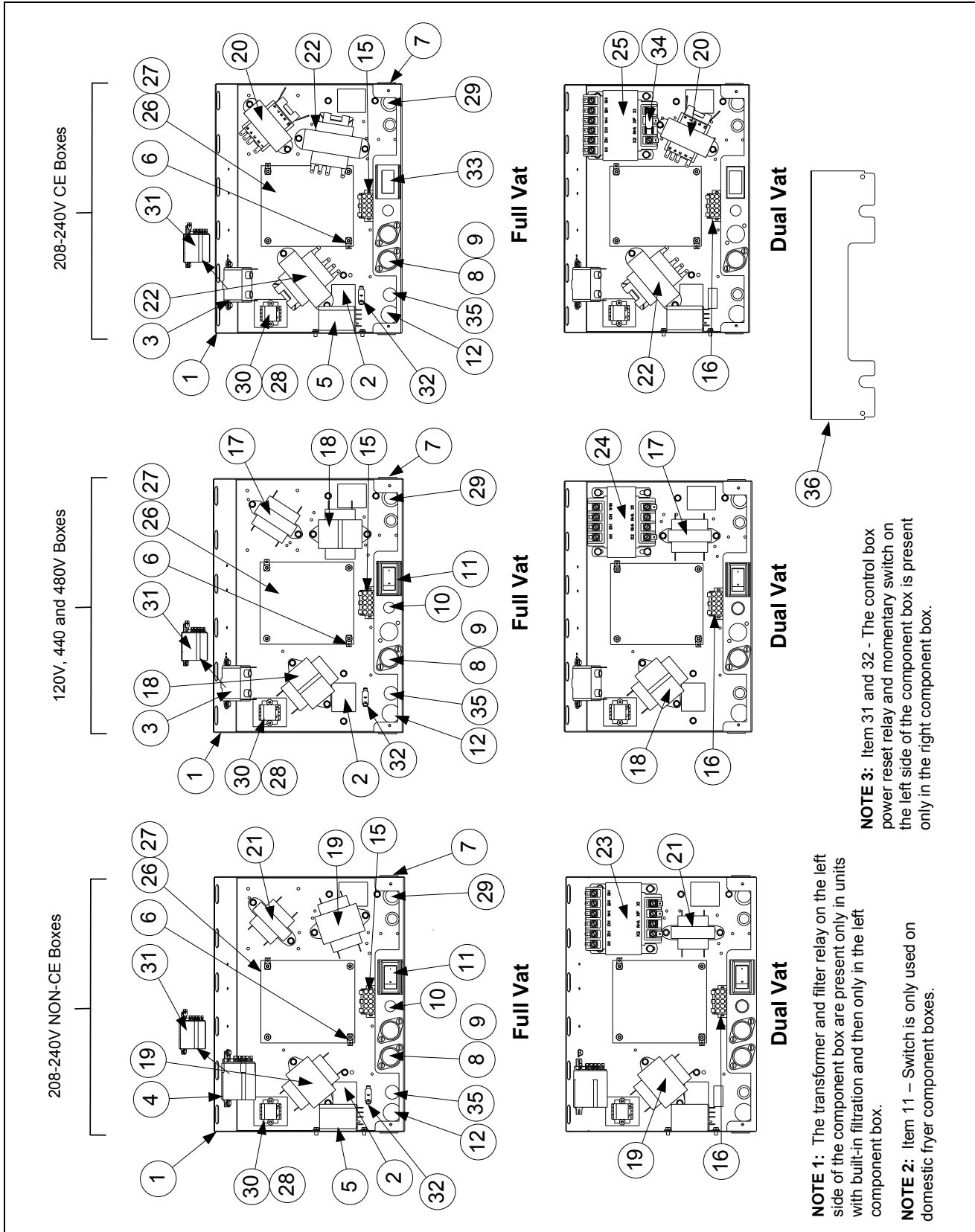

2.4.1 Component Boxes cont.

ITEM	PART #	COMPONENT
1	106-5592	Box Assembly, Component
2	200-3300	Bracket, Component Box Strain Relief
√ 3	807-0012	Relay, Filter 18A, 1/3HP 24VAC
√ 4	807-0670	Relay, Filter DPDT 20A 24VAC
√ 5	807-4770	Relay, 240V DPDT 20A
√	807-4346	Relay, 120V DPDT 20A <i>(used in Canadian models only)</i>
6	807-0037	Terminal, ¼-inch Push-on
7	807-0121	Bushing, Heyco Plastic AB-625-500
8	807-0922	Holder, Buss Fuse HPS Screw Type
√ 9	807-2278	Fuse, 20 Amp
10	810-2446	Plug, Button .50 Heyco Double "D"
√ 11	807-4036	Switch, Power
	807-3575	Plug, Carling Switch Hole <i>(used on some models without a switch)</i>
12	807-1947	Plug, Button .875 Dome
13	807-1321	Holder, AGC Panel Mount ¼" Fuse <i>(Some models use item 10 here.)</i>
14	807-1597	Fuse, 3 AMP Slow-Blow
15	106-5750	Harness Assembly, RE FV Control
16	106-5751	Harness Assembly, RE DV Control
√ 17	807-0855	Transformer, 100-120V 12V 20VA
√ 18	807-0800	Transformer, 100-120V 24V 50VA Filter
√ 19	807-0680	Transformer, 208-240V 24V 20VA Filter
√ 20	807-2191	Transformer, 208-240V 12V 30VA
√ 21	807-0979	Transformer, 208-240V 12V 43VA
√ 22	807-2180	Transformer, 100-120V 50VA Filter
√ 23	812-2126	Transformer, 208-250V 24V 75VA w/o Fuse <i>(Used in DV component boxes)</i>
√ 24	807-4967	Transformer, 100-120V 24V 75VA <i>(Used in DV component boxes)</i>
√ 25	807-4968	Transformer, 208-250V 24V 75VA <i>(Used in DV component boxes)</i>
√ 26	826-2260	Interface Board Standard Full or Dual Vat <i>(includes sound harness)</i>
*	807-4403	Speaker, 4-Watt SMT
27	809-0349	Spacer, 4mm X 6mm Aluminum
28	816-0217	Paper, Insulating Terminal Block
29	810-0045	Bushing, .875 Diameter 11/16"
30	806-9495SP	Terminal Block
√ 31	807-4346	Relay, DPDT 20A 120V <i>(used for control power reset in right hand boxes only in domestic and Canadian units)</i>
√	807-4770	Relay, DPDT 20A 240V <i>(used for control power reset in right hand boxes only in international units; some international units have one located in each control box)</i>
32	807-2659	Switch, Momentary <i>(used to reset control power, in right hand boxes only)</i>
33	230-5038	Guard, Switch
√ 34	807-1174	Fuse, 250V 3 AMP Slow-Blow
35	810-2445	Plug, Button .625 Heyco Double "D"
36	220-5038	Guard Finger
*	826-2249	RE Hood/Ansul Interlock Kit (includes terminal block, wires and connectors)

* Not illustrated.

√ Recommended parts.

2.4.2 Contactor Boxes

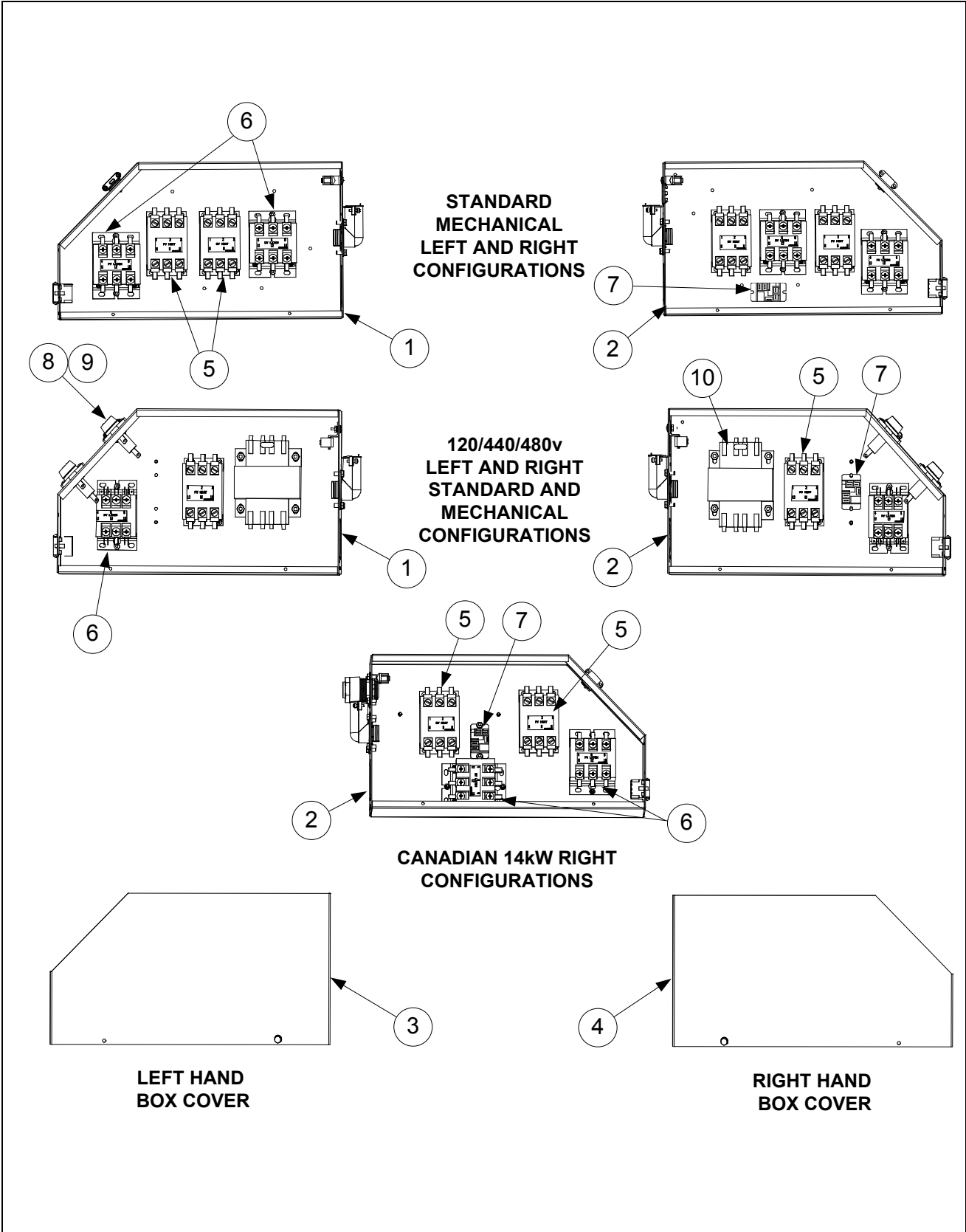

2.4.2 Left and Right Contactor Box Configurations cont.

NOTES: Left and right contactor box assemblies are mirror images of one another. With the exception of the box itself, all components of a left-hand assembly are the same as those in the corresponding right-hand assembly and vice versa except for the hood relay which occurs in the right or large box only. The configurations illustrated show all possible components, but a particular configuration may not have all the components shown.

ITEM	PART #	COMPONENT
1	106-8658	Box Assembly, Left Contactor
2	106-8660	Box Assembly, Right Contactor
3	221-0482	Cover, Left Hand Contactor Box
4	222-0482	Cover, Right Hand Contactor Box
9	807-0070	Terminal, Ground Lug
√ 5	807-2284	Contactor, 24V 50 Amp Mechanical (Heat)
√ 6	810-1202	Contactor, 24V 40 Amp Mechanical (Latch)
7	807-1683	Relay, Hood 12VDC
8	807-0922	Holder, Bus Fuse
9	807-2278	Fuse, 20 Amp
10	807-0064	Transformer, 480V/120V 150VA
*	221-0610	Bracket, Left Hand Contactor Box Mounting
*	222-0610	Bracket, Right Hand Contactor Box Mounting
*	807-4316	McDonald's Cordset, 120V 5-Wire
*	807-4317	McDonald's Cordset, Europe 3-Wire Single Phase
*	807-0012	Relay, Tilt Switch 18 Amp 1/3 HP 24 V Coil

* Not illustrated.

√ Recommended parts.

2.4.3 Heating Element Assemblies and Hardware

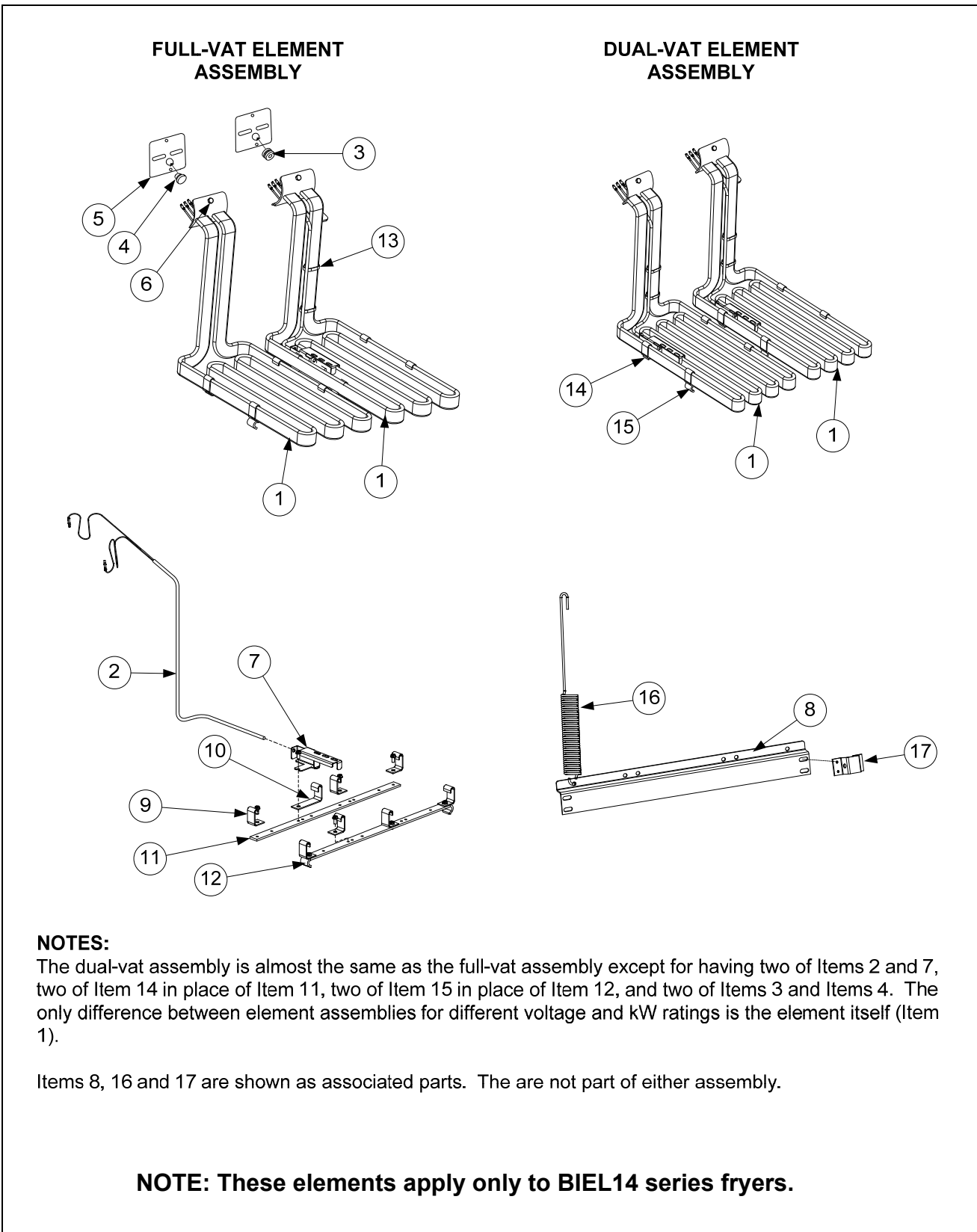

2.4.3 Element Assemblies and Hardware cont.

ITEM	PART #	COMPONENT
1		Element
√	826-2198	200V 7.0 kW (220V 8.5kW used in some export 3-phase 4-wire WYE units)
	826-2192	208V 7.0 kW
	826-2200	220V 7.0 kW (240V 8.5kW used in some export 3-phase 4-wire WYE units)
	826-2193	230V 7.0 kW
	826-2199	230V/400V 7.0/8.5 kW (used in some export 3-phase 4-wire WYE units)
	826-2194	240V 7.0 kW
	826-2196	480V 7.0 kW
√ 2	826-2212	Probe, Temperature RE – includes tie wraps and grommet.
3	816-0681	Grommet, Probe
4	816-0480	Plug, .375-inch Dome
5	816-0688	Gasket, Element
6	809-1003	Screw, 10-32 X 3/8-inch Hex Head SS
*	809-0766	Nut, 10-32 Keps Hex Head SS
*	230-4028	Wrench, Element Tube Nut Spanner
7	230-3714	Bracket, Temperature Probe 7.0kW
	230-0784	Bracket, Temperature Probe 8.5kW (used in some export 3-phase 4-wire WYE units)
8	220-0464	Bracket, Lower Spring
9	910-2042	Clamp, Element (Short)
10	230-0781	Clamp, Element (Long)
11	230-4902	Support, Full-Vat Element Rear
12	230-4101	Support, Full-Vat Element Front
13	809-0567	Tie-Wrap, Metal
14	230-4903	Support, Dual-Vat Element Bottom Rear (use 230-8163 for fish vat)
15	230-4103	Support, Dual-Vat Element Bottom Front
16	810-3030	Spring, Element Lift Left
	810-3131	Spring, Element Lift Right
17	220-0733	Bracket, Lower Spring Mating

* Not illustrated.

√ Recommended parts.

2.4.4 Element Tube Assemblies

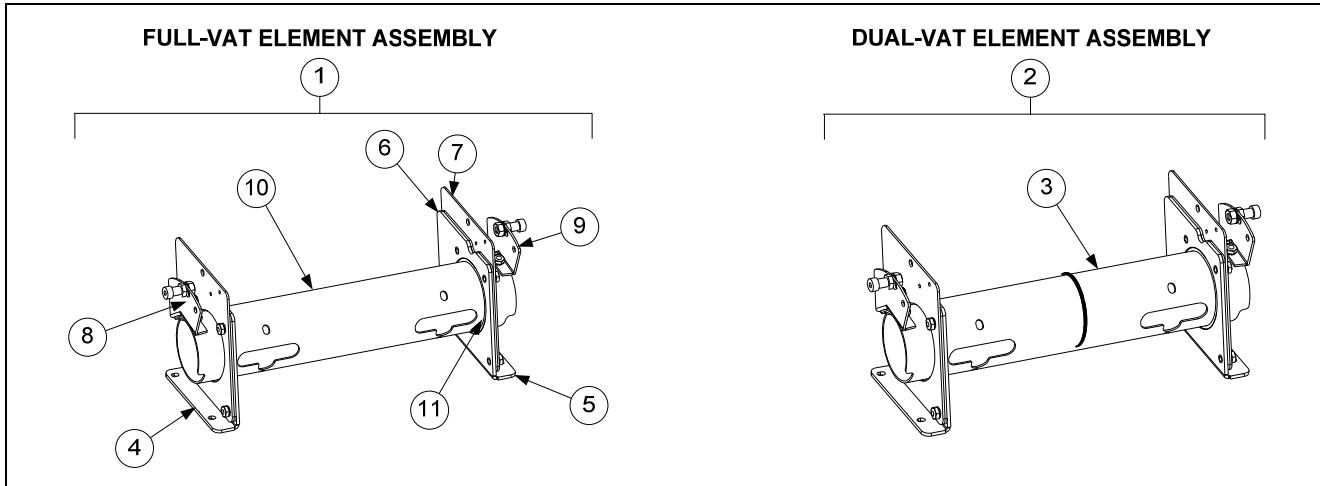

ITEM	PART #	COMPONENT
1	108-0297SP	Tube Assembly, Full-Vat 14kW
	108-0293	Tube Assembly, Full-Vat 17
2	108-0298SP	Tube Assembly Dual-Vat 14kW
	108-0295	Tube Assembly Dual-Vat 17
3	810-3246	Bushing and Tube Assembly, Dual-Vat
4	108-0315	Bracket Assembly, LH Element Tube Support
5	108-0316	Bracket Assembly, RH Element Tube Support
6	220-0122	Plate, Element Tube Support Inner
7	220-0123	Plate, Element Tube Support Outer
8	106-7651	Bracket Assembly, LH Upper Spring <i>(use 106-6569 for 17kW)</i>
9	106-7652	Bracket Assembly, RH Upper Spring <i>(use 106-6570 for 17kW)</i>
10	810-2992	Tube, Full Vat Element Mounting
11	810-2993	Bushing, Tube End Teflon
*	826-2598	Kit, Tilt Switch
*	807-4742	Switch, Long Lever High Temp

* Not illustrated.

2.4.5 Controllers

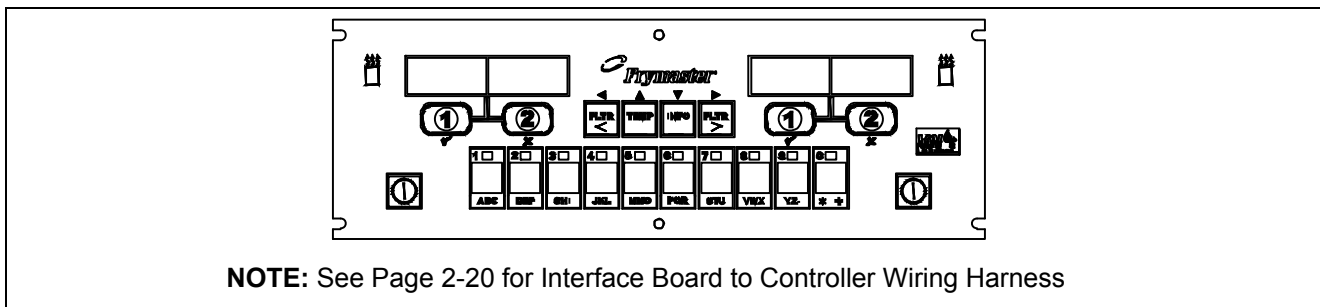

ITEM	PART #	COMPONENT
√ 1	108-4351	Replacement M3000 Manual LOV Controller

√ Recommended parts.

2.4.6 Wiring

2.4.6.1 Contactor Box Wiring Assemblies – 12-Pin Dual-Vat C-1

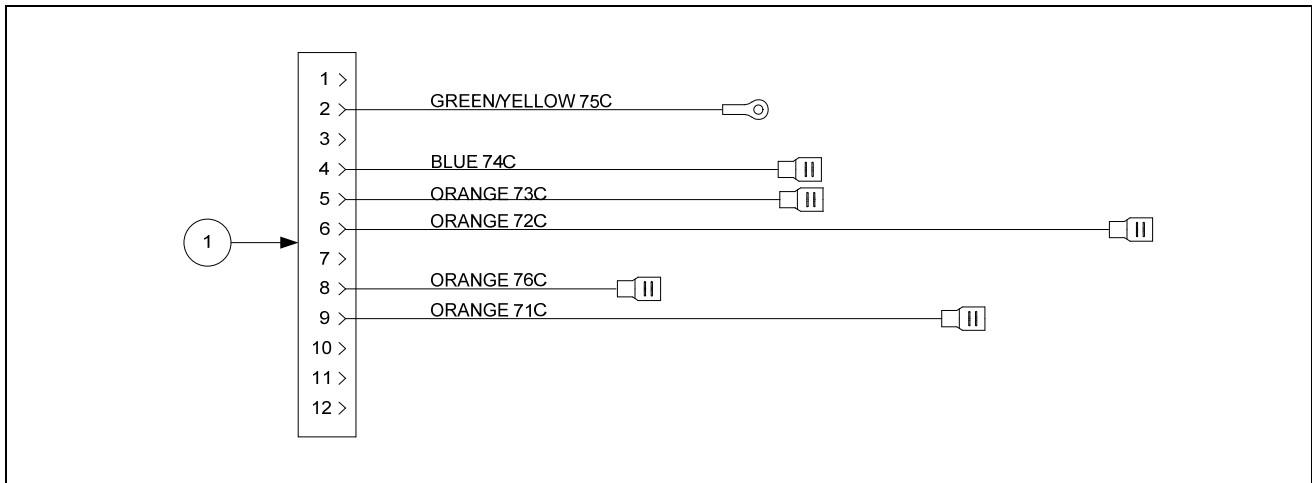

ITEM	PART #	COMPONENT
1	106-5980SP	Contactor Box Harness Assembly Dual Vat Standard (See wiring diagrams on pages 1-35 thru 1-36.)

2.4.6.2 Contactor Box Wiring Assemblies – 12-Pin Full-Vat C-1

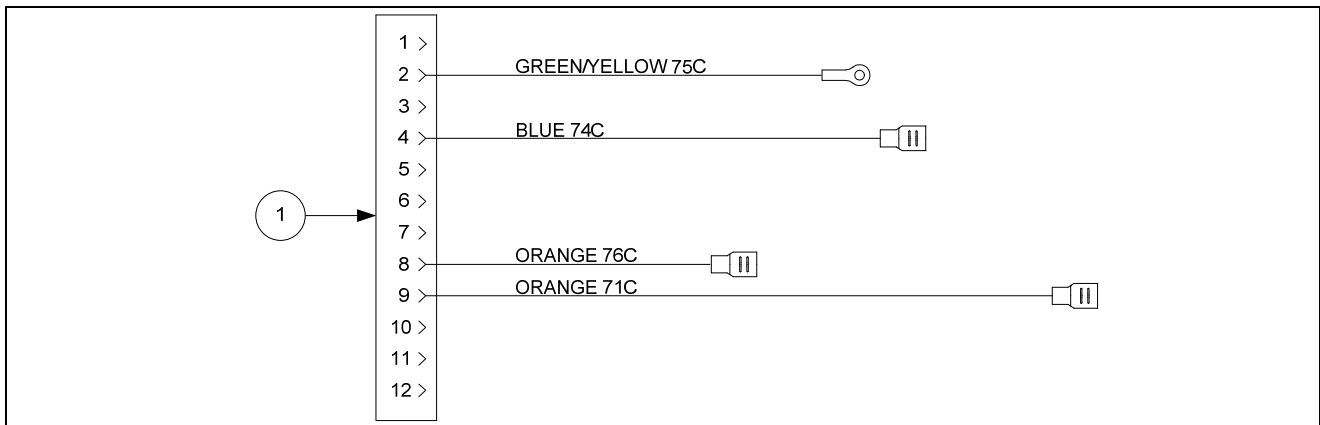

ITEM	PART #	COMPONENT
1	106-6031SP	Contactor Box Harness Assembly Full Vat Standard (See wiring diagrams on pages 1-35 thru 1-36.)

2.4.6.3 Contactor Box Wiring Assembly – 6-Pin (Left Element)

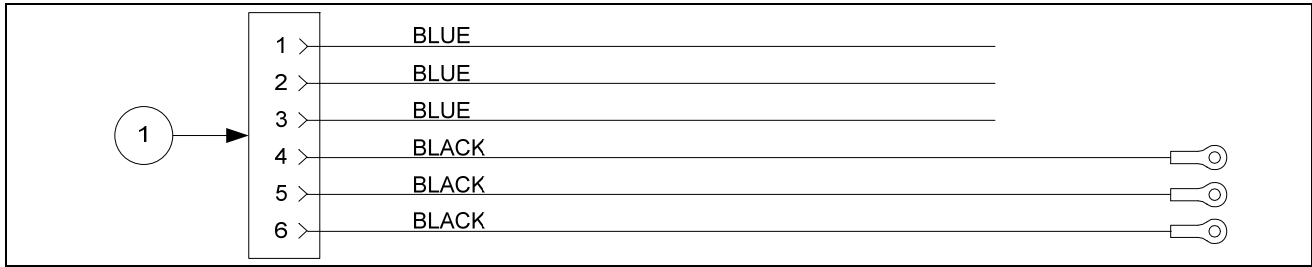

ITEM	PART #	COMPONENT
1	106-8744SP	14/17 kW Mechanical Contactor

2.4.6.4 Contactor Box Wiring Assembly – 9-Pin (Right Element)

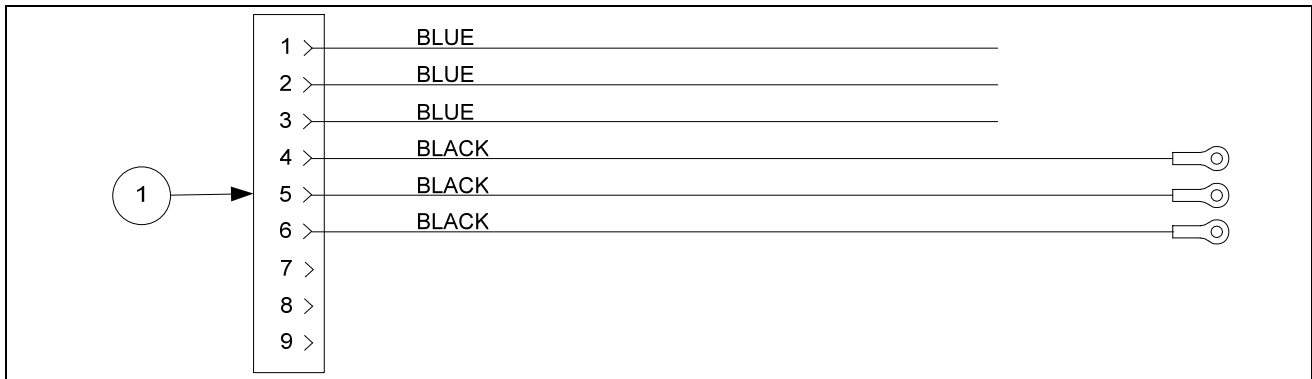

ITEM	PART #	COMPONENT
1	106-8745SP	14/17 kW Mechanical Contactor

2.4.6.5 Main Wiring Harnesses

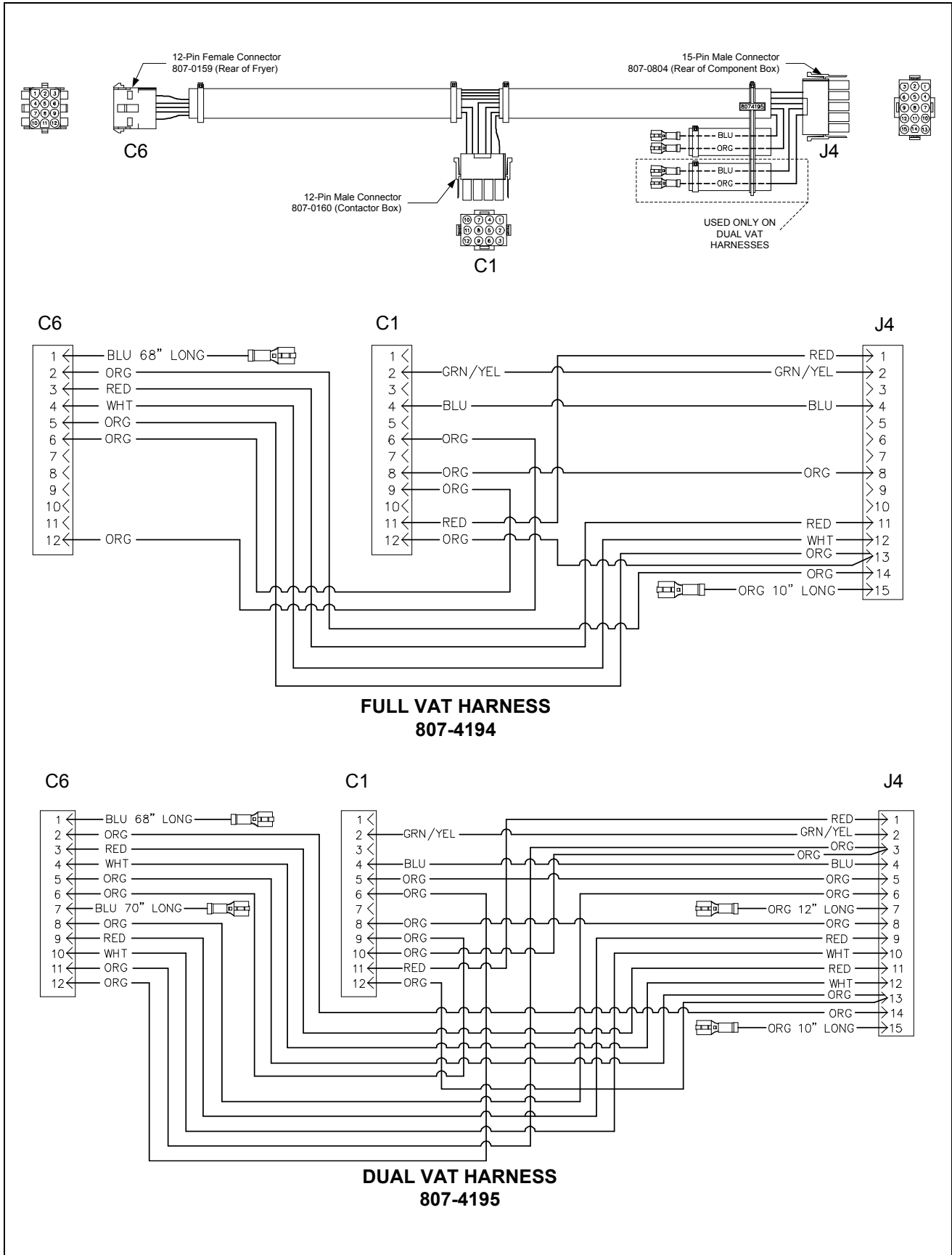

2.4.6.6 Component Box, Filter Pump and Basket Lift Wiring Harnesses

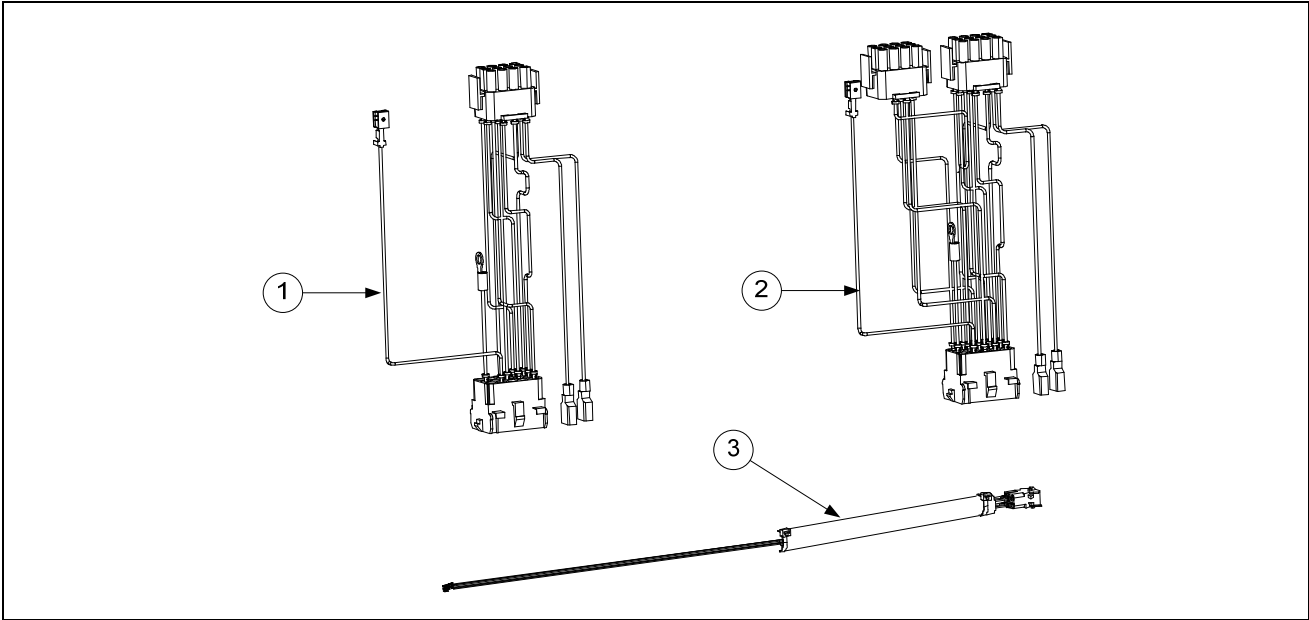

ITEM	PART #	COMPONENT
1	106-5750SP	Full Vat Control Harness J4 to J2 <i>(Standard)</i>
2	106-5751SP	Dual Vat Control Harness J4 to J1 and J2 <i>(Standard)</i>
3	108-0490SP	Filter Pump C2 to Component Box Wiring Harness

2.4.6.7 Component Box to Filter Pump Harness

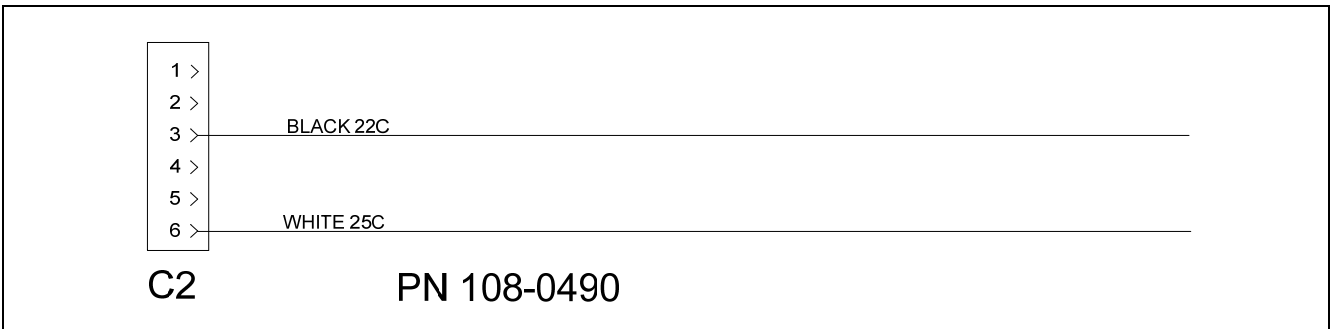

2.4.6.8 Interface Board to Controller Wiring Harness – 15-Pin

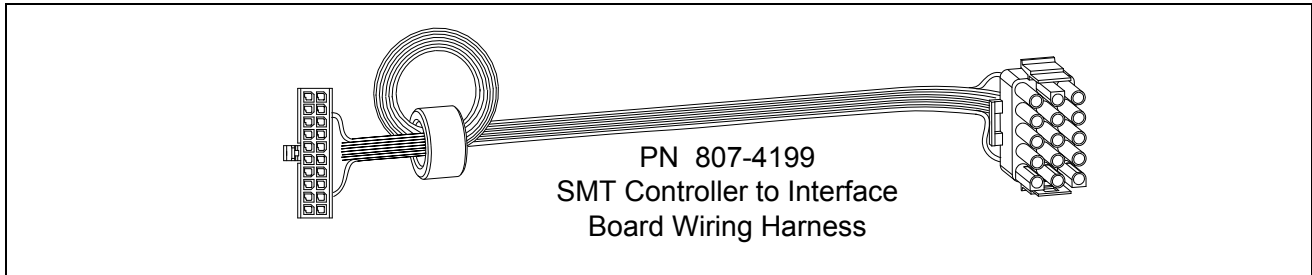

2.4.6.9 Manual LOV 3000 Wiring Harnesses

ITEM	PART #	COMPONENT
*	807-4546	Controller Communication (<i>used from Controller to Controller</i>)
*	807-4573	Controller Locator Wire (<i>used from Controller to Interface Board</i>) See table A in wiring diagram on page 1-23 for locator pin positions.
*	807-4552	Communications Terminator (<i>used on Controller pin J6 to terminate network</i>)
√ *	807-4660PK	SMT Pin Service Repair Kit
√ *	230-2345	SMT Pin Extractor

* Not illustrated.

√ Recommended parts.

See page 1-19 for Pin Positions.

2.5 Filtration System Components

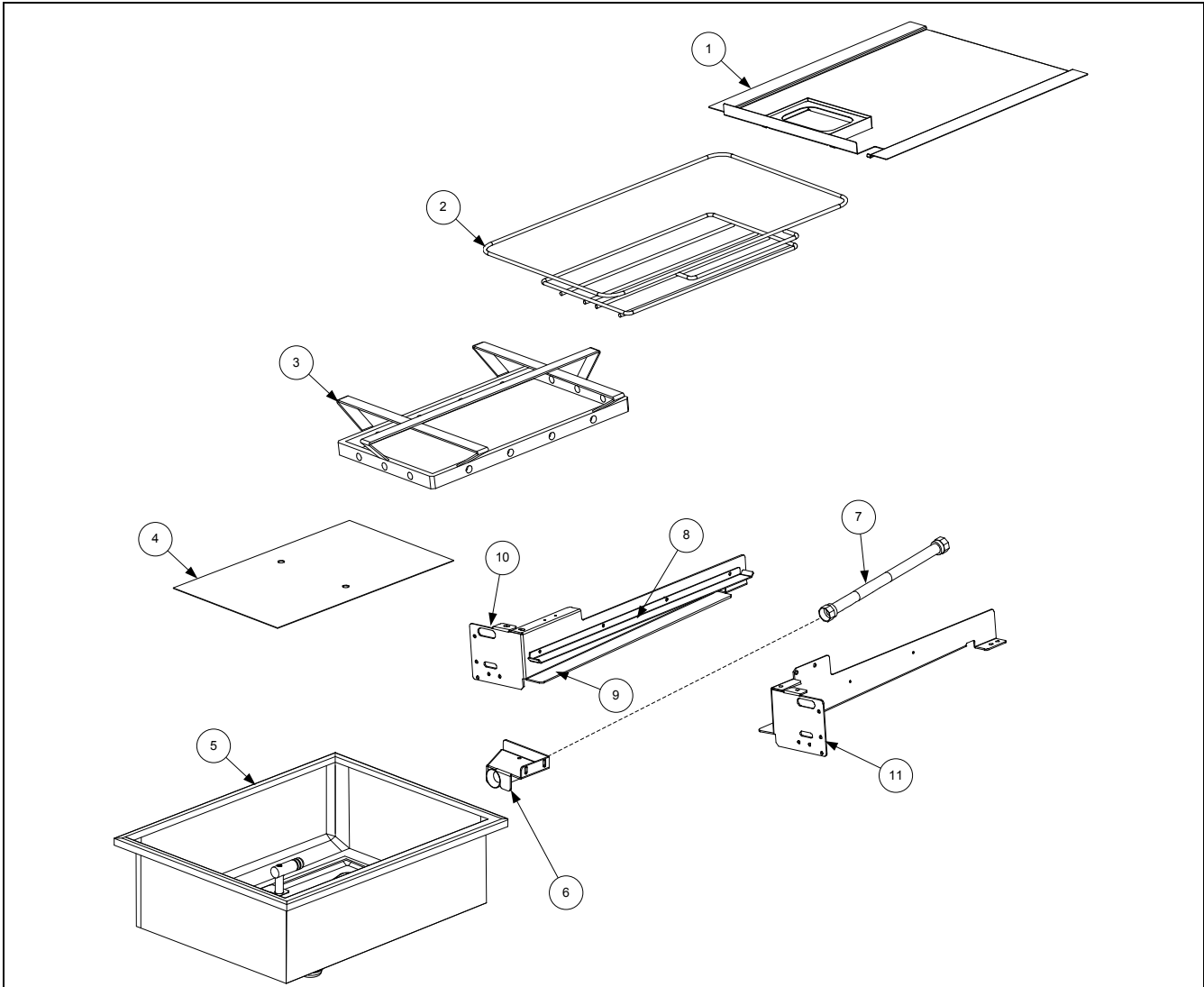

ITEM	PART #	COMPONENT
1	823-7910	Lid, Half Size Filter Pan
2	810-3288	Crumb Tray, Half Size Filter Pan
3	810-3289	Hold-Down Ring 11.20 x 19.10, Half Size Filter Pan
4	812-2024	SanaGrid Filter Screen, Half Size Filter Pan
5	108-3872SP	Pan, Half Size Filter Pan with casters
	813-0568	Plug, 1/8-inch Socket Head Pipe (used with Item 5; two required)
√ *	826-1392	O-Ring (Pkg. of 5; used with Item 5)
6	810-2807	Caster, 2" Rigid
7	823-6458	Suction Tube Assembly
8	230-6616	Rail, Upper Filter Pan Left/Right
9	230-6619	Rail, Lower Filter Pan Left/Right
10	220-3275	Support, Left Filter Pan
11	220-3710	Support, Right Filter Pan
12	810-1055	Flexline, 11.50-inch Oil Return

* Not illustrated.

√ Recommended parts.

2.6 Filter Pump, Motor and Associated Components

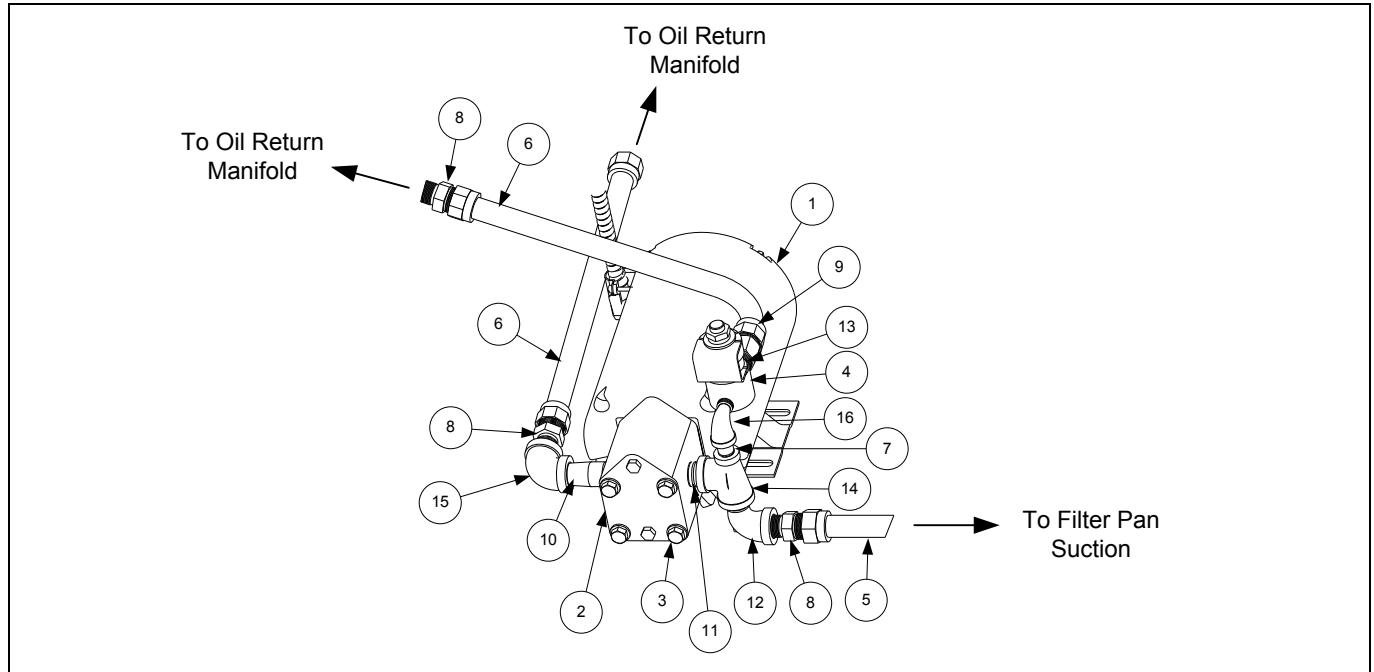

ITEM	PART #	COMPONENT
1		Motor and Gasket Kit
	826-1785	100V 50/60 Hz
√	826-1712	115V 50/60 Hz
√	826-1756	208V 50/60 Hz
	826-1270	220-240V 50/60 Hz
	826-1755	250V 50/60 Hz
2	826-1264	Pump and Gasket Kit, Viking 4 GPM (includes gasket and cap screws below)
	816-0093	Gasket, Pump/Motor
3	809-0514	Cap Screw, 5/16-inch-18 4.50" NC Hex (<i>Connects pump to motor.</i>)
*	807-11973	Viking Pump Seal Kit
*	108-0649	Heater Strip Assembly, 100-120V 25W 18"
*	106-5912	Heater Strip Assembly, 208-250V 25W 18"
4	807-2484	Valve, Solenoid 1/4-inch" NPT
5	810-1055	Flexline, 11.50-inch Oil Return
6	810-1057	Flexline, 13-inch Oil Return
7	813-0838	Nipple, 1/4-inch NPT BM Close
8	810-1668	Adapter, 5/8-inch to 1/2-inch NPT Male
9	810-1669	Adaptor, Female 7/8-inch OD x 1/2-inch
10	813-0298	Nipple, 1/2-inch x 2-inch BM
*	811-1071	Tubing, 1/4-inch OD Teflon Vent (sold by the foot)
11	813-0022	Nipple, 1/2-inch x Close NPT BM
12	813-0165	Elbow, ST 1/2-inch x 1/2-inch NPT 90° BM
13	813-0304	Bushing, 1/2-inch x 1/4-inch BM Flush
14	813-0530	Tee, Reducing 1/2-inch x 1/4-inch x 1/2-inch
15	813-0537	Elbow, 1/2-inch 90° BM
16	813-0543	Elbow, Street 1/4-inch NPT BM

* Not illustrated.

√ Recommended parts.

2.7 Frypot Assemblies and Associated Parts

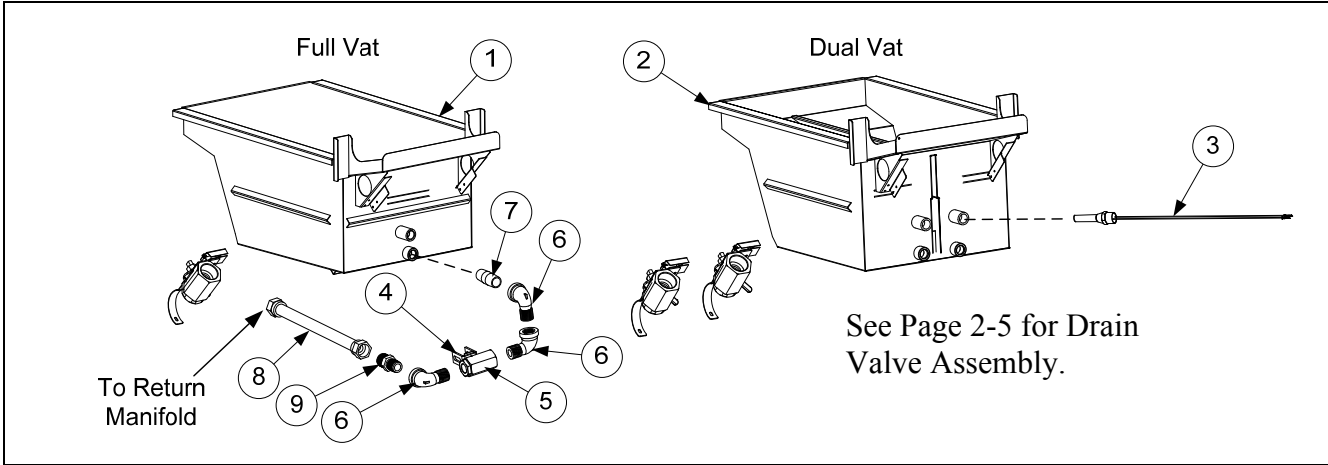

ITEM	PART #	COMPONENT
1	823-8057	Frypot, Full-Vat Manual LOV
2	823-8047	Frypot, Dual-Vat Manual LOV
	824-2210	Riser, DV Frypot
3		Thermostat Assembly, High-Limit Standard
	826-2454	Non-CE Full Vat 425°F (218°C) (14 and 17kW FV) (Color Coded Black 806-7543)
	826-2456	Non-CE Full Vat 435°F (224°C) (17kW and 14kW DV) (Color Coded Red 806-8035)
	826-2455	CE Full Vat 415°F (213°C) (14kW and 17kW CE) (Color-Coded Yellow 806-8132)
4	200-5438	Handle, Valve Rear Flush
*	900-2935	Retainer, Nut Oil Return Valve
5	810-0278	Valve, Return ½" Ball
6	813-0165	Elbow, St ½" x ½" NPT 90° BM
7	813-0298	Nipple, ½" x 2.00" NPT BM Pipe
8	810-1067	Flexline, ⅝" OD x 8.50" Long Return Oil
9	810-1668	Adaptor, Male ⅝" OD x ½"

* Not illustrated.

√ Recommended parts.

2.8 Oil Return System Components

Typical Rear-Flush Oil Return Plumbing

Full-vat rear-flush plumbing is shown on the left side of the oil return manifold; dual-vat plumbing is shown on the right side. Plumbing for a two-fryer battery is illustrated, most of the components except the oil return manifold and a few fittings are the same regardless of the number of fryers in the battery. Return valve assemblies are shown on preceding page.

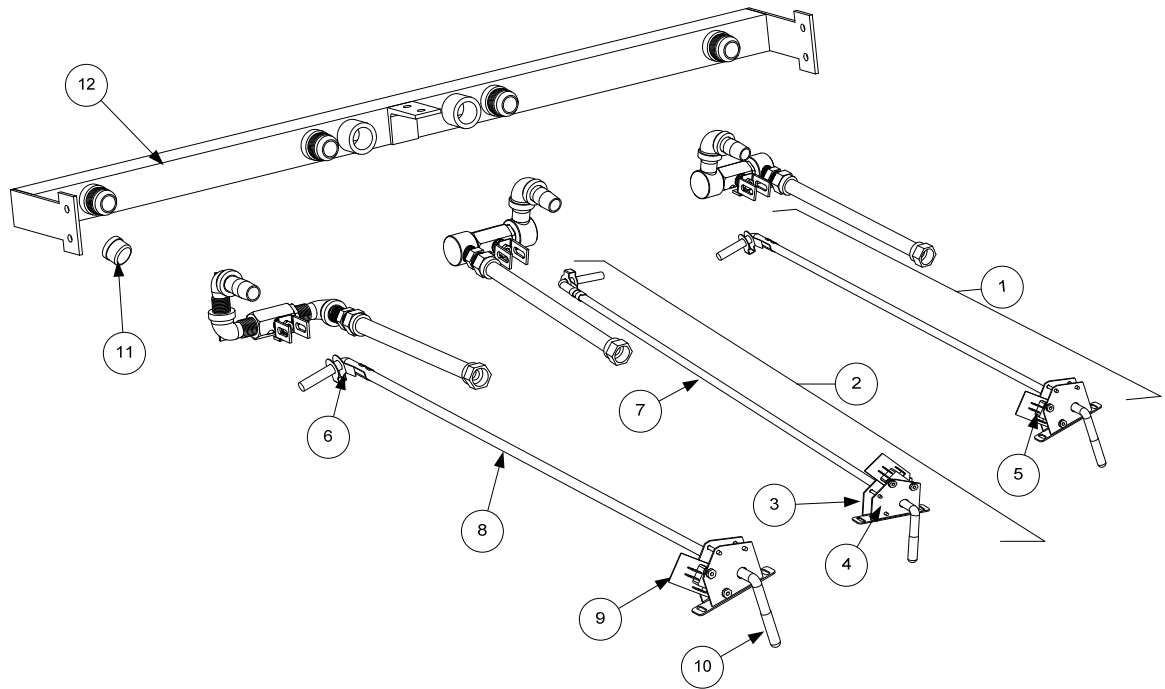

ITEM	PART #	COMPONENT
1	108-2433	Handle Assembly, Full-Vat and Right Dual-Vat Rear Flush Complete
2	108-2432	Handle Assembly, Left Dual-Vat Rear Flush Complete
3	106-5595	Bracket Assembly, Microswitch
4	200-5401	Bracket, Handle Retainer
5	807-2103	Microswitch, Straight Lever
6	809-0601	Clip, Clevis
7	810-3887	Handle, Oil Return Left Dual Vat Rod
8	810-3886	Handle, Oil Return Right Dual Vat and Full Vat Rod
9	816-0220	Insulation, Oil Return Microswitch
10	816-0643	Grip, Oil Return Valve Handle
11	813-0907	Cap, 15/16-inch Valve Safety
12		Manifolds
*	810-3015	Manifold, Two-Station Fryer
*	810-3016	Manifold, Three-Station Fryer
	810-3017	Manifold, Four-Station Fryer
*	810-3018	Manifold, Five-Station Fryer

* Not illustrated.

2.9 Wiring Connectors, Pin Terminals, and Power Cords

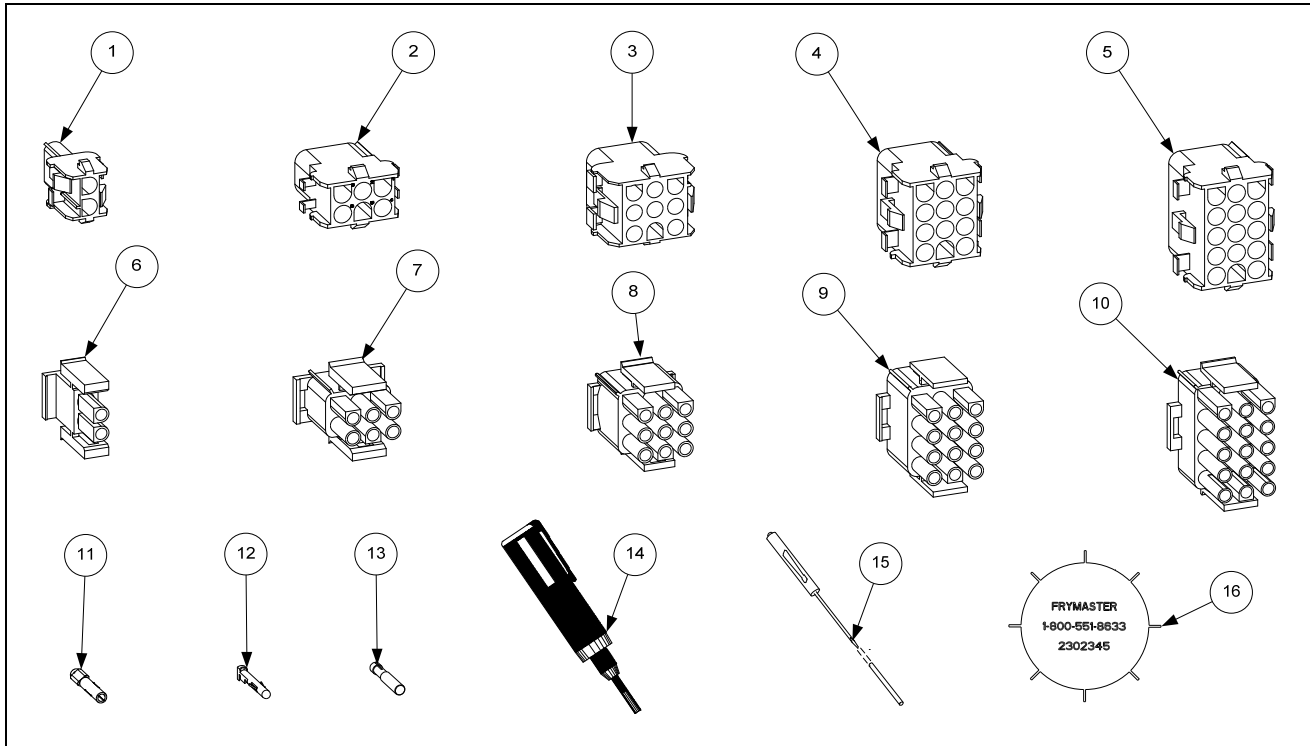

ITEM	PART #	COMPONENT
Power Cords		
*	807-0154	100/120V–15A 3-wire, w/grounded plug
*	807-4317	100/208/240V-16A 3-Wire with Plug LOV CE
*	807-1685	100/208/240V–18A 3-wire, w/o plug
*	807-4316	120V 5-wire, w/grounded plug LOV
*	807-3817	208/240V 3-Phase 4-wire w/grounded plug
*	807-5105	208/240V 3-Phase 4-wire w/grounded plug 105” CE 4 battery or larger
Connectors		
1	807-1068	2-Pin Female
2	807-0158	6-Pin Female
3	807-0156	9-Pin Female
5	807-0159	12-Pin Female
5	807-0875	15-Pin Female
6	807-1067	2-Pin Male
7	807-0157	6-Pin Male
8	807-0155	9-Pin Male
9	807-0160	12-Pin Male
10	807-0804	15-Pin Male
11	826-1341	Terminal, Female Split Pin (Pkg of 25)
12	826-1342	Terminal, Male Split Pin (Pkg of 25)
13	807-2518	Plug, Mate-N-Lock (Dummy Pin)
14	807-0928	Extract Tool Pin Pusher
15	806-4855	Pin Pusher Screwdriver Assembly
16	230-2345	SMT Pin Extractor
*	807-4660PK	SMT Pin Service Repair Kit

* Not illustrated.

2.10 Fasteners

ITEM	PART #	COMPONENT
*	809-0429	Bolt, 1/4-inch – 20 x 2.00-inch Hex Head ZP Tap
*	809-0131	Bolt, 1/4-inch -20 x 3/4-inch Hex
*	809-1020	Cap Screw, 5/16-inch-18 5.50" NC Hex (<i>Connects pump to motor.</i>)
*	809-0448	Clip, Tinnerman
*	826-1366	Nut, 4-40 Keps Hex (Pkg. of 25) (809-0237)
*	826-1358	Nut, 6-32 Keps Hex (Pkg. of 25) (809-0049)
*	809-0247	Nut, 8-32 Keps Hex
*	826-1376	Nut, 10-32 Keps Hex (Pkg. of 10) (809-0256)
*	809-0766	Nut, 10-32 Keps Hex SS
*	809-0581	Nut, 1/2 NPT Locking
*	809-0020	Nut Cap 10-24 NP
*	826-1372	Nut Grip 1/4-inch 1/4-20 Hex NP (Pkg. of 10) (809-0059)
*	809-0417	Nut Flange 1/4-inch 1/4-20 Serr
*	809-0535	Nut, "T" 1/4-inch-20 x 7/16 SS
*	809-0495	Nut, 1/4-inch – 20 Press
*	809-0540	Nut, Lock 1/2-inch-13 Hex 2-Way ZP
*	826-1359	Screw, 4-40 x 3/4-inch Slotted Round Head (Pkg. of 25) (809-0354)
*	826-1365	Screw, 6-32 x 3/8-inch Slot Head (Pkg. of 25) (809-0095)
*	809-0357	Screw, 6 x 3/8-inch Phillips Head NP
*	809-0359	Screw, 8 x 1/4-inch Hex Washer Head
*	809-0360	Screw, 8 x 3/8-inch Hex Washer Slot Head
*	826-1371	Screw, 8 x 1/2-inch Hex Head ZP (Pkg. of 25) (809-0361)
*	809-0364	Screw, 8 x 5/8-inch Hex Washer Head ZP
*	809-0518	Screw, 8-32 x 3/8-inch Hex Washer Slotted Head SS
*	809-0104	Screw, 8-32 x 1/2-inch Slotted Head ZP
*	826-1363	Screw, 8-32 x 1/2-inch NP (Pkg. of 25) (809-0103)
*	826-1360	Screw, 10-24 x 5/16-inch Round Slot Head ZP (Pkg. of 25) (809-0024)
*	826-1330	Screw, 10-32 x 3/8-inch Slot Head SS (Pkg. of 25) (809-0117)
*	809-1003	Screw, 10-32 x 3/8-inch Hex Trim Head SS
*	809-0270	Screw, 10-32 x 1/2-inch Phillips Head ZP
*	826-1375	Screw, 10-32 x 3/4-inch Hex Trim Head SS (Pkg. of 5) (809-0401)
*	809-1000	Screw, 10-32 x 1 1/4-inch Hex Sck C/S
*	826-1374	Screw, 10 x 1/2-inch Hex Head (Pkg. of 25) (809-0412)
*	809-0266	Screw, 10 x 1/2-inch Phillips Head ZP
*	809-0434	Screw, 10 x 3/8-inch Hex Washer Head NP
*	809-0123	Screw, 10 x 3/4-inch Slot Head
*	826-1389	Screw, 1/4-20 x 3/4-inch Hex Head ZP (Pkg. of 10) (809-0131)
*	809-0582	Washer 1/2 NPT Locking
*	809-0184	Washer, #10 LK ZP
*	809-0190	Washer, .625 X .275 X 40 Flat SS
*	809-0191	Washer, Lock 1/4 Spring ZP
*	809-0193	Washer, Flat 1/4 Nylon
*	809-0194	Washer, Flat 5/16 ZP



Frymaster, L.L.C., 8700 Line Avenue, Shreveport, Louisiana 71106

TEL 1-318-865-1711 FAX (Parts) 1-318-219-7140 FAX (Tech Support) 1-318-219-7135

PRINTED IN THE UNITED STATES

SERVICE HOTLINE
1-800-551-8633

819-6963
JULY 2012