

# FilterQuick™ FQE30

## Electric Fryer

### Wiring Diagrams

This manual is updated as new information and models are released. Visit our website for the latest manual.



8 1 9 7 2 2 5

Part Number: FRY\_D\_8197225 09/2017

 **DANGER**

**Prior to movement, testing, maintenance and any repair on your Frymaster fryer, disconnect ALL electrical power from the fryer.**

# FILTERQUICK™ FQE30 SERIES ELECTRIC FRYER

## Table of Contents

---

### SECTION 1: Wiring Diagrams

1.1 Control Wiring .....	1-1
1.2 Contactor Box – Delta Configuration .....	1-2
1.3 Contactor Box – Delta Configuration 14kW/17kW EPRI/TRIAC .....	1-3
1.4 Contactor Box – WYE Configuration .....	1-4
1.5 Contactor Box – WYE Configuration 14kW/17kW EPRI/TRIAC.....	1-5
1.6 Simplified Wiring .....	1-6
1.6.1 Simplified Wiring with Push Button.....	1-6
1.6.2 Simplified Wiring with Push Pull Handles.....	1-7
1.7 Shortening Melting Unit .....	1-8
1.8 Modular Basket Lift 100-120V .....	1-9
1.9 Modular Basket Lift 208-250V .....	1-10



## 1.2 Contactor Box – Delta Configuration

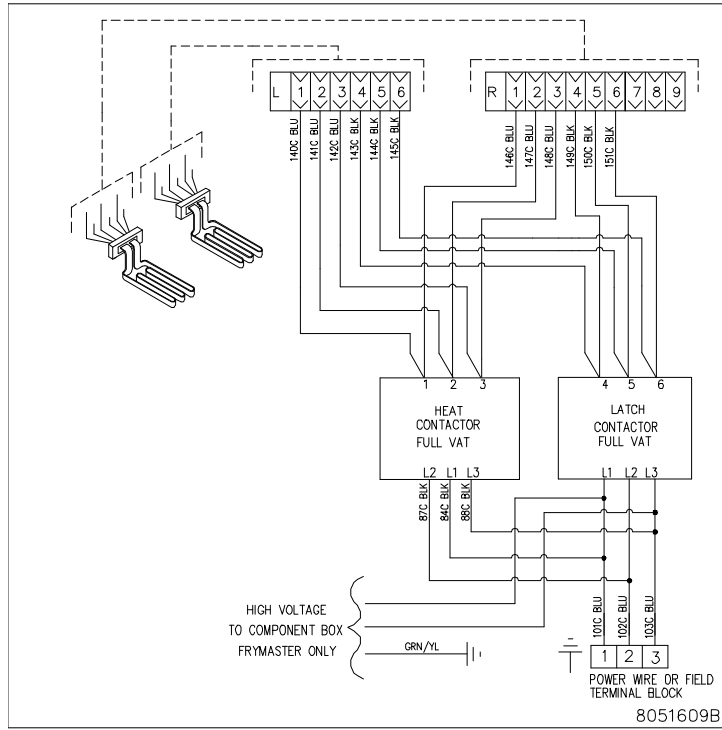

**FULL VAT**

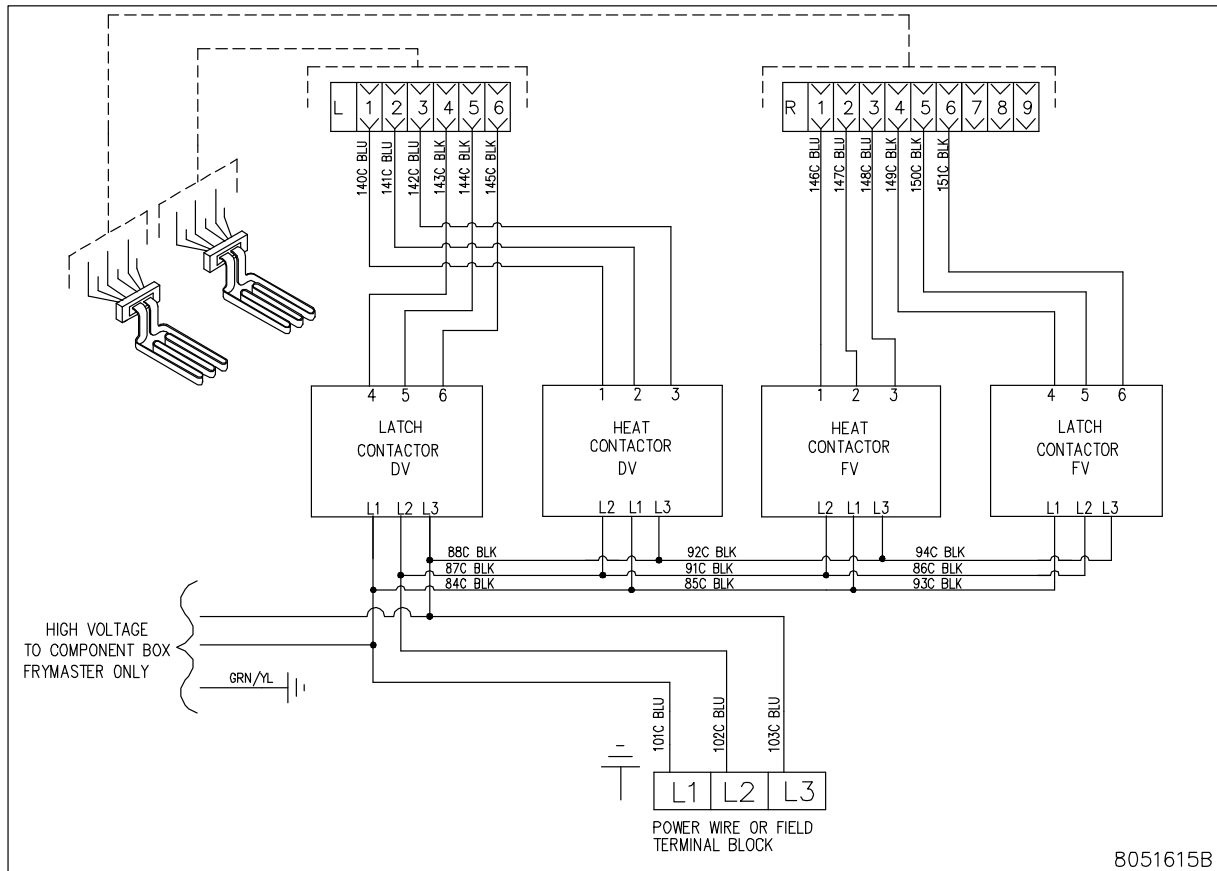

**DUAL VAT**

### 1.3 Contactor Box – Delta Configuration 14kW/17kW EPRI/TRIAC

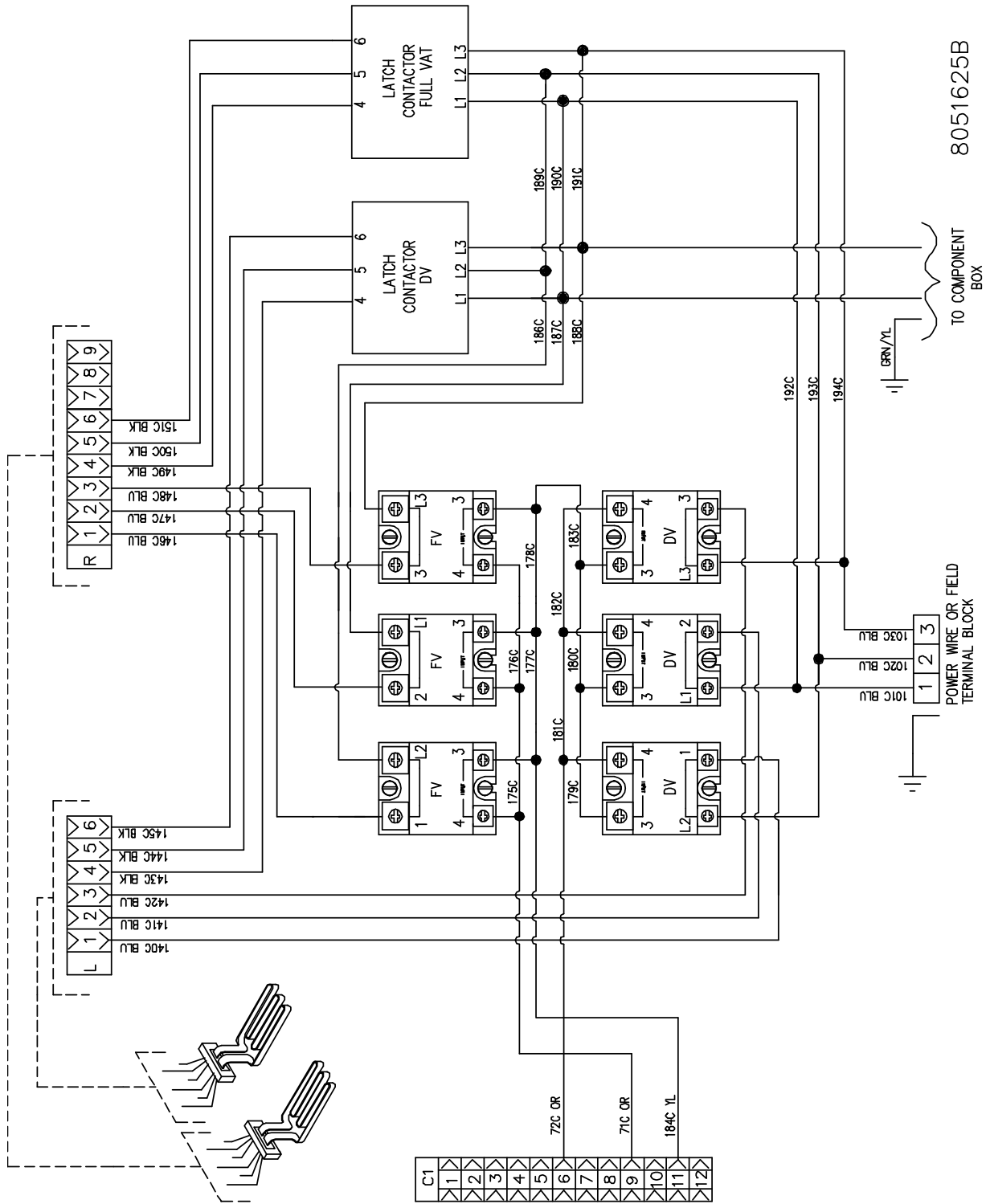

14kW / 17kW EPRI/TRIAC SSR ELEMENT WIRING

# 1.4 Contactor Box – WYE Configuration

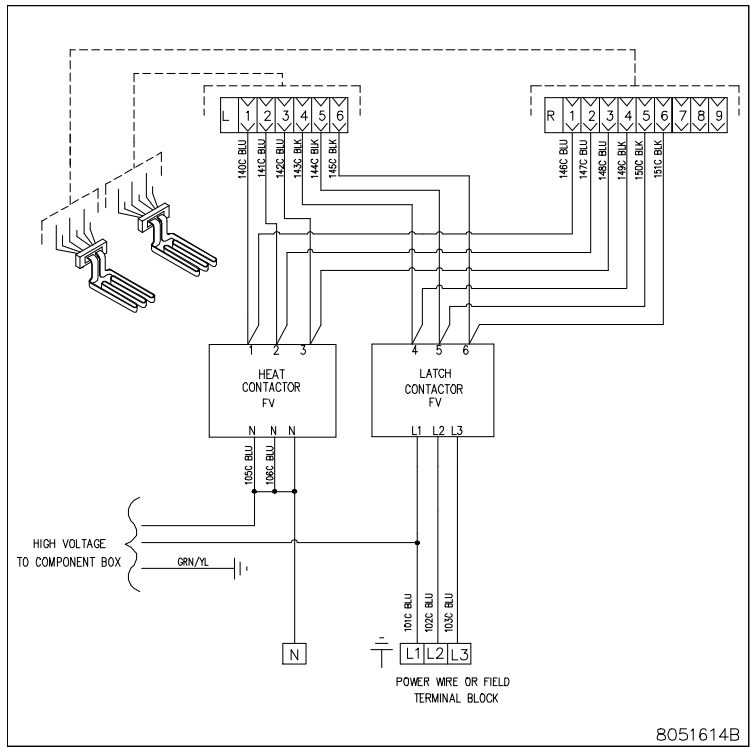

**FULL VAT**

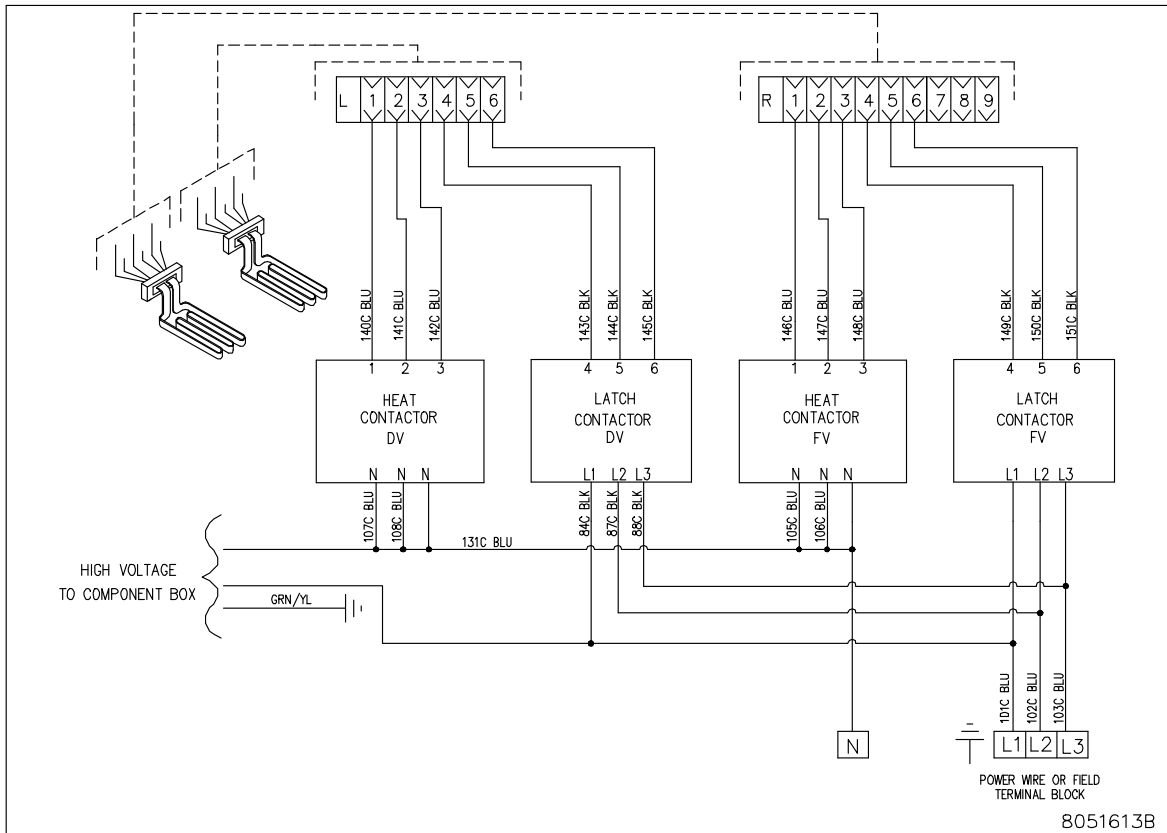

**DUAL VAT**







# 1.6.2 FilterQuick™ Electric Simplified Wiring with Push Pull Handles

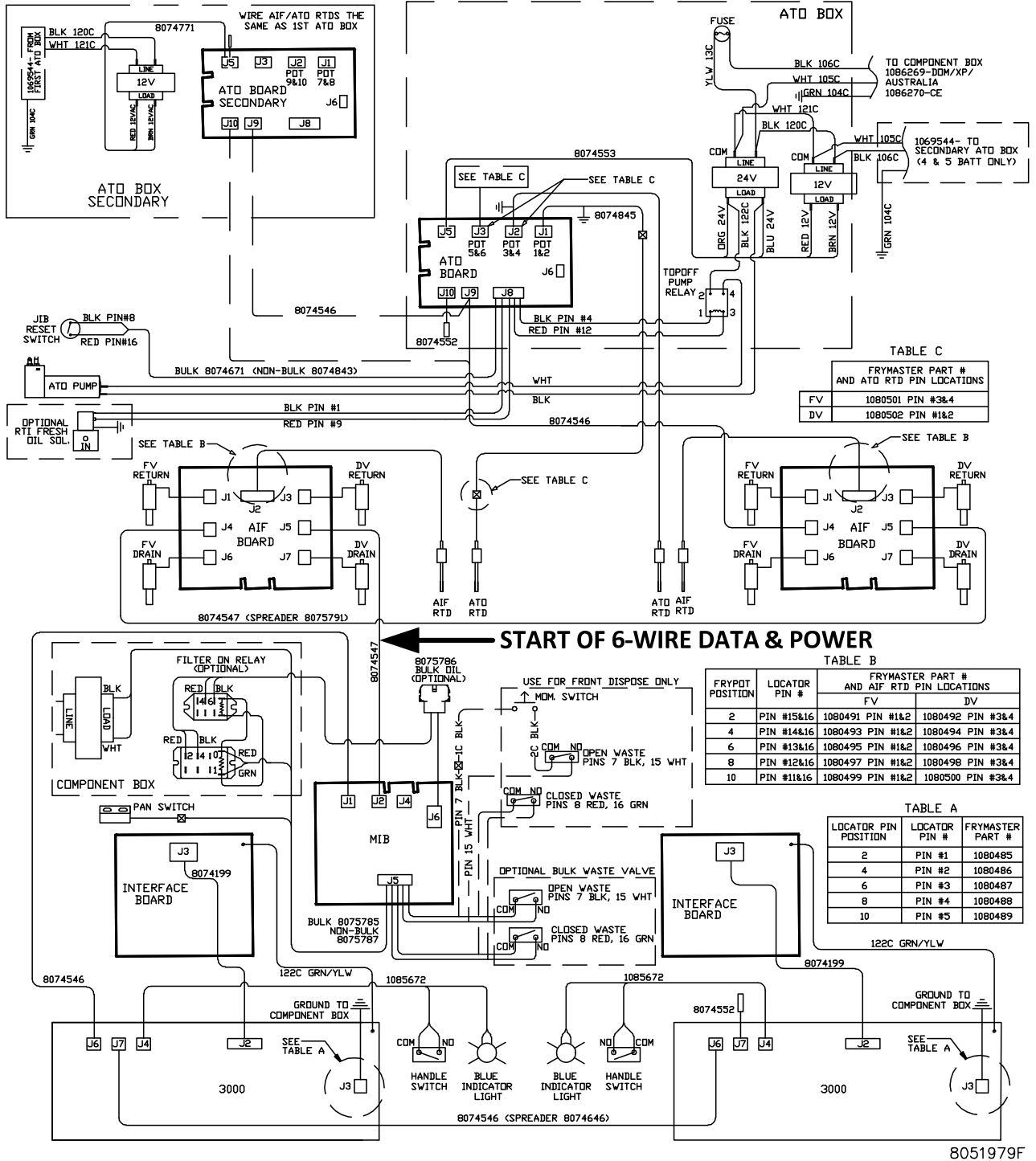

# 1.7 Shortening Melting Unit Wiring Diagram

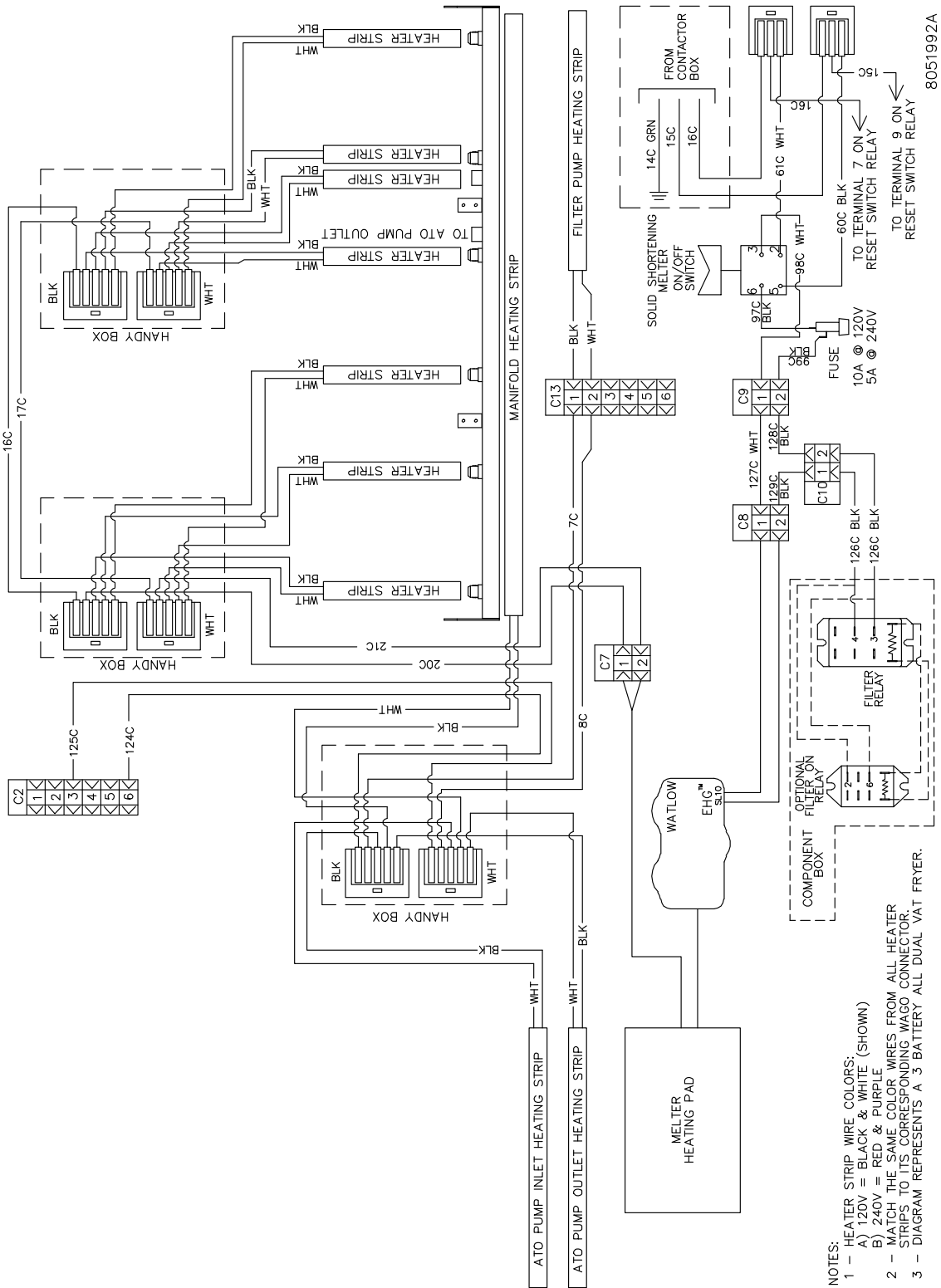

- NOTES:
- 1 - HEATER STRIP WIRE COLORS:
    - A) 120V = BLACK & WHITE (SHOWN)
    - B) 240V = RED & PURPLE
  - 2 - MATCH THE SAME COLOR WIRES FROM ALL HEATER STRIPS TO ITS CORRESPONDING WAGO CONNECTOR.
  - 3 - DIAGRAM REPRESENTS A 3 BATTERY ALL DUAL VAT FRYER.

8051992A

# 1.8 Modular Basket Lift Wiring Diagram 100-120V

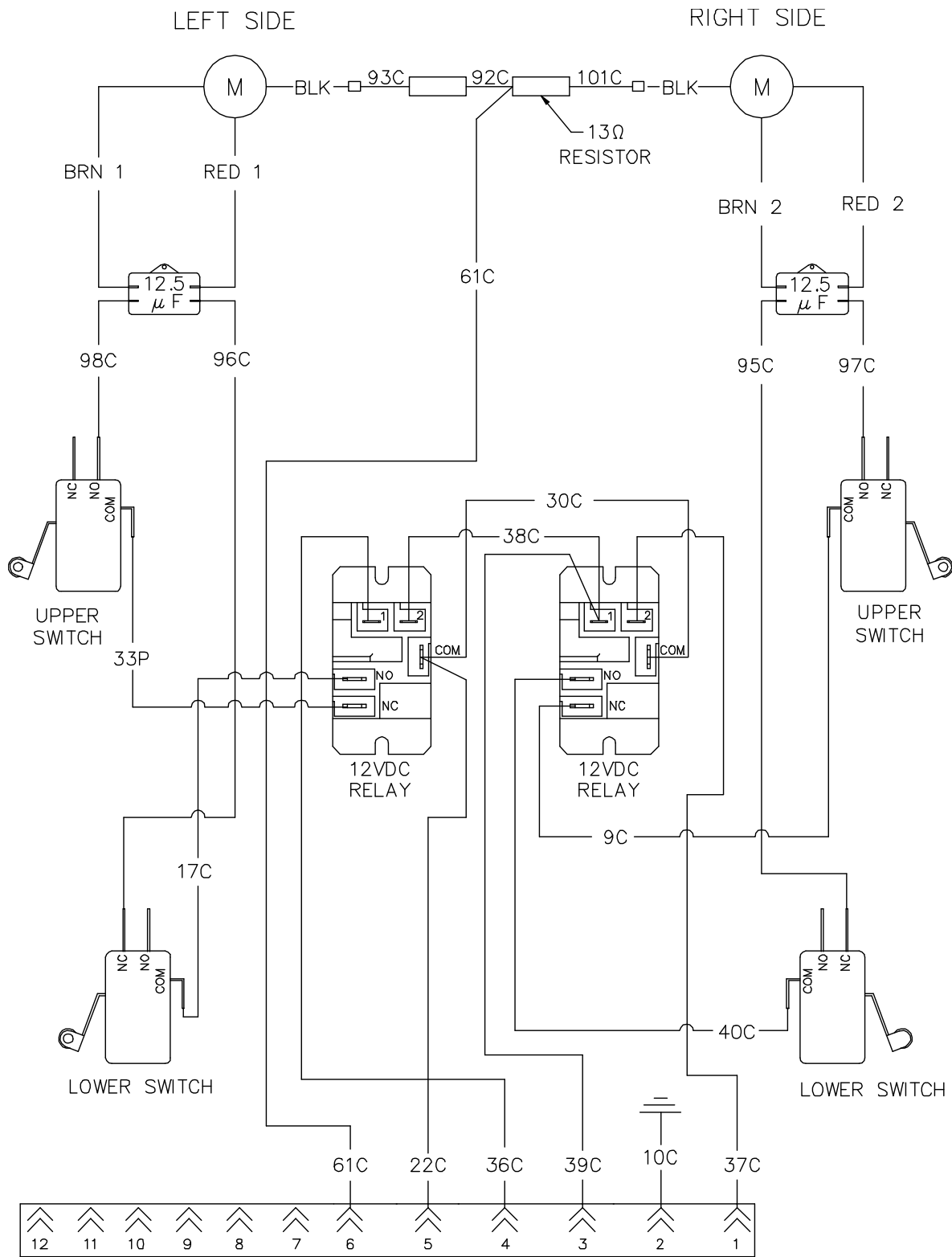

REFERENCES TO LEFT & RIGHT ARE FROM THE REAR OF THE FRYER

8050555E

# 1.9 Modular Basket Lift Wiring Diagram 208-250V

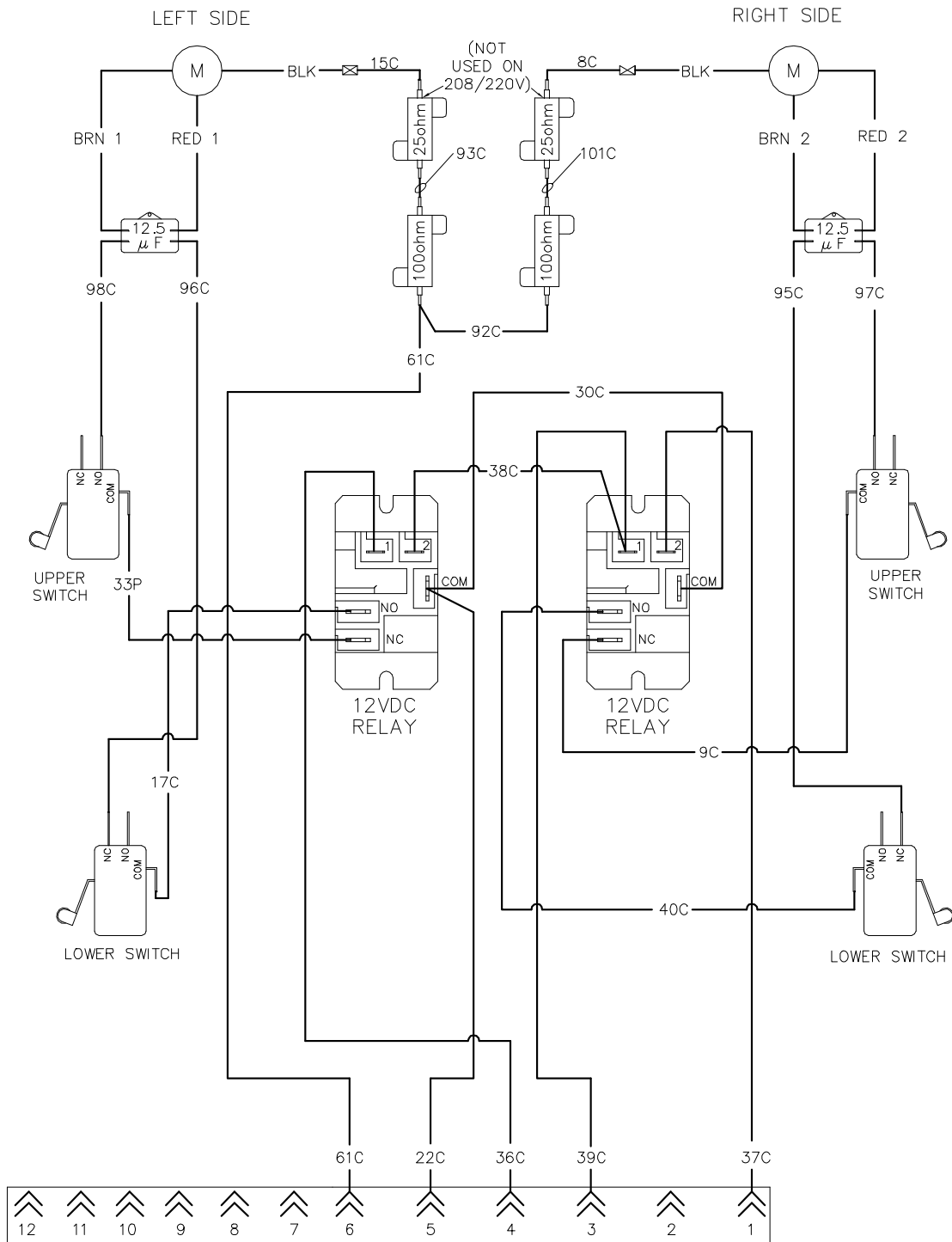





REFERENCES TO LEFT & RIGHT ARE FROM THE REAR OF THE FRYER

8050888D

**WELBILT***Bringing innovation to the table***WWW.WELBILT.COM**

Welbilt provides the world's top chefs, and premier chain operators or growing independents with industry leading equipment and solutions. Our cutting-edge designs and lean manufacturing tactics are powered by deep knowledge, operator insights, and culinary expertise. All of our products are backed by KitchenCare® – our aftermarket, repair, and parts service.

 CLEVELAND  
CONVOTHERM® DELFIELD®  
FITKITCHEN™ FRYMASTER®  
GARLAND KOLPAK®  
LINCOLN MANITOWOC®  
MERCO® MERRYCHEF®  
MULTIPLEX®