



47 Series Gas Fryers

Service & Parts Manual



Frymaster, a member of the Commercial Food Equipment Service Association, recommends using CFESA Certified Technicians.

24-Hour Service Hotline 1-800-551-8633

08/2022



NOTICE

IF, DURING THE WARRANTY PERIOD, THE CUSTOMER USES A PART FOR THIS FRYMASTER DEAN EQUIPMENT OTHER THAN AN UNMODIFIED NEW OR RECYCLED PART PURCHASED DIRECTLY FROM FRYMASTER DEAN, OR ANY OF ITS AUTHORIZED SERVICE CENTERS, AND/OR THE PART BEING USED IS MODIFIED FROM ITS ORIGINAL CONFIGURATION, THIS WARRANTY WILL BE VOID. FURTHER, FRYMASTER DEAN AND ITS AFFILIATES WILL NOT BE LIABLE FOR ANY CLAIMS, DAMAGES OR EXPENSES INCURRED BY THE CUSTOMER WHICH ARISE DIRECTLY OR INDIRECTLY, IN WHOLE OR IN PART, DUE TO THE INSTALLATION OF ANY MODIFIED PART AND/OR PART RECEIVED FROM AN UNAUTHORIZED SERVICE CENTER.

 DANGER

Improper installation, adjustment, alteration, service or maintenance can cause property damage, injury, or death. Read the installation, operating, and service instructions thoroughly before installing or servicing this equipment.

 DANGER

For your safety, do not store or use gasoline or other flammable liquids or vapors in the vicinity of this or any other appliance.

 CAUTION

Instructions explaining procedures to be followed **MUST** be posted in a prominent location in the event the operator detects a gas leak. This information can be obtained from the local gas company or gas supplier.

This equipment is to be installed in compliance with the basic plumbing code of The Building Officials and Code Administrators International, Inc. (BOCA) and the Food Service Sanitation Manual of the Food and Drug Administration.

COMPUTERS

FCC

This device complies with Part 15 of the FCC rules. Operation is subject to the following two conditions:
1) This device may not cause harmful interference, and 2) This device must accept any interference received, including interference that may cause undesired operation. While this device is a verified Class A device, it has been shown to meet the Class B limits.

CANADA

This digital apparatus does not exceed the Class A or B limits for radio noise emissions as set out by the ICES-003 standard of the Canadian Department of Communications.

Cet appareil numerique n'emet pas de bruits radioelectriques depassany les limites de classe A et B prescrites dans la norme NMB-003 edictee par le Ministre des Communcations du Canada.

 **DANGER**

THIS PRODUCT CONTAINS CHEMICALS KNOWN TO THE STATE OF CALIFORNIA TO CAUSE CANCER AND/OR BIRTH DEFECTS OR OTHER REPRODUCTIVE HARM.

Operation, installation, and servicing of this product could expose you to airborne particles of glasswool or ceramic fibers, crystalline silica, and/or carbon monoxide. Inhalation of airborne particles of glasswool or ceramic fibers is known to the State of California to cause cancer. Inhalation of carbon monoxide is known to the State of California to cause birth defects or other reproductive harm.

 **WARNING**

Drawings and photos used in this manual are intended to illustrate operational, cleaning and technical procedures and may not conform to on-site management operational procedures.

 **WARNING**

No structural material on the fryer should be altered or removed to accommodate placement of the fryer under a hood. Questions? Call the Frymaster/Dean Service Hotline at 1-800-551-8633.

 **CAUTION**

The crumb tray in fryers equipped with a filter system must be emptied into a fireproof container at the end of frying operations each day. Some food particles can spontaneously combust if left soaking in certain shortening material. Additional information can be obtained in the filtration manual included with the system.

 **DANGER**

The front ledge of the fryer is not a step. Do not stand on the fryer. Serious injury can result from slips or contact with the hot oil.

 **CAUTION**

Do not bang fry baskets or other utensils on the fryer's joiner strip. The strip is present to seal the joint between the fry vessels. Banging fry baskets on the strip to dislodge shortening will distort the strip, adversely affecting its fit. It is designed for a tight fit and should only be removed for cleaning.

Frymaster fryers equipped with legs are for permanent installation. For moveable or portable installation, Frymaster optional equipment casters **MUST** be used.

QUESTIONS? CALL 1-800-551-8633.

47 SERIES GAS FRYERS

TABLE OF CONTENTS

CHAPTER 1: Service Procedures	1-1
1.1 Functional Description	1-1
Pilot System Configuration	1-1
Electronic Ignition Configuration.....	1-2
Control Options.....	1-3
Interface Boards	1-3
Thermostats.....	1-8
1.2 Accessing Fryers for Servicing	1-8
1.3 Cleaning the Gas Valve Vent Tube	1-9
1.4 Adjusting the Burner Manifold Gas Pressure	1-9
1.5 Adjusting Ceramic Burner Target Spacing and Alignment	1-11
1.6 Adjusting the Pilot Flame	1-11
1.7 Calibrating the Thermostat Control	1-12
1.8 Replacing Fryer Components	1-13
1.8.1 Replacing the Controller or Computer.....	1-13
1.8.2 Replacing the Thermostat.....	1-13
1.8.3 Replacing the Temperature Probe	1-14
1.8.4 Replacing the High-Limit Thermostat in Fryers with Thermostat Controls	1-15
1.8.5 Replacing the High-Limit Thermostat in Fryers with Temperature Probes	1-15
1.8.6 Replacing Control Panel Power Indicator Light in Fryers with Thermostat Controls ...	1-16
1.8.7 Replacing Power or Melt Cycle Switch in Fryers with Thermostat Controls	1-16
1.8.8 Replacing Ceramic Burner Targets.....	1-17
1.8.9 Replacing the Gas Valve.....	1-18
1.8.10 Replacing the Pilot Assembly.....	1-18
1.8.11 Replacing Gas Valve High-Limit Thermostat Wire Adapter	1-19
1.8.12 Replacing the Frypot	1-19
1.9 Troubleshooting and Problem Isolation	1-21
1.9.1 Ignition Failures.....	1-21
1.9.2 Improper Burner Functioning	1-22
1.9.3 Improper Temperature Control.....	1-24
1.9.4 Computer-Related Problems.....	1-25
1.9.5 Filtration Problems	1-26
1.9.6 Leaking.....	1-29
1.9.7 Modular Basket Lift Malfunctions	1-29
1.9.8 Interpretation of Digital Controller Lights.....	1-31
1.10 Troubleshooting Guides	1-32
1.10.1 Initial Troubleshooting	1-32
1.10.2 Troubleshooting the 24 VAC Circuit: Electronic Ignition	1-34
1.10.3 Troubleshooting the 24 VAC Circuit: Non-Electronic Ignition	1-37
1.10.4 Troubleshooting the Temperature Probe	1-39
1.10.5 Probe Resistance Charts	1-40
1.11 Wiring Diagrams	1-40

**47 SERIES GAS FRYERS
TABLE OF CONTENTS**

CHAPTER 2: Parts List	2-1
2.1 Accessories	2-1
2.2 Burner Manifold Assemblies and Component Parts	2-2
2.3 Burner Ignition System Components	2-3
2.4 Gas Valve Assemblies and Connection Components	2-4
2.5 Gas Manifold Assemblies	2-5
2.6 Cabinet Assemblies and Component Parts	2-6
2.6.1 Door Assemblies and Component Parts	2-9
2.7 Component Box/Shield Component Parts	2-10
2.8 Probes, High-Limits and Basket Lift Timers	2-12
2.9 Operating Thermostat and Related Components	2-13
2.10 Computers and Controllers	2-14
2.11 Filter Base Assembly- FootPrint III Series	2-15
2.12 Filter Motors, Pumps and Related Components	2-16
2.13 Filter Pan Assembly- FootPrint III Series	2-18
2.14 Oil Return Manifolds and Related Components	2-19
2.15 Oil Return Valve Assembly	2-20
2.16 Drain Manifold Assembly and Related Components	2-21
2.17 Filter Component Box Assemblies	2-22
2.18 Flue Assemblies and Related Components	2-23
2.19 Frypot Assemblies and Related Components	2-25
2.19.1 Frypot Components: Full-Vat	2-25
2.19.2 Frypot Components: Dual-Vat	2-27
2.20 Power Shower Components	2-29
2.21 Drain Valve Components	2-30
2.21.1 Full-Vat Drain Valve Components	2-30
2.21.1 Dual-Vat Drain Valve Components	2-31
2.22 Modular Basket Lift Components	2-33
2.23 Gas Conversion Kits	2-35

47 SERIES GAS FRYERS

CHAPTER 1: SERVICE PROCEDURES

1.1 Functional Description

47 Series fryers contain a welded stainless steel frypot that is directly heated by gas flames that are diffused evenly over its lower surface by ceramic targets.

In full-vat configurations, the flames originate from orifices in a U-shaped burner manifold positioned beneath the frypot. In dual-vat configurations, the U-shaped manifold is replaced by a pair of J-shaped manifolds, one for each vat. The diameter of the orifices differs for natural and LP gas as indicated in the accompanying table.

47 Series Orifice Sizes		
Gas	Drill Size	Millimeters
Natural	53	1.45
LP	65	0.86

An electromechanical gas valve regulates gas flow to the manifold(s). 47 Series fryers are equipped with a 24-volt valve system. Units with thermostat controls are equipped with a pilot ignition (millivolt) system. Units with other type controllers may be configured with either a pilot ignition (millivolt) system or an electronic ignition system.

Pilot System Configuration

The pilot system is comprised of the pilot orifice, pilot hood, and a thermopile. The pilot serves two purposes. The first is to light the burner, the second is to heat the thermopile. In operation, the thermopile is in contact with the pilot flame and generates millivolts. The millivolt output passes through a normally closed high-limit switch and energizes the gas valve pilot coil, which in turn opens the pilot valve. If the pilot flame is extinguished, voltage is lost to the gas valve pilot coil and the pilot valve closes. The gas valve is constructed so that the main valve will not open if the pilot valve is not open. The pilot flame must be manually lit when the fryer is first placed into operation. A separate 24-volt circuit, activated by the fryer ON/OFF switch, provides voltage through the thermostat or controller to the gas valve main coil, which opens the main valve.

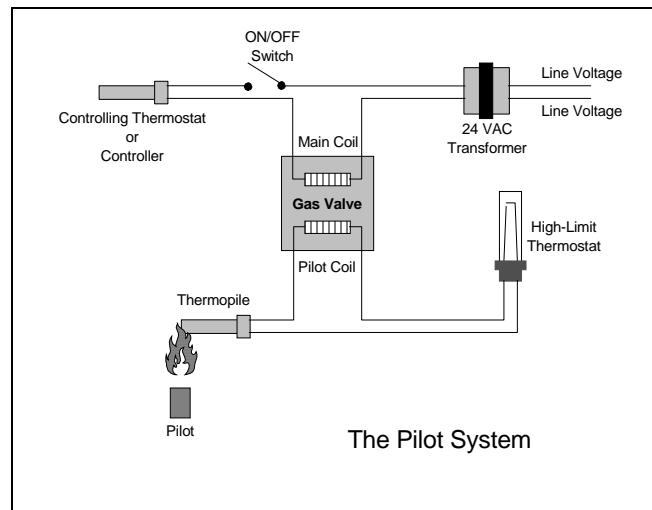

47 SERIES GAS FRYERS CHAPTER 1: SERVICE PROCEDURES

1.1 Functional Description (cont.)

Electronic Ignition Configuration

In units configured for electronic ignition, an ignition module connected to an ignitor assembly replaces the pilot system. The ignition module performs four important functions: it provides fuse protection for the 24-volt circuit, provides an ignition spark, supplies voltage to the gas valve, and proofs the pilot flame.

The module contains a 4-second time delay circuit and a coil that activates the gas valve. The ignitor assembly consists of a spark plug, a pilot, and a flame sensor element.

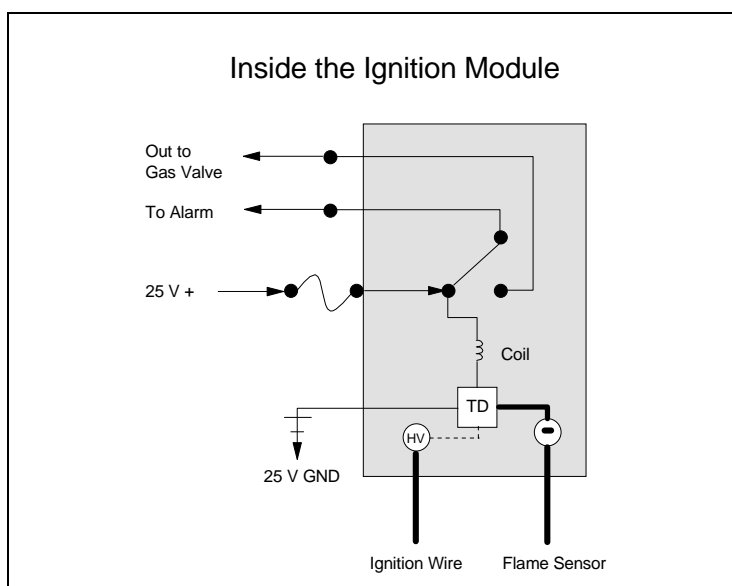

At start-up the ON/OFF switch is placed in the "ON" position, supplying 12 VDC to the heat control circuitry in the controller or computer and to one side of the heat relay coil on the interface board. If resistance in the temperature probe indicates the temperature in the frypot is below 180°F (82°C), the current flows through a melt cycle circuit where a timer switch alternately closes for 3 seconds and opens for 24 seconds. If the temperature is 180°F (82°C) or above, the current flows through a heat circuit, bypassing the timer switch. In either case, current is supplied to the other leg of the heat relay coil which then closes an electronic switch in the 24 VAC circuit to provide current to the ignition module.

Circuitry in the ignition module sends 24 VAC current to the gas valve via a normally closed high-limit switch and a drain safety switch. Simultaneously, the module causes the ignitor to spark for 4 seconds to light the pilot flame. A flame sensor verifies that the pilot is lit by measuring the flow of microamps through the flame. If the pilot does not light (or is extinguished), current to the ignition module is cut, preventing the main valve from opening, and the ignition module "locks out" until the power switch is turned "OFF", then back "ON".

47 SERIES GAS FRYERS

CHAPTER 1: SERVICE PROCEDURES

1.1 Functional Description (cont.)

A temperature probe monitors the temperature in the frypot. When the programmed setpoint temperature is reached, resistance in the probe causes the heat cycle circuitry in the controller to cut off current flow through the heat relay. This in turn cuts off the 24 VAC current to the ignition module, resulting in closure of the gas valve.

Control Options

47 Series fryers may be equipped with thermostat controls, solid-state analog controls, solid-state digital controls, basket lift timers, or Computer Magic III computers.

In fryers equipped with thermostat controls, the fryer and melt cycle are turned on and off by means of rocker switches and the temperature is set by means of a knob connected directly to the frypot-mounted thermostat. These units have no interface board. In this type unit, once started, the melt cycle will continue until it is manually turned off regardless of the temperature in the frypot. Fryers equipped with other types of controllers have an interface board located in the component box (shield) behind the control panel.

Interface Boards

The interface board provides a link between the controller/computer and the fryer's individual components without requiring excessive wiring, and allows the controller to execute commands from one central point. Two types of interface boards may be used in 47 Series fryers; the type used depends on the fryer configuration.

In units configured for electronic ignition, P/N 806-5857 is used; the other board is P/N 106-0386 (or 806-3398 in units built before October 2002). Each type is discussed in detail in the following pages.

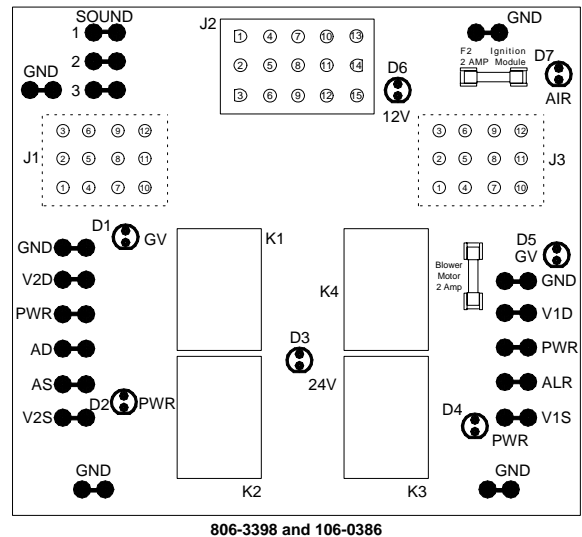
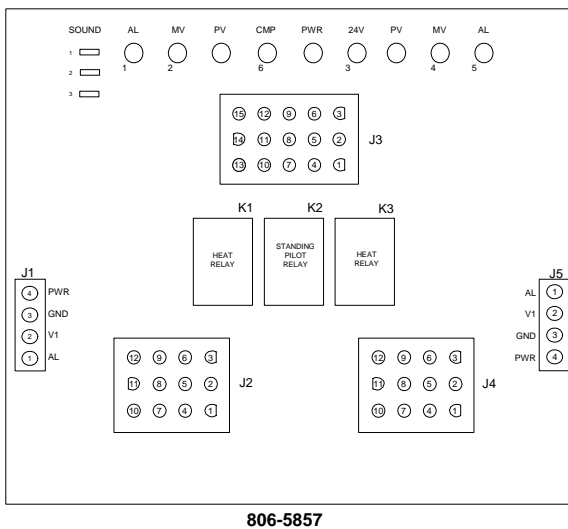

47 SERIES GAS FRYERS CHAPTER 1: SERVICE PROCEDURES

IFB 806-5857: The electronic ignition board contains two types of relays. Heat relays (K1 and K3) operate at 12 VDC output from the controller. They switch 24 VAC to the main gas circuit when the unit calls for heat. The middle relay (K2) switches 24 VAC to the pilot circuit when the unit is powered up. The purpose of this relay is to allow the pilot to remain continuously lit.

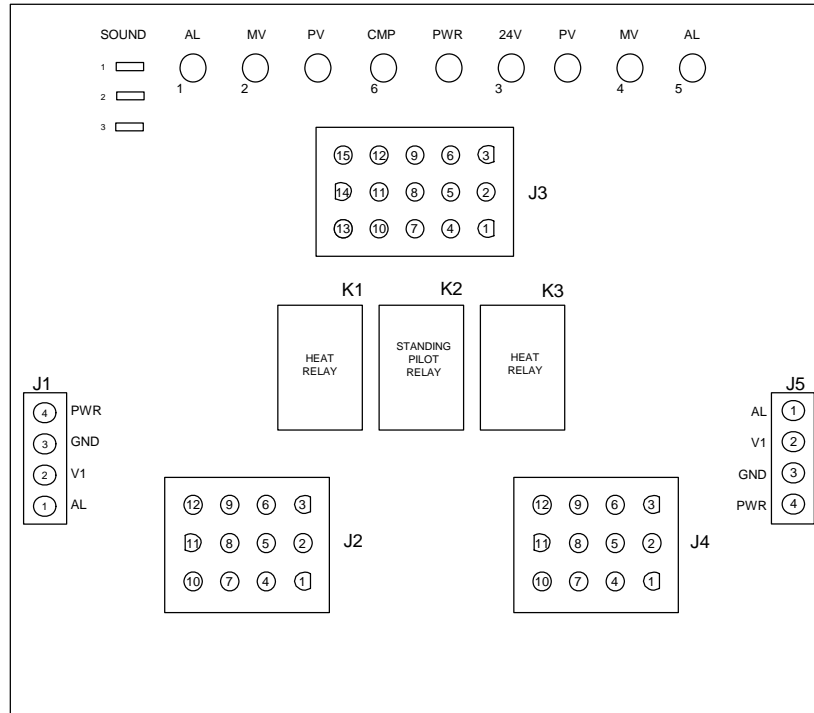

INTERFACE BOARD 806-5857

FREQUENTLY USED TEST POINTS FOR INTERFACE BOARD P/N 806-5857			
Test	Meter Setting	Pins	Test Results
12VAC Power to Controller	50VAC Scale	1 and 3 on J3	12-18
24VAC Power to Right Module	50VAC Scale	4 on J5 and GROUND	22-28
24VAC Power to Left Module	50VAC Scale	4 on J1 and GROUND	22-28
12VDC Power to Right MBL Relay	50VDC Scale	7 on J3 and 9 on J4	12-18
12VDC Power to Left MBL Relay	50VDC Scale	9 on J3 and 6 on J2	12-18
24VAC Power to Right High-Limit	50VAC Scale	12 on J4 and GROUND	22-28
24VAC Power to Left High-Limit	50VAC Scale	3 on J2 and GROUND	22-28
Probe Resistance (Right)*	R x 1000 Ohms	14 on J3 and 10 on J4	**
Probe Resistance (Left)*	R x 1000 Ohms	14 on J3 and 1 on J2	**
High-Limit Continuity (Right)	R x 1 Ohm	12 on J4 and Wire 13C on Gas Valve	0
High-Limit Continuity (Left)	R x 1 Ohm	3 on J2 and Wire 12C on Gas Valve	0
* Disconnect 15-pin harness from controller before testing probe circuit.			
** See Probe Resistance Charts in this chapter.			

47 SERIES GAS FRYERS CHAPTER 1: SERVICE PROCEDURES

The following table identifies the meaning associated with each of the LEDs arranged across the top of the interface board. **NOTE:** In full vat units, ignore the left-side LEDs.

P/N 806-5857 INTERFACE BOARD LED DIAGNOSTIC LIGHTS	
AL	Indicates ignition module lockout
MV	Indicates 24 VAC to main gas valve
PV	Indicates 24 VAC to pilot valve
CMP	Indicates 12 VAC from transformer
24V	Indicates 24 VAC from transformer
PWR	Indicates 24 VAC to ignition module

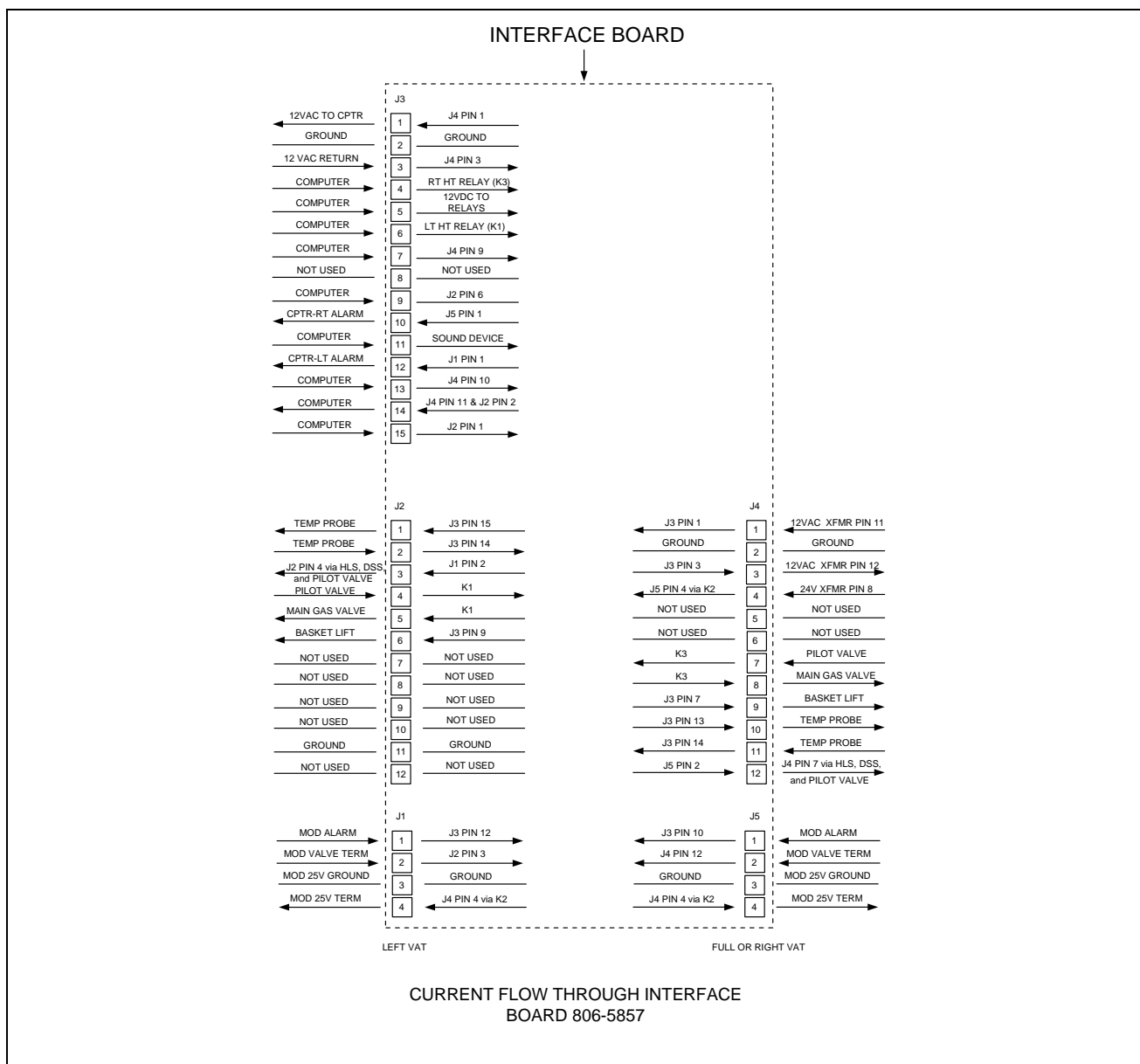

47 SERIES GAS FRYERS CHAPTER 1: SERVICE PROCEDURES

IFBs 806-3398 and 106-0386: The 47 Series of fryers has been in production for many years. Consequently, servicers are likely to encounter three different interface board designs. Although the boards differ slightly in appearance, basic functioning and electrical connections are the same from one to another. In the earlier design 806-3398 interface board (used between June 1996 and July 1999), the diagnostic LEDs are arrayed in a row across the bottom of the board as shown in the left-hand illustration below. In later design 806-3398 interface boards (and in the 106-0396 interface boards that replaced them in current production fryers), the LEDs (labeled D1 through D7) are scattered around the board as shown in the right-hand illustration. The primary difference between the earlier design boards and the later design boards is the combining of the separate blower motor relay (K4) and the heat relays (K1 and K2) into a pair of replaceable relays (K2 and K3) in the latter. Also, the 106-0386 interface board has an additional fuse located in the upper right hand corner. Prior to June 1996, a board with replaceable relays very similar in appearance to the 106-0386 board was used. It is distinguished from the 106-0386 board by the absence of fuses. On full vat units, the relay for the left vat (K1 in early 806-3398 IFBs or K2 in later design 806-3398 and 106-0386 IFBs) is not present. On units with basket lifts, K3 and K5 (early 806-3398) or K1 and K4 are present.

NOTE: Although the printing on many boards indicates 2 Amp fuses, 3 Amp fuses (P/N 807-3843) must be used.

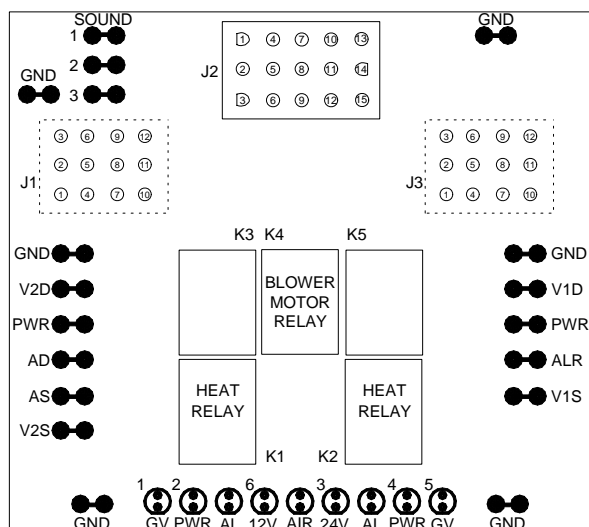

EARLIER DESIGN INTERFACE BOARD P/N 806-3398

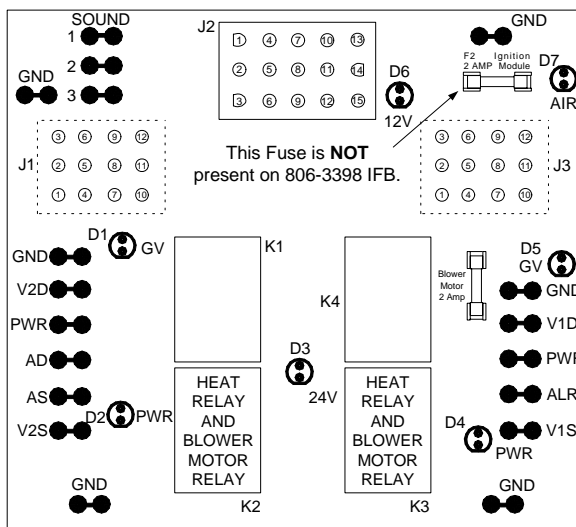

LATER DESIGN INTERFACE BOARDS P/N 806-3398 and 106-0386

These standard interface boards are also used in a number of fryer types besides the 47 Series. **The information contained in this section applies to 47 Series applications ONLY.**

Earlier design 806-3398 boards (used from June 1996 through July 1999) contain two heat relays (K1 and K2) that switch 24VAC to the ignition and gas valve circuits when the computer/controller heat logic circuit calls for heat. Relay K4 switches 120VAC to the blower motor when either K1 or K2 closes. The relays on these boards are soldered on – if one fails, the whole board must be replaced.

The later design 806-3398 (and 106-0386 boards that replaced them in current production fryers) have only two relays. In this design, K2 and K3 are double-pole-double throw (dpdt) relays that supply 24VAC to the ignition and gas valve circuits, as well as 120VAC to the blower motor. The relays on this board plug into sockets. If a relay fails, it can be replaced.

47 SERIES GAS FRYERS CHAPTER 1: SERVICE PROCEDURES

FREQUENTLY USED TEST POINTS FOR INTERFACE BOARDS P/N 806-3398 and 106-0386			
Test	Meter Setting	Pins	Test Results
12VAC Power to Controller	50VAC Scale	1 and 3 on J3	12-18
24VAC Power to Right Module	50VAC Scale	8 on J3 and GROUND	22-28
24VAC Power to Left Module	50VAC Scale	8 on J1 and GROUND	22-28
12VDC Power to Right MBL Relay	50VDC Scale	7 on J2 and 7 or 10 on J3	12-18
12VDC Power to Left MBL Relay	50VDC Scale	9 on J2 and 7 or 10 on J1	12-18
24VAC Power to Right High-Limit	50VAC Scale	9 on J3 and GROUND	22-28
24VAC Power to Left High-Limit	50VAC Scale	9 on J1 and GROUND	22-28
Probe Resistance (Right)*	R x 1000 Ohms	2 on J3 and 6 on J3	**
Probe Resistance (Left)*	R x 1000 Ohms	2 on J1 and 6 on J1	**
High-Limit Continuity (Right)	R x 1 Ohm	9 on J3 and Wire 13C on Gas Valve	0
High-Limit Continuity (Left)	R x 1 Ohm	9 on J1 and Wire 12C on Gas Valve	0
* Disconnect 15-pin harness from controller before testing probe circuit.			
** See Probe Resistance Charts in this chapter.			

47 SERIES GAS FRYERS

CHAPTER 1: SERVICE PROCEDURES

Fryers equipped with Thermostat Controls have an adjustable *controlling thermostat*. The temperature at which the thermostat opens and closes is adjusted by physically changing the setting of the thermostat itself by means of an attached knob. The Fenwal controlling thermostat used in the 47 Series fryers is sensitive to one-degree changes in temperature.

CAUTION

Fenwal thermostats are used in a number of Frymaster products. The thermostat for the 47 Series is 4 inches long. Do not use 3-inch Fenwal thermostats in 47 Series fryers.

Fryers equipped with all other type controls have a *temperature probe*. In this configuration, the probe resistance varies directly with the temperature. That is, as the temperature rises, so does resistance at a rate of approximately 2 ohms for every 1° (°F or °C). Circuitry in the controller monitors the probe resistance and controls burner firing when the resistance exceeds or falls below programmed temperatures (setpoints). The temperatures are programmed by means of a keypad on the face of the controller.

All 47 Series fryers are equipped with a *high-limit thermostat*. In the event that the fryer fails to properly control the oil temperature, the high-limit thermostat prevents the fryer from overheating to the flash point. The high-limit thermostat acts as a normally closed power switch that opens when exposed to temperatures above 425°F to 450°F (218°C to 232°C). The different types of thermostats have different part numbers for CE and Non-CE configured models, and are not interchangeable.

1.2 Accessing Fryers for Servicing

DANGER

Moving a fryer filled with cooking oil/shortening may cause spilling or splattering of the hot liquid. Follow the draining instructions included with the fryer before attempting to relocate a fryer for servicing.

1. Shut off the gas supply to the unit. Unplug the power cords. Disconnect the unit from the gas supply.
2. Remove any attached restraining devices.
3. Relocate the fryer for service accessibility.
4. After servicing is complete, reconnect the unit to the gas supply, reattach restraining devices, and plug in the electrical cords.

1.3 Cleaning the Gas Valve Vent Tube

1. Set the fryer power switch and the gas valve to the "OFF" position.

47 SERIES GAS FRYERS CHAPTER 1: SERVICE PROCEDURES

- Carefully unscrew the vent tube from the gas valve. **NOTE:** The vent tube may be straightened for ease in removal.
- Pass a piece of ordinary binding wire (.052 inch diameter) through the tube to remove any obstruction.
- Remove the wire and blow through the tube to ensure it is clear.
- Reinstall tube and bend so that the opening is pointing downward.

1.4 Adjusting Burner Manifold Gas Pressure

WARNING

This task should be performed by qualified service personnel only.

- Ensure that the gas valve knob is in the "OFF" position.
- Remove the pressure tap plug from the gas valve (see arrows in photos below for location).

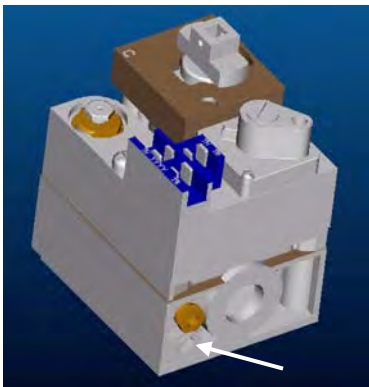

Non-CE Pilot Ignition Valve

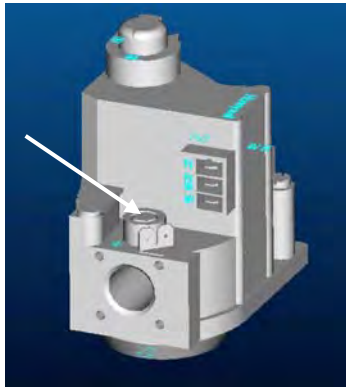

Non-CE Electronic Ignition Valve

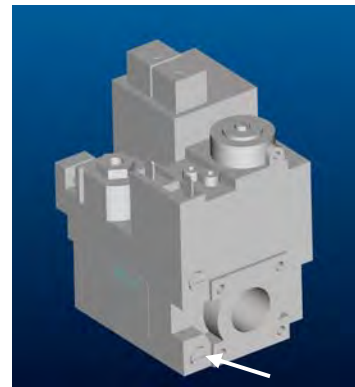

CE Pilot Ignition Valve

- Insert the fitting for a gas pressure-measuring device into the pressure tap hole.
- Place the gas valve in the "ON" position then place the fryer power switch in the "ON" position. When the burner lights and continues to burn, note gas pressure reading for correct pressure in accordance with the accompanying tables.

47 SERIES GAS FRYERS CHAPTER 1: SERVICE PROCEDURES

Non-CE Standard Burner Manifold Gas Pressures	
Gas	Pressure
Natural	3.5" W.C. 0.8 kPa
LP	8.25" W.C. 2.5 kPa

CE Standard Burner Manifold Gas Pressures	
Gas	Pressure (mbar)
Natural Gas Lacq (G20) under 20 mbar	8
Natural Gas Gronique * (G25) under 25 mbar	10
Propane (G31) under 37 or 50 mbar	21

* Belgian G25 = 7,0 mbar

5. To adjust burner gas pressure, remove the cap from the gas valve regulator and adjust to correct pressure.

6. Place the fryer power switch and the gas valve in the "OFF" position. Remove the fitting from the pressure tap hole and reinstall the pressure tap plug.

47 SERIES GAS FRYERS CHAPTER 1: SERVICE PROCEDURES

1.5 Adjusting Ceramic Burner Target Spacing and Alignment

⚠ DANGER

Drain the frypot or remove the handle from the drain valve before proceeding further.

Proper spacing of the top edge of the ceramic burner targets is $\frac{3}{4}$ -inch (13 mm) from the frypot side. To adjust target spacing, bend the brackets to which they are attached away or toward the frypot to the proper distance. (A length of board of the proper thickness is useful as a gauge to verify spacing and alignment.) Proper spacing of the rear ceramic burner target is 1 inch from the frypot back.

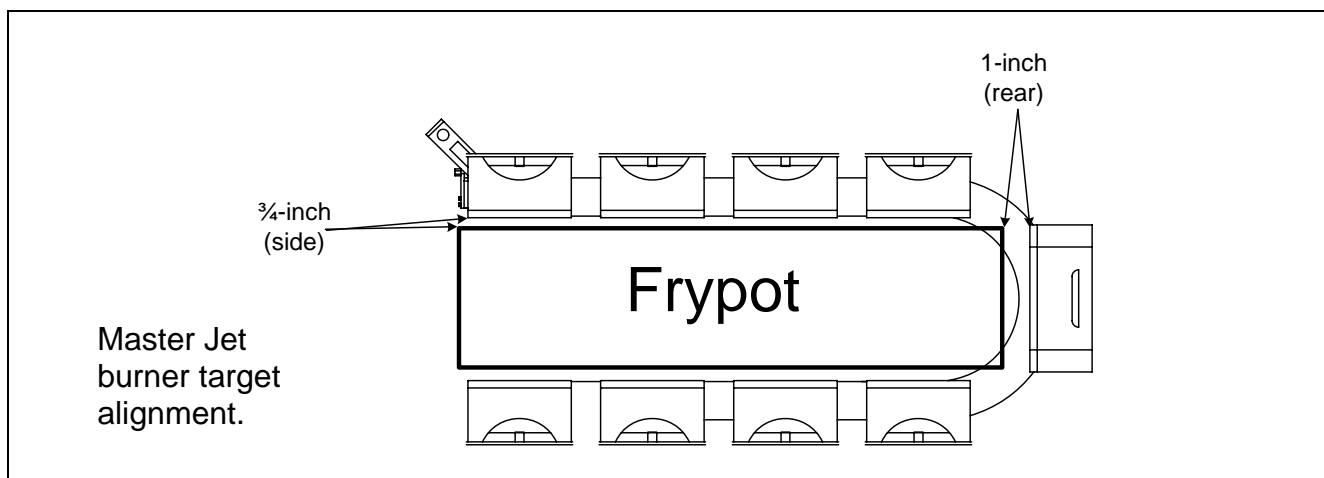

1.6 Adjusting the Pilot Flame

1. Remove the cap from the pilot adjustment screw hole on the gas valve.
2. Using a small, flat-tipped screwdriver, turn the pilot adjusting screw counterclockwise to increase length of flame or clockwise to decrease length of flame. Adjust to obtain a flame from 1 inch to $1\frac{1}{2}$ inches long.
3. Reinstall the pilot adjustment screw cap.

47 SERIES GAS FRYERS
CHAPTER 1: SERVICE PROCEDURES

1.7 Calibrating the Thermostat Control

NOTE: The fryer control panel must be hinged down from the control panel mounting-frame to perform thermostat calibration. In order to hinge the control panel down, the thermostat knob must be removed from its shaft.

1. Fill the frypot to the lower OIL-LEVEL line with cooking oil/shortening. If solid shortening is used, it must be melted before starting the calibration procedure.
2. Ensure the fryer ON/OFF Switch is in the "OFF" position, then light the pilot. (Refer to Chapter 1 for detailed lighting instructions.)
3. Insert a good grade thermometer or pyrometer into the frypot so that it touches the thermostat guard.
4. Disconnect the solid extension shaft from the end of the flexible shaft using an appropriately sized Allen wrench.
5. Remove the flexible shaft from the thermostat shaft screw.
6. Place the fryer ON/OFF switch in the "ON" position.

NOTE: If the burner does not light at this time, it does not mean the thermostat is defective. Recheck the wiring, and then slowly turn the thermostat adjusting screw counterclockwise until the burner lights. Turning the adjusting screw counterclockwise causes the burner to light and clockwise causes it to shut off.

7. When the cooking oil/shortening temperature reaches 325°F (162°C), turn the thermostat adjusting screw slowly **clockwise** until the burner shuts off.
8. Allow the fryer to sit for a few minutes, then slowly turn the thermostat adjusting screw **counterclockwise** until the burner lights.
9. Repeat steps 7 and 8 at least three times to ensure an accurate setting is obtained. The Thermostat Control is considered to be properly calibrated if the burner lights as the cooking oil/shortening cools to 325°F (162°C)—not when the burner shuts off as the temperature rises.
10. Once the calibration point of 325°F (162°C) is determined, allow the burner to cycle on and off at least 3 times to be sure it will light at the calibrated temperature.
11. After the calibration is complete, place the fryer power switch in the "OFF" position and disconnect the fryer from the electrical supply.
12. Carefully install the thermostat flexible extension on the thermostat shaft, ensuring that the setscrews are tight.

**47 SERIES GAS FRYERS
CHAPTER 1: SERVICE PROCEDURES**

1.7 Calibrating the Thermostat Control (cont.)

 **CAUTION**

The thermostat adjusting screw must not be moved while installing the flexible extension shaft.

13. Install the solid metal extension shaft on the end of the flexible shaft with the stop pin at the 12 o'clock position. Ensure the stop pin and setscrews are tight to prevent slippage.
14. Reinstall and secure the fryer control panel. Loosen the temperature dial plate screws and rotate the dial until the 325°F (162°C)-index mark is at the 12 o'clock position, then retighten the screws.
15. Reinstall the thermostat knob with its pointer aligned with the 325°F (162°C)-index mark on the temperature dial plate. Tighten the thermostat knob set screws to prevent slippage.

1.8 Replacing Fryer Components

1.8.1 Replacing the Controller or Computer

1. Disconnect the fryer from the electrical supply.
2. Unscrew the two control panel screws. The control panel is hinged at the bottom and will swing open from the top.
3. Unplug the fryer wiring harness from the back of the controller/computer.
4. Remove the controller/computer by lifting it from the hinge slots in the fryer control panel frame.
5. Reverse the procedure to install a new controller/computer.

1.8.2 Replacing the Thermostat

1. Disconnect the fryer from the electrical supply.
2. Drain cooking oil/shortening below level of probe.
3. Remove thermostat knob. Remove the screws from the upper left and right corners of the control panel. The control panel is hinged at the bottom and will swing open from the top.
4. Disconnect the wiring plug(s) from the component shield/control box.
5. Remove the control panel from the fryer by disengaging its tabs from the hinge slots in the mounting frame.

47 SERIES GAS FRYERS CHAPTER 1: SERVICE PROCEDURES

1.8.2 Replacing the Thermostat (cont.)

6. Remove the solid extension shaft from the end of the flexible shaft using an appropriately sized Allen wrench. Remove the flexible shaft from the thermostat shaft screw.
7. Disconnect leads from terminal block.
8. Unscrew the thermostat from the frypot and remove.
9. Apply Loctite™ PST567 thread sealant or equivalent to the replacement thermostat threads.
10. Reverse steps 1 through 8 to install the replacement.



The Thermostat Control must be calibrated after installation is complete. Refer to Section 1.7 for calibration instructions.

1.8.3 Replacing the Temperature Probe

1. Disconnect the fryer from the electrical supply.
2. Drain cooking oil/shortening below level of probe.
3. Remove the screws from the upper left and right corners of the controller panel. The controller is hinged at the bottom and will swing open from the top.
4. Unplug the wiring harness from the back of the controller and remove the controller from the fryer by disengaging its tabs from the hinge slots in the mounting frame.
5. Remove two screws and nuts from the base of the interface board mounting-bracket.
6. Disconnect the 12-pin plug from the back of the interface board and lay the board in the left end of the compartment with all other wires still connected.
7. Remove the 12-volt transformer from the component shield and lay it in the left end of the compartment with wires still connected.
8. Using a pin-pusher, remove the temperature probe wires from the 12-pin plug disconnected in step 7.
9. Unscrew the temperature probe from the frypot and remove.
10. Apply Loctite™ PST567 thread sealant or equivalent to new probe threads.
11. Reverse steps 1 through 10 to install replacement probe.

47 SERIES GAS FRYERS

CHAPTER 1: SERVICE PROCEDURES

1.8.4 Replacing the High-Limit Thermostat in Fryers with Thermostat Controls

1. Disconnect the fryer from the electrical supply.
2. Drain cooking oil/shortening below the level of the thermostat.
3. Remove the thermostat knob. Remove the screws from the upper left and right corners of the control panel. The control panel is hinged at the bottom and will swing open from the top.
4. Disconnect the wiring plug(s) from the component shield/control box.
5. Remove the control panel from the fryer by disengaging its tabs from the hinge slots in the mounting frame.
6. Remove the molded high-limit thermostat wire adapter from the gas valve pilot coil.
7. Unscrew the high-limit thermostat from the frypot and remove.
8. Apply Loctite™ PST567 thread sealant or equivalent to the replacement thermostat threads.
9. Reverse steps 1 through 7 to install the replacement high-limit thermostat.

1.8.5 Replacing the High-Limit Thermostat in Fryers with Temperature Probes

1. Disconnect the fryer from the electrical supply.
2. Drain cooking oil/shortening below the level of the thermostat.
3. Remove the screws from the upper left and right corners of the controller panel. The controller is hinged at the bottom and will swing open from the top.
4. Unplug the wiring harness from the back of the controller.
5. Remove the controller from the fryer by disengaging its tabs from the hinge slots in the mounting frame.
6. Remove two screws and nuts from the base of the interface board mounting-bracket.
7. Disconnect the 12-pin plug from the back of the interface board and lay board in the left end of compartment with all other wires still connected.
8. Remove the high-limit thermostat wires from the gas valve pilot coil and pull them up through the control shield.
9. Unscrew the high-limit thermostat from the frypot and remove.

47 SERIES GAS FRYERS
CHAPTER 1: SERVICE PROCEDURES

1.8.5 Replacing the High-Limit Thermostat in Fryers with Temperature Probes (cont.)

10. Apply Loctite™ PST567 thread sealant or equivalent to new thermostat threads.
11. Reverse steps 1 through 9 to install the replacement thermostat.

1.8.6 Replacing Control Panel Power Indicator Light in Fryers with Thermostat Control

1. Disconnect the fryer from the electrical supply.
2. Remove the thermostat knob.
3. Remove the screws from the upper left and right corners of the control panel. The control panel is hinged at the bottom and will swing open from the top.
4. Unplug the control panel wiring harness from the component shield/control box.
5. Carefully press the light out of the control panel back side. Remove one wire terminal at a time and connect to the replacement light until all wires are transferred.
6. Carefully press the light back into the control panel back.
7. Reverse steps 1-4 to reassemble fryer.

1.8.7 Replacing Power or Melt Cycle Switch in Fryers with Thermostat Controls

1. Disconnect the fryer from the electrical supply.
2. Remove the thermostat knob.
3. Remove the screws from the upper left and right corners of the control panel. The control panel is hinged at the bottom and will swing open from the top.
4. Unplug the control panel wiring harness from the component shield/control box.
5. Unsnap the chrome bezel from the rear of the switch and push the switch out through the rear of the control panel.
6. Remove wires one at a time from the switch and connect to the replacement switch until all wires are transferred.
7. Reverse steps 1-5 to reassemble fryer.

47 SERIES GAS FRYERS CHAPTER 1: SERVICE PROCEDURES

1.8.8 Replacing Ceramic Burner Targets



Drain the frypot or remove the handle from the drain valve before proceeding further.

1. Disconnect fryer from electrical and gas supplies.
2. Disconnect the wires from the gas valve terminal block, marking each wire to facilitate reconnections.
3. Remove the high-limit thermostat wires from the gas valve pilot coil.
4. Remove the pipe union collar at the left side of the gas valve.
5. Remove the burner heat shield hanger screws at the front of the burner and remove the heat shield.
6. Remove the burner hanger screws.
7. Lower the front of the main burner and pull it forward to clear the rear burner hanger. Lower the burner to the floor.
8. Raise the fryer enough to slide the burner from under the fryer cabinet.
9. To replace only the ceramic targets, straighten the target locking tabs with a pair of needle nose pliers or a screwdriver, and slide the target up and off the bracket. Slide the replacement target onto the bracket and bend the locking tabs down.

To replace the entire target assembly, using a ½-inch box end wrench, remove the two brass orifices that hold the assembly to the burner manifold, replace the assembly, and replace the orifices.



Use extreme care to prevent cross-threading and stripping when reinstalling the brass orifices.

10. Reverse steps 1-8 to reinstall the burner assembly. Check spacing and alignment of targets in accordance with Section 1.5.

47 SERIES GAS FRYERS CHAPTER 1: SERVICE PROCEDURES

1.8.9 Replacing the Gas Valve



Drain the frypot or remove the handle from the drain valve before proceeding further.

1. Disconnect fryer from electrical and gas supplies.
2. Disconnect the wires from the gas valve terminal block, marking each wire to facilitate reconnections.
3. Remove the high-limit thermostat wire from the gas valve pilot coil.
4. Remove the pilot gas line fitting from the gas valve.
5. Remove the pipe union collars to the left and right of the gas valve and remove the valve.
6. Remove the pipefitting from the old gas valve and install on the replacement valve, using Loctite™ PST567 or equivalent pipe thread sealant on threads.
7. Reverse steps 1-5 to install the replacement gas valve.

1.8.10 Replacing the Pilot Assembly



Drain the frypot or remove the handle from the drain valve before proceeding further.

1. Remove the burner assembly in accordance with Section 1.7.9.
2. Remove the pilot tubing from the bottom of the pilot assembly.
3. Bend the clip at the bottom of the pilot assembly and remove the pilot. Disconnect the pilot fitting from the gas valve pilot coil.
4. Remove the two pilot mounting screws from the pilot mounting-bracket and remove the pilot.
5. Reverse the procedure to replace the pilot assembly.

47 SERIES GAS FRYERS CHAPTER 1: SERVICE PROCEDURES

1.8.11 Replacing Gas Valve High-Limit Thermostat Wire Adapter

1. Remove the pilot electrical fitting from the gas valve pilot coil.
2. Lift the molded plastic wire adapter assembly and wires out of the pilot coil.
3. Cut the in-line splices from the wire adapter and high-limit thermostat wires.
4. Strip the wire insulation from the end of the high-limit thermostat wires and splice on a new high-limit thermostat wire adapter assembly.
5. Insert the new molded plastic wire adapter into the gas valve pilot coil.
6. Screw the pilot electrical fitting into the gas valve pilot-coil finger tight, and then 1/8-turn more with a wrench.

1.8.12 Replacing the Frypot

1. Drain cooking oil/shortening from the frypot.
2. Remove all accessories, e.g., frypot covers, basket lift arms, etc. from the fryer.
3. Disconnect the fryer from gas and electrical supplies.
4. Remove the screws from the top cap above the control panel and lift it up and off the fryer(s).
5. If the fryer is equipped with other than a Thermostat Control, skip to Step 10.
6. Remove the thermostat knob. Remove the screws from the upper left and right corners of the control panel. Disconnect the control panel from the fryer wiring harness and remove it from the fryer.
7. Remove the thermostat flexible shaft from the thermostat shaft adjusting screw.
8. Remove the two screws and nuts from the thermostat shaft bracket and lift the thermostat flexible shaft and bracket out of the component box.
9. Disconnect both wires from the gas valve and the 20-hole terminal block. Skip to Step 14.
10. For fryers equipped with other than thermostat controls, remove the screws from the upper left and right corners of the control panel. Disconnect the controller from the fryer wiring harness and remove it from the fryer.
11. Remove the two screws and nuts from the base of the interface board bracket.
12. Disconnect the 12-pin plug from the back of the interface board and remove the temperature probe and high-limit thermostat wires from the plug using a pin pusher.

47 SERIES GAS FRYERS
CHAPTER 1: SERVICE PROCEDURES

1.8.12 Replacing the Frypot (cont.)

13. Lay the interface board and bracket on top of the control shield with wires still connected.
14. Remove the louvered frame above the control panel opening.
15. Remove screws and nuts securing the component box to the fryer.
16. Disconnect wires from components in component box and mark to facilitate reconnection.
17. Remove pilot generator fitting from gas valve pilot coil and lift the high-limit thermostat wire adapter from the slot. Pull the high-limit thermostat wires and adapter up through the grommet at the rear of the box.
18. Remove the wires from the gas valve terminal block. Mark each wire to facilitate reconnection.
19. For fryers equipped with Thermostat Controls, remove the thermostat wire from the gas valve and pull it up through the grommet at the rear of the box. Disconnect the other thermostat wire from the 20-hole terminal block. Mark each wire to facilitate reconnection.
20. Remove the cover from the safety drain switch, disconnect the wires from the switch, and pull them out of the switch box.
21. Pull up and forward on the component box to clear the rear-mounting stud on the front of the frypot.
22. Remove the component box from the fryer by rotating its right side up and to the left.
23. Remove the pipe union from the right side of the gas valve.
24. Remove the section of square drain from the drain valve of the frypot to be removed.
25. Remove the frypot hold down bracket.
26. Remove the screws from the flue cap sides and back and lift it clear of the fryer(s).
27. Remove the oil return hose or line from the front of the frypot to be removed.
28. Lift the frypot complete with burner, gas valve, flue, and drain valve from the fryer cabinet.
29. Transfer burner heat shield and burner to replacement frypot.
30. Remove drain valve, thermostat or temperature probe, and high-limit thermostat and install on replacement frypot.
31. Reverse steps 1-28 to reassemble fryer.

47 SERIES GAS FRYERS CHAPTER 1: SERVICE PROCEDURES

CAUTION

Before installing thermostat/temperature probe, high-limit thermostat, and drain valve on replacement frypot, clean their threads and apply Loctite™ PST567 thread sealant or equivalent to the threads.

1.9 Troubleshooting and Problem Isolation

This section is intended to provide technicians with a general knowledge of the broad problem categories associated with this equipment, and the probable causes of each. With this knowledge, the technician should be able to isolate and correct any problem encountered.

Problems you are likely to encounter can be grouped into seven broad categories:

1. Ignition failures
2. Improper burner functioning
3. Improper temperature control
4. Computer-related problems
5. Filtration problems
6. Leakage problems
7. Modular basket lift malfunctions.

The probable causes of each category are discussed in the following sections. Troubleshooting guides are included in **Section 1.10** to assist in identifying some of the more common problems.

1.9.1 Ignition Failures

Ignition failure occurs when the ignition module fails to sense a flame within the 4-second time delay period and locks out. When this happens, the module sends 24 VAC through the interface board alarm circuit to the controller/computer.

Solid-state controllers indicate ignition failure by illuminating the heat light and trouble light simultaneously. Computer Magic III controls display "**HELP**".

There are three primary reasons for ignition failure, listed in order of probability:

1. Problems related to the gas and/or electrical power supplies.
2. Problems related to the electronic circuits.
3. Problems related to the gas valve.

47 SERIES GAS FRYERS CHAPTER 1: SERVICE PROCEDURES

Problems Related to the Gas and/or Electrical Power Supplies

The main indicators of this are that an entire battery of fryers fails to light and/or there are no indicator lights illuminated on the fryer experiencing ignition failure. Verify that the quick disconnect hose is properly connected, the fryer is plugged in, the main gas supply valve is open, and the circuit breaker for the fryer electrical supply is not tripped.

Problems Related to the Electronic Circuits

If gas and electrical power are being supplied to the fryer, the next most likely cause of ignition failure is a problem in the 24 VAC circuit of fryers equipped with electronic ignition systems, or in the pilot system for those without electronic ignition. If the fryer is equipped with a FootPrint III filtration system, first verify that the drain valve is fully closed. (The valve is attached to a microswitch that must be closed for power to reach the gas valve. Often, although the valve handle appears to be in the closed position, the microswitch is still open.) If the valve is fully closed, or the fryer does not have a filtration system, refer to the troubleshooting guides in this chapter.

Problems Related to the Gas Valve

If the problem is not in the 24 VAC circuit or pilot system, it is most likely in the gas valve itself, but before replacing the gas valve refer to the troubleshooting guides in this chapter.

1.9.2 Improper Burner Functioning

With problems in this category, the burner ignites but exhibits abnormal characteristics such as "popping", incomplete lighting of burner, fluctuating flame intensity, and flames "rolling" out of the fryer.

"Popping" indicates delayed ignition. In this condition, the main gas valve is opening but the burner is not immediately lighting. When ignition does take place, the excess gas "explodes" into flame, rather than smoothly igniting.

The primary causes of popping are:

- Incorrect or fluctuating gas pressure
- Misdirected or weak pilot flame
- Burner deflector targets out of alignment or missing
- Clogged burner orifices
- Inadequate make-up air
- Heat damage to the controller or ignition module
- A cracked ignitor or broken ignition wire
- A defective ignition module

47 SERIES GAS FRYERS

CHAPTER 1: SERVICE PROCEDURES

1.9.2 Improper Burner Functioning (cont.)

If popping occurs only during peak operating hours, the problem may be incorrect or fluctuating gas pressure. Verify that the incoming gas pressure (pressure to the gas valve) is in accordance with the appropriate CE or Non-CE Standard found in Section 1.3 of this manual, and that the pressure remains constant throughout all hours of usage. Refer to **Check Burner Manifold Pressure** in Section 1.4 if burner manifold pressure is suspected of being incorrect.

If popping is consistent during all hours of operation, verify that the pilot is properly positioned above the burner orifice and that the pilot pressure is correct. Correct pilot pressure is indicated by a flame 1 to 1½" long. Refer to Section 1.6 for adjustment procedure.

Clogged burner orifices, especially those near the pilot, are also likely causes of delayed ignition. Clogged orifices are indicated by no flame, flames that are orange-colored, and flames that shoot out at an angle from the rest.

Another cause of popping is an insufficient air supply or drafts that are blowing the pilot flame away from the burner. Check for "negative pressure" conditions in the kitchen area. If air is flowing into the kitchen area, this indicates that more air is being exhausted than is being replenished and the burners may be starved for air.

If the fryer's gas and air supplies are okay, the problem most likely is with one of the electrical components. Examine the ignition module for signs of melting/distortion and/or discoloration due to excessive heat build-up in the fryer. (This condition usually indicates improper flue performance.). Also, examine the controller for the same conditions. A melted or distorted ignition module is automatically suspect and should be replaced, but unless the condition causing excessive heat in the fryer is corrected, the problem is likely to recur.

Next, check to ensure the ignition wire is tightly connected at both ends and examine it for obvious signs of damage. Again, if damage is due to excessive heat in the fryer, that problem must also be corrected.

Check for proper operation by disconnecting the wire from the ignitor (spark plug), inserting the tip of a screw driver into the terminal, and holding it near the frame of the fryer as the power switch is placed in the "ON" position. A strong, blue spark should be generated for at least 4 seconds.

 **DANGER**

MAKE SURE YOU ARE HOLDING THE INSULATED HANDLE OF THE SCREWDRIVER AND NOT THE BLADE. THE SPARKING CHARGE IS APPROXIMATELY 25,000 VOLTS.

Examine the ignitor (spark plug) for any signs of cracking. A cracked ignitor must be replaced.

The *burner lighting on one side only* may be caused by a missing or misaligned rear deflector target or improper burner manifold pressure. Clogged burner orifices are usually the cause of *gaps in burner firing*.

47 SERIES GAS FRYERS

CHAPTER 1: SERVICE PROCEDURES

1.9.2 Improper Burner Functioning (cont.)

Fluctuating flame intensity is normally caused by either improper or fluctuating incoming gas pressure, but may also be the result of variations in the kitchen atmosphere. Verify incoming gas pressure in the same way as for "popping", discussed in the preceding paragraphs. Variations in the kitchen atmosphere are usually caused by air conditioning and/or ventilation units starting and stopping during the day. As air conditioning/ventilation units start and stop, the pressure in the kitchen may change from positive or neutral to negative, or vice versa. Changes in airflow patterns that may affect flame intensity are caused by these variations.

Flames "rolling" out of the fryer are usually an indication of negative pressure in the kitchen. Air is being sucked out of the fryer enclosure and the flames are literally following the air. If negative pressure is not the cause, check for high burner-manifold gas pressure in accordance with the procedures in Section 1.4. An obstructed flue, which prevents the fryer from properly exhausting, may also be the cause.

An *excessively noisy burner*, especially with *flames visible above the flue opening*, may indicate that the burner gas pressure is too high, or it may simply be that the gas valve vent-tube is blocked. If the gas pressure is correct and the vent-tube is unobstructed, the gas valve regulator is probably defective.

Occasionally a burner may apparently be operating correctly, but nevertheless the fryer has a *slow recovery rate* [the length of time required for the fryer to increase the oil temperature from 250°F to 300°F (121°C to 149°C)]. Primary causes are low burner-manifold pressure and/or misaligned or missing deflector targets. If both of these causes are ruled out, the probable cause is a misadjusted gas-valve regulator. Refer to the **Check Burner Manifold Pressure** procedure in Section 1.4 if gas-valve regulator is suspected of being out of adjustment.

1.9.3 Improper Temperature Control

Temperature control, including the melt cycle, is a function of several interrelated components, each of which must operate correctly. The principal component is the thermostat (in thermostat control units) or the temperature probe (in fryers equipped with other types of controllers). Depending upon the specific configuration of the fryer, other components may include the interface board, the controller itself, and the ignition module.

Improper temperature control problems can be categorized into melt cycle problems and failure to control at setpoint problems.

Melt Cycle Problems

In fryers equipped with thermostat controls, a mechanical timer controls the melt cycle. There are three components that may fail, thus disabling the melt cycle. The melt-cycle timer itself, the melt-cycle timer microswitch, or the control panel melt-cycle ON/OFF switch. In all cases, the defective component must be replaced.

47 SERIES GAS FRYERS

CHAPTER 1: SERVICE PROCEDURES

1.9.3 Improper Temperature Control (cont.)

In fryers equipped with other types of controllers, the problem may be with the controller itself, the temperature probe, or a malfunctioning heat relay on the interface board.

For problem isolation techniques, refer to the troubleshooting guides in this chapter.

Failure to Control at Setpoint

In fryers equipped with thermostat controls, the problem will be with the thermostat itself. Possible causes are that the thermostat is out of calibration, the knob or flexible shaft is loose on the thermostat adjusting screw, a thermostat wire is disconnected, or the thermostat is defective. Refer to Section 1.7 for instructions on calibrating the thermostat.

In fryers equipped with other types of controls, the problem may be with the temperature probe, the interface board, or the controller. Refer to the troubleshooting guides in this chapter.

1.9.4 Computer-Related Problems

Computer Magic III Features

Sensitivity or "*Stretch and Shrink Time*"

Sensitivity or stretch time is a programmable feature that increases or decreases the cook time countdown based on variations in the oil temperature from the setpoint.

The sensitivity for each product button has 10 settings (0 through 9). A "0" sensitivity setting will disable the feature (no change in cooking time), while a nine will provide the highest sensitivity or most change. The correct sensitivity for any product is based on the product, its density, the setpoint temperature, and the customer's own requirements.

Recovery Time or "*Rate of Rise*"

Recovery time or rate of rise is a method of measuring a fryer's performance. Put simply, it is the time required for the fryer to increase the oil temperature from 250°F to 300°F (121°C to 149°C). This range is used as a standard since ambient kitchen temperatures can effect the test if lower ranges are used.

The Computer Magic III performs the recovery test each day as the fryer warms up. An operator can view the results of the test any time the fryer is above the 300°F (149°C) point by pressing the button and entering the code 1652. The test results will be displayed in the computer's LED panel in minutes and seconds. The acceptable recovery time for the 47 Series of fryers is 2 minutes.

47 SERIES GAS FRYERS CHAPTER 1: SERVICE PROCEDURES

Common Computer Complaints

Most problems concerning computers have to do with programming them. There are four common complaints. The complaints, their causes, and corrective actions are:

1. Fryer constantly displays "**HI**".

Cause: Setpoint incorrect or missing.

Corrective Action: Press 1 6 5 0, enter the correct setpoint using keypad, then press to lock in the setpoint.

2. Temperature is displayed in Celsius.

Cause: Computer is programmed to display in Celsius.

Corrective Action: Press 1 6 5 8.

3. Temperature is constantly displayed.

Cause: Computer is programmed for constant temperature display.

Corrective Action: Press 1 6 5 L.

4. Computer times down too slowly or too quickly.

Cause: Computer is compensating for oil temperature via the sensitivity setting.

Corrective Action: Reprogram sensitivity setting for each product in accordance with programming instructions in the 47 Series Installation & Operation manual.

1.9.5 Filtration Problems

The majority of filtration problems arise from operator error. One of the most common errors is placing the filter paper on the bottom of the filter pan rather than over the filter screen.

Whenever the complaint is "the pump is running, but no oil is being filtered", check the installation of the filter paper, including that the correct size is being used. While you are checking the filter paper, verify that the O-ring on the bottom of the filter pan is present and in good condition. A missing or worn O-ring will allow the pump to suck air and decrease its efficiency.

If the pump motor overheats, its thermal overload will trip and the motor will not start until it is reset. If the pump motor does not start, press the red reset switch located on the rear of the motor. If the pump then starts, something caused the motor to overheat. It may be just that several frypots were being filtered one after the other and the pump got hot. Letting the pump cool down for at least a half-hour is all that is required in this case. More often, the pump overheated for one of the following reasons:

47 SERIES GAS FRYERS CHAPTER 1: SERVICE PROCEDURES

1.9.5 Filtration Problems (cont.)

- Shortening was solidified in the pan or filter lines.
- The operator attempted to filter oil or shortening that was not heated. Cold oil and shortening are thicker and cause the pump motor to work harder and overheat.

If the motor runs but the pump does not, there is a blockage in the pump. Incorrectly sized or installed paper will allow food particles and sediment to pass through the filter pan and into the pump. When sediment enters the pump, the gears can bind up causing the motor to overload, again tripping the thermal overload. Solidified shortening in the pump will also cause it to seize, with the same result.

A pump seized by debris or hard shortening can usually be freed by manually moving the gears with a screwdriver or other instrument.

1. Disconnect power to the filter system.
2. Remove the input plumbing from the pump.
3. Use a screwdriver to manually turn the gears
 - Turning the pump gears backwards will release a hard particle and allow its removal.
 - Turning the pump gears forward will push softer objects and solid shortening through the pump and allow free movement of the gears.

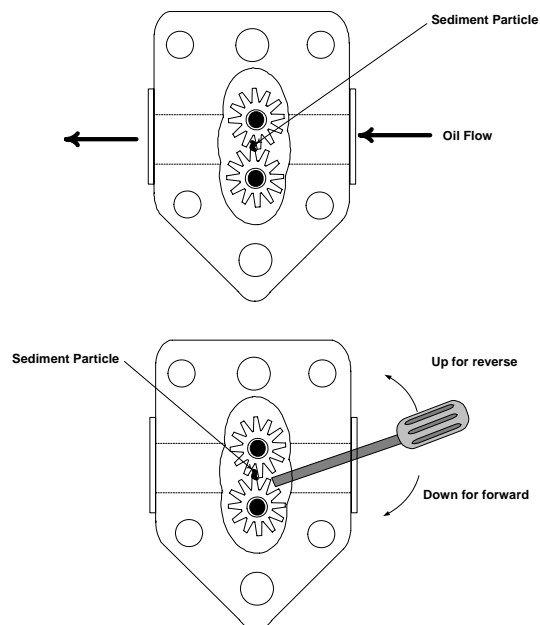

Unclogging a filter pump.

Incorrectly sized or installed paper will also allow food particles and sediment to pass through and clog the suction tube on the bottom of the filter carriage. Particles large enough to block the suction tube may indicate that the crumb tray is not being used.

Pan blockage can also occur if shortening is left in the pan and allowed to solidify. The heater strip on the suction tube is designed to prevent solidification of residual shortening left in the tube. It will not melt or prevent solidification of shortening in the pan.

47 SERIES GAS FRYERS CHAPTER 1: SERVICE PROCEDURES

1.9.5 Filtration Problems (cont.)

Blockage removal can be accomplished by forcing the item out with an auger or drain snake. Compressed air or other pressurized gases should not be used to force out the blockage.

Possible problems with the Power Shower include clogged openings, shortening solidified in the tubes, missing clean-out plugs, and missing or worn O-rings. Cleaning the unit and replacing missing plugs and missing or worn O-rings will correct these problems.

The electronics of the FootPrint III Filter are simple and straightforward. Microswitches, attached to handles for each vat and wired in parallel, provide the 24 VAC required to activate the pump relay coil when the handles are moved to the ON position. The activated pump relay coil pulls in the pump motor switch, supplying power to the pump motor.

The suction tube heater and flexible hose heater are wired directly into the 120 VAC source. They remain energized as long as the unit is plugged in.

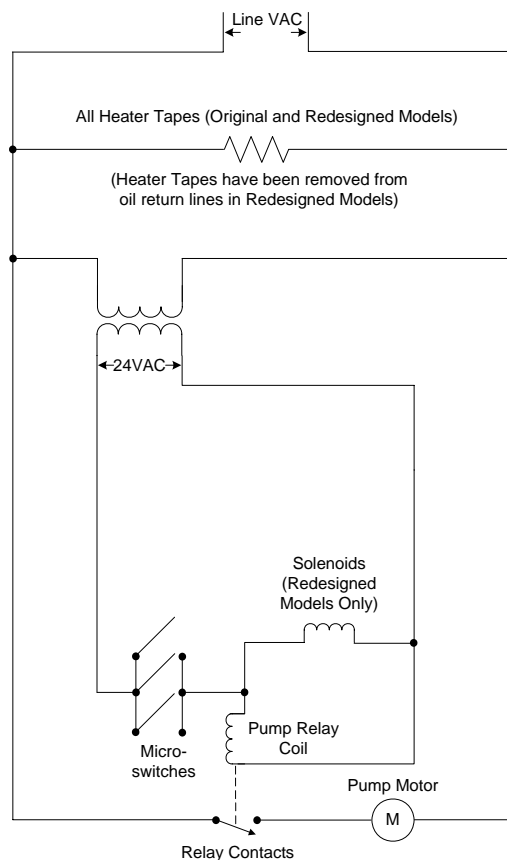

FootPrint III Simplified Wiring Diagram

47 SERIES GAS FRYERS

CHAPTER 1: SERVICE PROCEDURES

1.9.6 Leaking

Frypot leaking will almost always be due to improperly sealed high-limit thermostats, operating thermostats, temperature probes, and drain fittings. When installed or replaced, each of these components must be sealed with Loctite™ PST567 sealant or equivalent to prevent leakage. In very rare cases, a leak may develop along one of the welded edges of the frypot. When this occurs, the frypot must be replaced.

If the sides and/or ends of the frypot are coated with oil/shortening, the most likely cause is spillage over the top of the frypot rather than leakage.

The clamps, which hold the drain tube sections together, may loosen over time as the tubes expand and contract with heating and cooling during use. If the section of drain tube connected to the drain valve is removed for whatever reason, make sure that its grommet is in good condition and properly fitted around the nipple of the drain when it is reinstalled. Also, ensure the drain tube runs downward from the drain along its whole length and has no low points where oil or shortening may accumulate.

1.9.7 Modular Basket Lift Malfunctions

47 Series fryers may optionally be equipped with automatic basket lifts to ensure uniform cooking times. The lifts may be configured for manual control or for control via a Basket Lift Timer or Computer Magic III computer. Basket lifts come in pairs, although each operates independently.

A lift consists of a notched rod to which the basket lift arm is attached, a reversible-drive gear motor, and a pair of roller-activated microswitches. The gear motor engages the notches in the rod, moving it up or down depending upon the direction of rotation of the motor. Microswitches at the upper and lower limits of movement stop the motor when the basket is in the full up or full down position. In units configured for manual (push-button) controls, a mechanical timer controls voltage to the system. A rotary knob is turned to set the cook time, and pressing the button in the middle of the knob activates the motor by applying power through the lower microswitch. The motor drives the basket lift down. As the rod moves downward, it closes the upper microswitch, preparing the motor to run in the opposite direction when the cooking time has expired. When the rod contacts the lower microswitch, power to the motor is interrupted and the motor stops.

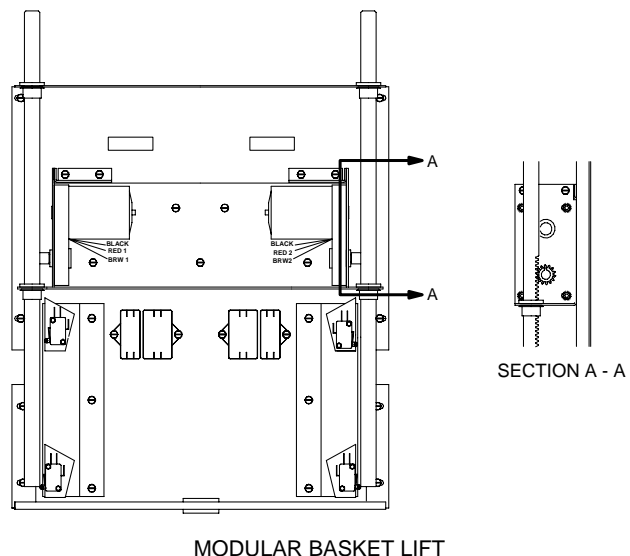

47 SERIES GAS FRYERS CHAPTER 1: SERVICE PROCEDURES

1.9.7 Modular Basket Lift Malfunctions (cont.)

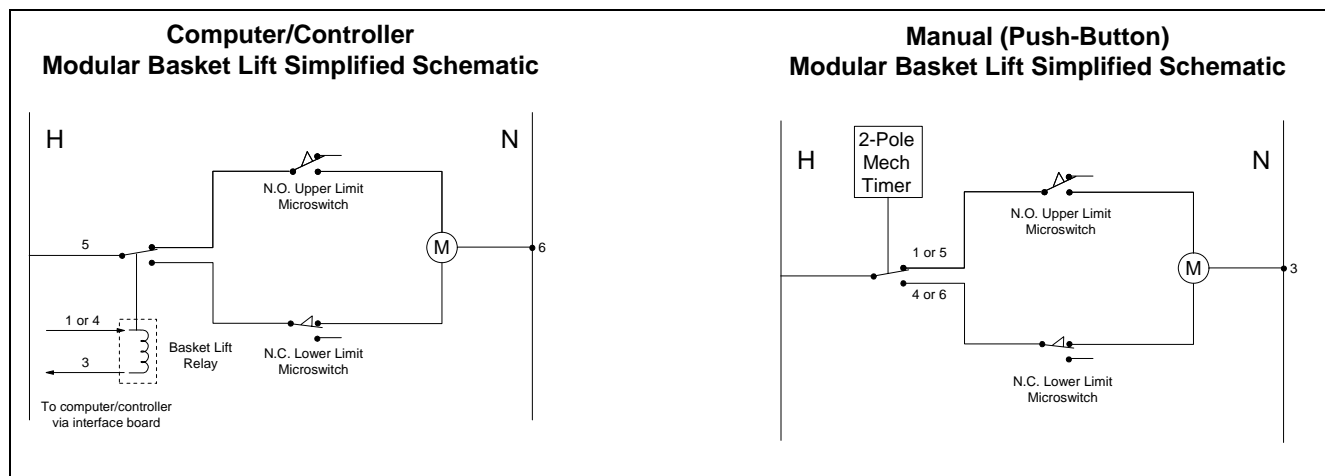

When the timer *times out*, power is supplied to the opposite pole of the motor, through the upper microswitch. The motor drives the rod upward until it loses contact with the upper microswitch, cutting power to the motor and stopping the lift.

In units configured for Basket Lift Timer Controllers or Computer Magic III computers, the process is almost identical. The difference is that the push button mechanical timer is replaced with timing circuitry in the computer or controller. The operator programs specific cook times (and other settings) into the computer/controller. When the product button is pressed, the timing circuitry activates a coil in the basket lift relay to supply power to the lower microswitch. As with the manually controlled units, the microswitch stops the motor at the lift's upper and lower travel limits and reverses the direction of current flow thus reversing the motor direction.

Problems with the basket lift system can be grouped into three categories:

- Binding/jamming problems
- Motor and gear problems
- Electronics problems

Binding/Jamming Problems

Noisy, jerky or erratic movement of the lifts is usually due to lack of lubrication of the rods and their bushings. Apply a light coat of Lubriplate™ or similar lightweight white grease to the rod and bushings to correct the problem.

Another possible cause of binding is improper positioning of the motor, which prevents the gear from correctly engaging the teeth in the rod. To correct the problem, loosen the screws that hold the motor in place and move it forward or backward until the rod has just enough slack to be rotated slightly.

47 SERIES GAS FRYERS CHAPTER 1: SERVICE PROCEDURES

1.9.7 Modular Basket Lift Malfunctions (cont.)

Motor and Gear Problems

The most likely problem to be encountered in this category is erratic motion of the lift due to a worn drive gear. Failure to keep the lift rod and bushings properly lubricated will cause unnecessary wear of the gear. The problem is corrected by replacing the worn gear.

If the lift cycles correctly but fails to remain in the up position (i.e., goes up, but then slowly settles back down into the frypot), the problem is a failed motor brake. A failed motor brake cannot be repaired and requires replacement of the motor itself.

If power is reaching the motor but the motor fails to run, the motor is burned out and must be replaced.

Electronic Problems

This category encompasses problems with the relays, microswitches, capacitors, resistors, interface board, wiring, and controls.

Troubleshooting the electronics of the modular basket lift is simply a process of verifying current flow through the individual components up to and including the motor. Using a multimeter set to the 250 VAC range, check the connections on both sides of the component for the presence of 120 VAC. The simplified wiring diagrams on the preceding pages identify the components and wiring connection points.

1.9.8 Interpretation of Digital Controller Lights

Power light on, heat light cycling, trouble light off, and melt light on:

If fryer oil temperature is below 180°F (82°C), the lights indicate the unit is operating normally.

- If the oil temperature is above 180°F (82°C) and the heat light continues to cycle as if in the melt cycle, this may indicate a defective probe circuit or low incoming 12VAC to the controller.

Power light on, heat light on, trouble light off, and melt light off:

- If the fryer oil temperature is above 180°F (82°C) and below the setpoint temperature, the lights indicate the unit is operating properly.
- If the oil temperature is above the temperature set on the control knob and the heat light remains lit, this may indicate a defective probe circuit.

47 SERIES GAS FRYERS CHAPTER 1: SERVICE PROCEDURES

1.9.8 Interpretation of Digital Controller Lights (cont.)

Power light on, heat light off, trouble light on, and melt light off:

- If the fryer oil temperature is below 410°F (210°C), the lights indicate one of the following:
 - a. The probe circuit is defective, or
 - b. There is a connection problem on pins 2 or 10 on the 15-pin wiring harness.
- If the fryer oil temperature is above 410°F (210°C), the lights indicate a run-away heating circuit.

1.10 Troubleshooting Guides

The following troubleshooting guides are intended to assist service technicians in quickly isolating the probable causes of equipment malfunctions by following a logical, step-by-step process.

1.10.1 Initial Troubleshooting

PROBLEM	PROBABLE CAUSES	CORRECTIVE ACTION
Burner won't ignite. Light in ON/OFF switch is not illuminated.	A. ON/OFF switch is off.	A. Turn ON/OFF switch on.
ON/OFF switch is on, but the switch light is not illuminated.	A. No 24 VAC output from transformer.	A. Check 24VAC circuit. Replace transformer if defective.
ON/OFF switch is on and the switch light is illuminated, but there is no output to gas valve.	A. Drain microswitch circuit (filter-equipped units) is open.	A. Ensure drain valve is fully closed and microswitch is functioning. Replace microswitch if defective.
	B. 24VAC is present at ON/OFF switch, but continuity of the switch in ON position is not "0".	B. ON/OFF switch is defective. Replace switch with a known working switch.
	C. Continuity of thermostat is not "0" (cooking oil/shortening temperature is at least 15°F below thermostat setting).	C. Thermostat is defective. Replace with a known working thermostat.
	D. Gas valve is suspect.	D. Go to burner troubleshooting.

**47 SERIES GAS FRYERS
CHAPTER 1: SERVICE PROCEDURES**

1.10.1 Initial Troubleshooting (cont.)

PROBLEM	PROBABLE CAUSES	CORRECTIVE ACTION
No burner flame.	A. Pilot does not stay lit (fryer is on and thermopile output is approximately 400 millivolts.	A. Check high-limit switch. Switch continuity should be "0". If not, high-limit switch is defective. Replace high-limit switch.
	B. Pilot does not stay lit (fryer is on and thermopile output is not approximately 400 millivolts.	B. Inspect thermopile (units without interface board) and replace if defective.
	C. Pilot stays lit, and the high-limit and thermopile are known working, but burners fail to light.	C. Inspect gas valve and replace if defective.
	D. Gas valve is known to be good, but there is not 24 VAC at the gas valve terminals.	D. Inspect thermostat body (while still in frypot) for damage. Remove and replace thermostat if bent, dented or cracked. Inspect leads for fraying, burning, breaks and/or kinks. If found, remove and replace thermostat. Remove leads from terminal block, allow oil to cool 15°F below thermostat setting and check continuity. If continuity is not "0", then thermostat has failed. Replace thermostat.
	E. Continuity from terminal block to gas valve thermostat wire is not "0".	E. Inspect wiring for breaks or shorts and repair if necessary.
Fluctuating or erratic lighting of burner flame.	A. Incoming gas supply pressures are not within range [Natural- 6-14" W.C. (1.49-3.49 kPa); Propane- 11-14" W.C. (2.74-3.49 kPa)]	A. Inspect gas supply to fryer. Repair and/or replace faulty components (defective supply shut-off valves, incorrect piping size, etc.)
	B. Air in gas supply lines (new installation).	B. Allow unit to cycle on and off for approximately 30 minutes to force air from gas manifold and lines.
	C. Missing or poor target alignment.	C. Replace missing target(s) and/or ensure correct target alignment.
Thermostat will not adjust to correct temperature.	A. Thermostat is out of calibration.	A. Calibrate thermostat. Replace thermostat if calibration is not possible.

47 SERIES GAS FRYERS

CHAPTER 1: SERVICE PROCEDURES

1.10.2 Troubleshooting the 24 VAC Circuit: Electronic Ignition Units

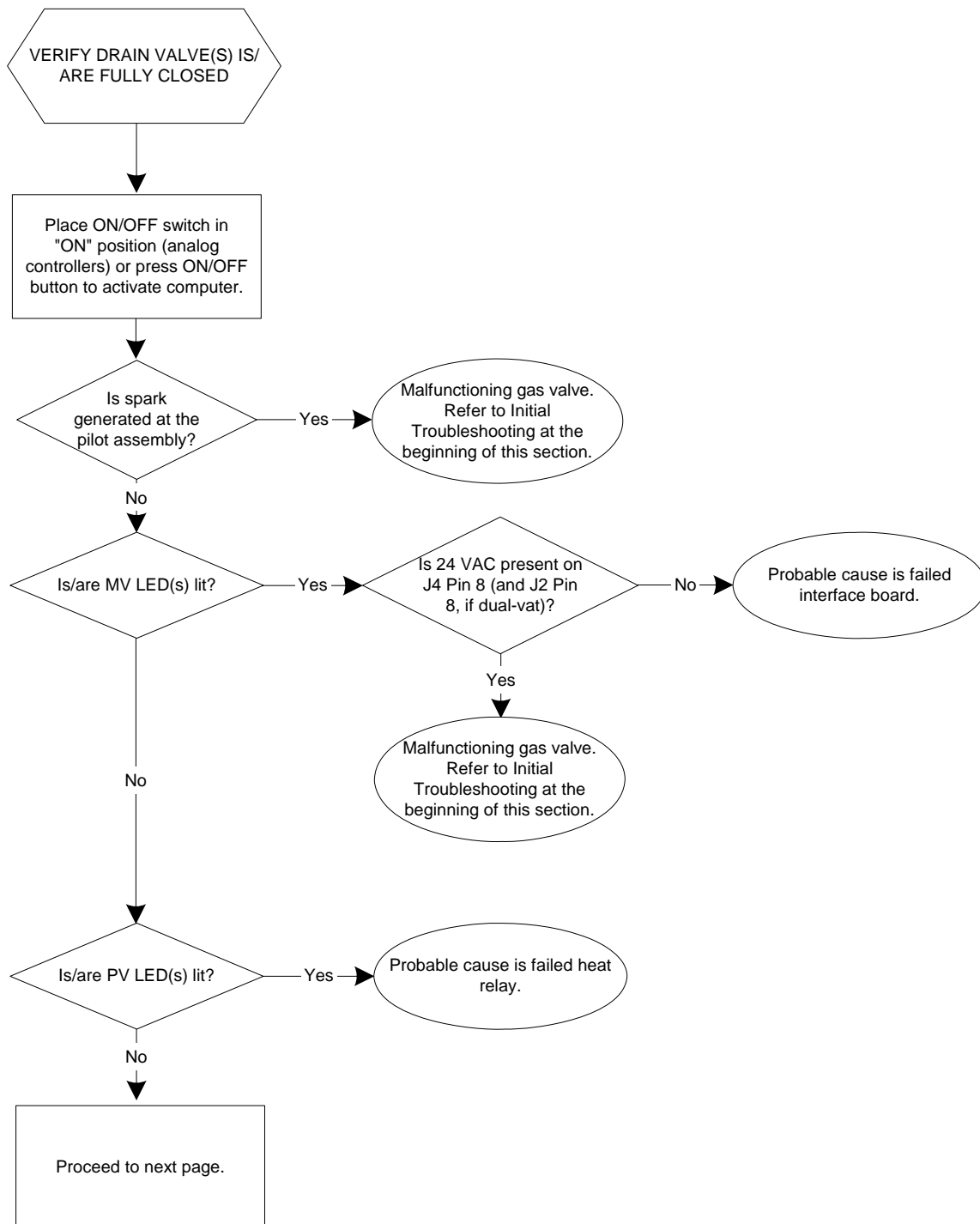

47 SERIES GAS FRYERS

CHAPTER 1: SERVICE PROCEDURES

1.10.2 Troubleshooting the 24 VAC Circuit: Electronic Ignition Units (cont.)

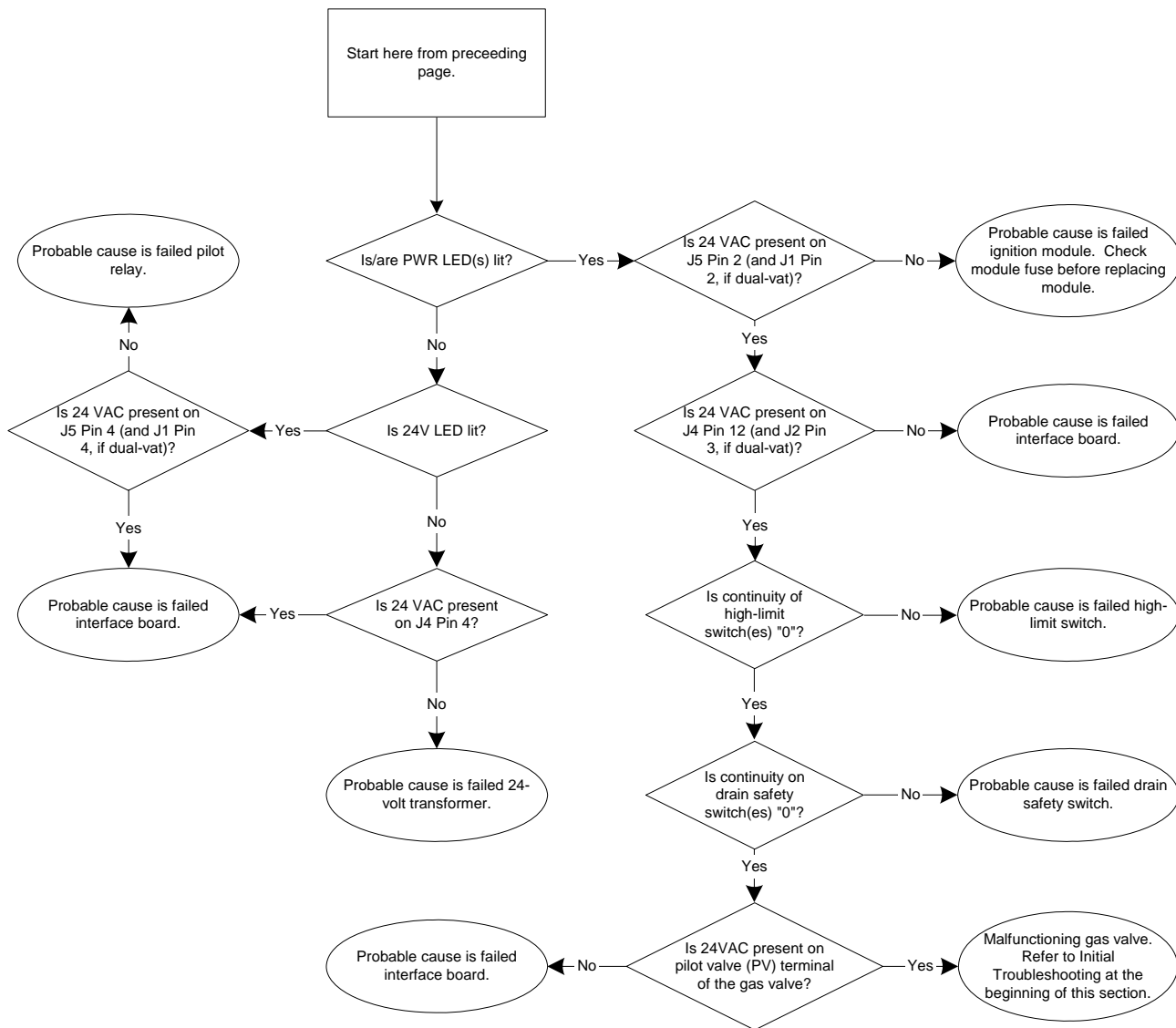

47 SERIES GAS FRYERS CHAPTER 1: SERVICE PROCEDURES

1.10.2 Troubleshooting the 24 VAC Circuit: Electronic Ignition Units (cont.)

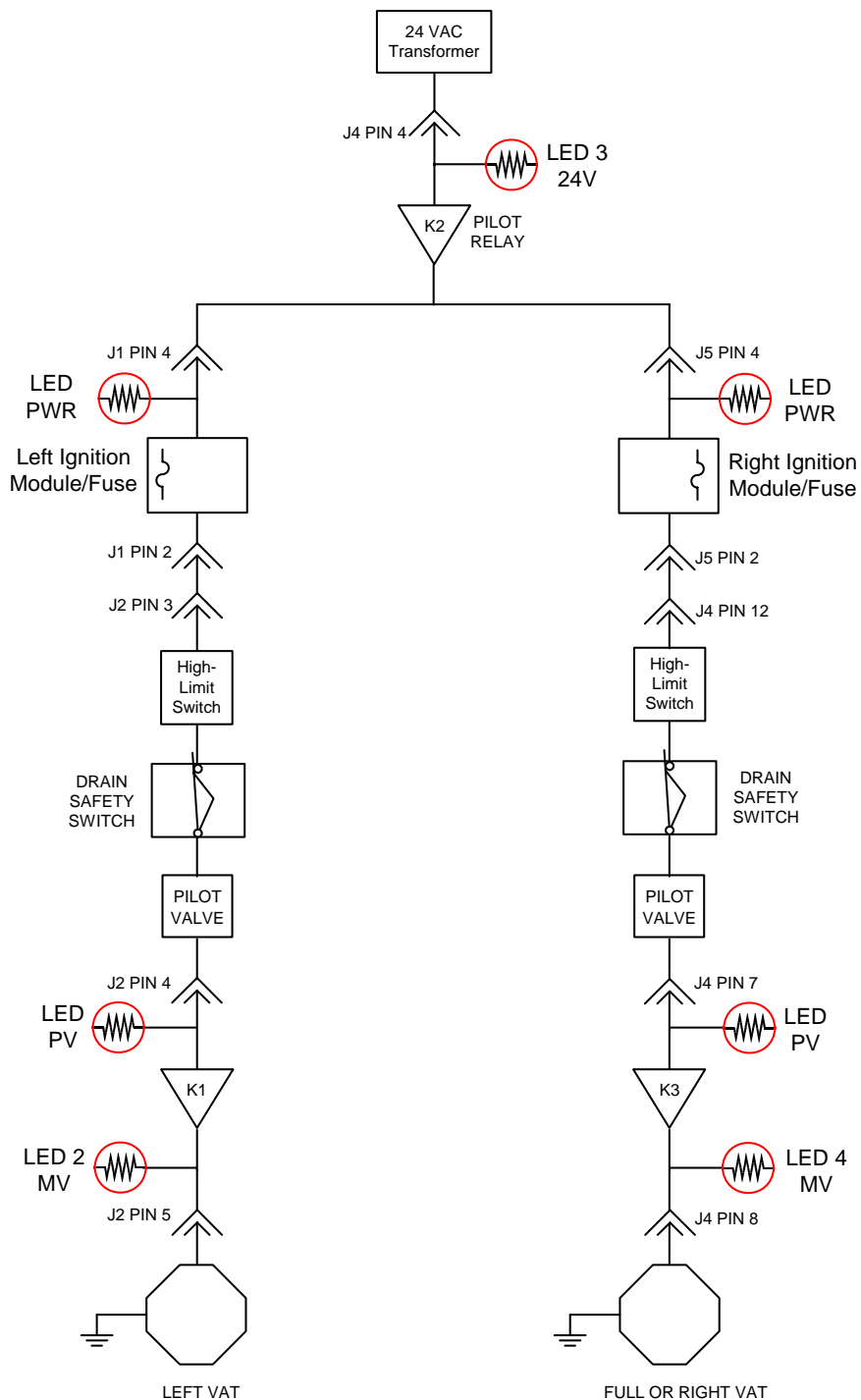

**24 VOLT CIRCUIT
FOR ELECTRONIC IGNITION UNITS
(IFB 806-5857)**

47 SERIES GAS FRYERS

CHAPTER 1: SERVICE PROCEDURES

1.10.3 Troubleshooting the 24 VAC Circuit: Non-Electronic Ignition Units (With Computer Controls)



**47 SERIES GAS FRYERS
CHAPTER 1: SERVICE PROCEDURES**

**1.10.3 Troubleshooting the 24 VAC Circuit: Non-Electronic Ignition Units
(With Computer Controls- cont.)**

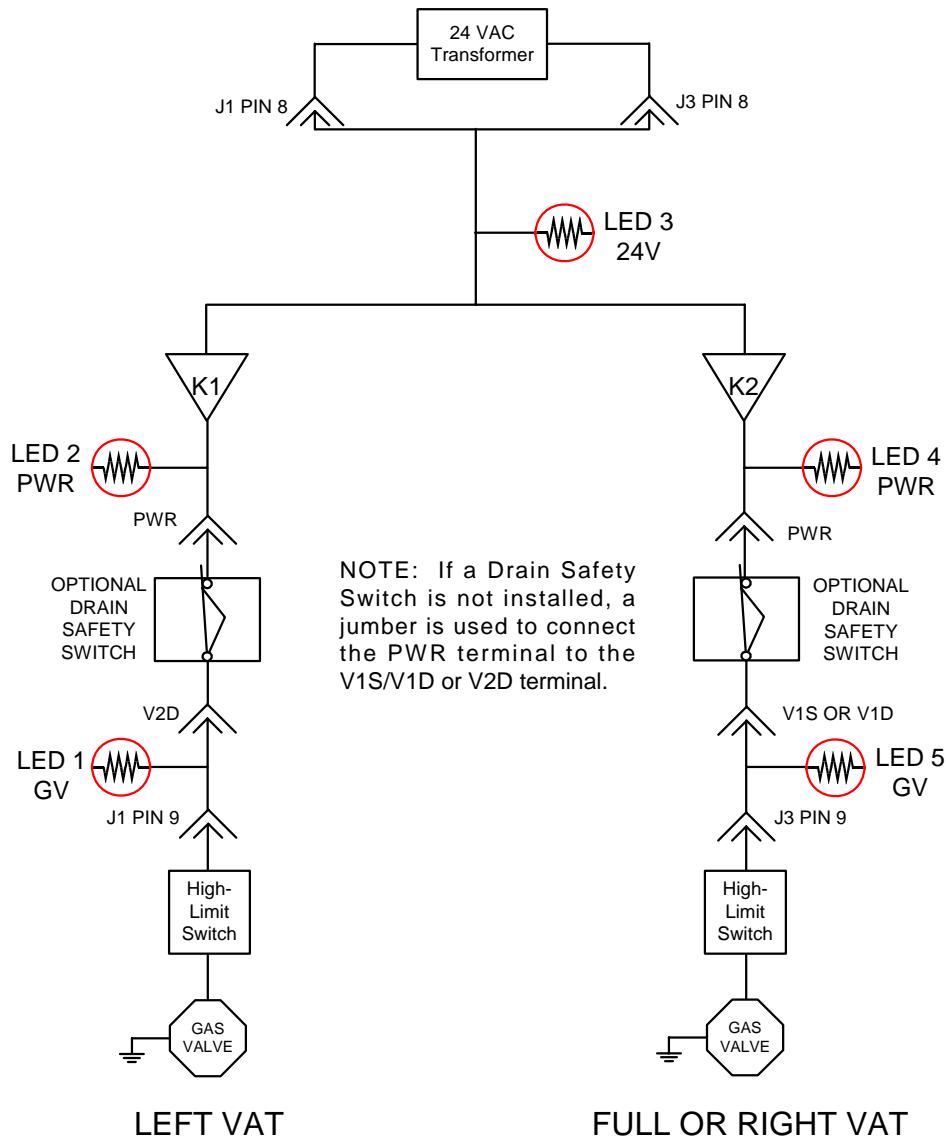

**24 VOLT CIRCUIT
FOR NON-ELECTRONIC IGNITION UNITS
(IFB 806-3398)**

47 SERIES GAS FRYERS

CHAPTER 1: SERVICE PROCEDURES

1.10.4 Troubleshooting the Temperature Probe (With Computer Controls)

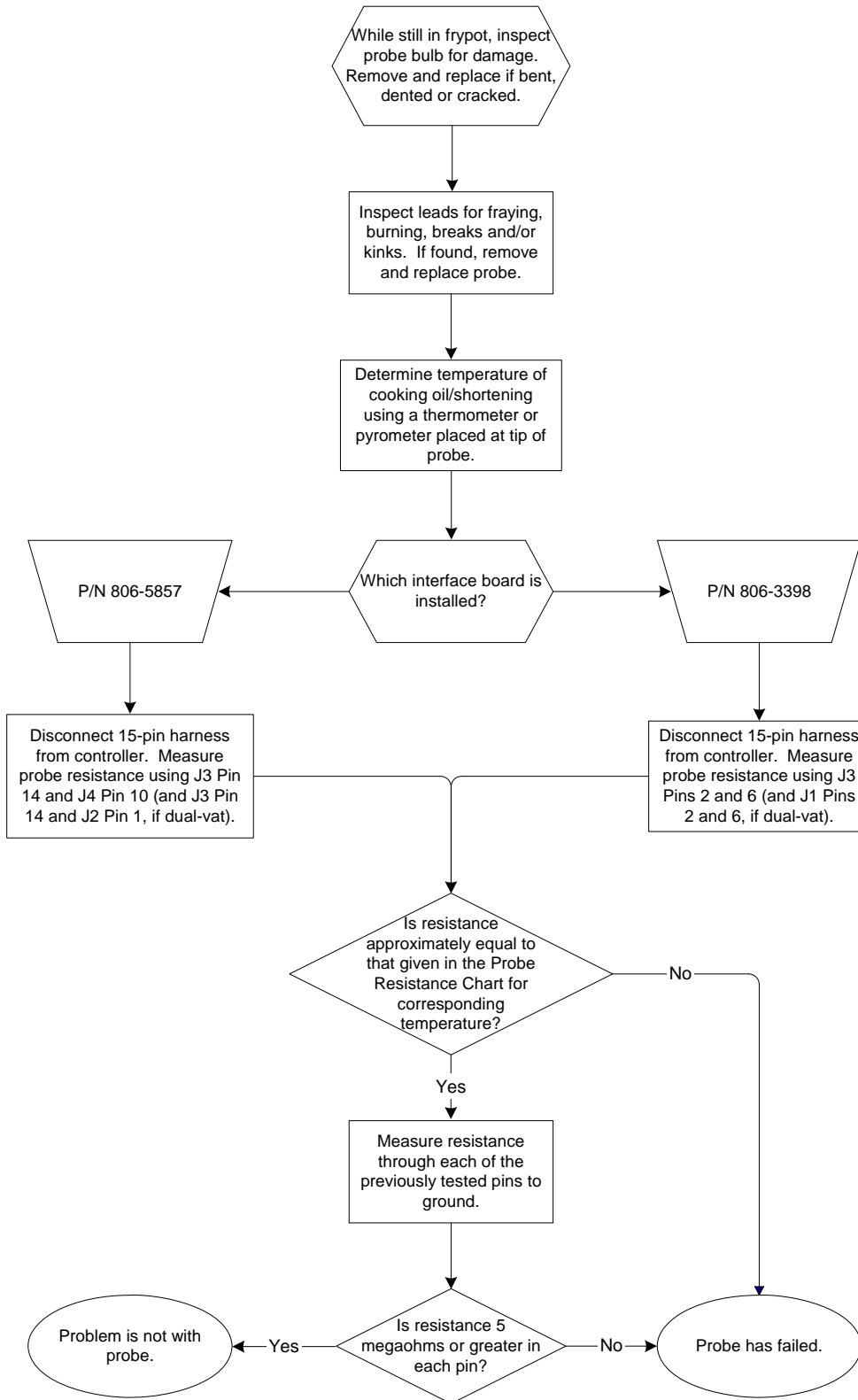

**47 SERIES GAS FRYERS
CHAPTER 1: SERVICE PROCEDURES**

1.10.5 Probe Resistance Chart

Probe Resistance Chart																	
<i>For use with H50 Series fryers manufactured with Minco Thermistor probes only.</i>																	
F	OHMS	C	F	OHMS	C	F	OHMS	C	F	OHMS	C	F	OHMS	C	F	OHMS	C
60	1059	16	130	1204	54	200	1350	93	270	1493	132	340	1634	171			
65	1070	18	135	1216	57	205	1361	96	275	1503	135	345	1644	174			
70	1080	21	140	1226	60	210	1371	99	280	1514	138	350	1654	177			
75	1091	24	145	1237	63	215	1381	102	285	1524	141	355	1664	179			
80	1101	27	150	1247	66	220	1391	104	290	1534	143	360	1674	182			
85	1112	29	155	1258	68	225	1402	107	295	1544	146	365	1684	185			
90	1122	32	160	1268	71	230	1412	110	300	1554	149	370	1694	188			
95	1133	35	165	1278	74	235	1422	113	305	1564	152	375	1704	191			
100	1143	38	170	1289	77	240	1432	116	310	1574	154	380	1714	193			
105	1154	41	175	1299	79	245	1442	118	315	1584	157	385	1724	196			
110	1164	43	180	1309	82	250	1453	121	320	1594	160	390	1734	199			
115	1174	46	185	1320	85	255	1463	124	325	1604	163	395	1744	202			
120	1185	49	190	1330	88	260	1473	127	330	1614	166	400	1754	204			
125	1195	52	195	1340	91	265	1483	129	335	1624	168	405	1764	207			

1.11 Wiring Diagrams

Note: The wiring diagrams in the pages that follow depict wiring as of the date of manual publication. It may not reflect design changes made to the equipment after publication. Refer to the wiring diagram affixed to the unit when actually troubleshooting this equipment.

47 SERIES GAS FRYERS CHAPTER 1: SERVICE PROCEDURES

1.11.1 Standard Controls With Pilot Ignition

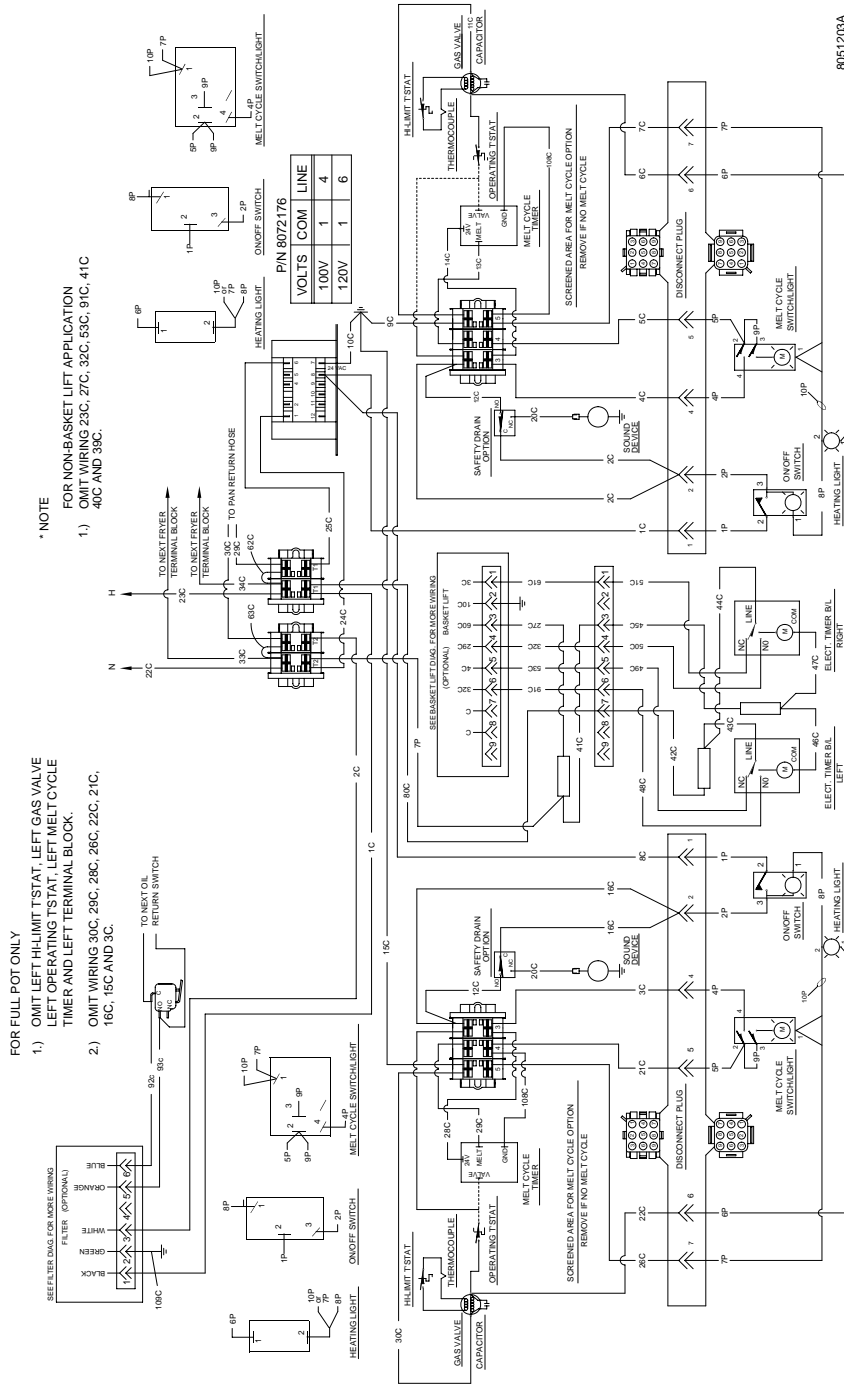

47 SERIES GAS FRYERS CHAPTER 1: SERVICE PROCEDURES

1.11.2 Computer/Controller with Pilot Ignition

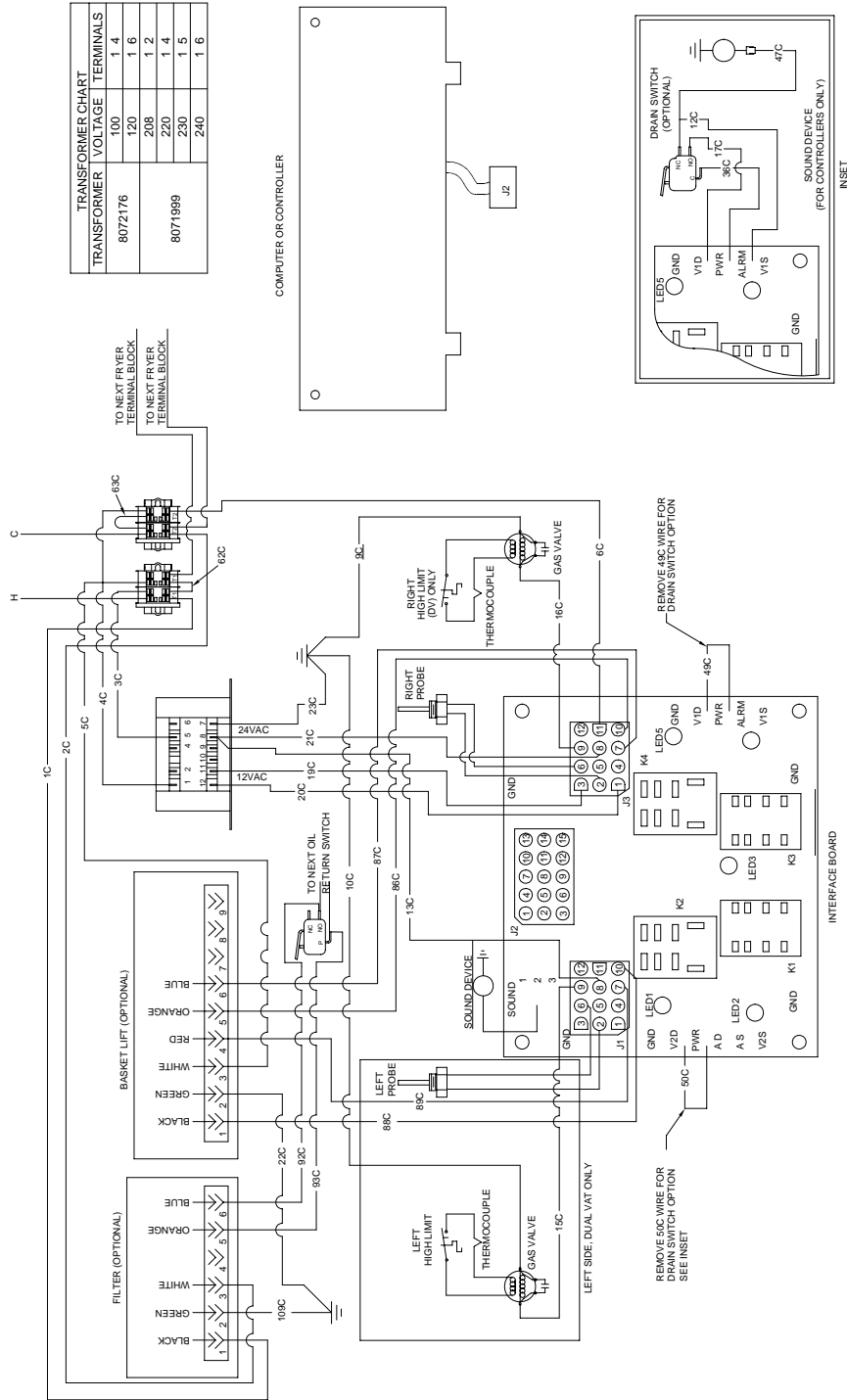

47 SERIES GAS FRYERS CHAPTER 1: SERVICE PROCEDURES

1.11.3 Computer/Controller with Electronic Ignition– 240V-No Basket Lifts

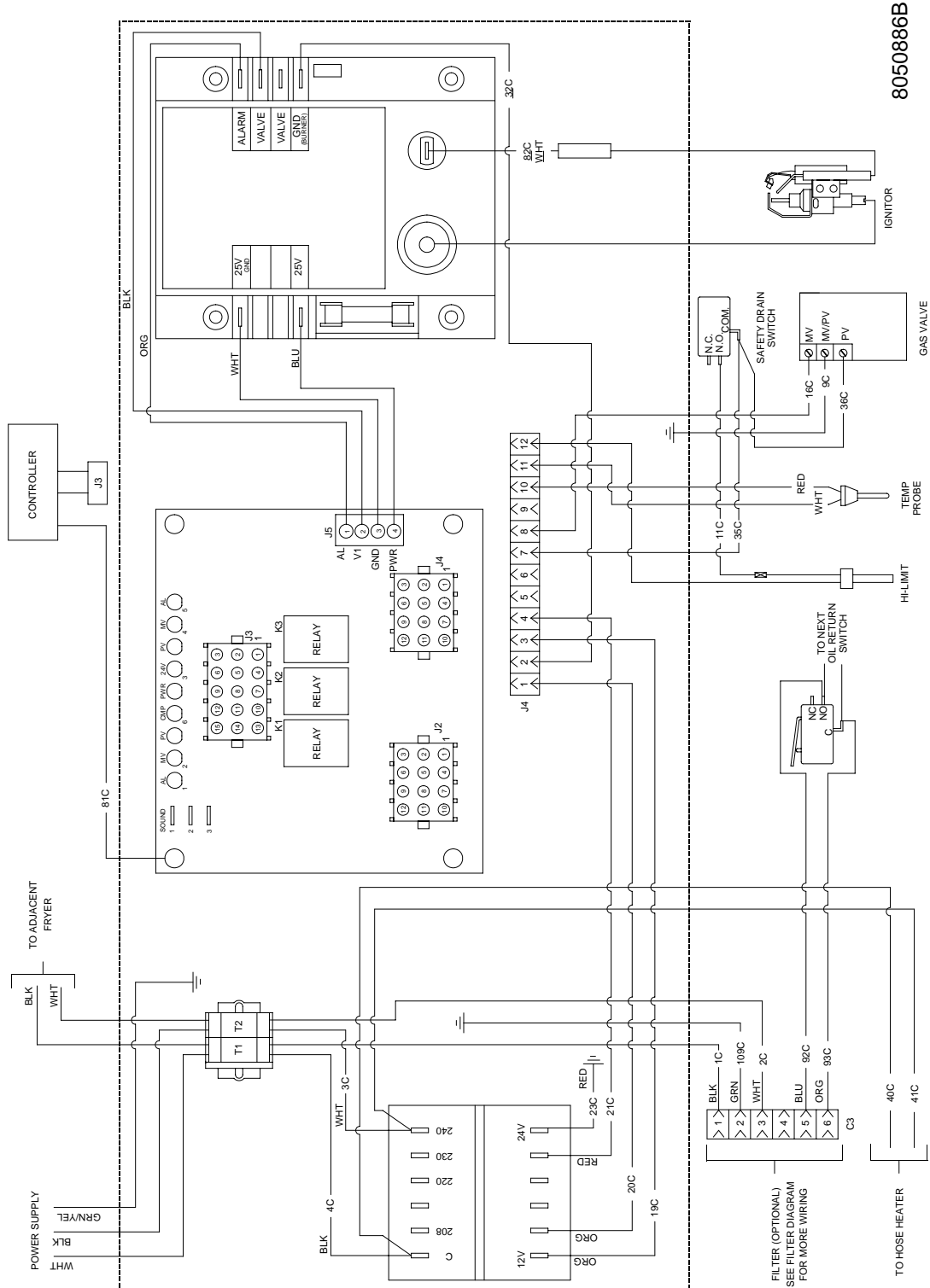

47 SERIES GAS FRYERS CHAPTER 1: SERVICE PROCEDURES

1.11.4 Filter Box Wiring- FootPrint III

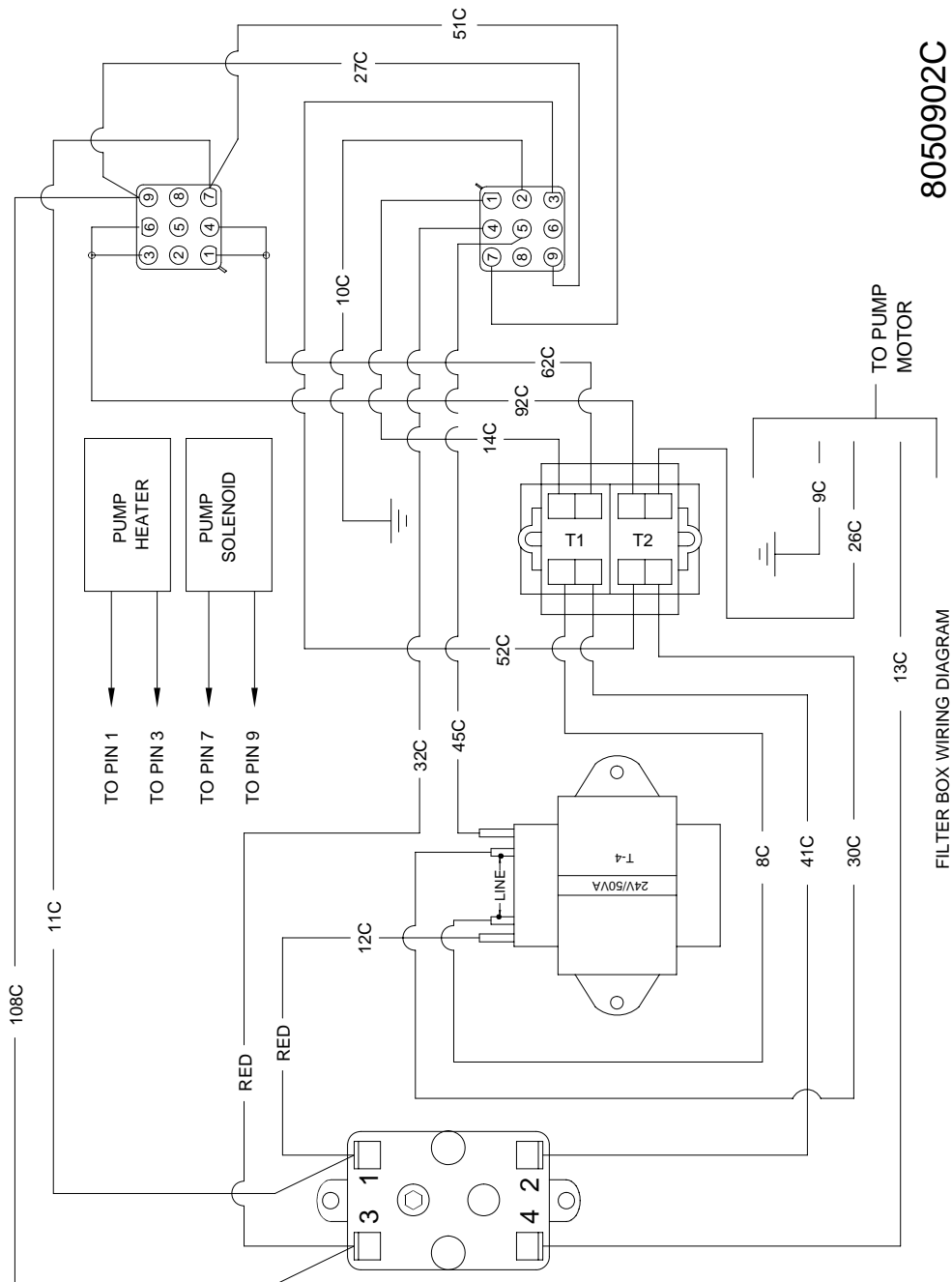

47 SERIES GAS FRYERS

CHAPTER 1: SERVICE PROCEDURES

1.11.5 Modular Basket Lift Wiring

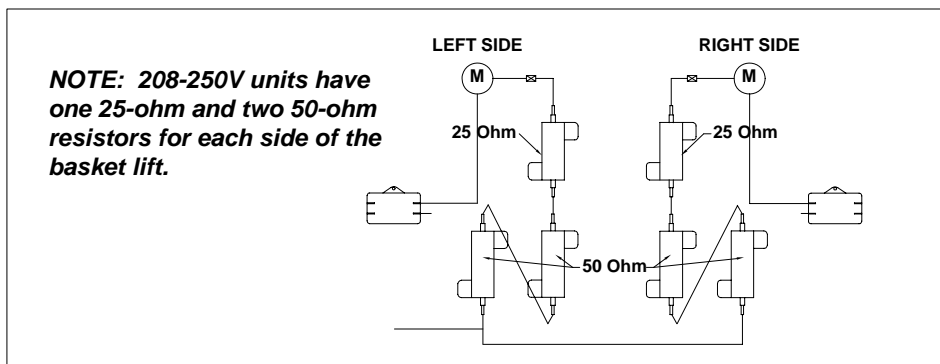
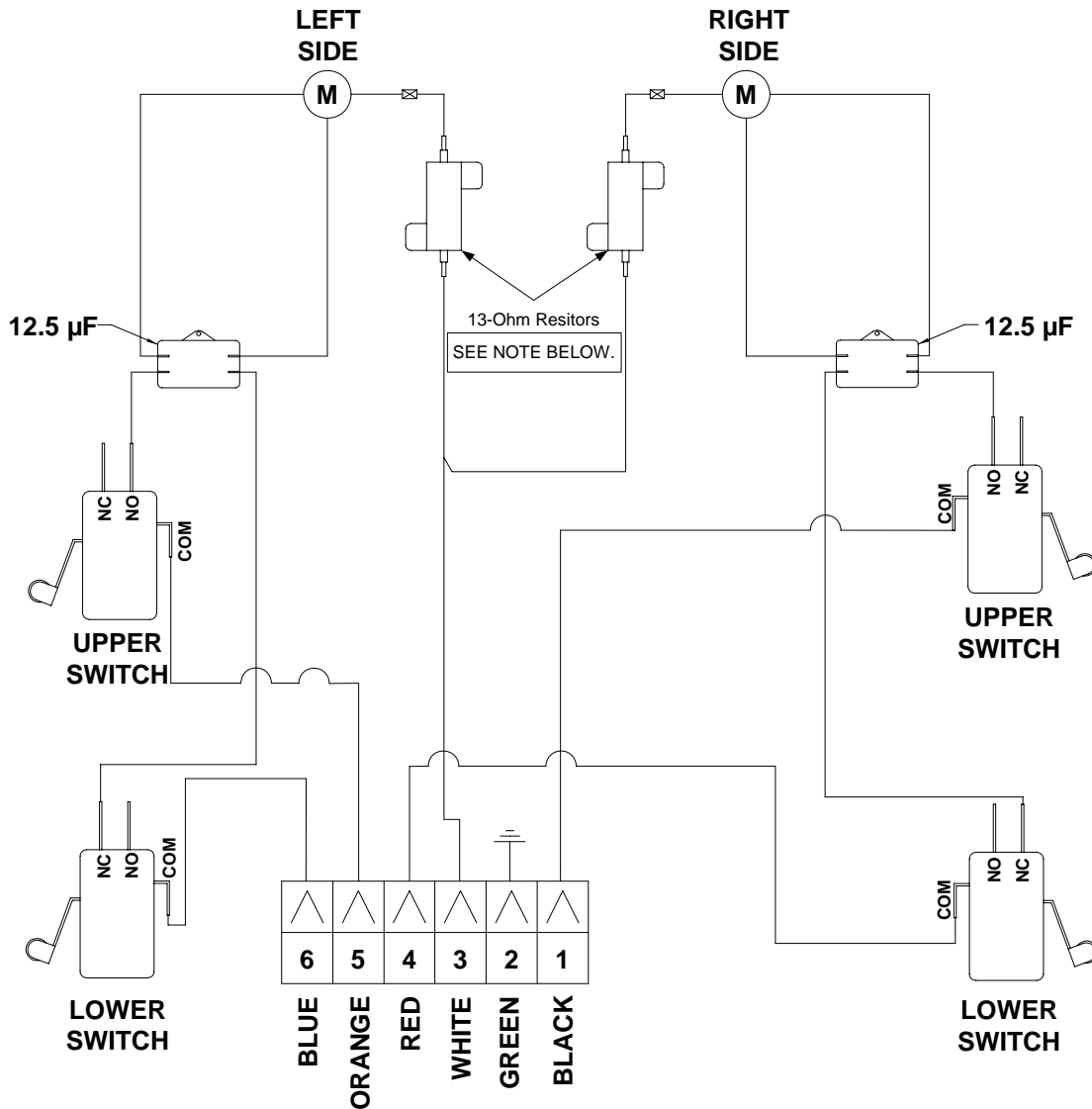

REFERENCES TO LEFT AND RIGHT ARE FROM THE REAR OF THE FRYER

47 SERIES GAS FRYERS

CHAPTER 2: PARTS LIST

2.1 Accessories

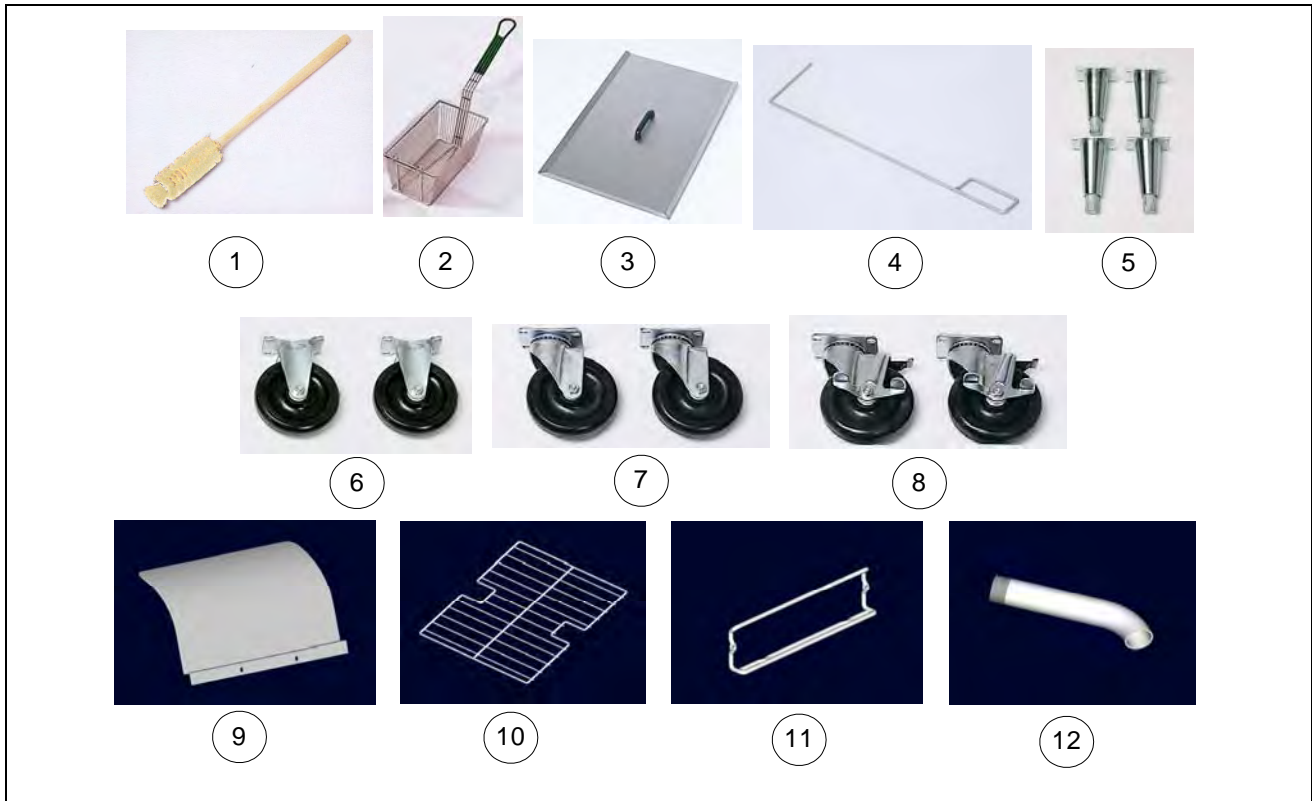

ITEM	PART #	COMPONENT
1	803-0209	Brush, Frypot Clean-out
2	803-0022	Basket, Twin
*	803-0099	Basket, Full
3	806-5518	Frypot Cover, Full-Vat
*	806-3232	Frypot Cover, Split-Vat
*	826-0993SP	Handle Kit, Frypot Cover (Full- and Split-Vat)
4	803-0197	Frypot Clean-out Rod (Fryer's Friend)
5	806-3811	Kit, 4-Leg
*	806-5043	Kit, 1-Leg
6	810-0378	Caster, Rigid
7	810-0356	Caster, 5", Without Brake
8	810-0357	Caster, 5", With Brake
*	826-0900	Chain Restraint Kit (for use with casters above)
9	910-3557	Flue Deflector
10	803-0132	Basket Support Rack, Full Vat
*	803-0338	Basket Support Rack, Dual Vat
11	810-1403	Basket Hanger, Wireform
*	809-0171	Screw, Basket Hanger
12	812-1226SP	Drain Extension Pipe (for use on units without built-in filtration systems)

* Not Illustrated

**47 SERIES GAS FRYERS
CHAPTER 2: PARTS LIST**

2.2 Burner Manifold Assemblies and Component Parts

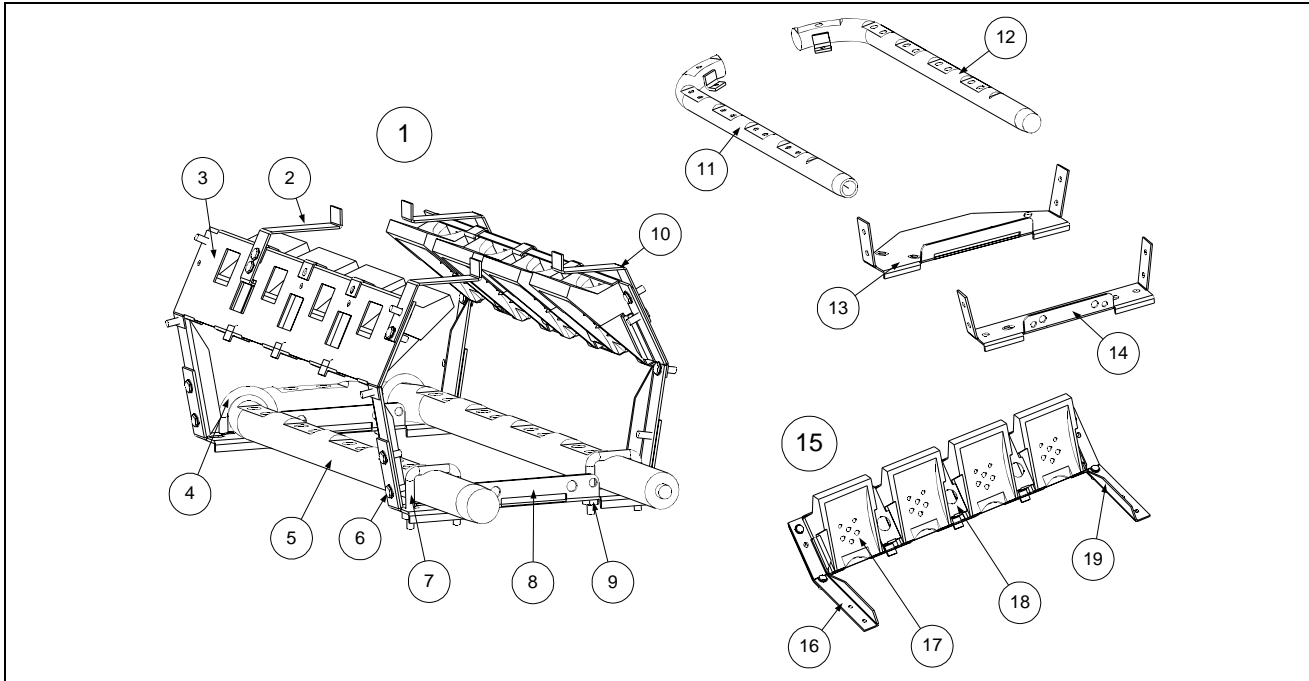

ITEM	PART #	COMPONENT
1	806-5927SP	Burner Manifold Assembly, Full Vat, Complete
*	806-5928SP	Burner Manifold Assembly, Dual Vat, Complete
2	910-2027	Standoff, Target- Rear
3	910-2031	Support, Target, Back Plate
4	809-0499	U-bolt & Retainer- ¼-20 x 1-½"
5	810-0989	Manifold, Burner- Full-vat
6	809-0500	Screw, 410 SS, # 10 x ½, Hex Washer Head
7	809-0498	U-bolt–Square-bent- ¼-20 x 1-½"
8	910-2022	Bracket, Manifold Mounting, Full Vat
9	826-1372	Nut, ¼-20 w/Grip (Qty: 10)
10	910-2027	Standoff, Target- Front
11	810-0987	Burner Manifold, Dual Vat, Left
12	810-0988	Burner Manifold, Dual Vat, Right
13	910-2024	Bracket, Manifold Mounting, Dual Vat, Rear
14	910-2023	Bracket, Manifold Mounting, Dual Vat, Front
15	806-7949	Burner Manifold Sub-Assembly (Target Assembly)
16	911-2029	Support, Target, Left End
17	814-0034	Burner Target, Ceramic
18	910-2025	Bracket, Target Retaining
19	912-2029	Support, Target, Right End
*	826-1357	Orifice, Burner Manifold, Natural Gas (Drill #53, 1.45mm— Qty: 10)
*	826-1387	Orifice, Burner Manifold, LP Gas (Drill #65, 0.86mm— Qty: 10)

* Not Illustrated

47 SERIES GAS FRYERS CHAPTER 2: PARTS LIST

2.3 Burner Ignition System Components

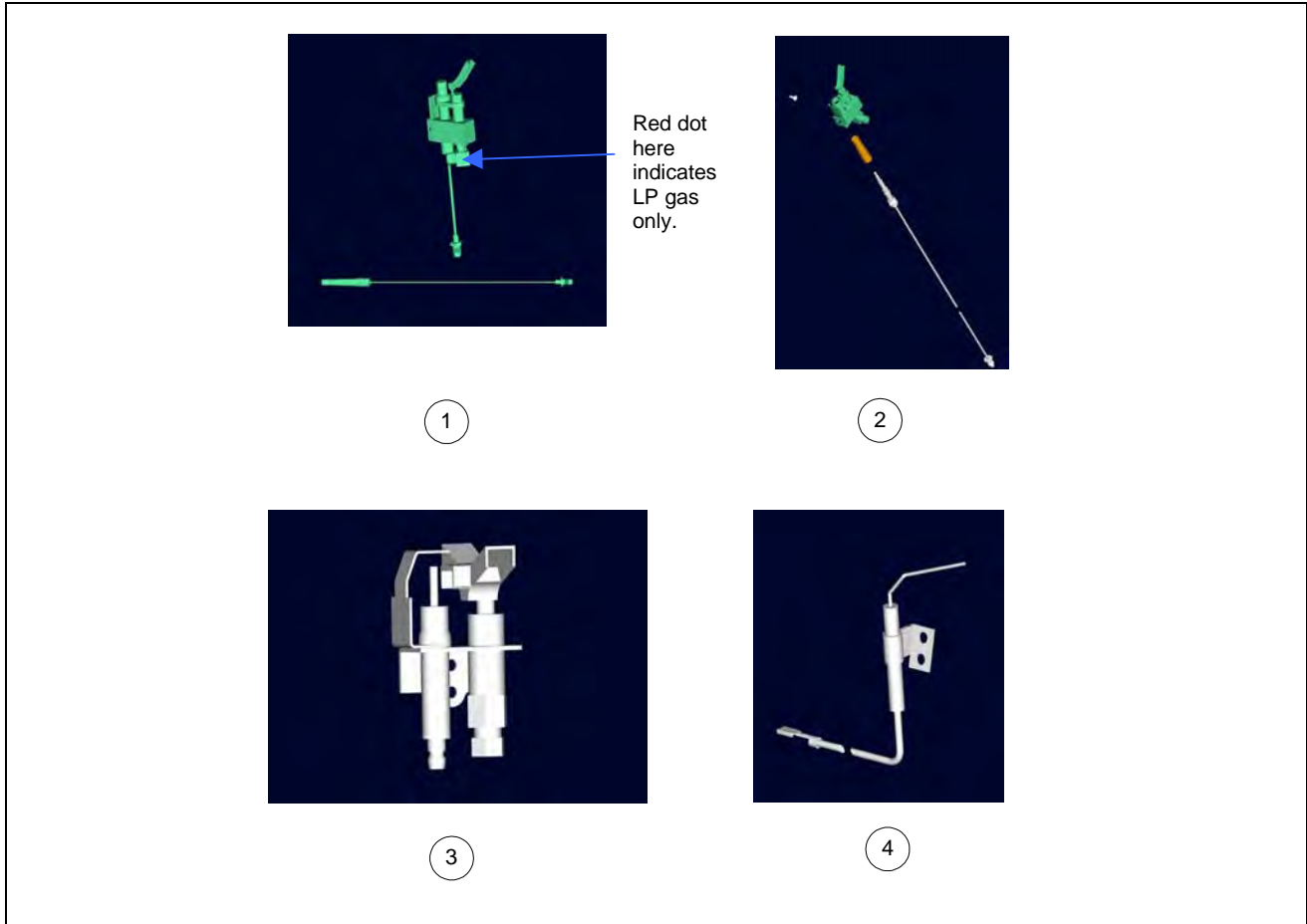

ITEM	PART #	COMPONENT
1		Pilot Assembly w/Thermopile (for use w/Non-CE Pilot Ignition Systems)
	810-0615	Natural Gas
	810-0616	Propane Gas
	810-1873	Thermopile
2		Pilot Assembly w/Thermocouple (for use w/CE Pilot Ignition Systems)
	806-8688SP	Natural Gas
	806-8689SP	Propane Gas
	812-1284	Thermocouple
3		Ignitor Assembly, Honeywell (for use w/Electronic Ignition Systems)
	807-1707	Natural Gas
	807-1708	Propane Gas
4	807-1928	Electrode, Flame Sensor (for use w/Electronic Ignition Systems)
*	806-5830SP	Ignition Cable (Spark Plug Wire)
*	826-1155	Ignitor Kit, Piezo (Optional)
*	810-1001	Trigger
*	807-1906	Electrode Assembly

* Not Illustrated

**47 SERIES GAS FRYERS
CHAPTER 2: PARTS LIST**

2.4 Gas Valve Assemblies and Connection Components



ITEM	PART #	COMPONENT
1		Gas Valve Assembly (for use w/CE Pilot Ignition Systems)
	807-2091	Natural Gas
	807-2127	Propane Gas
	810-1155	CE Accessory Kit- (Converts Inlet/Outlet Flanges to ½" NPT)
2		Gas Valve Assembly (for use w/Non-CE Electronic Ignition Systems)
	810-0786	Natural Gas
	810-0787	Propane Gas
3		Gas Valve Assembly (for use w/Non-CE Pilot Ignition Systems)
	807-3294	Natural Gas
	807-3295	Propane Gas (Full-vat Units)
*	806-0236	Capacitor, .002 µF (for use w/810-0786, 810-0787)
*		Vent Tube, Gas Valve
	810-1166	For use w/CE Gas Valves 807-2091 and 807-2127
	810-0691	For use w/Non-CE Gas Valves 810-0786, 810-0787
*		Hose, Flexible, Gas
	810-0084	¾-inch (19.05mm) ID, 48 inches (1.2m) long
	810-0085	1-inch (25.4mm) ID, 48 inches (1.2m) long
*		Quick Disconnect Fitting, Female
	810-0072	¾-inch (19.05mm)
	810-0073	1-inch (25.4mm)
*		Quick Disconnect Fitting, Male
	810-0070	¾-inch (19.05mm)
	810-0074	1-inch (25.4mm)

* Not Illustrated

**47 SERIES GAS FRYERS
CHAPTER 2: PARTS LIST**

2.5 Gas Manifold Assemblies

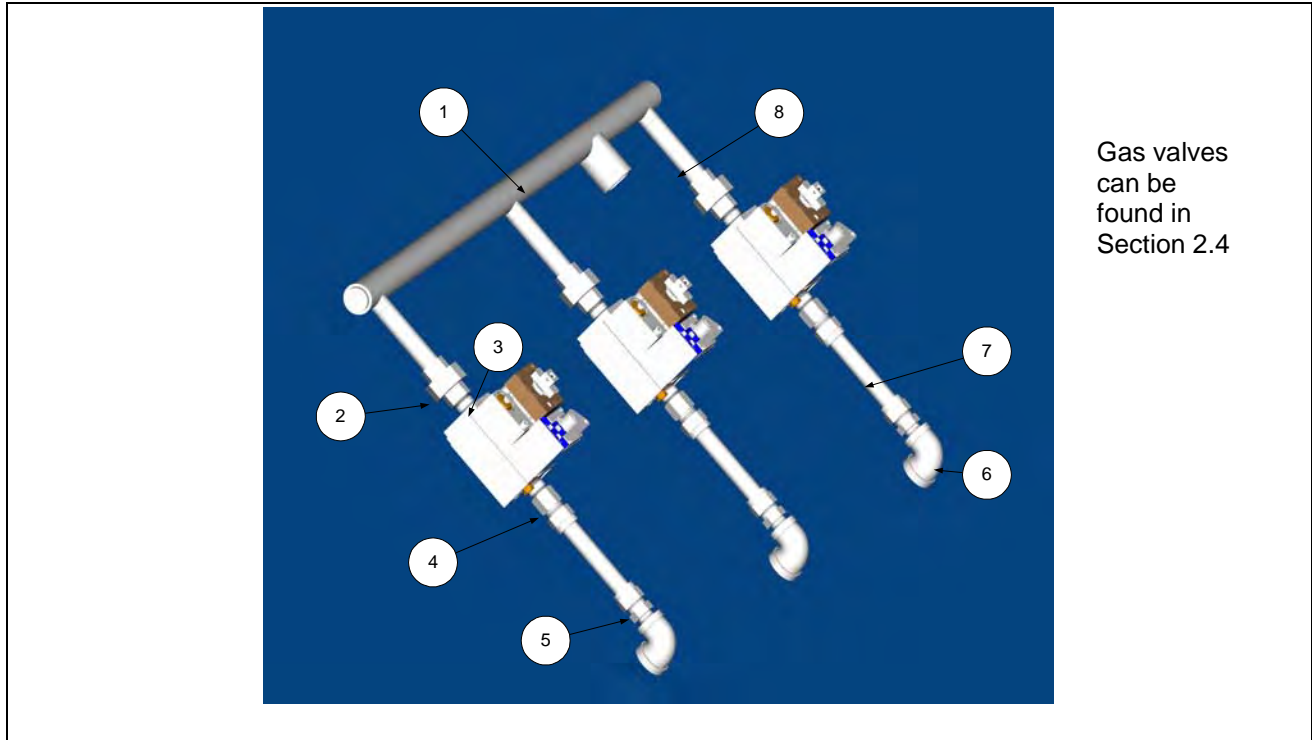

ITEM	PART #	COMPONENT
1		Gas Manifold
	810-0995	FP247
	810-0997	FP247-2L
	810-0996	FP247-2R
	810-0950	FP247-4
	810-0960	FP347
	810-0994	FP347-2L
	810-0947	FP347-2R
	810-0993	FP347-4L
	810-0991	FP347-4R
	810-0992	FP347-6
	810-1119	MJ147-2
2	813-0173	Union, 1/2" NPT Black Pipe
3	813-0087	Nipple, 1/2 x 1-1/2" NPT Black Pipe
4	810-1669	Adapter, Female- 5/8 O.D. x 1/2"
5	810-1668	Adapter, Male- 5/8 x 1/2"
6	813-0068	Elbow, Reducing- 3/4 x 1/2"
7		Flexline
	810-1159	5" (Used for all but MJ147-2)
	810-1067	8.5" (Used for MJ147-2 only)
8	813-0093	Nipple, 1/2 x 4" NPT Black Pipe

47 SERIES GAS FRYERS
CHAPTER 2: PARTS LIST

2.6 Cabinet Assemblies and Component Parts

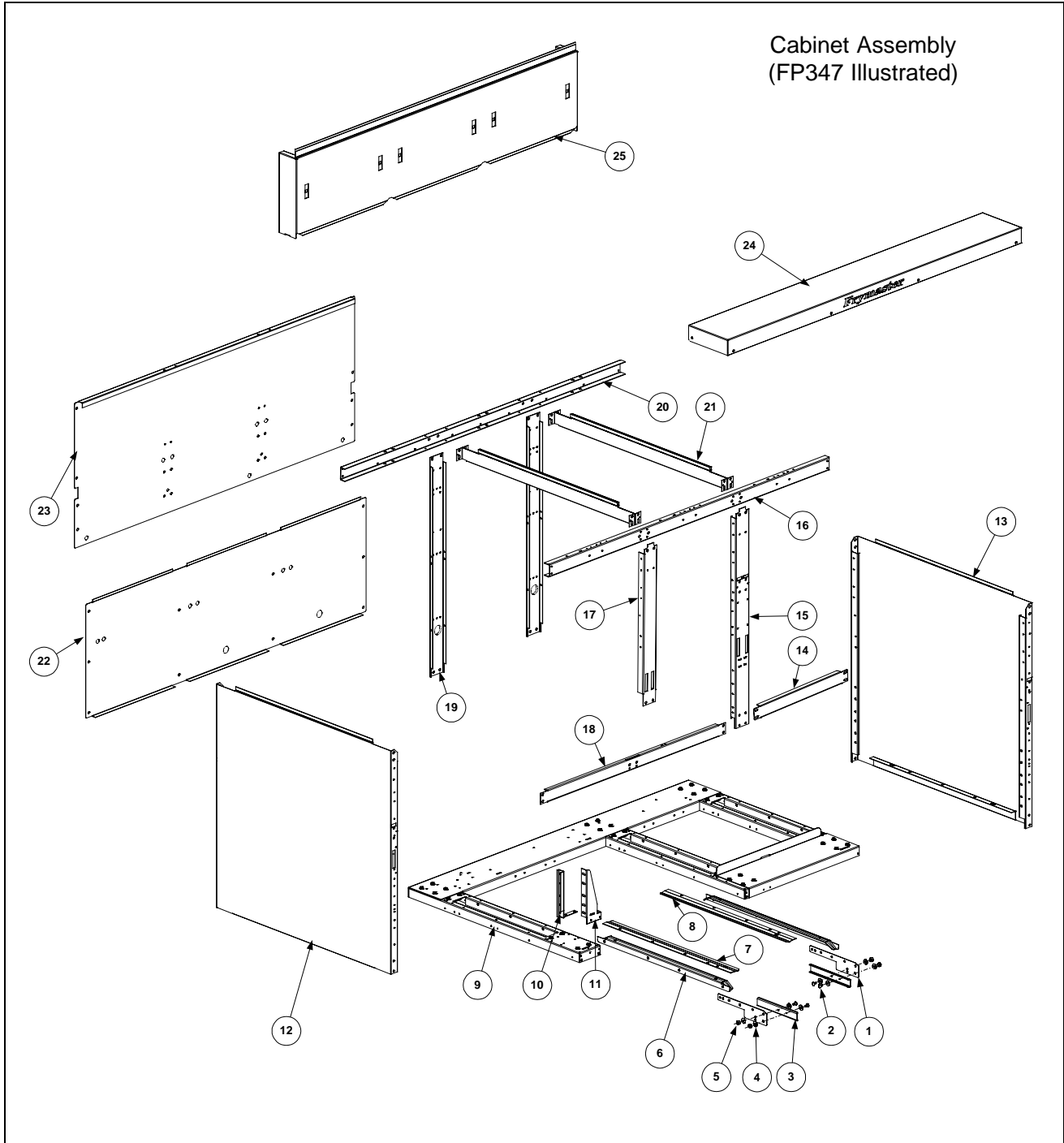

**47 SERIES GAS FRYERS
CHAPTER 2: PARTS LIST**

ITEM	PART #	COMPONENT
1	900-1959	Bracket, Filter Lock
2	809-0422	Screw, FootPrint III Cover
3	900-1957	Lock, Filter
4	809-0189	Washer, ¼ Flat
5	826-1372	Nut, Hex- ¼-20 Nickel Plated (Qty:10)
6	910-5244	Rail, Lower- Unitary (Left or Right)
7	911-4690	Rail, Filter, Top Left
8	912-4690	Rail, Filter, Top, Right
*	900-5671	Support, Filter Hose (FP47's)
*	900-5673	Shield, Heat (FP47's)
9	806-7350SP	Base Assembly, FP347
*	806-7351SP	Base Assembly, FP447
*	806-7349SP	Base Assembly, FP247
*	900-2568SP	Base Assembly, MJ47
*	806-7346SP	Base Assembly, MJ247
*	806-7347SP	Base Assembly, MJ347
*	806-7348SP	Base Assembly, MJ447
10	901-1948	Channel, Side Support- Left
*	902-1948	Channel, Side Support- Right
11	901-1810	Gusset, Cabinet- Left
*	902-1810	Gusset, Cabinet- Right
12	910-7678SP	Panel, Side, Left or Right, w/No Access Openings (S/S)
*	900-7678SP	Panel, Side, Left or Right, w/No Access Openings (CRS)
*	911-7679SP	Panel, Side, Left, w/4 Access Openings (S/S)
*	901-7679SP	Panel, Side, Left, w/4 Access Openings (CRS)
13	912-7679SP	Panel, Side, Right, w/4 Access Openings (S/S)
*	902-7679SP	Panel, Side, Right, w/4 Access Openings (CRS)
14	900-2562	Support, Cross Cabinet
15	900-7734	Post, Long Cabinet
16	900-9430	Brace, Top- Front, Unitary Cabinet
17	900-4773	Post, Short- Door
18	900-7729	Support, Cross Cabinet
19	900-2797	Support, Cabinet- Rear
20	900-9352	Brace, Top- Rear
21	900-7326	Divider, Cabinet
22	900-2798SP	Back, Lower- FP & MJ347
*	900-2799SP	Back, Lower- FP & MJ247
*	900-2288	Back, MJ47

* Not Illustrated

List continued on following page.

**47 SERIES GAS FRYERS
CHAPTER 2: PARTS LIST**

ITEM	PART #	COMPONENT
23	900-9415	Back, Upper- FP & MJ347
*	900-7658	Back, Upper- FP & MJ247
*	809-0266	Screw, #10-1/2 Phillips Head, Zinc Plated
24	824-0406	Top Cap, Triple
*	824-0407	Top Cap, Quad
*	824-0404	Top Cap, Single
*	824-0405	Top Cap, Double
25	823-2541	Flue Cap, Triple Fryer Battery
*	823-2540	Flue Cap, Double Fryer Battery
*	910-5018	Flue Cap, Single Fryer
*	910-3122	Battery Strip, Flue Cap
*	826-1351	Nutsert (For Basket Hanger Screw- Qty:10)
*	900-5486	Support, Flue Cap To Back
*	910-7443	Strip, Top Connecting
* Not Illustrated		

47 SERIES GAS FRYERS CHAPTER 2: PARTS LIST

2.6.1 Door Assemblies and Component Parts

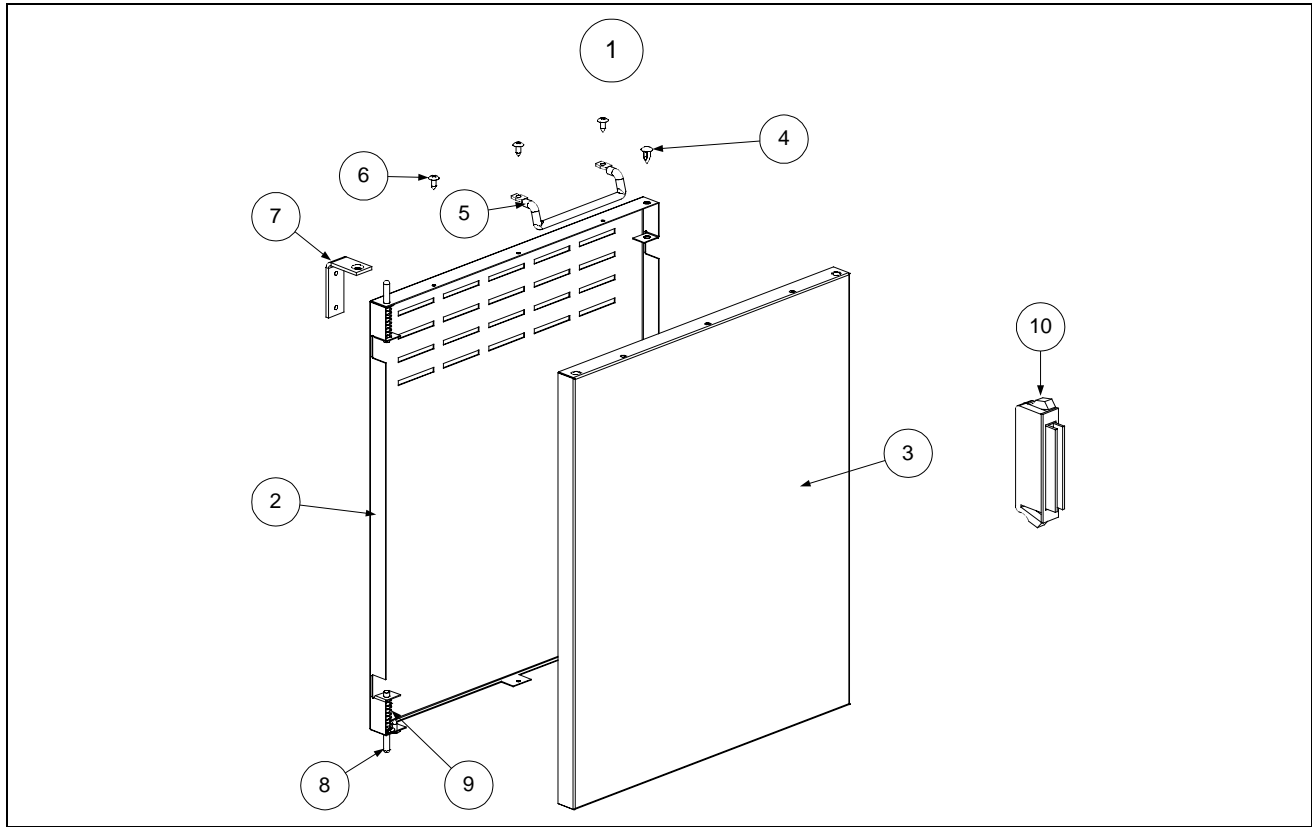

ITEM	PART #	COMPONENT
1	806-7383SP	Door Assembly, Left
*	806-7384SP	Door Assembly, Right
2	900-2815	Liner, Door, Left or Right
3	824-0580SP	Panel, Door, Left or Right
4	809-0545	Clip, Nylon Arrow
5	810-1422	Handle, Door, Wireform
6	809-0266	Screw, #10 x ½, Phillips, Zinc Plated
7	810-1508	Hinge, Door
8	106-0554SP	Door Pin Assembly
*	809-0193	Washer, Nylon- Flat ¼" (Door Pin Bushing)
9	826-1343	Spring, Door Hinge (Qty: 10)
10	810-1105	Magnet, Door

* Not Illustrated

47 SERIES GAS FRYERS
CHAPTER 2: PARTS LIST

2.7 Component Box/Shield Component Parts

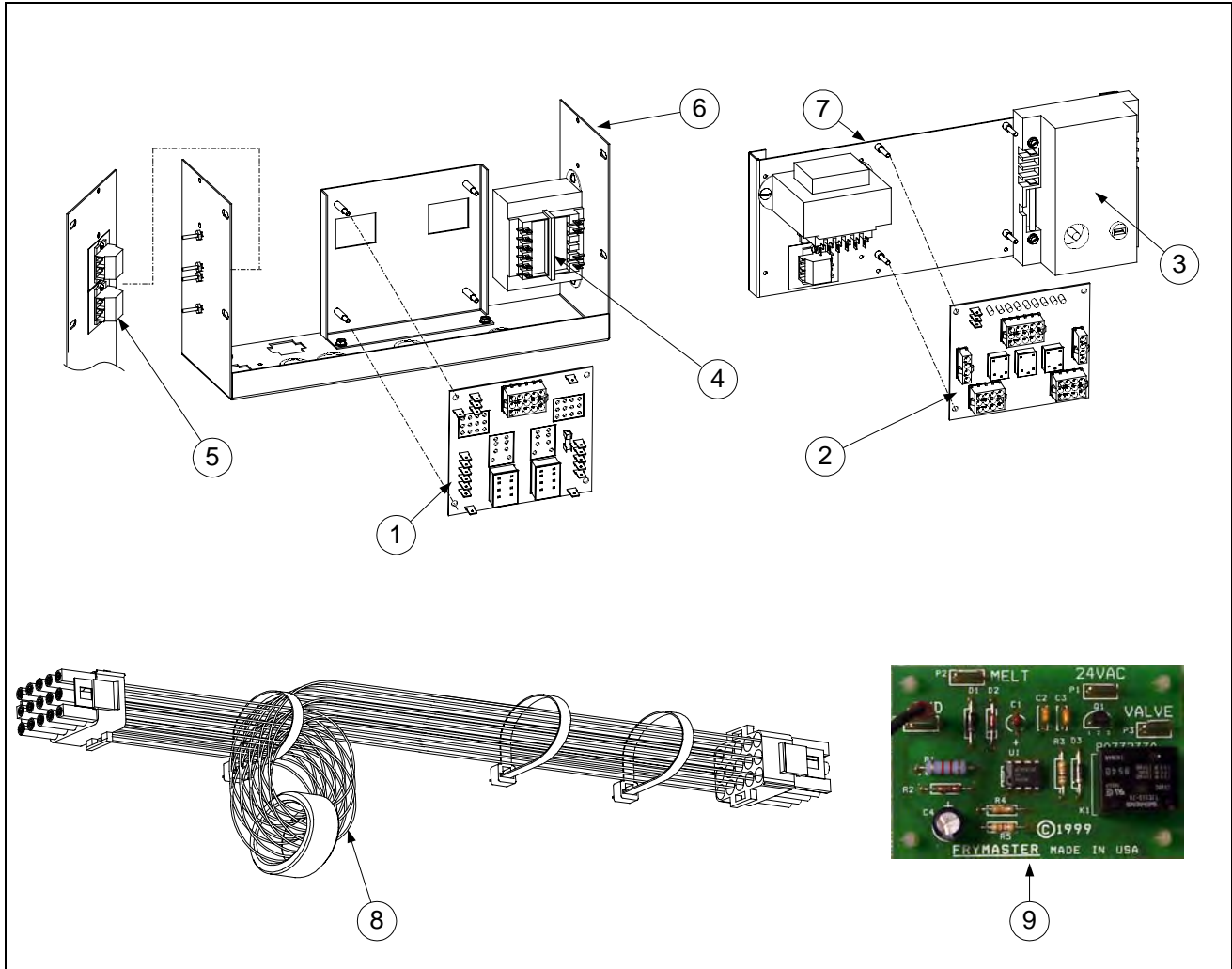

**47 SERIES GAS FRYERS
CHAPTER 2: PARTS LIST**

ITEM	PART #	COMPONENT
1	106-0386	Board, Interface (Without Electronic Ignition) (also replaces 806-3398)
*	807-0833	Relay, Heat (For 806-3398)
*	807-0834	Relay, Basket Lift- 12V 15A (For 806-3398)
2	806-5857	Board, Interface (With Electronic Ignition)
*	809-0349	Spacer, Aluminum- Interface Board- 4-mm x 6-mm
*	807-1241	Spacer, Aluminum- Interface Board - 5/8" Unthreaded
*	806-3660	Sound Device, High Output
*	806-4797	Buzzer, 24V
3	807-1006	Module, Ignition, 4-Second Delay, Honeywell
*	807-2971	Module, Ignition, PCB (Australia Only)
*	806-5879SP	Wire Assembly, Ignition Module
4	807-2176	Transformer, V/F Dual Voltage- 100-120VAC
*	807-1999	Transformer, V/F Dual Voltage- 208-240VAC
5	810-1164	Block, Terminal (Screwless)- 2-Wire
*	810-1168	Block, Terminal (Screwless)- 3-Wire
6		Component Shield Assembly- Pilot Ignition
*	806-6907SP	100-120V Full Vat- Includes Items #1, #4 and #5
*	806-6904SP	100-120V Dual Vat- Includes Items #1, #4 and #5
*	806-6835SP	230-240V Full Vat- Includes Items #1, #4 and #5
*	806-6832SP	230-240V Dual Vat- Includes Items #1, #4 and #5
7		Component Shield Assembly- Electronic Ignition
*	806-8174SP	100-120V Full Vat- Includes Items #2, #3, #4 and #5
*	806-7988SP	230-240V Full Vat- Includes Items #2, #3, #4 and #5
*		Component Shield Assembly- Solid State Melt Cycle Timer
	806-6908SP	100-120V Full Vat- Includes Items #4, #5 and #9
	806-6905SP	100-120V Dual Vat- Includes Items #4, #5 and #9
	806-6836SP	230-240V Full Vat- Includes Items #4, #5 and #9
	806-6833SP	230-240V Dual Vat- Includes Items #4, #5 and #9
*		Component Shield Assembly- No Melt Cycle or Interface Board
*	806-6909	100-120V Full Vat- Includes Items #4 and #5
*	806-6906	100-120V Dual Vat- Includes Items #4 and #5
*	806-6837	230-240V Full Vat- Includes Items #4 and #5
*	806-6834	230-240V Dual Vat- Includes Items #4 and #5
*	806-8175SP	Control Box Assy, FP/MJ-47, Full Vat, Electronic Ignition, 120V
*	806-8048SP	Control Box Assy, FP/MJ-47, Full Vat, Electronic Ignition, 240V
8	806-2071	Cable Assembly, 15-Pin, Computer to Interface Board
*	WIR0163SP	Cable Assembly, Transformer Box to Interface Board
*	806-5830SP	Cable Assembly, Ignition (Spark Plug Wire)
9	826-1546	Kit, Solid State Melt Cycle Timer

* Not Illustrated

**47 SERIES GAS FRYERS
CHAPTER 2: PARTS LIST**

2.8 Probes, High-Limits and Basketlift Timers

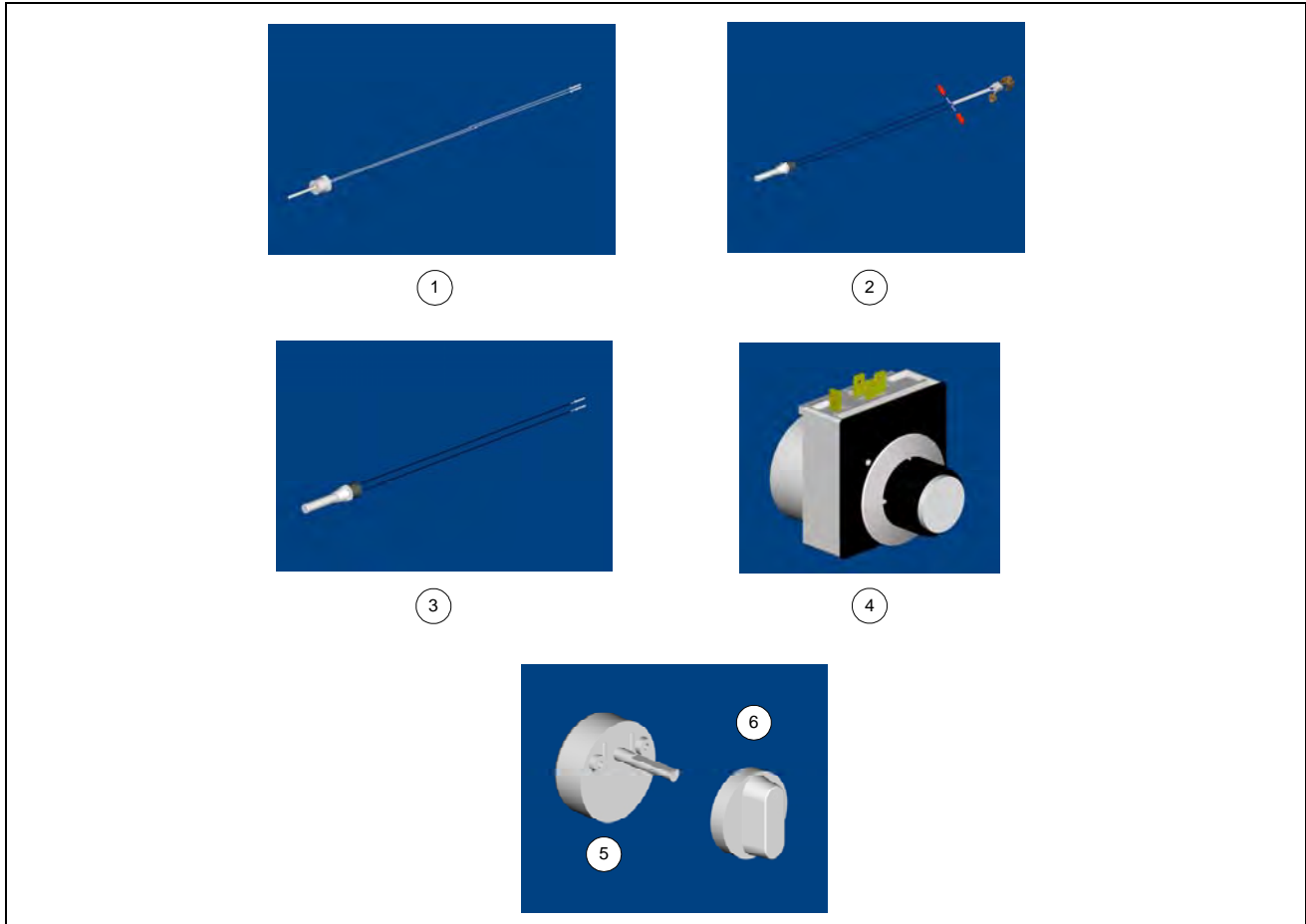

ITEM	PART #	COMPONENT
1	806-4206	Probe, Temperature Control (not for use with Thermostat Controllers)
*	210-0681	Probe Guard
2	806-7550	Thermostat, High-Limit (CE)
3	826-1177	Thermostat, High-Limit (Non-CE)
4		Timer, Basket Lift, Electric
*	826-1575	120V, 60 Hz, 5-Minute
*	826-1552	120V, 60 Hz, 15-Minute
*	807-0401	240V, 50/60 Hz, 18-Minute
*	810-1822	Knob, Electric Basket Lift Timer (Telechron)
*	810-1823	Push Button, Electric Basket Lift Timer (Telechron)
5	810-0585	Timer, Basket Lift, Mechanical, 15-Minute
6	810-1287	Knob, Mechanical Timer
*	826-1020	Timer Service Kit (Includes Timer, Knob & Bezel)

* Not Illustrated

**47 SERIES GAS FRYERS
CHAPTER 2: PARTS LIST**

2.9 Operating Thermostat and Related Components

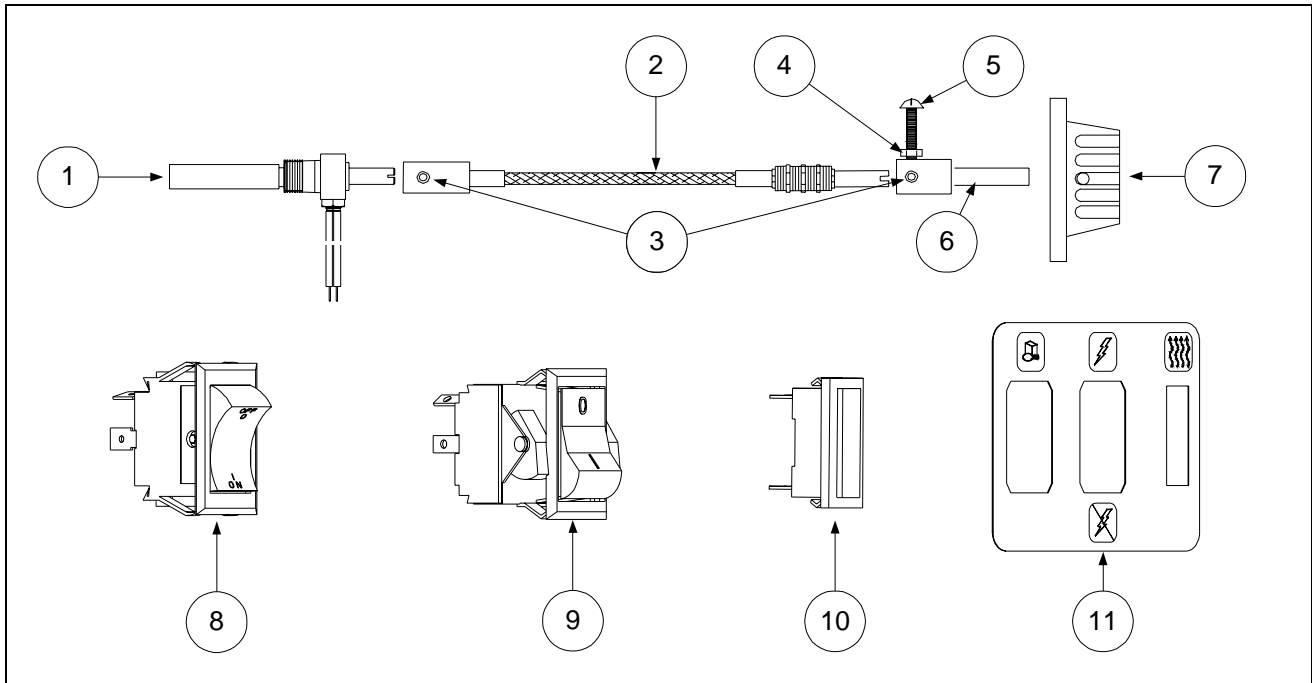

ITEM	PART #	COMPONENT
1	806-0183	Thermostat, Operating (for use with Thermostat Controller only)
2	810-0999	Shaft, Flexible
3	809-0157	Set Screw
4	809-0050	Nut, Hex
5	826-1361	Screw, Stop (Qty: 25)
6	810-0276	Adapter, Shaft End
7	810-0334	Knob, Thermostat
8	807-3498	Switch, Rocker, Melt Cycle ON/OFF
9		Switch, Rocker, Melt Cycle I/O, w/24V Lamp
	807-2196	Green (CE)
	807-2197	Amber (CE)
10	807-1525	Light, 24V, White
11	802-0765	Label, Control Panel

47 SERIES GAS FRYERS CHAPTER 2: PARTS LIST

2.10 Computers and Controllers

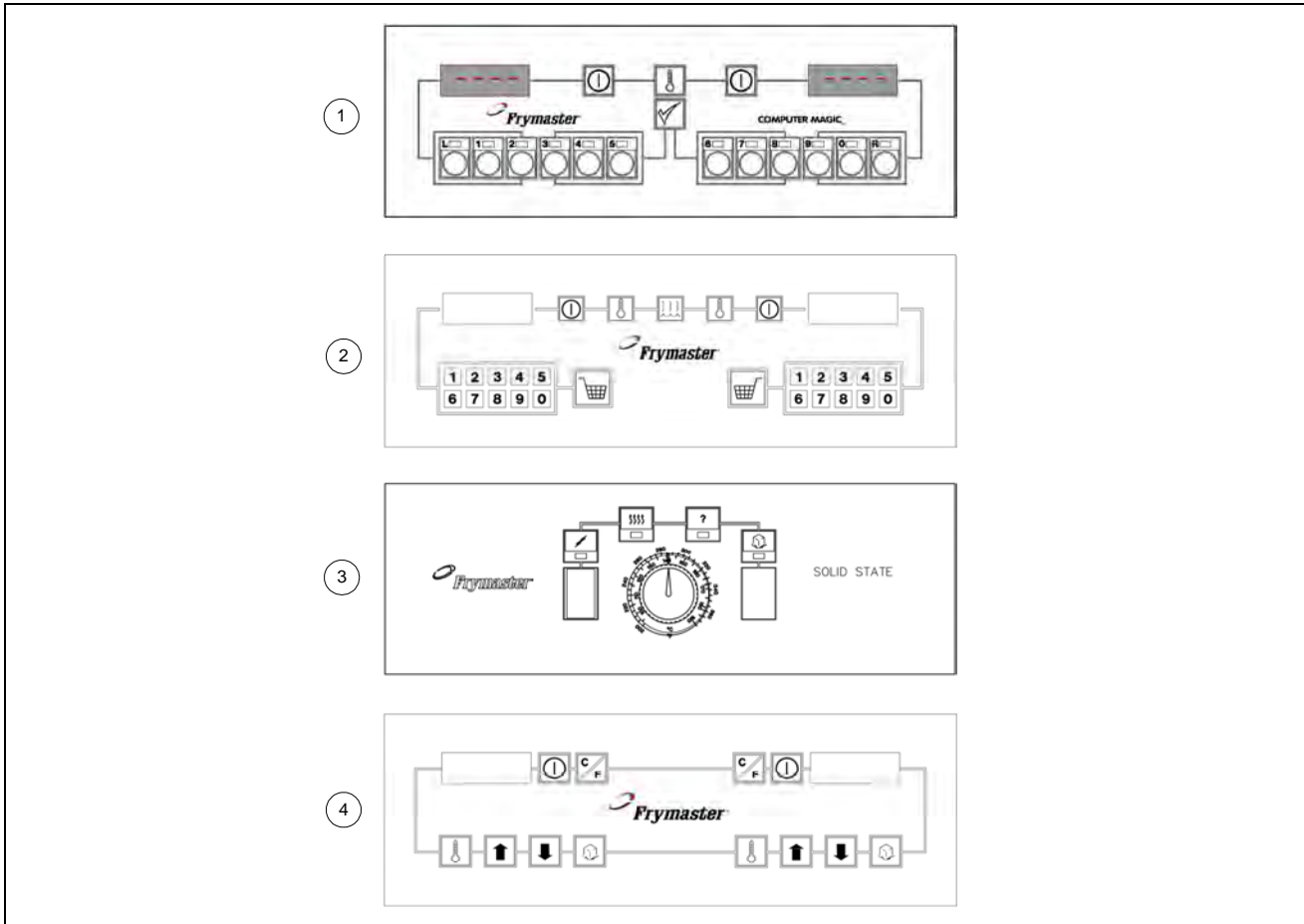

ITEM	PART #	COMPONENT
1		Computer Magic III
*	106-1149SP	Full Vat
*	106-1184SP	Dual Vat
*	106-1199SP	Full Vat (CE)
*	106-1203SP	Dual Vat (CE)
2		Computer, Basket Lift Timer
*	106-2079SP	Full Vat
*	806-7484SP	Full Vat (CE)
3		Analog Controller
*	806-3564	Dual Vat
*	806-3559	Full Vat
4		Digital Controller
*	106-1512	Dual Vat
*	106-1501	Full Vat

* Not Illustrated

**47 SERIES GAS FRYERS
CHAPTER 2: PARTS LIST**

2.11 Filter Base Assembly- FootPrint III Series

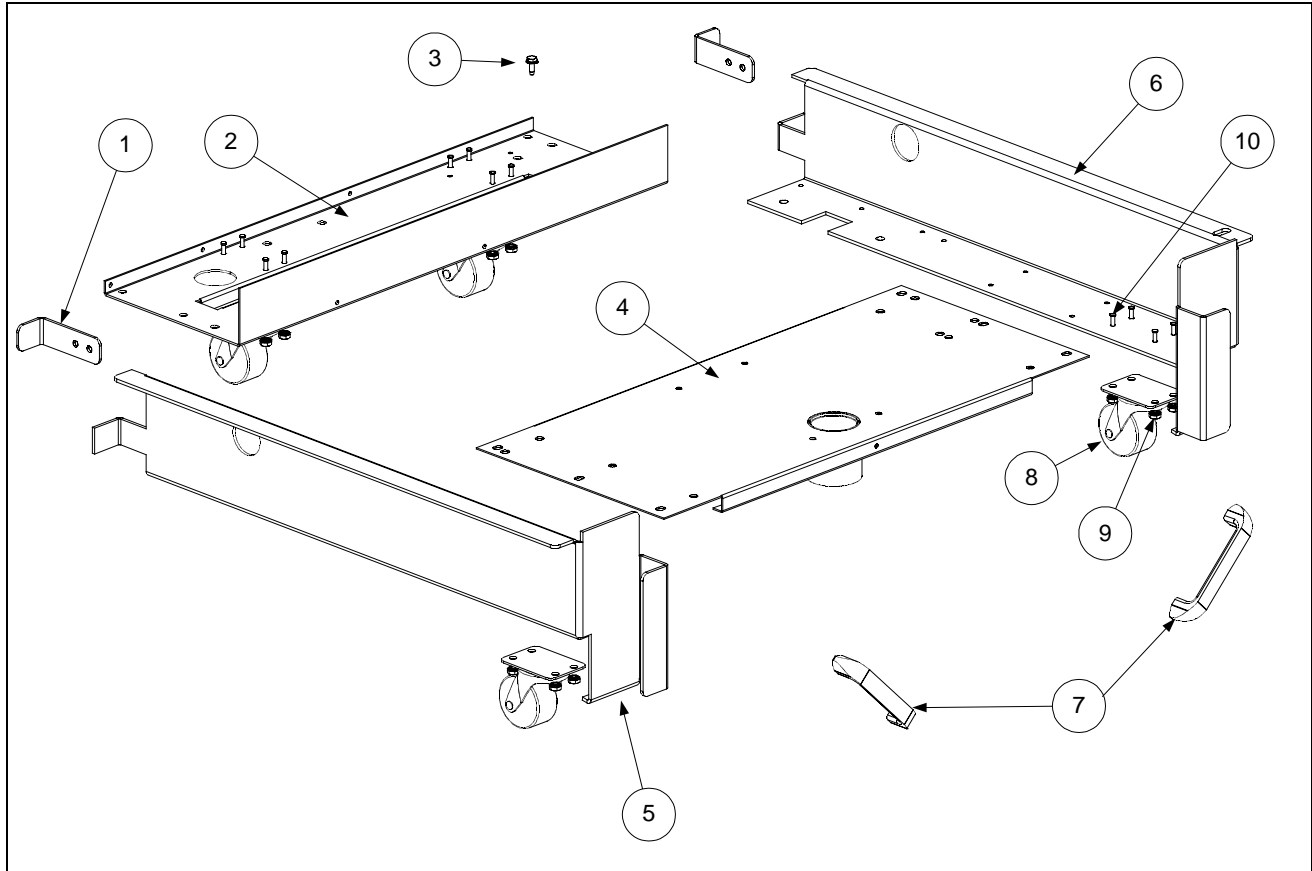

ITEM	PART #	COMPONENT
1	900-1953	Bracket, Filter Pan Lock
2	900-5396	Support, Motor
3	826-1374	Screw, #10-½ Hex Head (Qty: 25)
4	823-2289	Support, Filter Pan
5	201-0755	Frame, Base, Left Side
6	202-0755	Frame, Base, Right Side
7	826-0993SP	Handle (FPIII Units Prior to 4/98)
8	810-0006	Caster, Swivel, Rokite #127-2
9	826-1376	Nut, 10-32 Hex (Qty: 10)
10	809-0021	Stud, 10-32 x 5/8 S/S
*	806-5954SP	Base Assembly, Complete

* Not Illustrated

**47 SERIES GAS FRYERS
CHAPTER 2: PARTS LIST**

2.12 Filter Motors, Pumps and Related Components

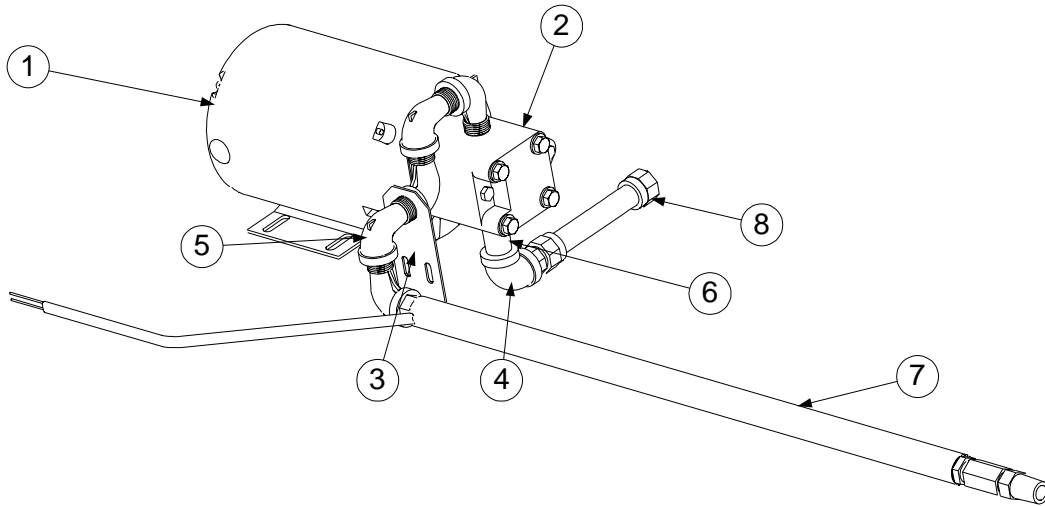

Standard FP III Configuration (Prior to August 1997)

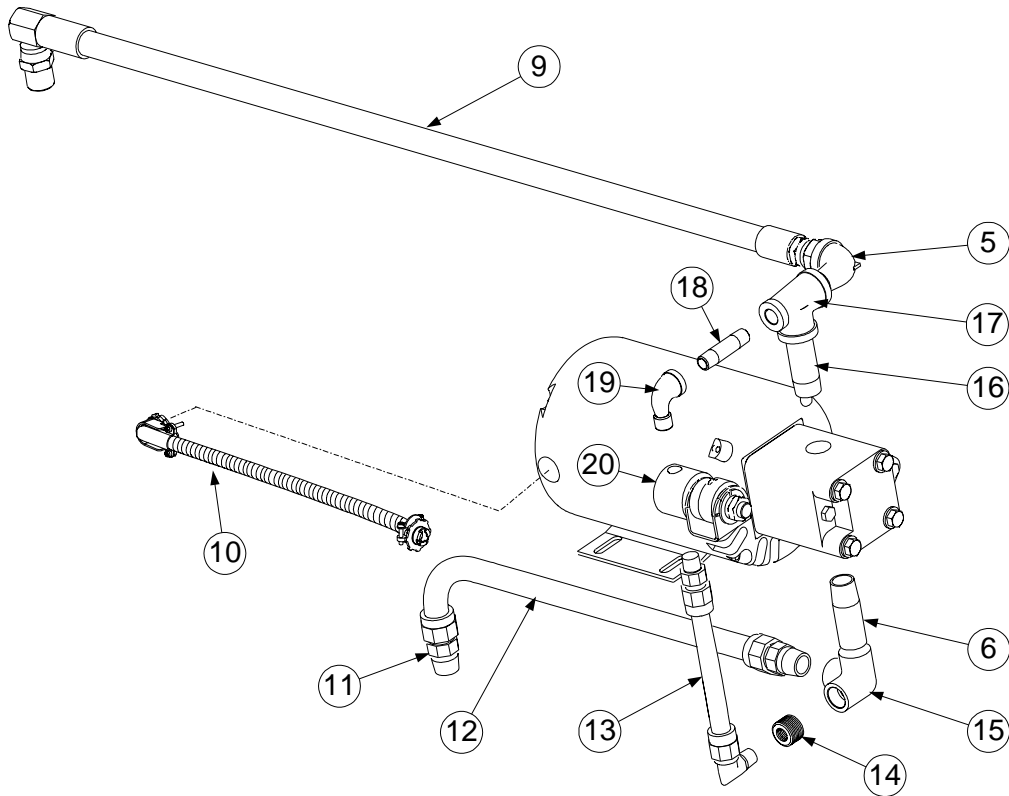

Standard FP III Configuration (August 1997 and Later)

**47 SERIES GAS FRYERS
CHAPTER 2: PARTS LIST**

ITEM	PART #	COMPONENT
1		Motor and Gasket Kits
	826-1712	100-115VAC
	826-1266	208VAC
	826-1270	230-250VAC
*	900-7558	Cover, Motor
2	826-1261	Pump, 4GPM (15LPM) (includes gasket 816-0093)
*	816-0093	Gasket, Pump/Motor
3	900-1958	Support, Oil Return
4	813-0062	Elbow, ½", 90°
5	813-0165	Elbow, ½", 90° Street
6	813-0265	Nipple, ½ x 2-½" NPT BM
7		Hose, Heated Oil Return
	810-0945	120VAC
	810-1037	208-250VAC
8	810-1159	Flexline, Steel, 5" Oil Return (Pump to Filter Pan Outlet)
9	810-1423	Hose, Teflon w/Stainless Braiding, 30" (from pump)
10	806-6728SP	Pump Wiring Assembly
11	810-1668	Adapter, Male 5/8 x ½" (Not Included With ½" Flexlines)
*	810-1669	Adapter, Female 5/8 x ½" (Not Included With ½" Flexlines)
12	810-1057	Flexline, 13" (39.5cm) Oil Return
13	810-1373	Flexline, Pump Bypass
14	813-0304	Bushing, Reducer- ½ to ¼"
15	813-0331	Elbow, ½" NPT With Side Outlet
16	813-0265	Nipple, ½" x 2-½" NPT BM
17	813-0530	Tee, Reducing- ½ x ¼ x ½" NPT BM
18	813-0537	Nipple, ¼ x 2" NPT BM
19	813-0543	Elbow, Street- ¼" x 90°
20	807-2484	Valve, Solenoid Vent
*	816-0093	Gasket, Pump Motor
*	807-1600	Thermal Switch, Baldor Motors
*	807-1598	Thermal Switch, Magnatek Motors
*	810-1421	Cable, Filter, FP47 (FPIII Units Equipped With Solenoid Valves)
*	807-2172	Cable, Filter, FP47 (FPIII Units With Heated Oil Return Hoses)
*	900-5673	Shield, Heat, FP47
* Not Illustrated		

**47 SERIES GAS FRYERS
CHAPTER 2: PARTS LIST**

2.13 Filter Pan Assembly- FootPrint III Series

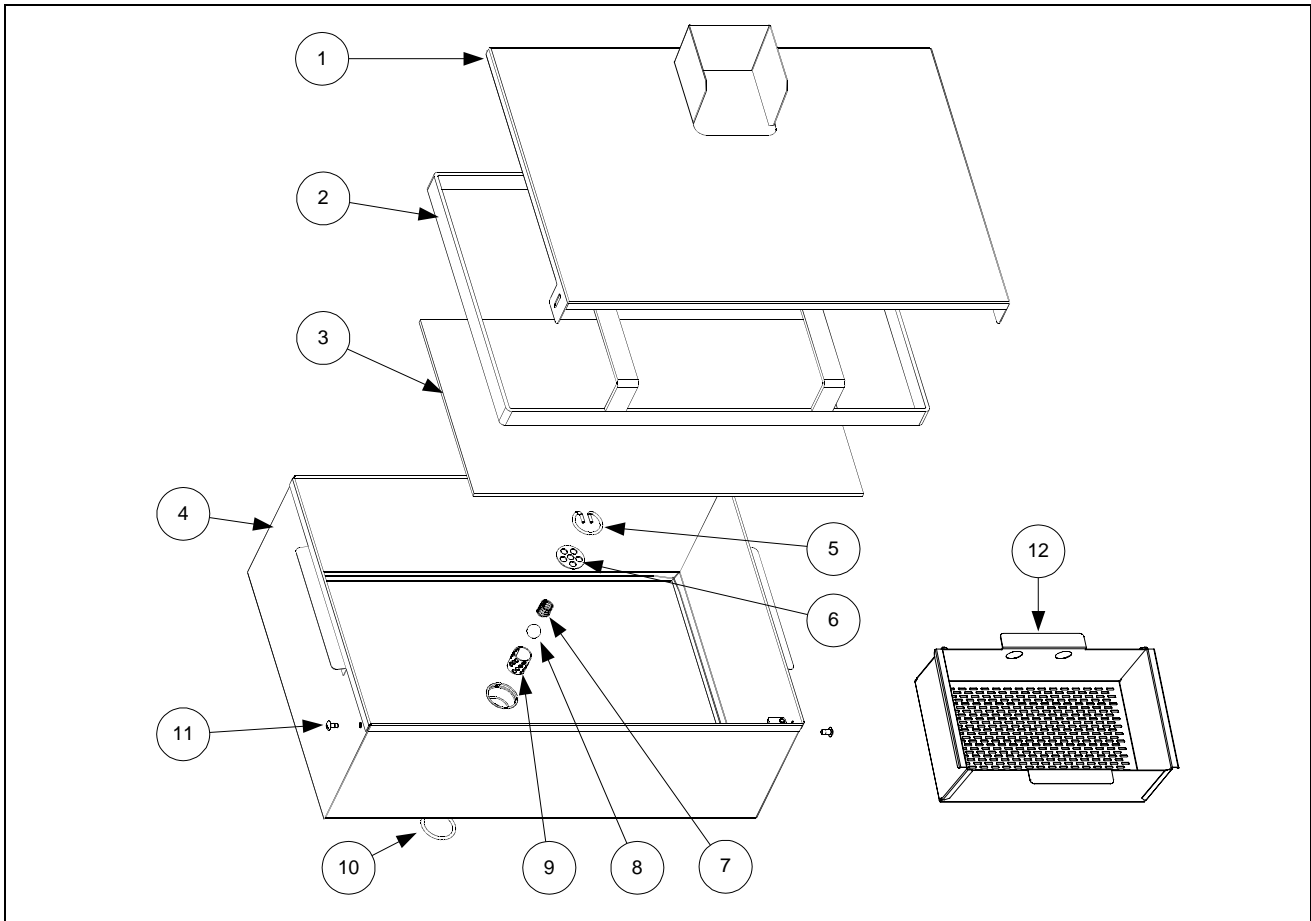

ITEM	PART #	COMPONENT
1	823-2027	Cover, Filter Pan
2	810-1408	Ring, Hold-Down
3	900-8819	Screen
4	823-1979SP	Pan
5	810-1387	Retainer, Check Valve
6	900-5448	Strain Plate, Check Valve
7	810-0946	Spring, Check Valve
8	810-0948	Ball, Check Valve
9	810-1388	Tube, Check Valve
10	816-0181	O-Ring, Check Valve
11	809-0422	Screw, Shoulder
12	824-0430	Screen, Crumb
*	806-5618SP	Pan Assembly, Complete (Crumb Screen Not Included)
*	803-0170	Paper, Filter- 100 Sheet Pack

* Not Illustrated

**47 SERIES GAS FRYERS
CHAPTER 2: PARTS LIST**

2.14 Oil Return Manifolds and Related Components

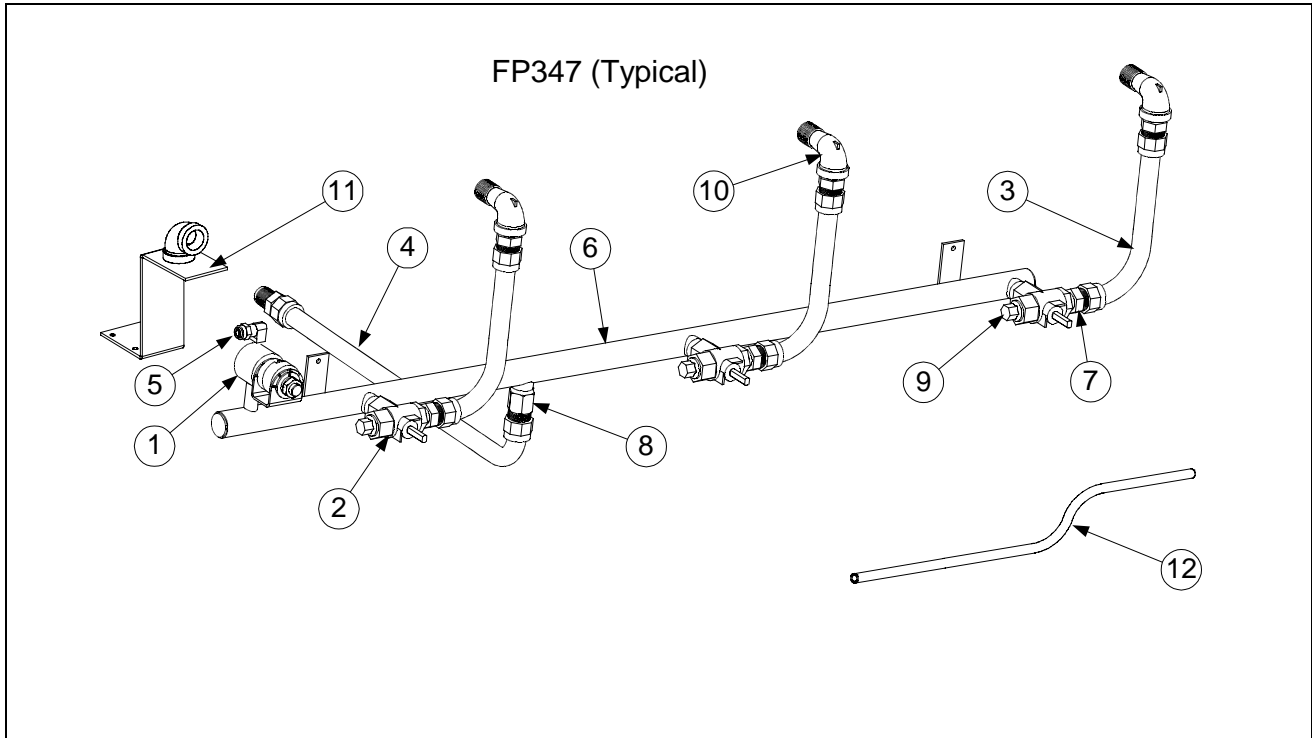

ITEM	PART #	COMPONENT
1	807-2484	Valve, Vent, Solenoid, ¼" NPT (for use on manifold and pump)
2	810-1003	Valve, Ball 3-Way, 180°
3	810-1067	Flexline, Dormont ½ x 8-½"
4	810-1369	Flexline, Dormont, ½ x 17-½" (filter to manifold)
*	810-1370	Flexline, Dormont, ½ x 9" (to Power Shower)
5	810-1372	Fitting, 90° (for use with Teflon vent tube P/N 826-1720)
6		Manifold, FP47 Power Shower Oil Return
	810-1394	Manifold, FP347
*	810-1362	Manifold, FP247
*	810-1395	Manifold, FP447
7	810-1668	Adapter, Male 5/8 x ½" (For ½" I.D. Flexlines)
8	810-1669	Adapter, Female 5/8 x ½" (For ½" I.D. Flexlines)
9	813-0156	Plug, ½" Hex Head NPT BM
10	813-0165	Elbow, Street- 90° NPT BM
11	823-2583	Support, Oil Return, FP47
12	826-1720	Teflon Vent Tube Kit (Solenoid to Square-Drain Vent)

* Not Illustrated

**47 SERIES GAS FRYERS
CHAPTER 2: PARTS LIST**

2.15 Oil Return Valve Assembly

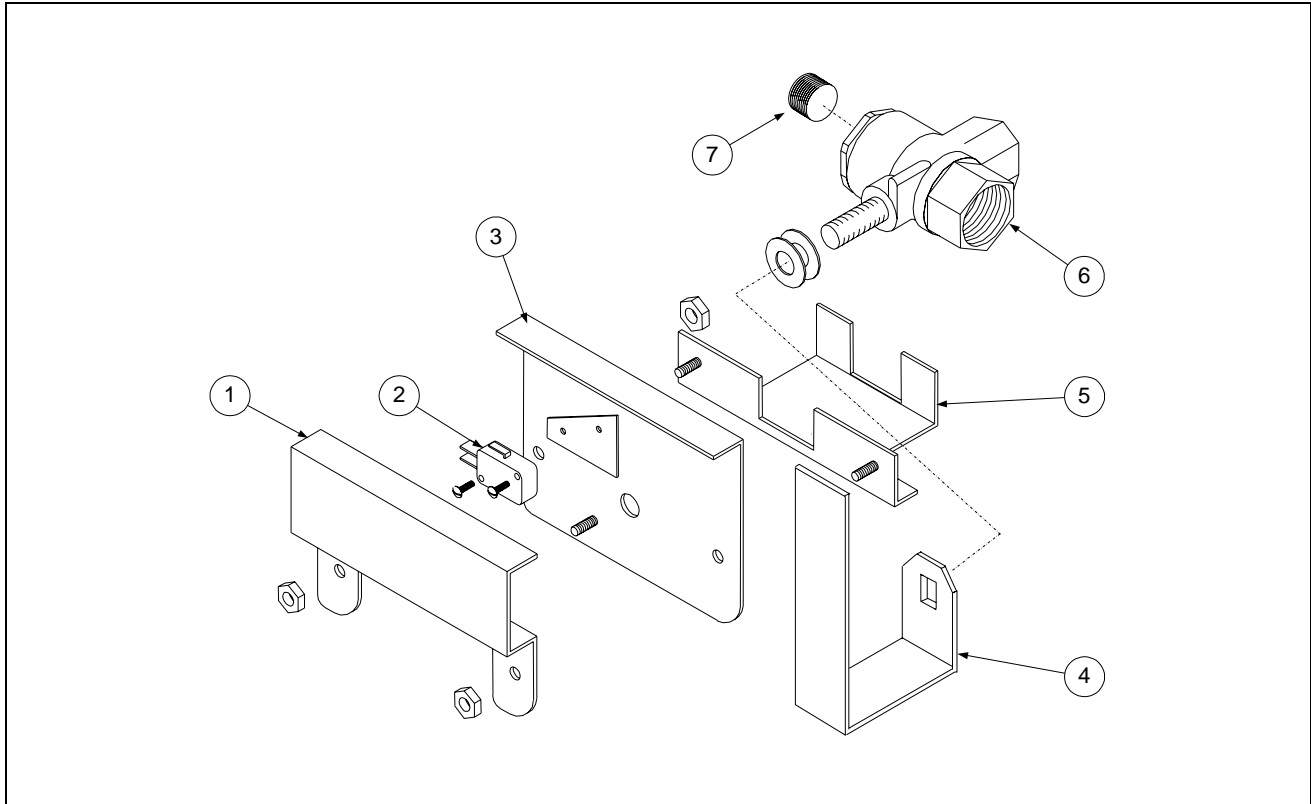

ITEM	PART #	COMPONENT
1	900-2110	Cover, Microswitch
2	807-2104	Microswitch
3	806-9385	Support, Microswitch
4	900-1950	Handle, Oil Return
5	900-2111SP	Support, Oil Return Valve
6	810-1003	Valve, 180° 3-Way Ball
7	813-0463	Plug, Pipe, ½" NPT (Hex/Square Socket)

47 SERIES GAS FRYERS CHAPTER 2: PARTS LIST

2.16 Drain Manifold Assembly and Related Components

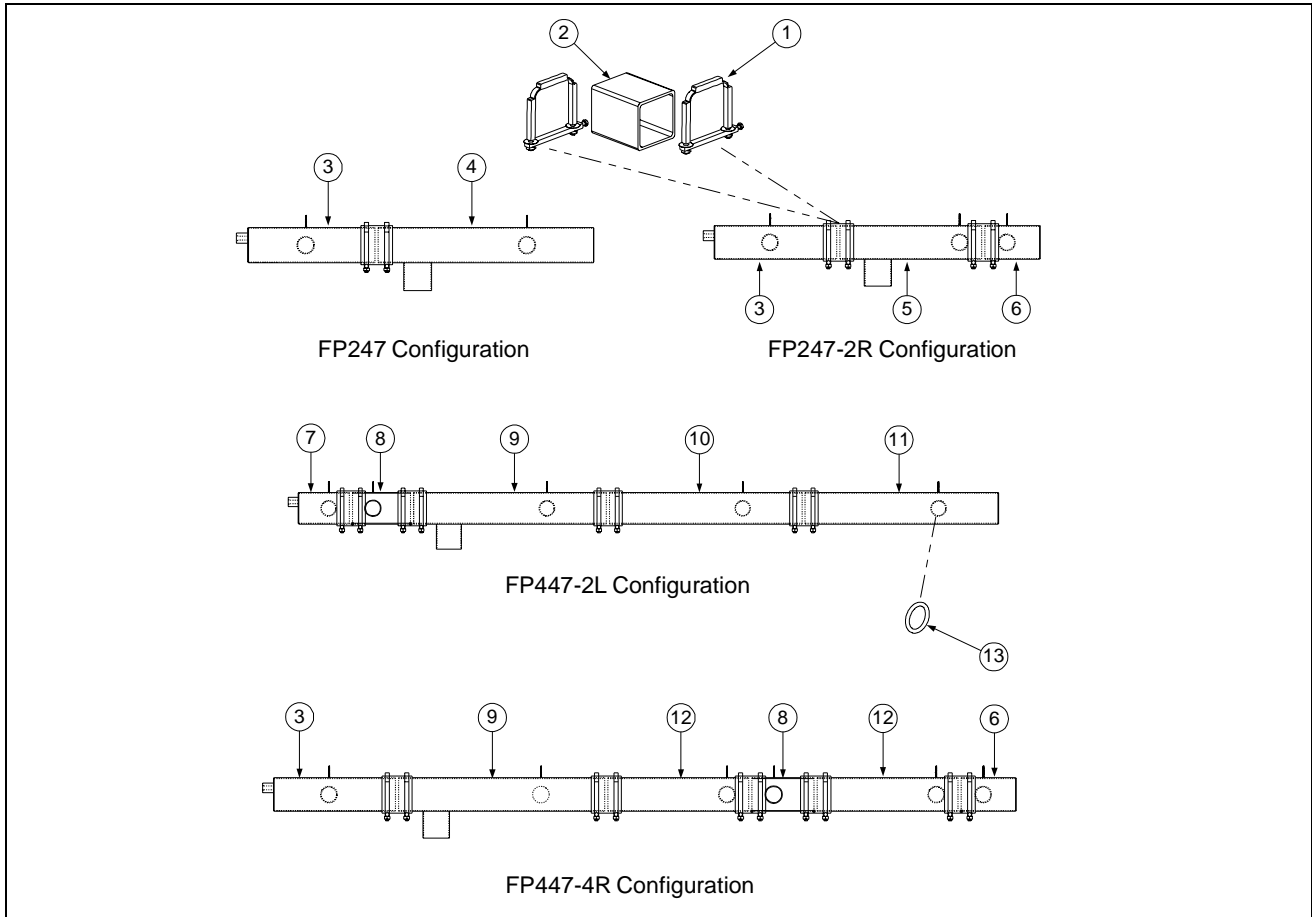

ITEM	PART #	COMPONENT
1	806-6374SP	Clamp Assembly
2	816-0420	Seal (Connection Gasket)
Drain Sections		
3	823-2585	End, Left, Long for Full Vat- Vented
*	823-2445	End, Left, Long for Full Vat (Old-Style FootPrint)
4	823-2242	Filter Pan Outlet (closed) for Full Vat
5	823-2239	Filter Pan Outlet (open) for Dual Vat
6	823-2244	End, Right, Short for Dual Vat-Right
7	823-2584	End, Left, Short for Dual Vat-Vented
*	823-2237	End, Left, Short for Dual Vat- (Old-Style FootPrint)
8	823-2238	Section, Short for Dual Vat
9	823-2245	Filter Pan Outlet (open) for Full Vat
10	823-2246	Section, Long for Full Vat
11	823-2240	End, Right, Long for Full Vat
12	823-2241	Section, Long for Dual Vat
13	816-0135	O-Ring

* Not Illustrated

**47 SERIES GAS FRYERS
CHAPTER 2: PARTS LIST**

2.17 Filter Component Box Assemblies

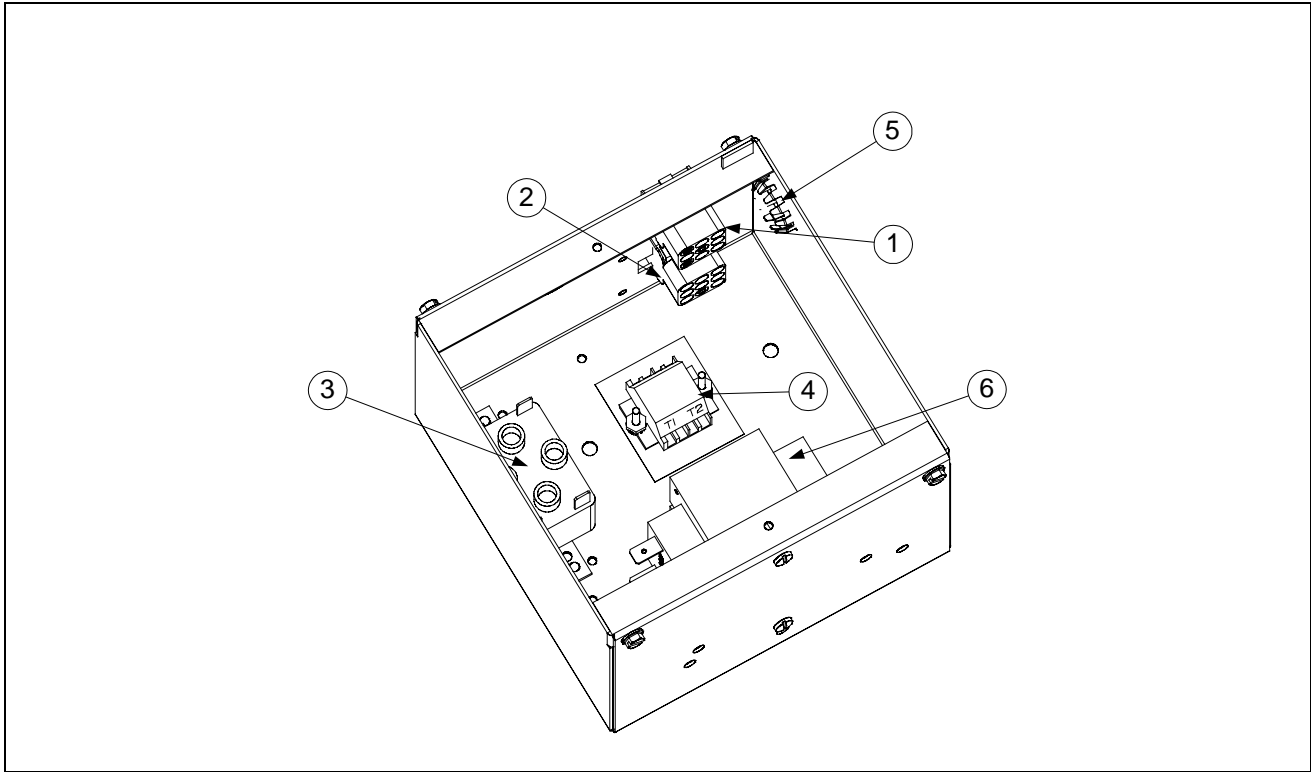

ITEM	PART #	COMPONENT
		Complete Assemblies
	806-8358SP	100-120V Replacement Filter Box Assembly
	806-8359SP	208-250V Replacement Filter Box Assembly
		Components
1	806-8021SP	Plug Assembly, FP III Non-Reversing (Upper Plug)
2	806-7494SP	Plug Assembly, FP III Non-Reversing (Lower Plug)
3	807-0012	Relay, 18 Amp, 1/3 HP, 24V Coil (4-Pole)
*	807-2434	Relay, 18 Amp, 1/3 HP, 24V Coil (5-Pole)
4	810-1164	Block, 1-Piece Screwless Terminal
5	810-0044	Plug Button
6		Transformer, V & F, Dual Voltage
	807-2176	100V-120V
	807-1999	208V-240V
*	806-9824	Wiring Assembly- Australia Only

* Not Illustrated

47 SERIES GAS FRYERS
CHAPTER 2: PARTS LIST

2.18 Flue Assemblies and Related Components

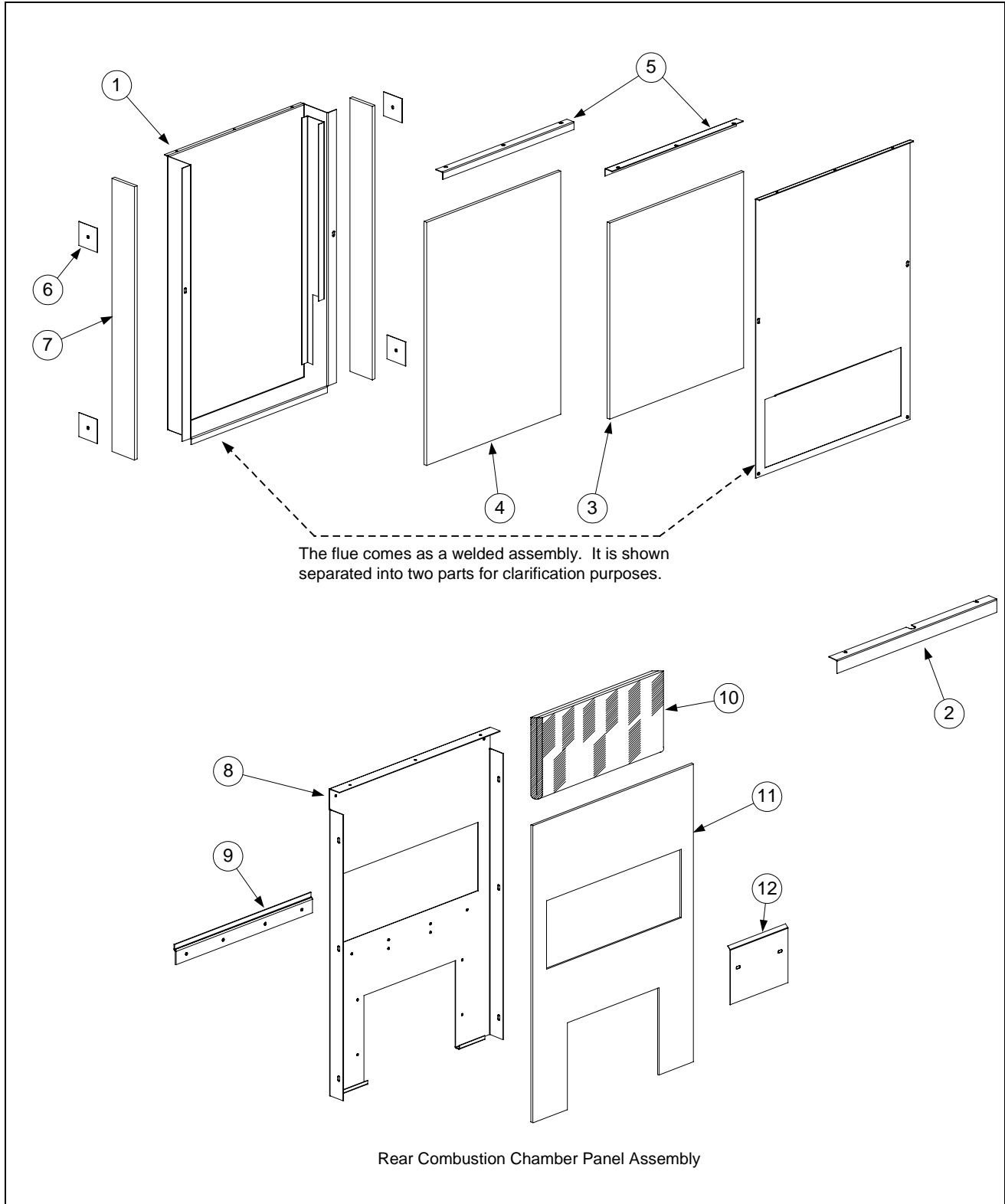

**47 SERIES GAS FRYERS
CHAPTER 2: PARTS LIST**

ITEM	PART #	COMPONENT
1	823-2018	Flue Weld Assembly (No Insulation, Retainers, etc.)
*	806-5567SP	Flue Assembly (Includes Insulation, Retainers, etc.)
2	900-4253	Strip, Flue Cap Retainer
3	816-0175	Insulation, Flue- Front
4	816-0174	Insulation, Flue- Rear
5	900-4664	Retainer, Flue- Top Insulation
6	930-0474	Retainer, Flue- Side Insulation
7	812-0256	Insulation, Flue- Side
Rear Combustion Chamber Components		
8	900-7553	Panel, Rear Combustion Chamber
*	806-5566	Panel Assembly, Rear Combustion Chamber
9	900-3420	Support, Flue- Back
10	812-0269	Insulation, Kaowool Blanket- ½ x 14 x 14"
11	816-0178	Insulation, Rear Combustion Chamber
12	900-0412	Retainer, Insulation
* Not Illustrated		

47 SERIES GAS FRYERS
CHAPTER 2: PARTS LIST

2.19 Frypot Assemblies and Related Components

2.19.1 Frypot Components — Full-Vat

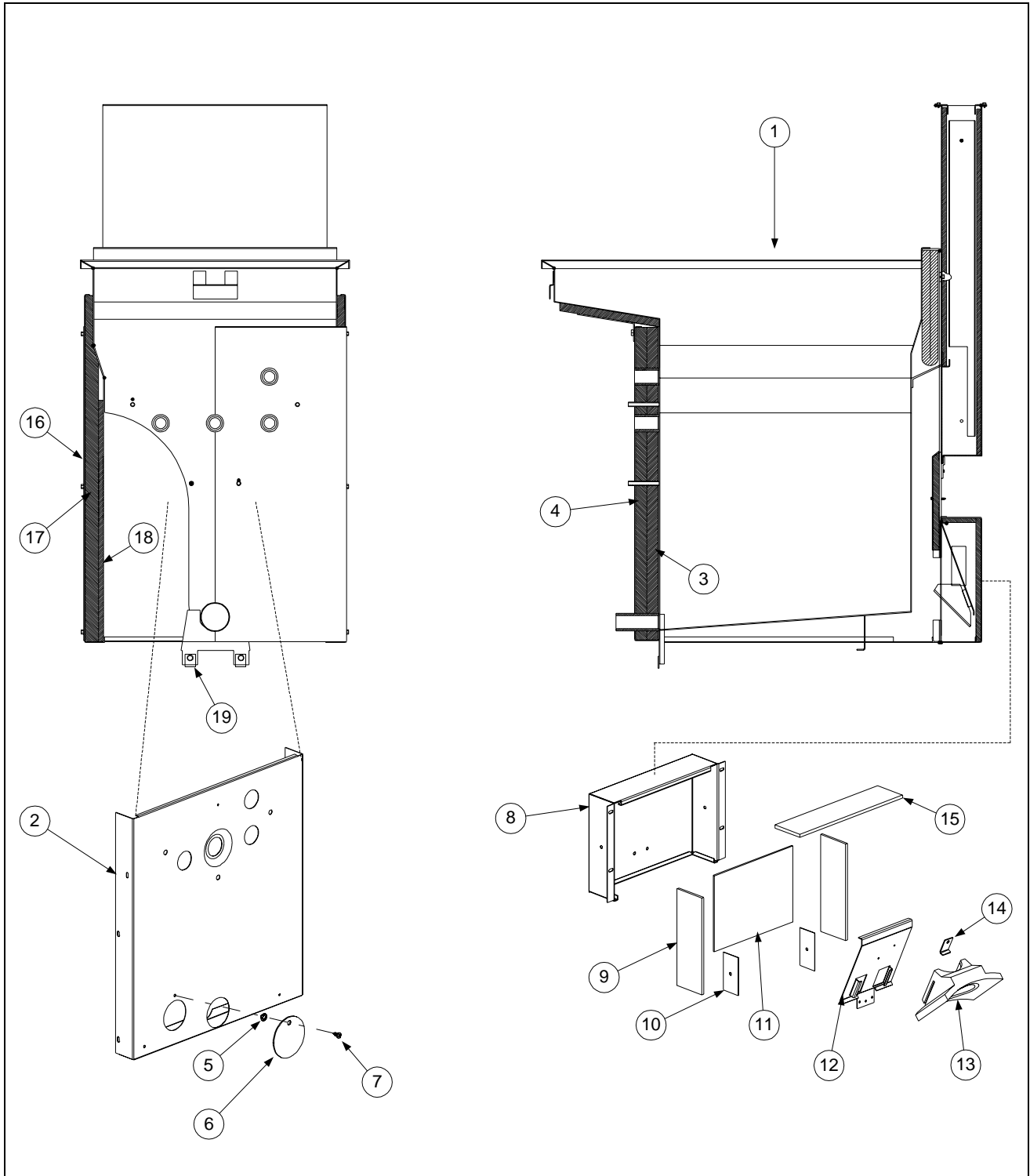

**47 SERIES GAS FRYERS
CHAPTER 2: PARTS LIST**

ITEM	PART #	COMPONENT
1	106-1625SP	Frypot Assembly, Full Vat, Power Shower, Complete
*	823-3462SP	Frypot, Full Vat (Insulation and Flue Assembly NOT INCLUDED)
		Front Combustion Chamber Components
2	930-3419	Baffle, Outer Front
3	812-0246	Insulation, Inner Layer
4	812-0245	Insulation, Outer Layer
5	810-0647	Holder, Security Screw
6	900-1090	Cover, Pilot View Port
7	809-0409	Screw, Security
*	806-1095SP	Front Combustion Chamber Assembly (Items 2-7)
		Flue Deflector Box Components
8	900-4685	Box, Flue Deflector
9	816-0171	Insulation, Side
10	900-0169	Retainer, Insulation
11	816-0173	Insulation, Rear
12	910-2030	Holder, Target
13	810-0424	Deflector, Rear Burner
14	910-2068	Clip, Rear Target
15	816-0172	Insulation, Top
*	806-5778SP	Box Assembly, Flue Deflector (Items 8-15)
		Other Components
16	900-6441	Panel, Combustion Chamber Side
17	812-0249	Insulation, Side, Outer Layer, 1 x 16- ³ / ₄ x 19.38"
18	812-0248	Insulation, Side, Inner Layer, ¹ / ₄ x 14- ¹ / ₂ x 15.93", Kaowool
19	809-0173	Clip, Tinnerman
* Not Illustrated		

47 SERIES GAS FRYERS
CHAPTER 2: PARTS LIST

2.19.2 Frypot Components — Dual-Vat

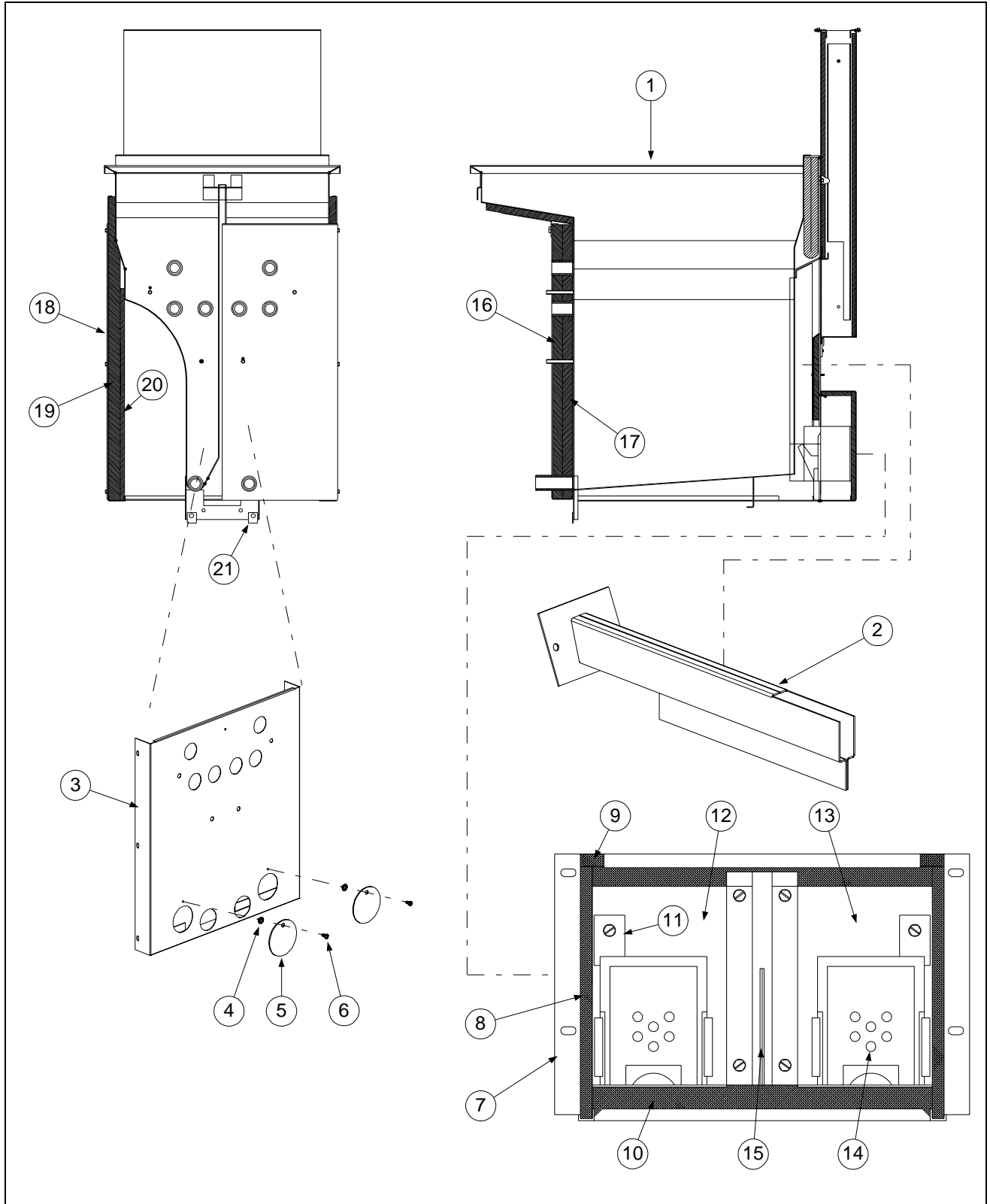

**47 SERIES GAS FRYERS
CHAPTER 2: PARTS LIST**

ITEM	PART #	COMPONENT
1	106-1624SP	Frypot Assembly, Dual Vat, Power Shower, Complete
*	823-3460SP	Frypot, Dual Vat, (Insulation and Flue Assembly NOT INCLUDED)
2	823-2016	Divider, Upper Combustion Chamber
3	900-4675	Panel, Front Combustion Chamber
4	810-0647	Holder, Security Screw
5	900-1090	Cover, Pilot View Port
6	809-0409	Screw, Security
Flue Deflector Box Components		
7	900-4685	Box, Flue Deflector
8	816-0171	Insulation, Side
9	816-0172	Insulation, Top Edge
10	816-0173	Insulation, Back
11	910-2068	Clip, Rear Target
12	911-2059	Holder, Target, Left
13	912-2059	Holder, Target, Right
14	814-0034	Target, Ceramic
15	823-2015	Divider, Lower
*	806-5779SP	Box Assembly, Flue Deflector (Items 7-15)
Other Components		
16	816-0176	Insulation, Front, Outer Layer, Spinal Glass
17	816-0177	Insulation, Front, Inner Layer, Kaowool
18	900-6441	Panel, Combustion Chamber Side
19	812-0249	Insulation, Side, Outer Layer, 1 x 16- ³ / ₄ x 19.38"
20	812-0248	Insulation, Side, Inner Layer, 1/4 x 14-1/2 x 15.93", Kaowool
21	809-0173	Clip, Tinnerman
* Not Illustrated		

**47 SERIES GAS FRYERS
CHAPTER 2: PARTS LIST**

2.20 Power Shower Components

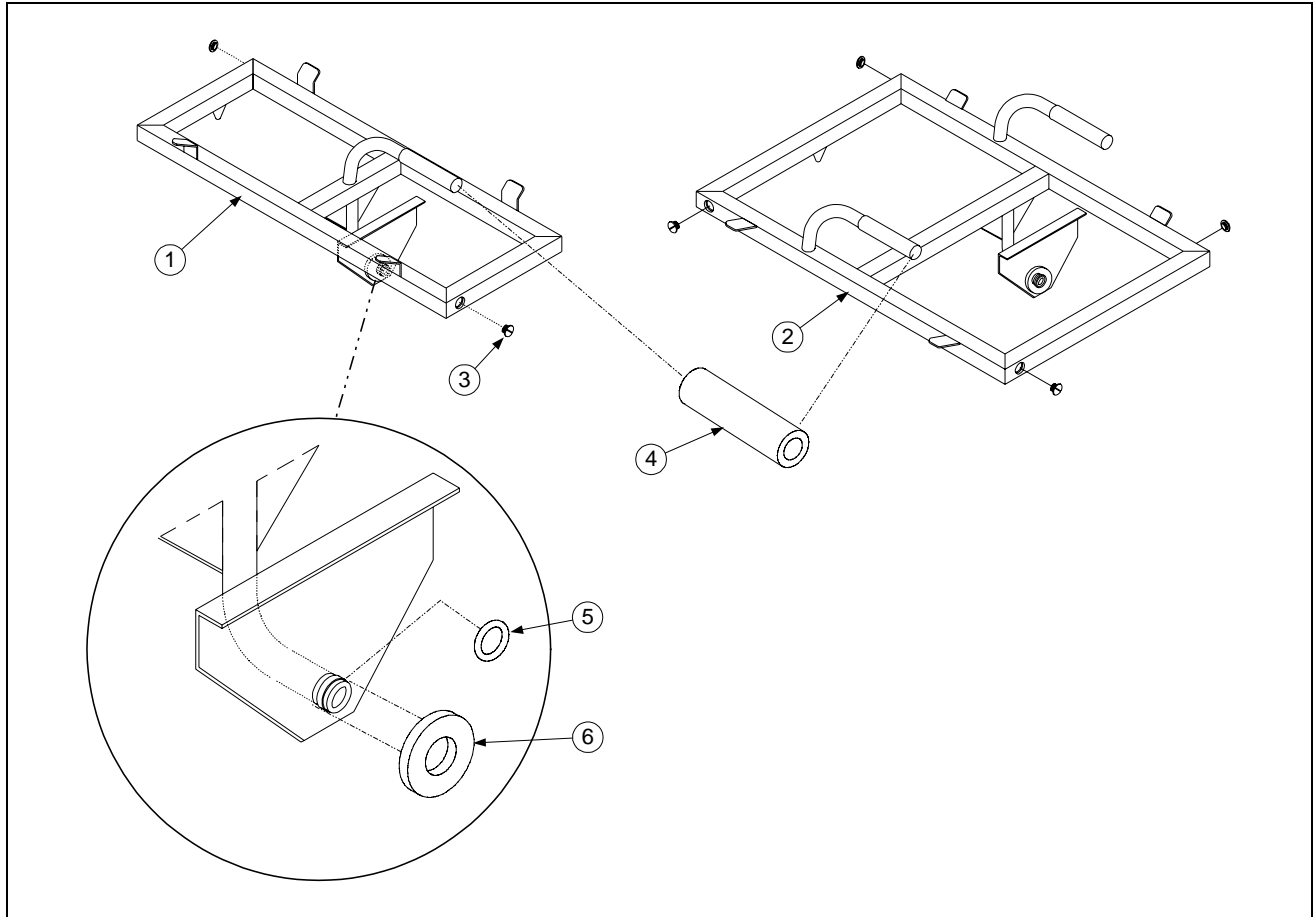

ITEM	PART #	COMPONENT
1	806-6302SP	Power Shower Assembly, Dual Vat, Complete
2	806-4503SP	Power Shower Assembly, Full Vat, Complete
3	809-0415	Screw, Cleanout
4	814-0001	Grip, Handle
5	826-1344	O-Ring (Qty: 5)
6	826-1390	Seal (Gasket— Qty: 5)

**47 SERIES GAS FRYERS
CHAPTER 2: PARTS LIST**

2.21 Drain Valve Components

2.21.1 Full-Vat Drain Valve Components

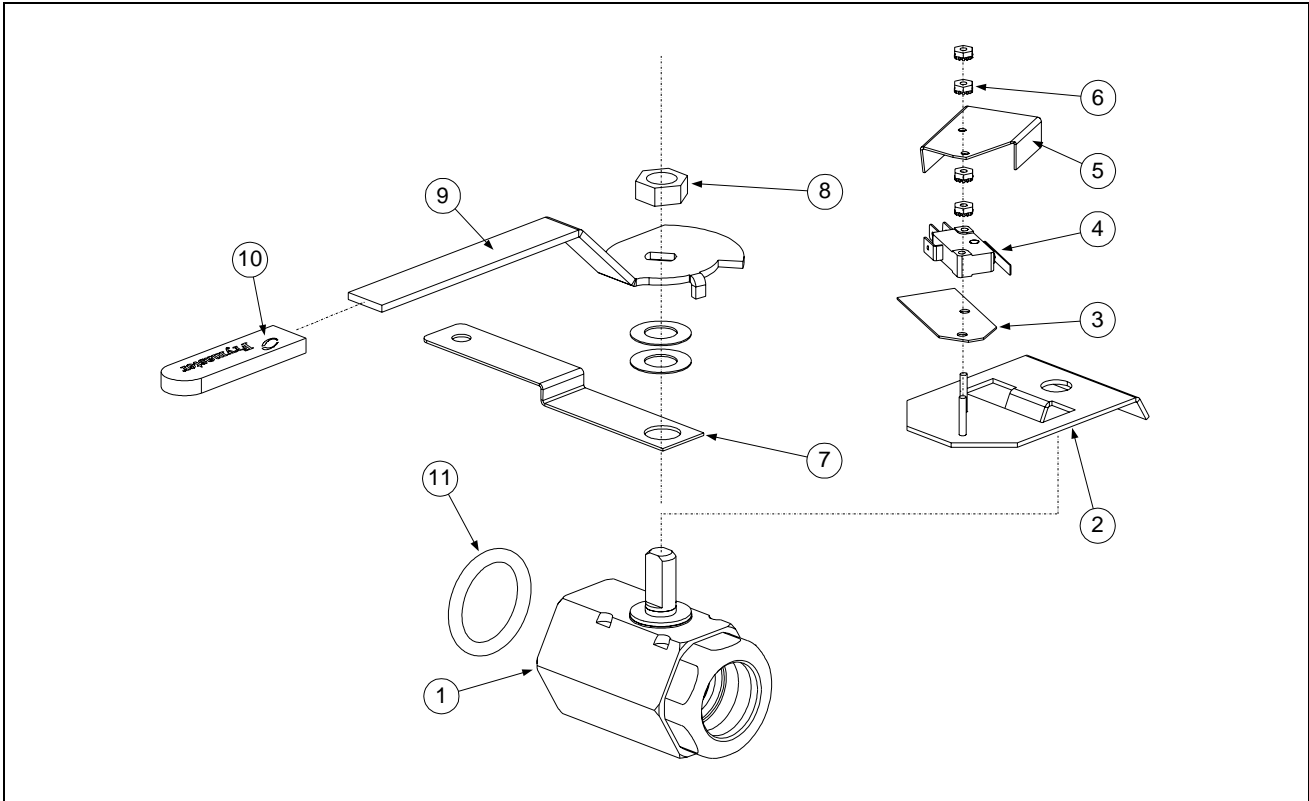

ITEM	PART #	COMPONENT
	806-7508SP	Drain Valve Assembly, Full Vat, 1 ¼", Complete, Filter Units
1	810-1018	Valve, w/o Handle
2	806-8137	Bracket, Drain Safety Microswitch
3	816-0220	Insulation, RF Switch
4	807-2103	Microswitch, Drain Safety
5	900-2841	Cover, Drain Safety Microswitch
6	826-1366	Nut, Hex Keps 4-40 (Qty: 25)
7	900-2354	Bracket, Drain Valve, 1 ¼"
8	809-0540	Nut, 2-Way Lock, ½" – 13
9	900-2521	Handle, Drain Valve
10	814-0047	Sleeve, Valve Handle, Red, w/Logo
11	816-0135	O-Ring
*	810-1569	Drain Valve, Full Vat, 1 ¼", Non-Filter Units (Includes Handle)
*	900-2936	Retainer, Full Vat Drain Valve
*	810-1427	Handle, Drain Valve- Non-Filter Units (One-Hand Locking)

* Not Illustrated

47 SERIES GAS FRYERS CHAPTER 2: PARTS LIST

2.21.2 Dual-Vat Drain Valve Components

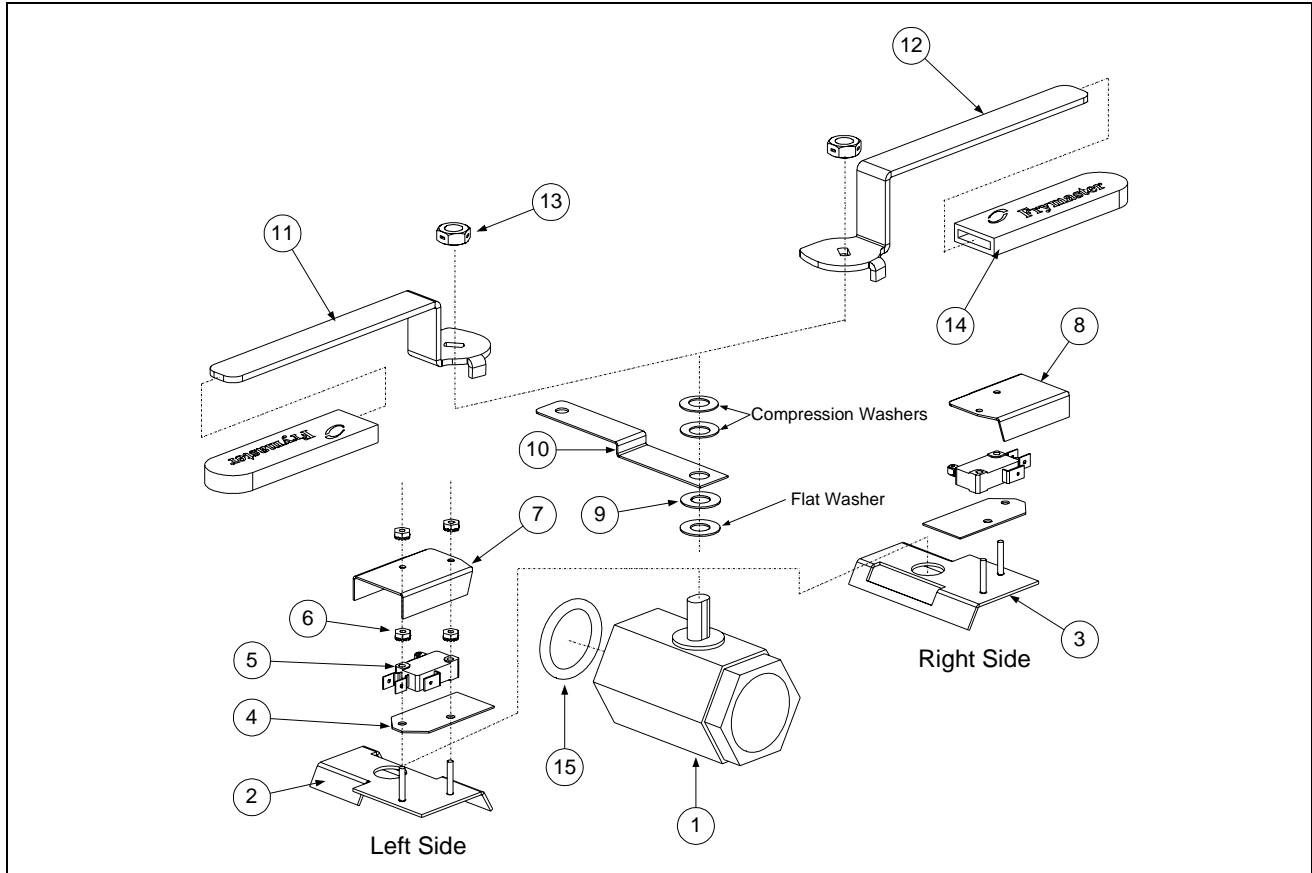

**47 SERIES GAS FRYERS
CHAPTER 2: PARTS LIST**

ITEM	PART #	COMPONENT
	806-7507SP	Drain Valve Assembly, Dual Vat, Left, 1", Complete, Filter Units
	806-7506SP	Drain Valve Assembly, Dual Vat, Right, 1", Complete, Filter Units
1	810-1114	Valve, Without Handle
2	806-8194	Bracket, Drain Safety Microswitch- Left Side
3	806-8195	Bracket, Drain Safety Microswitch- Right Side
4	816-0220	Insulation, RF Switch
5	807-2104	Microswitch, Drain Safety
6	826-1366	Nut, Hex Keps 4-40 (Qty: 25)
7	901-2348	Cover, Drain Safety Microswitch- Left Side
8	902-2348	Cover, Drain Safety Microswitch- Right Side
9	810-1165	Washer, Teflon
10	900-2355	Bracket, Drain Valve, 1"
11	900-2509	Handle- Left Side
12	900-2503	Handle- Right Side
13	809-0539	Nut, 2-Way Lock- 3/8-16
14	814-0047	Sleeve, Valve Handle, Red, w/Logo
15	816-0135	O-Ring
*	810-1338	Drain Valve, Dual Vat, Left or Right, 1", Non-Filter Units
*	900-2934	Retainer, Dual Vat Drain Valve
*	806-9062	Handle, Left Drain Valve
*	806-9064	Handle, Right Drain Valve

* Not Illustrated

47 SERIES GAS FRYERS CHAPTER 2: PARTS LIST

2.22 Modular Basket Lift Components

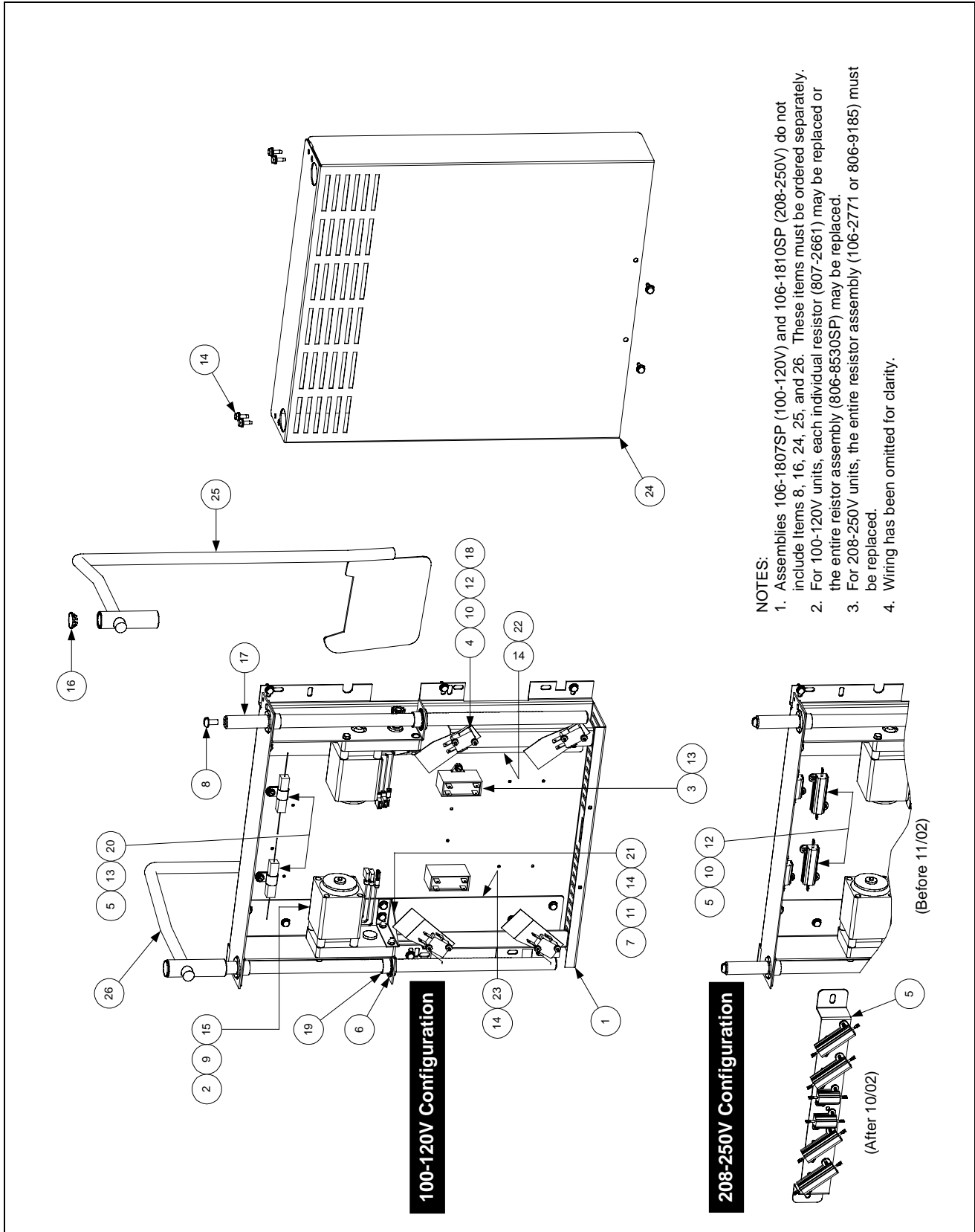

**47 SERIES GAS FRYERS
CHAPTER 2: PARTS LIST**

ITEM	PART #	COMPONENT
1		Mount, Modular Basket Lift**
	200-2942	For use on units with 12-pin connectors
	900-7655	For use on units with 6-pin connectors
2	806-5964SP	Motor Assembly, Modular Basket Lift
3	807-2133	Capacitor, 12.5 μ Farad, 250VAC Motor Run
4	807-2572	Microswitch
5		Resistor Assembly
	806-8530SP	100-120V Modular Basket Lift (see Note 2 in illustration)
	106-2771	208-250V Modular Basket Lift (before 11/02 use 806-9185; see Note 3)
6	809-0082	Ring, Truarc Retaining
7	826-1361	Screw, 2-32 X 1-inch Slotted Truss Head (Pkg. of 25)
8	809-0127	Screw, ¼-20 X ½-inch Slotted Round Head
9	809-0186	Lock Washer w/External Teeth, #8
10	826-1366	Nut, 4-40 Hex Keps (Pkg. of 25)
11	809-0247	Nut, 2-32 Hex Keps
12	826-1359	Screw, 4-40 X ¾-inch Slotted Round Head (Pkg. of 25)
13	826-1371	Screw, #8 X ½-inch Hex Head Drill Point (Pkg. of 25)
14	826-1374	Screw, #10 X ½-inch Hex Head (Pkg. of 25)
15	809-0503	Screw, 2-32 X ½-inch Hex Head
16	810-0172	Plug, ⅝-inch Stainless Steel Hole
17	810-1012	Rod, Modular Basket Lift
18	812-0442	Insulation, Microswitch
19	813-0035	Bushing, Bronze, .640" ID
20	816-0033	Tie Wrap, Screw Mount
21	900-5529	Gusset, Modular Basket Lift Motor
22	901-8499	Chassis, Modular Basket Lift, Left
23	902-8499	Chassis, Modular Basket Lift, Right
24	910-4776	Cover, Modular Basket Lift
25	823-06931	Rod Assembly, Left Basket Lift
26	823-06932	Rod Assembly, Right Basket Lift
*		Connector, Panel Mount**
	807-0159	12-pin
	807-0158	6-pin
		Wire Assemblies**
*	806-9014SP	For 100-120V Modular Basket Lift w/6-Pin Connector
*	806-8555SP	For 202-250V Modular Basket Lift w/6-Pin Connector
*	106-1822SP	For 100-120V Modular Basket Lift w/12-Pin Connector
*	106-1804SP	For 202-250V Modular Basket Lift w/12-Pin Connector
		Complete Basket Lift Assemblies (see Note 1 in illustration)
*	106-1807SP	100-120V w/o Relay
*	106-1810SP	202-250V w/o Relay

* Not illustrated.

** Basket lift assemblies manufactured prior to February 2002 have 6-pin connectors; those manufactured February 2002 and later have 12-pin connectors. Verify the type of connector in use before ordering wiring assemblies or mounts.

**47 SERIES GAS FRYERS
CHAPTER 2: PARTS LIST**

2.23 Gas Conversion Kits

ITEM	PART #	COMPONENT
	826-1143	Natural Gas to Propane, Honeywell (Non-CE)
	826-1144	Propane to Natural Gas, Honeywell (Non-CE)
	826-0962	Natural Gas to Propane, Robert Shaw (Non-CE)
	826-0963	Propane to Natural Gas, Robert Shaw (Non-CE)
	826-1462	Natural Gas to Propane, Full Vat, Complete (CE Only)
	826-1464	Natural Gas to Propane, Dual Vat, Complete (CE Only)
	826-1463	Propane to Natural Gas, Full Vat, Complete (CE Only)
	826-1465	Propane to Natural Gas, Dual Vat, Complete (CE Only)
		Honeywell- Electronic Ignition – Natural to Propane Components
	807-1848	Spring Kit, Gas Valve
	826-1387	Orifice, Burner (Qty: 10)
	807-1708	Ignitor/Pilot Assembly
NOTE: Each kit contains a pilot with thermopile, the appropriate number and sizes of orifices, and a gas valve regulator.		



FRYMASTER
8700 LINE AVENUE, SHREVEPORT, LA 71106-6800

800-551-8633
318-865-1711

WWW.FRYMASTER.COM

EMAIL: FRYSERVICE@WELBILT.COM



Welbilt offers fully-integrated kitchen systems and our products are backed by KitchenCare® aftermarket parts and service. Welbilt's portfolio of award-winning brands includes Cleveland™, Convotharm®, Crem®, Delfield®, Frymaster®, Garland®, Kolpak®, Lincoln®, Merco®, Merrychef® and Multiplex®.

Bringing innovation to the table • welbilt.com

©2022 Welbilt Inc. except where explicitly stated otherwise. All rights reserved. Continuing product improvement may necessitate change of specifications without notice.

Part Number FRY_SP_8195384 08/2022