

**SERVICE MANUAL
FRYMASTER H14 SERIES
ELECTRIC FRYER**

This equipment chapter is to be installed in the Fryer Section of the *Equipment Manual*.

FOR YOUR SAFETY
Do Not Store or use gasoline or other flammable vapors and liquids in the vicinity of this or any other appliance.

**MANUFACTURED
BY**



**8700 LINE AVENUE
SHREVEPORT, LOUISIANA 71106
PHONE: 1-318-865-1711
TOLL FREE: 1-800-551-8633
1-800-24 FRYER**



TABLE OF CONTENTS

WARRANTY STATEMENT Page i
 INTRODUCTION..... Page 1-1
 INSTALLATION INSTRUCTIONS Page 2-1
 OPERATING FRYERS WITH M100B COOKING COMPUTERS Page 3-1
 OPERATING FRYERS WITH THERMOSTAT CONTROLLERS Page 4-1
 OPERATING THE BUILT-IN FILTRATION SYSTEM..... Page 5-1
 PREVENTIVE MAINTENANCE AND TROUBLESHOOTING Page 6-1
 SERVICE PROCEDURES AND WIRING DIAGRAMS..... Page 7-1
 PARTS LIST Page 8-1

The Frymaster Corporation
8700 Line Avenue
Shreveport, Louisiana 71106
PHONE 318-865-1711

PRINTED IN THE UNITED STATES

SERVICE HOTLINE 1-800-24-FRYER

09/2022



WARNING

IMPROPER INSTALLATION, ADJUSTMENT, ALTERATION, SERVICE OR MAINTENANCE CAN CAUSE PROPERTY DAMAGE, INJURY OR DEATH. READ THE INSTALLATION, OPERATING AND MAINTENANCE INSTRUCTIONS THOROUGHLY BEFORE INSTALLING OR SERVICING THIS EQUIPMENT.

WARNING

FOR YOUR SAFETY, DO NOT STORE OR USE GASOLINE OR OTHER FLAMMABLE VAPORS AND LIQUIDS IN THE VICINITY OF THIS OR ANY OTHER APPLIANCE.

COMPUTERS

FCC

This device complies with Part 15 of the FCC rules. Operation is subject to the following two conditions: 1) This device may not cause harmful interference, and 2) This device must accept any interference received, including interference that may cause undesired operation. While this device is a verified Class A device, it has been shown to meet the Class B limits

CANADA

This digital apparatus does not exceed the Class A or B limits for radio noise emissions as set out by the ICES-003 standard of the Canadian Department of Communications.

Cet appareil numerique n'emet pas de bruits radioelectriques depassant les limites de classe a et b prescrites dans la norme NMB-003 edictee par le ministre des communications du Canada.

WARNING

THIS PRODUCT CONTAINS CHEMICALS KNOWN TO THE STATE OF CALIFORNIA TO CAUSE CANCER AND/OR BIRTH DEFECTS OR OTHER REPRODUCTIVE HARM.

Operation, installation and servicing of this product could expose you to airborne particles of glasswool or ceramic fibers, crystalline silica, and/or carbon monoxide. Inhalation of airborne particles of glasswool or ceramic fibers is known to the State of California to cause cancer. Inhalation of carbon monoxide is known to the State of California to cause birth defects or other reproductive harm.

FRYMASTER ELECTRIC FRYERS ARE MANUFACTURED FOR USE WITH THE TYPE VOLTAGE SPECIFIED ON THE FRYER RATING PLATE LOCATED ON THE FRYER DOOR. FOR PROPER INSTALLATION PROCEDURES IN THE UNITED STATES, REFER TO THE LATEST EDITION OF THE NATIONAL ELECTRIC CODE ANSI/N.F.P.A. NO. 70; IN CANADA, CANADIAN ELECTRICAL CODE PART 1, CSA-22.1. FOR INSTALLATION IN COUNTRIES OTHER THAN THE UNITED STATES AND CANADA, REFER TO THE NATIONAL CODE APPROPRIATE FOR THE COUNTRY IN WHICH THE EQUIPMENT IS BEING INSTALLED.

INFORMATION ON THE CONSTRUCTION AND INSTALLATION OF VENTILATING HOODS MAY BE OBTAINED FROM THE LATEST EDITION OF THE "STANDARD FOR THE INSTALLATION OF EQUIPMENT FOR THE REMOVAL OF SMOKE AND GREASE LADEN VAPORS FROM COMMERCIAL COOKING EQUIPMENT," N.F.P.A. NO. 96. COPIES OF THESE ELECTRICAL STANDARDS ARE AVAILABLE FROM THE NATIONAL FIRE PROTECTION ASSOCIATION, BATTERY MARCH PARK, QUINCY, MASS. 02269

WARRANTY STATEMENT

Frymaster, L.L.C. makes the following limited warranties to the original purchaser only for this equipment and replacement parts:

A. WARRANTY PROVISIONS - FRYERS

1. The Frymaster Corporation warrants all components against defects in material and workmanship for a period of one year.
2. All parts, with the exception of the frypot, heating elements and fuses, are warranted for one year after installation date of fryer.
3. If any parts, except fuses, become defective during the first year after installation date, Frymaster will also pay straight-time labor costs to replace the part, plus up to 100 miles/160 km of travel (50 miles/80 km each way).

B. WARRANTY PROVISIONS - FRYPOTS

(Applies to fryers installed on or after January 1, 1995, only.)

If a frypot develops a leak within seven years after installation, Frymaster will, at its option, either replace the entire battery or replace the frypot, allowing up to the maximum time per the Frymaster time allowance chart hours of straight-time labor plus up to 100 miles/160 km of travel (50 miles/80 km each way) to change the frypot.

C. WARRANTY PROVISIONS - HEATING ELEMENTS

(Applies to fryers installed on or after January 1, 1995, only.)

1. The Frymaster Corporation warrants the heating elements against defective material or workmanship for a period of three years from the original installation date, parts only.
2. This warranty does not cover ancillary components, including the hi-limit, temperature probe, and contactors.

D. WARRANTY PROVISIONS - COOKING COMPUTER

1. The Frymaster Corporation warrants the M-100B Cooking Computer against defective material or workmanship for a period of one year from the original installation date, parts and labor. Replacements for defective units during the second and third year are available at a reduced rate.
2. During this warranty period, Frymaster will, at its option, repair or replace defective cooking computer returned with new or factory rebuilt and functionally operative units.

3. For replacement of defective computers under warranty, call your local Frymaster Factory Authorized Service Center. All computers replaced under the Frymaster exchange program are covered by a one-year (parts only) warranty.

E. PARTS RETURN

All defective in-warranty parts must be returned to a Frymaster Authorized Factory Service Center within 60 days for credit. After 60 days, no credit will be allowed.

F. WARRANTY EXCLUSIONS

This warranty does not cover equipment that has been damaged due to misuse, abuse, alteration, or accident such as:

- improper or unauthorized repair (including any frypot which is welded in the field);
- failure to follow proper installation instructions and/or scheduled maintenance procedures as prescribed in your MRC cards. Proof of scheduled maintenance is required to maintain the warranty;
- improper maintenance;
- damage in shipment;
- abnormal use;
- removal, alteration, or obliteration of either the rating plate or the date code on the heating elements;
- operating the frypot without shortening or other liquid in the frypot;
- no fryer will be warranted under the seven-year program for which a proper start-up form has not been received.

This warranty also does not cover:

- transportation or travel over 100 miles/160 km (50 miles/80 km each way), or travel over two hours;
- overtime or holiday charges;
- consequential damages (the cost of repairing or replacing other property which is damaged), loss of time, profits, use or any other incidental damages of any kind.

There are no implied warranties of merchantability or fitness for any particular use or purpose.

CHAPTER 1: INTRODUCTION

1.1 General

Read the instructions in this manual thoroughly before attempting to operate this equipment. This manual covers all configurations of models MH14 and BIMH14 fryers built since July 1999. Models designated MH14 do not have built-in filtration systems. Models designated BIH14 are equipped with FootPrint III built-in filtration systems.

H14 Series fryers feature deep cold-zones and easy to clean, open frypots with tilt-up elements. The fryers are controlled by multi-product cooking computers or optional thermostat controllers. Fryers in this series come in full or split-pot arrangements, and can be purchased as single units or grouped in batteries of up to five fryers.

1.2 Safety Information

Before attempting to operate your unit, read the instructions in this manual thoroughly.

Throughout this manual, you will find notations enclosed in double-bordered boxes similar to the ones below.

CAUTION boxes contain information about actions or conditions that *may cause or result in a malfunction of your system*.



WARNING boxes contain information about actions or conditions that *may cause or result in damage to your system*, and which may cause your system to malfunction.



DANGER boxes contain information about actions or conditions that *may cause or result in injury to personnel*, and which may cause damage to your system and/or cause your system to malfunction.



Fryers in this series are equipped with automatic safety features:

1. Two high temperature detection features shut off power to the elements should the controlling thermostat fail.
2. A safety switch built into the drain valve prevents the elements from heating with the drain valve even partially open.

1.3 Computer Information

This equipment has been tested and found to comply with the limits for a Class A digital device, pursuant to Part 15 of the FCC rules. While this device is a verified Class A device, it has been shown to meet the Class B limits. These limits are designed to provide reasonable protection against harmful interference when the equipment is operated in a commercial environment. This equipment generates, uses and can radiate radio frequency energy and, if not installed and used in accordance with the instruction manual, may cause harmful interference to radio communications. Operation of the equipment in a residential area is likely to cause harmful interference in which case the user will be required to correct the interference at his own expense.

The user is cautioned that any changes or modifications not expressly approved by the party responsible for compliance could void the user's authority to operate the equipment.

If necessary, the user should consult the dealer or an experienced radio and television technician for additional suggestions.

The user may find the following booklet prepared by the Federal Communications Commission helpful: "How to Identify and Resolve Radio-TV Interference Problems". This booklet is available from the U.S. Government Printing Office, Washington, DC 20402, Stock No. 004-000-00345-4.

1.4 European Community (CE) Specific Information

The European Community (CE) has established certain specific standards regarding equipment of this type. Whenever a difference exists between CE and non-CE standards, the information or instructions concerned are identified by means of shadowed boxes similar to the one below.

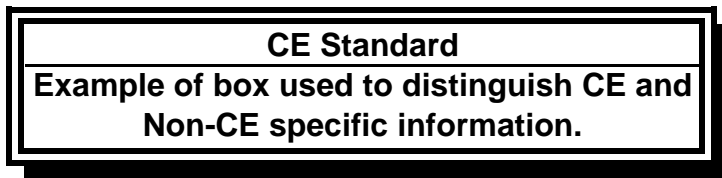

1.5 Shipping Damage Claim Procedure

What to do if your equipment arrives damaged:

Please note that this equipment was carefully inspected and packed by skilled personnel before leaving the factory. The freight company assumes full responsibility for safe delivery upon acceptance of the equipment.

1. File Claim for Damages Immediately—Regardless of extent of damage.
2. Visible Loss or Damage—Be sure this is noted on the freight bill or express receipt and is signed by the person making the delivery.
3. Concealed Loss or Damage—If damage is unnoticed until equipment is unpacked, notify Freight Company or carrier immediately and file a concealed damage claim. This should be done within 15 days of date of delivery. Be sure to retain container for inspection.

1.6 Service Information

McDonald's store personnel perform routine maintenance. For non-routine maintenance or repairs, or for service information, contact your local Frymaster Authorized Service Center (FASC). Service information may also be obtained by calling the Frymaster Technical Services Department (1-800-24FRYER). The following information will be needed in order to assist you efficiently:

Model Number _____

Serial Number _____

Voltage _____

Nature of the Problem _____

RETAIN AND STORE THIS MANUAL IN A SAFE PLACE FOR FUTURE USE.

CHAPTER 2: INSTALLATION INSTRUCTIONS

2.1 General

Proper installation is essential for the safe, efficient, trouble-free operation of this appliance. Any unauthorized alteration of this equipment will void the Frymaster warranty.

 **DANGER**

Copper wire suitable for at least 167° F (75° C) MUST be used for power connections.

 **DANGER**

The electrical power supply for this appliance MUST be the same as indicated on the rating and serial number plate located on the inside of the fryer door.

 **DANGER**

This appliance MUST be connected to the voltage and phase as specified on the rating and serial number plate located on the inside of the fryer door.

 **DANGER**

All wiring connections for this appliance MUST be made in accordance with the wiring diagrams furnished with the equipment. Wiring diagrams are located on the inside of the fryer door.

 **DANGER**

Do not store or use gasoline or other flammable vapors and liquids in the vicinity of this or any other appliance.

In the event of a power failure, the fryer(s) will automatically shut down. If this occurs, turn the power switch OFF. Do not attempt to start the fryer(s) until power is restored.

This appliance must be kept free and clear of combustible material, except that it may be installed on combustible floors.

A clearance of 6 inches (15cm) must be provided at both sides and back adjacent to combustible construction. A minimum of 24 inches (61cm) should be provided at the front of the equipment for servicing and proper operation.

 **WARNING**

Do not block the area around the base or under the fryers.

The duct system, the hood, and the filter bank must be cleaned on a regular basis and kept free of grease. See the appropriate Maintenance Requirement Cards.

2.2 After Fryers Are Under The Fry Station Hood

Adjust casters so that fryers are level and at the proper height in the fry station hood. If necessary, level the fryer(s) by loosening the locking screw on the caster leg and screwing the caster in or out. When fryer is level and at proper height, retighten the locking screw on the caster leg.

Secure the fryer in place under the hood with the restraining hardware installed with the hood.

2.3 Power Requirements

⚠ DANGER

Copper wire suitable for at least 167°F (75°C) MUST be used for power connections.

| MODEL | VOLTAGE | PHASE | WIRE SERVICE | MIN. SIZE | AWG (mm ²) | AMPS PER LEG | | |
|------------------|---------|-------|--------------|-----------|------------------------|--------------|----|----|
| | | | | | | L1 | L2 | L3 |
| H14 | 208 | 3 | 3 | 6 | (16) | 39 | 39 | 39 |
| H14 | 240 | 3 | 3 | 6 | (16) | 34 | 34 | 34 |
| H14 | 480 | 3 | 3 | 8 | (10) | 17 | 17 | 17 |
| H14 | 220/380 | 3 | 4 | 6 | (16) | 21 | 21 | 21 |
| H14 | 240/415 | 3 | 4 | 6 | (16) | 20 | 20 | 21 |
| H14 | 230/400 | 3 | 4 | 6 | (16) | 21 | 21 | 21 |
| ALL 14 SERIES | 208 | 3 | 3 | 6 | (16) | 39 | 39 | 39 |
| | 240 | 3 | 3 | 6 | (16) | 34 | 34 | 34 |
| EPRI UNITS | 220/380 | 3 | 4 | 6 | (16) | 21 | 21 | 21 |
| | 240/415 | 3 | 4 | 6 | (16) | 20 | 20 | 20 |

⚠ DANGER

The electrical power supply for this appliance MUST be the same as indicated on the rating and serial number plate located on the inside of the fryer door.

⚠ DANGER

This appliance MUST be connected to the voltage and phase as specified on the rating and serial-number plate located on the inside of the fryer door.

⚠ DANGER

All wiring connections for this appliance MUST be made in accordance with the wiring diagrams furnished with the equipment. Wiring diagrams are located on the inside of the fryer door.

2.4 Frypot Boil-Out

Before the fryer is first used for cooking product, it should be boiled out to ensure that any residue from the manufacturing process has been completely eliminated.

Also, after the fryer has been in use for a period of time, a hard film of caramelized vegetable oil will form on the inside of the frypot. This film should be periodically removed by following the boil-out procedure.

Refer to Fryers Maintenance Requirement Card (MRC) 14A for the boil-out procedure.

CHAPTER 3: OPERATING FRYERS WITH M100B™ COOKING COMPUTERS

3.1 Equipment Setup and Shutdown Procedures

Setup

WARNING

Fill the frypot to the bottom oil level line with vegetable oil before pressing the ON/OFF switch  to the ON position. Failure to do so could damage the frypot.

0. Fill the frypot with vegetable oil to the bottom OIL LEVEL line located on the rear of the frypot. This will allow for oil expansion as heat is applied. Do not fill cold oil any higher than the bottom line; overflow may occur as heat expands the oil.
0. Ensure that the power cord(s) is/are plugged into the appropriate receptacle(s). Verify that the face of the plug is flush with the outlet plate, with no portion of the prongs visible.
0. Ensure that the vegetable oil level is at the *top* OIL LEVEL line when the vegetable oil *is at its programmed cooking temperature*. It may be necessary to add vegetable oil to bring the level up to the proper mark, *after the oil has reached the programmed cooking temperature*.

CAUTION

Do not add vegetable oil to the fryer between the time the computer is turned on and the time it reaches programmed cooking temperature. Doing so is likely to cause **RECOVERY LOCKOUT (REC LOC)**. See Section 3.4.

Shutdown

0. Press the ON/OFF switch  to the OFF position (the display will show OFF).
2. Filter vegetable oil and clean fryers.
3. Place the frypot covers on frypots.

3.2 Introduction To The M-100B™ Cooking Computer

The M-100B cooking computer, illustrated on the following page, automatically maintains fryer temperature to cook products according to preprogrammed cooking specifications. The computer also acts as a cooking process timer, displaying the remaining cooking time for each product and alerting the operator by sound and display message to shake or pull the product at the correct time. It also signals quality control (hold-time) limits. The computer automatically adjusts cooking times to compensate for variances in product temperature and basket load so that, for example, a full basket of cold fries will be cooked to the same quality as half a basket of fries at room temperature.

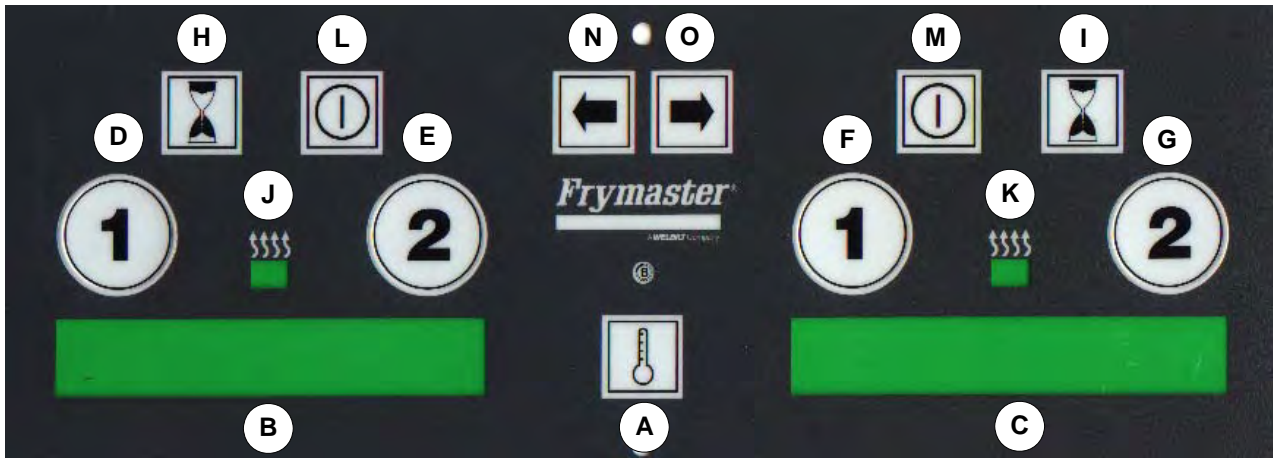

| ITEM | DESCRIPTION |
|------|--|
| A | Temperature Display Switch |
| B | Left LED Display |
| C | Right LED Display |
| D | Cook Switch #1, Left |
| E | Cook Switch #2, Left |
| F | Cook Switch #1, Right |
| G | Cook Switch #2, Right |
| H | Recovery/Use Time Recall Switch, Left |
| I | Recovery/Use Time Recall Switch, Right |
| J | Light - Left Heating Mode Indicator |
| K | Light - Right Heating Mode Indicator |
| L | Switch - Left ON/OFF |
| M | Switch - Right ON/OFF |
| N | Switch - Left Product Selection |
| O | Switch - Right Product Selection |

To quickly determine the software version number and the current configuration of an M-100B computer, with the computer turned OFF (**OFF** in both displays) press the temperature check  switch. The displays will automatically cycle through the version number, power configuration (gas or electric), EPRA configuration (On or Off), and frypot configuration (full- or split-).

The M-100B is factory-programmed with McDonald's cooking specifications for a group of seven standard products. The cooking times and temperature settings for these factory-programmed products can be changed by store personnel if required. Additionally, two *test menus* are available for store personnel to program product names, cooking times, temperature settings, and shake or duty times for products not included on the factory-programmed menu. The test menus can also be set to automatically adjust the cooking rate to compensate for product variances.

For units equipped with built-in filtration, the computer times the polishing process and alerts the operator when the polishing time has elapsed. (**Polishing** refers to circulating the vegetable oil through the filtration system for a specified time.)







The fryer has two built-in high-limit protection features. If the temperature in the frypot reaches approximately 410°F (210°C), the computer opens the heat relay circuit, turning the elements off. If the temperature in the frypot reaches 450°F (232°C), a mechanical high-limit shuts off electrical power to the elements. The operator should periodically test each of the high-limit protection features to verify that they are operating correctly. Refer to Grills/Fryers Maintenance Requirement Card (MRC) 15 for the procedure.

3.3 M-100B™ Computer Operating Instructions

 **WARNING**

Before pressing the on/off switch  to the ON position, ensure that the frypot is properly filled with vegetable oil. See Section 3.1.







Operating the Computer on Full-Vat Fryers

0. Turn ON the cooking computer by pressing the right ON/OFF switch . A product name (for example, **FR FRIES**) will appear in the right LED display.
0. If the frypot temperature is below 180°F (82°C), the computer will automatically enter a warm-up cycle (often called a melt cycle). The heating elements will cycle on and off repeatedly, allowing the vegetable oil to heat gradually, without scorching. During the warm-up cycle, the right heating mode indicator  will alternately illuminate and go out as the elements cycle on and off. Within about 45 minutes, the computer will exit the warm-up cycle and the heat mode indicator  will remain continuously illuminated.
0. The M-100B computer allows the operator to use both sides of the computer if desired. By having both sides of the computer on, the operator can select two products that have the same cooking temperature, but different cooking times. Using a pair of twin baskets, both products can be cooked at the same time.
0. To activate the left side of the computer, press the left ON/OFF switch . A product name will be displayed in the left LED display.
0. Select the product to be cooked by pressing the right product selection switch  (or, if both sides of the computer are ON, the left product selection switch ) until the desired product is displayed.

Once the frypot temperature is above 180°F (82°C), but still 15°F (8°C) or more below the setpoint temperature for the product displayed (for example, french fries), the computer will alternately display **LOW TEMP** and **FR FRIES**, and the right heating mode indicator  will remain continuously illuminated.

The cooking cycle cannot be started until the cooking oil is within ±15°F (8°C) of the programmed setpoint. When the frypot temperature is within ±15°F (8°C) of the programmed setpoint, the product name will be displayed continuously, indicating that the fryer is ready to cook the displayed product.

Operating the Computer on Split-Vat Fryers

1. Turn ON the cooking computer by pressing the ON/OFF switches . Pressing the left switch turns on the left side of the computer; pressing the right switch turns on the right side. A product name (for example, **FR FRIES**) will appear in the LED display corresponding to the switch pressed.
2. If the frypot temperature is below 180°F (82°C), the computer will automatically enter a warm-up cycle (often called a melt cycle). The heating elements will cycle on and off repeatedly, allowing the vegetable oil to heat gradually, without scorching. During the warm-up cycle, the heating mode indicator  will alternately illuminate and go out as the elements cycle on and off. Within 45 minutes, the computer will exit the warm-up cycle and the heat mode indicator  will remain continuously illuminated.
3. Select the product to be cooked by pressing the left or right product selection switches  , depending upon the vat in which you wish to cook.
4. Once the frypot temperature is above 180°F (82°C), but still 15°F (8°C) or more below the setpoint temperature for the product displayed (for example, french fries), the computer will alternately display **LOW TEMP** and **FR FRIES**, and the heating mode indicator  will remain continuously illuminated.
5. The cooking cycle cannot be started until the cooking oil is within ±15°F (8°C) of the programmed setpoint. When the frypot temperature is within ±15°F (8°C) of the programmed setpoint, the product name will be displayed continuously, indicating that the fryer is ready to cook the displayed product.

Viewing the Frypot Temperature (Actual or Setpoint)

To display the actual frypot temperature, press the temperature check switch  once. To display the setpoint temperature, press the switch twice.

Cooking Product (Full-Vat or Split-Vat)

1. Fill basket(s) with product, lower the basket into the vegetable oil, then press the cook switch (① or ②) that corresponds to the full- or split-vat to be used. This will activate the cooking cycle of the product.

Example 1: In a full-vat fryer, press cook switch ① when the first basket of twin baskets of fries is dropped. Halfway through the first cooking cycle, drop the second basket and press cook switch ②.

Example 2: The M-100B is programmed to cook Crispy Chicken (**CSPY**) and Chicken McNuggets (**NUG**) in the same side of a split-vat arrangement. Cook switch ① corresponds to Crispy Chicken, and cook switch ② corresponds to Chicken McNuggets.
2. The display will show the number of minutes and seconds of cooking time remaining.

3. At the programmed shake time, an audible alarm will sound and the display will flash **SHAKE**. After shaking the basket, press the corresponding cook switch, ① or ②, to cancel the alarm.
0. After the completing the cooking time, an audible alarm will sound and the display will flash **pu l l**. Remove the indicated basket and press the corresponding cook switch, ① or ②, to cancel the alarm. If no other products are being cooked in the frypot, the display shows **7:00 QA** indicating that the quality timer is counting down. If the quality time is set for some time other than 7:00 minutes, the display starts counting down from that time. (QA is not available for McChicken, Crispy Chicken or Filet-o-Fish).
0. When the quality time expires, an audible alarm will sound, and the display will flash **QA**. Cancel the alarm by pressing the corresponding cook switch, ① or ②.

NOTE: When you initiate a new cook cycle, the quality time will automatically reset.

3.4 M-100B™ Computer Problem Condition Indicators

Open Drain Valve Indication

If, when the ON/OFF  switch is pressed to the ON position, the display reads **IGNITION FAILURE**, verify that the drain valve is fully closed. A drain safety switch built into the drain valve assembly prevents the elements from being energized if the valve is not completely closed. After verifying that the valve is fully closed, turn the computer OFF* for at least 5 seconds, then turn it back on. If the message reappears, there is a problem in the electrical circuitry of the fryer or the computer; contact your Frymaster Factory Authorized Service Center (FASC).

* On early-version M-100B split-vat units, BOTH computers must be turned off, even though the problem condition may be associated with only one vat.

Low Temperature Indication

If the frypot temperature drops to more than 45°F (25°C) below the programmed setpoint temperature during the cooking cycle, the cook switches will lock, the display will flash **LOW TEMP** and an audible alarm will sound. If the frypot temperature returns to a range between 45°F (25°C) to 15°F (8°C) of setpoint, the audible alarm will stop, but the cook switches remain locked and the display alarm continues flashing. All functions return when the frypot temperature is within 15°F (8°C) of the programmed setpoint.

Probe Failure Indication

If the temperature probe fails, the display will flash **PROBE FAILURE** and an audible alarm will sound. To cancel the alarm, turn the computer OFF. In split-vat fryers, turn off the side in which the failure occurred. If a probe fails during the high-limit test, **PROBE FAILURE** is displayed.

NOTE: If the temperature probe fails in the left side of a split-vat, that side cannot be turned back ON once it has been turned OFF.

Recovery Out of Range (REC LOC)

Recovery time is an indication of the condition of the fryer. When the fryer is first turned on, the computer records the amount of time it takes to heat the cooking oil from 250°F (121°C) to 300°F (149°C). Also, anytime the temperature of the oil drops below 180°F (82°C), such as when cold oil is added, the computer will check the recovery time. If the fryer takes longer than 1 minute and 40 seconds to recover, the display will show **REC LOC** and the computer will lock out.

To clear the **REC LOC** condition, enter the program mode (see *How to Enter the Program Mode* in on page 3-10) and push the temperature check switch  (see **diagram below**).

It is easy to view the currently recorded recovery time with the computer ON. Press the recovery recall switch  for the frypot you wish to check. On full-vat units, press the right switch.

If **REC LOC** occurs three or more times within a week, verify that oil is not being added while the fryer is heating (that is, while a heat mode indicator  is illuminated) and that the fryer's power cord is fully plugged in. If oil is not being added while the fryer is heating, and the power cord is fully plugged in, have the fryer checked by a qualified service agent.

Clearing REC-LOCK

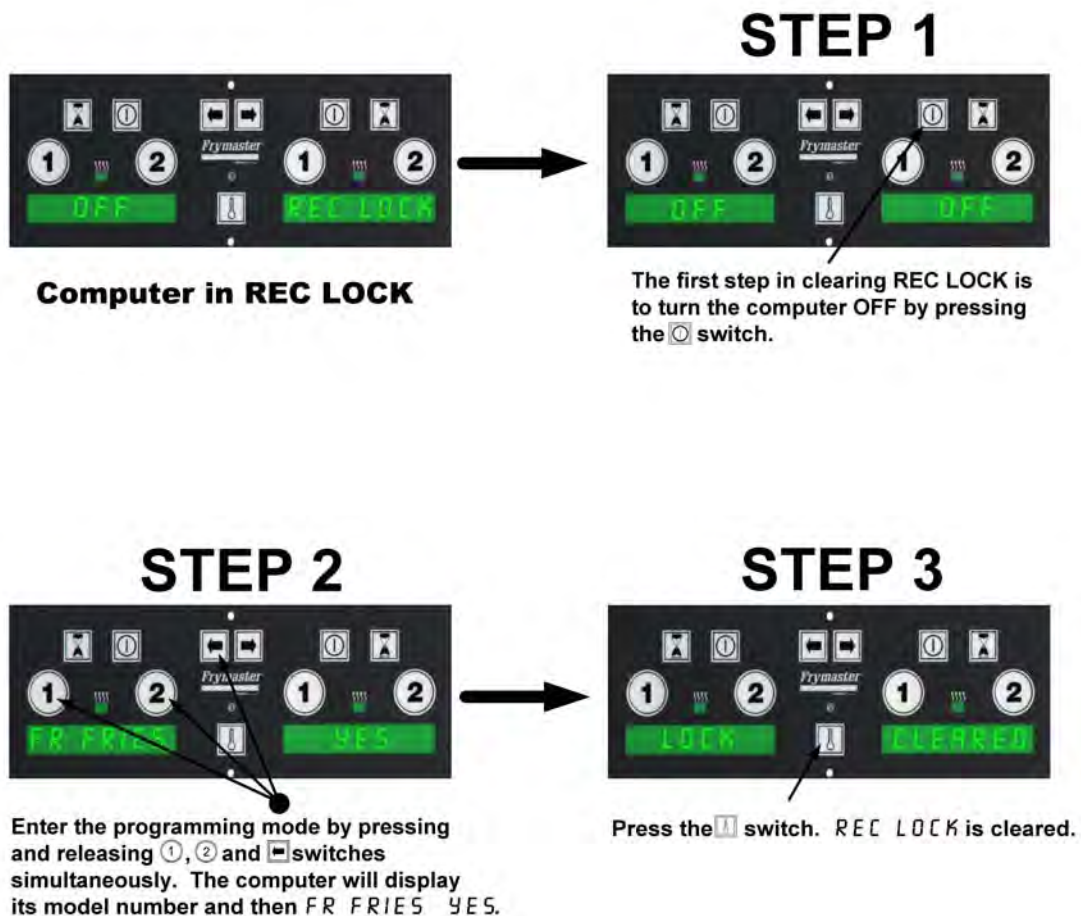

3.5 M-100B™ Computer Set-Up and Programming Instructions

The M-100B computer has three modes of operation. In addition to the *Cooking Mode*, which was discussed in Sections 3.3 and 3.4, there is a *Setup Mode* and a *Programming Mode*. (The cooking mode is the computer's default mode – when the computer is turned on, it comes up in the cooking mode.)

In the Setup Mode, the operator can:

- change the computer's display language
- configure the computer for use on electric or gas fryers
- configure the computer for use on either a full-vat or a split-vat fryer
- specify how the computer displays product names and temperatures
- calibrate computer temperature to actual frypot temperature
- activate or deactivate the frypot BOIL OUT feature

In the Program Mode, the operator can:

- reset the computer to the factory default settings
- change the shake, pull, and QA (hold) times for menu items
- change the cooking temperature setpoints for menu items
- add products and cooking parameters to the two test menus
- suppress a duty function in a menu item
- turn the display of a menu item in the factory-programmed menu on or off
- display usage information that is automatically recorded by the computer

3.5.1 M-100B™ Computer Setup Mode

How to Enter the Setup Mode

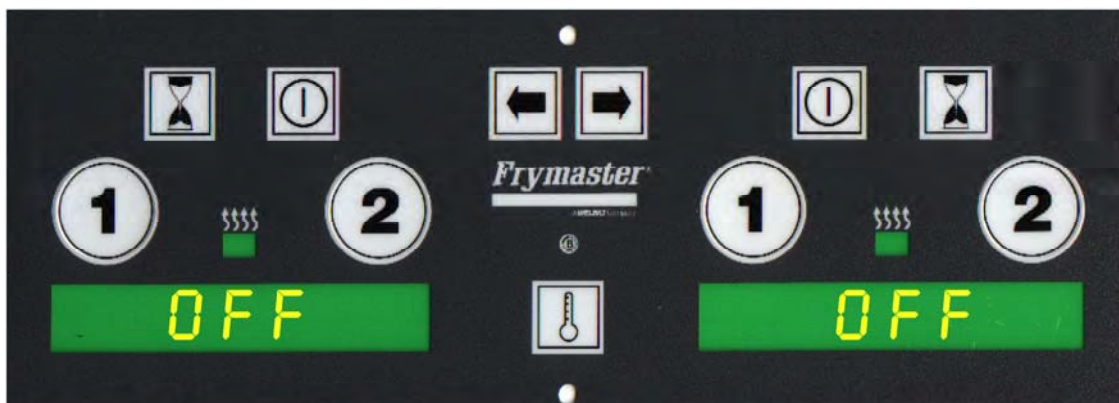

1. Turn both sides of the computer OFF by pressing the  switches. OFF will appear in both LED displays.





2. Press the right ,  and  switches simultaneously.

3. Release all 3 switches at the same time. **M100B**, then **SETUP** will appear briefly in the left display, then **BOIL-OUT** will appear in the left display and **YES** or **NO** will appear in the right display.



How to Change the Computer's Display Language

1. Enter the setup mode. See *How to Enter the Setup Mode* on page 3-7.
2. Press and release the  switch until the word **l a n g u a g e** appears in the left LED display.
3. Press the right ① or ② switch until the desired language (English, French, French-Canadian, Spanish, or Portuguese) is displayed in the right LED display.
4. When the desired language is displayed, press either ON/OFF switch  to lock in the selection. The right display will show **l o a d i n g** for about 5 seconds, indicating that the computer's display language is being changed, then both displays will change to **OFF**.

How to Configure the Computer for Use on an Electric Fryer





1. Enter the setup mode. See *How to Enter the Setup Mode* on page 3-7.
2. Press and release the  switch until **GAS Yes** or **GAS no** appears in the LED displays.
3. **Gas nO** indicates the computer is configured for use on an electric fryer; **Gas YES** indicates the computer is configured for use on a gas fryer. Press the right ① or ② switch to change the configuration.
4. Press the  switch to save the settings.
5. Press either ON/OFF switch  to save the setting and exit the setup mode. Both displays will change to **OFF**.

How to Configure the Computer for Use on Either a Full-Vat or a Split-Vat Fryer

1. Enter the setup mode. See *How to Enter the Setup Mode* on page 3-7.
2. Press and release the  switch until **1 vat** appears in the left display.
3. Press the right ① or ② switch to toggle back and forth between full-vat (**yes**) or split-vat (**NO**).
4. Press the  switch to save the settings.
5. Press either ON/OFF switch  to exit the setup mode. Both displays will change to **OFF**.







How to Change Computer Product/Temperature Displays



1. Enter the setup mode. See *How to Enter the Setup Mode* on page 3-7.

2. Press and release the  switch until the word **DISPLAY** appears in the left display.
3. Press the right  or  switch to toggle back and forth between constant product display (**CONSTANT**) or alternating temperature and product display (**ALT**).
4. Press the  switch to save the settings.
5. Press either ON/OFF switch  to exit the setup mode. Both displays will change to **OFF**.





How to Calibrate Computer Temperature to Actual Frypot Temperature

NOTE: For this procedure, *actual frypot temperature* refers to the temperature of the oil in the frypot as measured with a good-grade thermometer or pyrometer. The computer's temperature can only be adjusted $\pm 5^{\circ}\text{F}$ ($\pm 3^{\circ}\text{C}$). The computer cannot be adjusted to a temperature greater than 375°F (191°C).

1. Enter the setup mode. See *How to Enter the Setup Mode* on page 3-7.
 1. Press and release the  switch until **CALIB** appears in the display.
 1. Press the temperature check switch . The frypot temperature sensed by the computer will be displayed. In split-vat units, the temperatures for each side will be displayed.
 1. **For the left side of a split-vat:** Press the left  switch to go UP a degree (maximum of 5 for Fahrenheit or 3 for Celsius). Press the left  switch to go DOWN a degree (maximum of 5 for Fahrenheit or 3 for Celsius).
- For the right side of a split-vat or for a full-vat:** Press the right  switch to go UP a degree (maximum of 5 for Fahrenheit or 3 for Celsius). Press the right  switch to go DOWN a degree (maximum of 5 for Fahrenheit or 3 for Celsius).



1. Press the  switch to save the settings.
1. Press either ON/OFF switch  to exit the setup mode. Both displays will change to **OFF**.

How to Activate or Deactivate the Frypot BOIL-OUT Feature

0. Enter the setup mode. See *How to Enter the Setup Mode* at the beginning of this section.
0. Press and release the  switch until **BOIL-OUT** appears in the display.
0. Press the right  or  switch to toggle the boil-out mode ON or OFF.
0. Press the  switch to save the settings.
0. Press either ON/OFF switch  to exit the setup mode. Both displays will change to **OFF**.

3.5.2 M-100B™ Computer Programming Mode



How to Enter the Program Mode

1. Press the ON/OFF  switches until both displays of cooking computer indicate OFF. Press the *left* product selection switch  and the *left* ① and ② cook switches simultaneously. Release all three switches at the same time.
2. When the program mode has been entered, the display will flash M-100B computer briefly, followed by the software version number. After a few seconds, Fr fries yes or Fr fries no will be displayed, depending upon previous program settings.

How to Reset the Computer to the Factory Defaults

While in the program mode, press all 4 cook switches (left and right ① and ②) simultaneously to reset the computer to the factory defaults. See *How to Enter the Program Mode* above. Updating menu will flash in the display, followed by epra cleared and cooks cleared. After a few seconds, Fr fries yes will be displayed, indicating that the computer has been reset to the factory defaults.

How to Change the Shake, Pull, Or Quality Times for Menu Items

1. Enter the program mode. (See *How to Enter the Program Mode* above.)
2. Press and release the  switch until the product to be changed appears in the left display.
3. Press and release the  switch until the function to be changed (SHAKE, PULL, or QA) appears in the left display. The current time setting and automatic (AUTO) or manual (MAN) alarm cancel mode options appear in the right display.

NOTE: *Shake Time* refers to the programmed time at which the operator will be prompted by an audible alarm to shake the basket, but not stop the cooking process. *Pull Time* refers to the programmed time at which the product is fully cooked and at which the operator will be prompted by an audible alarm to remove the basket from the cooking oil. *QA Time* refers to the maximum time that a product may be held after the cooking cycle has completed.

NOTE: When the programmed time has elapsed, the automatic alarm-cancel mode (AUTO) audible alarm will sound three times and then stop. When the programmed time has elapsed, the manual alarm cancel mode (MAN) audible alarm will sound until the operator presses the cook switch (① or ②) that was pressed to start the cooking cycle.



4. Press the right ② switch to toggle between automatic alarm cancel mode (AUTO) and manual alarm cancel mode (MAN).

- To change the times, use the following switches:

| | | |
|-------|---|--------------------------------|
| Left |  | Minutes (in increments of ten) |
| Left | ① | Minutes (in increments of one) |
| Left | ② | Seconds (in increments of ten) |
| Right | ① | Seconds (in increments of one) |

- Press the  switch to lock in the new settings, and either ON/OFF switch  to exit the programming mode. Both displays will show **OFF**.

How to Change the Cooking Temperature Setpoint





- Enter the program mode. See *How to Enter the Program Mode* on page 3-10.
- Press and release the  switch until the menu item to be changed is displayed.
- Press the  switch to show the cooking temperature setpoint, displayed as **SET-TEMP** in the left display. The current setpoint temperature is in the right display (for example-**350F**). The temperature will be in Fahrenheit (**F**) or Celsius (**C**). Pressing the right  switch toggles the computer between Fahrenheit (**F**) and Celsius (**C**).
- To change the temperature, use the following switches:

| | | |
|-------|---|----------|
| Left | ① | Hundreds |
| Left | ② | Tens |
| Right | ① | Ones |

NOTE: The computer cannot be programmed for a temperature greater than 375°F (191°C).



- Exit the program mode by pressing either ON/OFF switch .





How to Enter a Product Name in a Test Menu

- Enter the program mode. See *How to Enter the Program Mode* on page 3-10.
- Press the  switch to select Test Menu 1 or 2.
- Press the  switch to enter the edit mode. The right display will show **EDIT** and a blinking cursor will appear in the left display.
- To enter a letter, use the left  switch to go UP in the alphabet. Use the left  switch to go DOWN in the alphabet.

NOTE: Characters available are the letters A-Z and the numbers 0-9. Special characters *, , -, ?, and / are also available, as is a blank space.



NOTE: Pressing the left  switch will reset the product name to the factory defaults.





- To move to a different character position, use the  or  switches.

6. To EXIT and SAVE the product name entry, press the  switch. **SAVE** will flash in the right display, followed by **YES** or **NO**, indicating whether the menu item is active or not. Press the right  or  switch to toggle between yes and no.
7. Press the  switch to cycle through the Duty Times, Pull Time, QA (hold) Time, and Cooking Temperature Setpoint settings. Program the times and the set point in accordance with the section that follows.



How to Program Duty Times, Pull Time, QA Time, and Setpoint for a Test Menu Item

NOTE: *Duty Time* refers to an operator-specified time within a cooking cycle when the computer will sound an alarm to prompt a particular duty such as shaking the basket.

1. Enter the program mode. See *How to Enter the Program Mode* on page 3-10.
2. Press the  switch to select the desired test menu.
3. Press the  switch. **DUTY1** will appear in the left display. The currently programmed time appears in the right display. To program the time, use the following switches:

| | | |
|-------|---|--------------------------------|
| Left |  | Minutes (in increments of ten) |
| Left |  | Minutes (in increments of one) |
| Left |  | Seconds (in increments of ten) |
| Right |  | Seconds (in increments of one) |



Press the right  switch to toggle between the manual alarm cancel mode (**MAN**) and the automatic alarm cancel mode (**AUTO**).



NOTE: In the automatic alarm cancel mode (**AUTO**), when the programmed time has elapsed, an audible alarm will sound three times and then stop. In the manual alarm cancel mode (**MAN**), when the programmed time has elapsed, an audible alarm will sound until the operator presses the cook switch ( or ) that was pressed to start the cooking cycle.



4. Press the  switch, **DUTY2** appears in the left display. The currently programmed time appears in the right display. Program the time in the same manner as Duty1 time.

NOTE: Enter a time of **00:00** to bypass this option.





NOTE: In the steps that follow, *Pull Time* refers to the programmed time at which the product is fully cooked and an audible alarm will prompt removal of the basket from the cooking oil. *QA Time* refers to the maximum time that a product may be held after the cooking cycle has completed.

5. Press the  switch to display **PULL** in the left window. Program the pull time in the same manner as the duty times.
6. Press the  switch to display **QA** in the left window. Program the QA time in the same manner as the duty times.







- Press the  switch to show the cooking temperature setpoint, displayed as **SET-TEMP** in the left display. The current setpoint temperature is in the right display (for example-**350F**). The temperature will be in Fahrenheit (**F**) or Celsius (**C**). Pressing the right  switch toggles the computer between Fahrenheit (**F**) and Celsius (**C**). To change the temperature, use the following switches:

| | | |
|-------|---|----------|
| Left |  | Hundreds |
| Left |  | Tens |
| Right |  | Ones |





NOTE: The computer cannot be programmed for a temperature greater than 375°F (191°C).

- Press the  switch to show the status of the Test Menu Cook Time Compensation feature. The display will show **PROBE** in the left window and **YES** or **NO** in the right window. With the feature set to **YES**, the cooking time of the product will be temperature-compensated; with the feature set to **NO**, the product cooking time will not be compensated. Press the right  or  switch to toggle between **YES** or **NO**.
- Exit the program mode by pressing the right  switch. Both displays will show **OFF**.

How to Suppress a Shake, QA, or Duty Function



- Enter the program mode. See *How to Enter the Program Mode* on page 3-10.
- Press and release the  switch until menu item to be modified is displayed in the left window.
- Press and release the  switch until the function to be suppressed is displayed in the left window.
- Use the cook switches , ,  from left to right to set the time display to read **000**. This will suppress the function during the cooking cycle. To reactivate the function, follow steps 1 through 3 to enter a time for the function.
- Exit the program mode by pressing the right  switch.

How to Turn the Display of a Factory-Programmed Menu Item On and Off

- Enter the program mode. See *How to Enter the Program Mode* on page 3-10.
- Press and release the  switch until the menu item to be turned on or off is displayed in the left window.
- The right display will show **YES** or **NO**. To turn the menu item **OFF**, press either of the right  or  switches to set the option to **NO**. To turn the menu item **ON**, change the option to **YES**.
- Exit the Program Mode by pressing the right  switch. Both displays will read **OFF**.

How to Display “Use Time” Information





NOTE: This feature is used to determine the total amount of time that a fryer has been cooking.

1. Enter the program mode. See *How to Enter the Program Mode* on page 3-10.
2. Press the left  switch to display use time for the left side of a dual-vat unit. Press the right  switch to display use time for a full-vat unit or the right side of a dual-vat unit.
3. To reset use time data to zero, while pressing one of the  switches, press the same side's ① and ② switches, then release them simultaneously.

NOTE: The simultaneous release of these three switches is critical. If not done correctly, data will not reset.



How to Display the Product Cycle Accumulator Information

NOTE: This feature keeps a running total of cooking cycles per product.

1. Enter the program mode. See *How to Enter the Program Mode* on page 3-10.
2. Press the left or right  switch.
3. For the left vat, press the  switch. For the right or for a full-vat, press the  switch. A running total of cooking cycles per product will be displayed.
4. To clear the accumulated times from computer memory, press either  switch, then the  switch.

How to Use the Filter Countdown Timer

NOTE: This feature starts a five-minute countdown timer to time the polishing of vegetable oil during the filtering process. **Polishing** refers to circulating the vegetable oil through the filtration system for a specified time. This feature does not have any direct control over the filtration process; it is only a timer.

1. With the computer ON, press and release the  switch until **FILTER** appears in the display. (For split-vat units, press and release the  switch for the left vat.)
2. Press either of the right ① or ② switches. The computer will begin to countdown from five minutes to zero. (For split-vat units, press either of the left ① or ② switches for the left vat.)

CHAPTER 4: OPERATING FRYERS WITH ANALOG CONTROLLERS

4.1 Equipment Setup and Shutdown Procedures

Setup

 **WARNING**

Fill the frypot to the bottom oil level line with vegetable oil before pressing the power switch to the ON position. Failure to do so could damage the frypot.

Fill the frypot with vegetable oil to the bottom OIL LEVEL line located on the rear of the frypot. This will allow for oil expansion as heat is applied. Do not fill cold oil any higher than the bottom line; overflow may occur as heat expands the oil.

Ensure that the power cord(s) is/are plugged into the appropriate receptacle(s). Verify that the face of the plug is flush with the outlet plate, with no portion of the prongs visible.

Set the thermostat knob to the desired frying temperature.

Ensure that the vegetable oil level is at the *top* OIL LEVEL line when it *is at its intended cooking temperature*. It may be necessary to add vegetable oil to bring it up to the proper level.

Shutdown

1. Press the POWER switch to the OFF position (the POWER light will go out).
2. Filter vegetable oil and clean fryers.
3. Place the frypot covers on the frypots.

4.2 Introduction to the Analog Controller

The analog controller, illustrated on the following page, is used to adjust and maintain vegetable oil at the temperature indicated by the thermostat knob. The fryer has two built-in high-limit protection features. If the temperature in the frypot reaches approximately 410° F (210° C), the computer opens the heat relay circuit, turning the elements off. If the temperature in the frypot reaches 450° F (232° C), a mechanical high-limit shuts off electrical power to the elements. The operator should periodically test each of the high-limit protection features to verify that they are operating correctly. Refer to page 4-3, Analog Controller High-Limit Check, or the Grills/Fryers Maintenance Requirement Card (MRC) 15 for the procedure.

The analog controller has no timing features. Shake, pull, and QA (hold) times must be monitored by the operator.

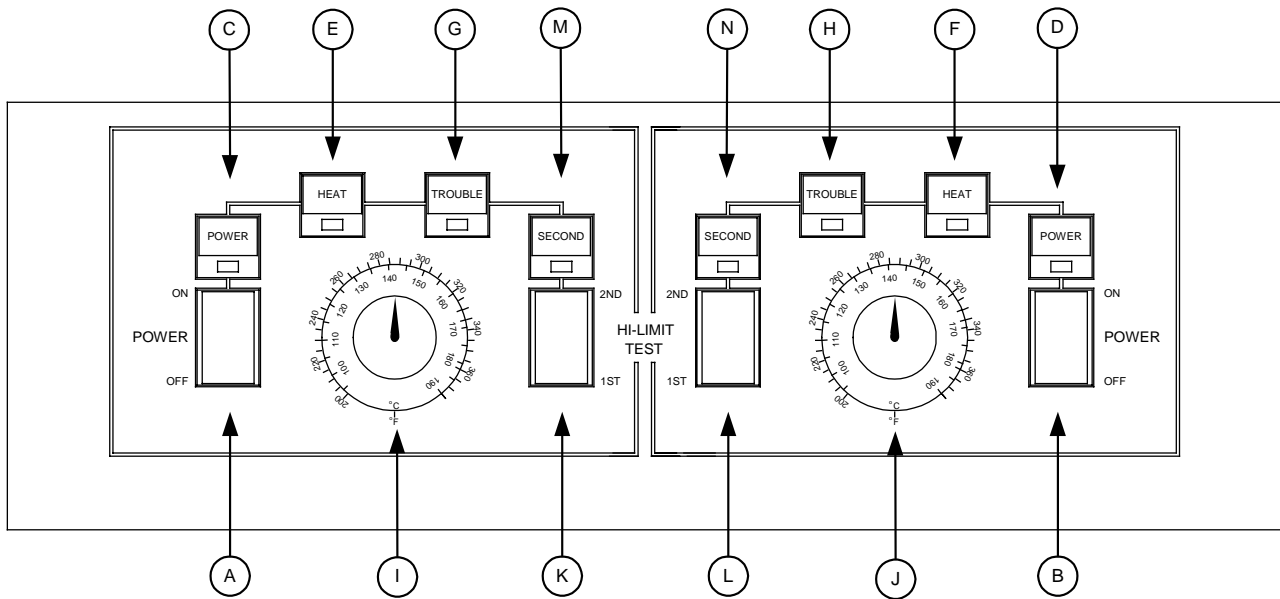

**SPLIT VAT CONTROLLER ILLUSTRATED
FULL VAT CONTROLLER HAS ONLY LEFT SET OF CONTROLS**

| ITEM | DESCRIPTION |
|------|---|
| A | Power Switch, Left or Full-Vat - Controls electrical power to fryer. |
| B | Power Switch, Right Vat - Controls electrical power to fryer. |
| C | Power-On Light, Left or Full-Vat - Indicates when electrical power to fryer is ON. |
| D | Power-On Light, Right Vat - Indicates when electrical power to fryer is ON. |
| E | Heating Mode Light, Left or Full-Vat - Indicates when heating element is ON. |
| F | Heating Mode Light, Right Vat - Indicates when heating element is ON. |
| G | Trouble Light, Left or Full-Vat - Indicates over high-limit or problem in heat control circuitry. |
| H | Trouble Light, Right Vat - Indicates over high-limit or problem in heat control circuitry. |
| I | Thermostat Control Knob, Left or Full-Vat - Sets desired frying temperature. |
| J | Thermostat Control Knob, Right Vat - Sets desired frying temperature. |
| K | Hi-Limit Test Switch, Left or Full-Vat - Tests high-limit thermostat for left vat (or full-vat). |
| L | Hi-Limit Test Switch, Right Vat - Tests high-limit thermostat for right vat. |
| M | Second Hi-Limit Test Light, Left or Full-Vat - Indicates fryer is in second high-limit test mode. |
| N | Second Hi-Limit Test Light, Right Vat - Indicates fryer is in second high-limit test mode. |

4.3 Analog Controller Operating Instructions

 **WARNING**

Before pressing the power switch to the ON position, ensure that the frypot is properly filled with vegetable oil. See Section 4.1.

1. Verify that the thermostat knob is set to the desired cooking temperature. For split-vat units, set both knobs.
2. Press the power switch to the ON position. The POWER light will illuminate. For split-vat units, both power switches must be placed in the ON position if both vats are to be used.
3. If the frypot temperature is below 180° F (82° C), the controller will automatically enter a warm-up cycle (often called a melt cycle). The heating elements will cycle on and off repeatedly, allowing the vegetable oil to heat gradually, without scorching. During the warm-up cycle, the heating mode light will alternately illuminate and go off as the elements cycle on and off. Within about 45 minutes, the controller will exit the warm-up cycle and the heating mode light will remain continuously illuminated.
4. When the vegetable oil temperature reaches the thermostat knob setpoint, the elements will cycle OFF and the heating mode light will go off, indicating that the fryer is ready for the cooking process to begin.

4.4 Analog Controller High-Limit Check

Tools needed: Maple Paddle

Note: Conduct this test when fryer will not be needed for about one hour, and when the vegetable oil is due to be changed. Discard the vegetable oil after completing this check

Note: Check high-limit on only one vat at a time.

 **CAUTION**

Grease filters must be in place and exhaust fans MUST be ON during entire high-limit control-check procedure.

1. The vegetable oil should be at the normal/shortening level line. Add vegetable oil if necessary.
2. Remove the computer probe from the probe holder and replace it with fry vat probe.
3. Turn the vat power switch to “ON” and set thermostat knob to its highest setting, and wait for heating light to go OFF.

Note: You must agitate vegetable oil during the entire high-limit control-check procedure with a maple paddle.

 **CAUTION**

If after completing both high-limit tests you find only the second high-limit operates properly, the vat can be used if it is absolutely necessary, but with extreme care. The controller must be replaced immediately after this period of necessity. If the second high-limit does not work the vat must not be used until the second high-limit has been replaced. If the first high-limit feature activates at less than 400°F (204°C), do not replace the controller unless it interferes with proper cooking. If the second high-limit activates at less than 425°F (218°C), do not replace it unless it prevents you from checking the first high-limit feature.

4. Press and hold "first high-limit" position of the vat high-limit test switch.

Result: Electrical element or gas burner turns OFF and "TROUBLE" light comes ON. Vegetable oil temperature should be between 400° and 425°F (204° and 218°C).

5. Press and hold "second high-limit" position of the vat high-limit test switch.

Note: When the trouble light comes ON, or the temperature exceeds 425°F (218°C), release switch.

Result: Electrical elements or gas burner turns OFF and the second high-limit will come ON. The vegetable oil temperature should be between 425° and 450°F (218° and 232°C).

 **CAUTION**

When the second high-limit light comes on, or the temperature exceeds 450°F (232°C), release switch.

6. Turn the power switch to the "OFF" position. One vat must remain ON to ensure hood fan remains ON.

7. Remove the fry vat probe and reinstall the computer probe into the vat.

8. Allow vegetable oil to cool for one hour before discarding. See statement on discarding oil (Chapter 5).

Note: Hot oil must not be transported until it cools to 100°F (38°C) or less.

High-Limit check is complete. Repeat procedure for each remaining vat.

CHAPTER 5: OPERATING THE BUILT-IN FILTRATION SYSTEM

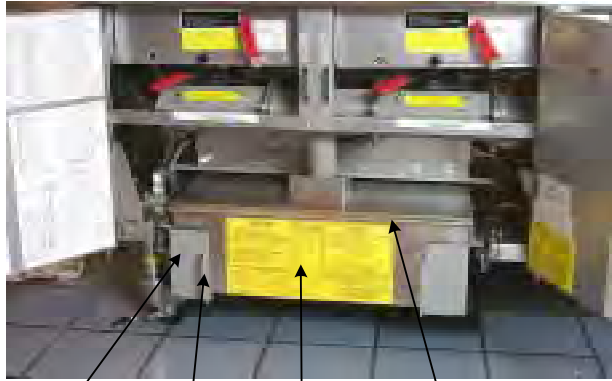

- ①
- ⑤
- ②
- ④

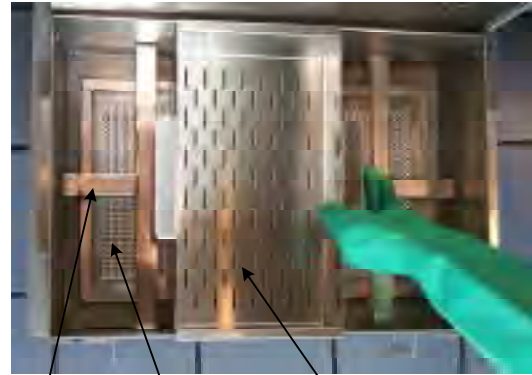

- ③
- ⑥
- ⑦

| ITEM | DESCRIPTION | FUNCTION |
|-------------------|-----------------------------|---|
| 1 | Filter Base Assembly | Housing for filter pan. |
| 2 | Filter Pan Assembly | Collects vegetable oil during filtering process. |
| 3 | Filter Paper Hold-down Ring | Secures filter paper or pad in place. |
| * | O-ring, Filter Pan | Seals pan suction line. |
| 4 | Pan Cover | Covers filter pan assembly. |
| * | Screw, Pan Cover Hinge | Attaches pan cover to filter pan. |
| 5 | Filter Base Handle | Means to pull filter assembly from fryer. |
| 6 | Filter Paper Screen | Fits under filter paper/pad to allow passage of oil when filtering. |
| 7 | Crumb Screen | Collects heavy breading when draining oil into filter pan. |
| * Not Illustrated | | |

8.1 STEP-BY-STEP FILTRATION INSTRUCTIONS



Switch computer to OFF.



Slide the filter pan from the fryer cabinet.



Open the filter-cover, and remove and clean the crumb tray.

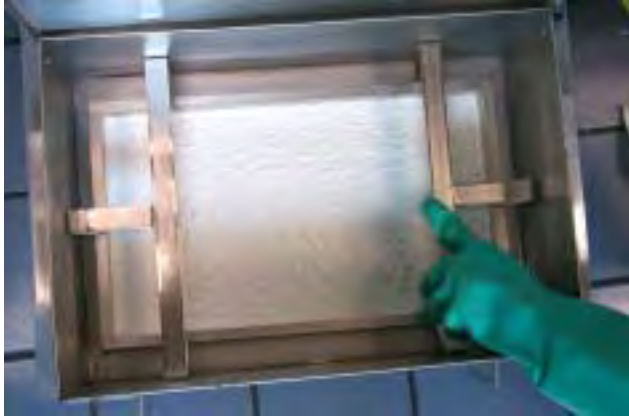

Remove and clean the hold-down ring.
Remove and discard the dirty paper or pad.



Remove and clean the filter screen.



Make sure the inside of the pan is free of all food and breading particles that could prevent the screen from sealing against the bottom of the pan.



Install the filter screen in the bottom of the pan. Proper operation of the filter system depends upon proper placement of the filter screen. Never filter with the screen alone.



The filter pad is placed in the pan with the heavily textured side facing up. When filter paper is used, one sheet is placed over the screen and 8-ounces of filter powder is spread evenly on the top of the paper.



WARNING: Do Not Use Filter Powder on Filter Pads



Place pad evenly on filter screen. If paper is used, position the paper on top of the pan with the edges evenly overlapping. **Ensure that the screen is in place prior to pad or paper placement.**



Install hold-down ring over pad, or use ring to push filter paper to the bottom of the pan. Push down firmly to properly seat the paper/pad.



Use 8-ounces of filter powder and spread it evenly over filter paper. **Remember, Do Not Use filter powder on filter pads.**



Replace crumb screen inside the filter pan. It's imperative that the crumb screen is installed prior to filtering, for optimum filter-system performance.



Slide the filter pan back inside fryer cabinet.



Important: Filter shortening or oil at operating temperature. Filtering at the end of the day ensures that the shortening or oil is at proper temperature.



Drain-Valve Handle

Return Handle

Return handle and drain-valve handle location.





With fryer off, open drain valve.



When frypot empties into filter pan, turn return handle to ON. Filter pump will activate.



Turn the computer back ON and use right arrow key  to step through selection, stopping on FILTER. Press right  button to initiate five-minute timer for filtering.



The computer will countdown the process, although it does not control the filtering.



The oil moves through the filter, the frypot and out the open frypot-drain during filtering.



Polishing is a timed process that cleans the oil and washes small particles from the frypot.



When the final seconds of the process tick off, FILTER will flash in the display, indicating the filter time has elapsed.





Close the drain-valve and leave the filter pump on to fill the frypot.



With the drain-valve closed, frypot fills with oil.



When the filter pan empties, bubbles will form in the frypot. Allow bubbling to continue 15-20 seconds to ensure the oil return lines are clear of shortening.



Turn off filter pump.



Turn the filter alarm off by pressing .



Top up oil level. Some oil may be lost in filtering process.



Fill to first mark in frypot.



The oil may drop below operating temperature during the filtering process. In that case, the fryer will display Low-Temp and heat the oil when it is turned on.

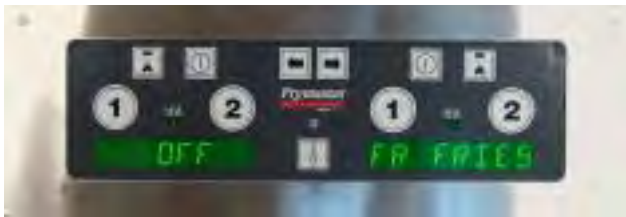

Return fryer to operation, or filter another frypot in the battery. Remember, only one frypot can be filtered at a time.

8.2 CARE AND CLEANING OF YOUR FRYER AND FILTER SYSTEM

CAUTION: Never operate the fryer or filter system without vegetable oil in the system.

1. Filter vegetable oil as often as needed. If a heavy volume of breaded food is fried, filter as often as every hour. Filtering often increases the life of the vegetable oil and produces a better-tasting product. The best rule to follow is to *"filter before you think it is needed"*. Even with a product such as french fries, you should filter two to three times per day for best results.
2. Periodically clean the frypot. Cleaning the frypot, combined with disposing of old vegetable oil enhances the flavor of the food product. After the fryer is empty, drain the frypot and close the drain valve. Fill the frypot to the OIL LEVEL line (or the bottom line for fryers equipped with two oil-level lines) with water and the correct amount of **McD All Purpose Concentrate (APC) Cleaner HSC**. Place the baskets into the frypot and bring the solution to a simmer at 195° F (90.5° C) for 1 hour. Turn OFF the fryer, drain the solution and wipe the frypot clean and dry.

NOTE: Do not drain water into the filter pan. Water will damage the filter pump enough to require replacement. Use a stockpot or bucket.

3. The filter pan and filter base assembly must be cleaned on initial start-up and periodically thereafter.
 - a. To clean the filter pan, lift pan from the filter base. Take the filter pan to a sink filled with warm water and grease-cutting detergent.
 - b. Scrub the filter pan with the frypot brush shipped with the fryer.
 - c. Rinse the filter pan thoroughly to remove the detergent. Wipe dry with a clean, dry cloth or paper towels.

- d. To clean the filter base assembly, use a sponge or cloth soaked with a water and grease-cutting solution. Be careful not to get water on the pump/motor assembly.
- e. Wipe filter-base assembly dry with a clean, dry cloth or paper-towel.

 **CAUTION**

All water MUST be removed from the suction tube before inserting filter pan.

- f. Wipe the inside and outside of the tube with clean, dry cloths or paper towels.
- g. Insert filter pan into the filter base assembly.

NOTE: To drain old oil or boil-out solution, drain in an appropriate container. **DO NOT DRAIN WATER IN THE FILTER PAN.**

 **WARNING**

The filter pan MUST never be used to dispose of, or transport spent-cooking oil/shortening to the disposal area. Cooking oil /shortening MUST always be allowed to cool below 100°F (38°C) before transporting to the disposal area. A shortening disposal unit (MSDU) is available and highly recommended for safety.

⚠ CAUTION

Statement on discarding oil: Hot cooking-oil is dangerous and will cause severe burns. Handle with extreme caution. When discarding old cooking oil, drain from the fryer into a Vegetable Oil Disposal Unit (MSDU50) - available from your local distributor. The disposal unit should be taken to the disposal site and the old cooking oil pumped into the grease storage container for proper disposal.



MSDU50

CHAPTER 6: PREVENTIVE MAINTENANCE AND TROUBLESHOOTING

6.1 Preventive Maintenance

Preventive Maintenance (PM) procedures are contained in McDonald's Preventive Maintenance System Maintenance Requirement Cards (MRC) 12, 14, 14A, and 15. The cards are distributed with this manual, but are not an integral part of the manual. A replacement card set may be ordered using part number 819-5432. To order both the card set and the Operator's Manual, use part number 819-5569. To order both the card set and the Service Manual, use part number 819-5625.

6.2 Troubleshooting

This section provides an easy reference guide to some of the common problems that may occur during the operation of this equipment. The troubleshooting guides that follow are intended to help correct, or at least accurately diagnose, problems with this equipment. Although the chapter covers the most common problems reported, you may encounter problems that are not covered. In such instances, the Frymaster Technical Services staff will make every effort to help you identify and resolve the problem.

When troubleshooting a problem, always use a process of elimination starting with the simplest solution and working through to the most complex. Never overlook the obvious – anyone can forget to plug in a cord or fail to close a valve completely. Most importantly, always try to establish a clear idea of why a problem has occurred. Part of any corrective action involves taking steps to ensure that it doesn't happen again. If a controller malfunctions because of a poor connection, check all other connections, too. If a fuse continues to blow, find out why. Always keep in mind that failure of a small component may often be indicative of potential failure or incorrect functioning of a more important component or system.

Before calling a service agent or the Frymaster HOTLINE (1-800-24FRYER):

- **Verify that electrical cords are securely plugged in.**
- **Verify that circuit breakers are on.**
- **Verify that frypot drain valves are fully closed.**

 **DANGER**

Never attempt to move a fryer containing hot cooking oil or to transfer hot cooking oil from one container to another.

 **DANGER**

Use extreme care when testing electrical circuits. Live circuits will be exposed.

 **WARNING**

Inspection, testing, and repair of electrical equipment should be performed only by qualified service personnel. The equipment should be unplugged when servicing, except when electrical tests are required.

6.2.1 Troubleshooting Fryers Equipped with M100B Computers

Fryer Off

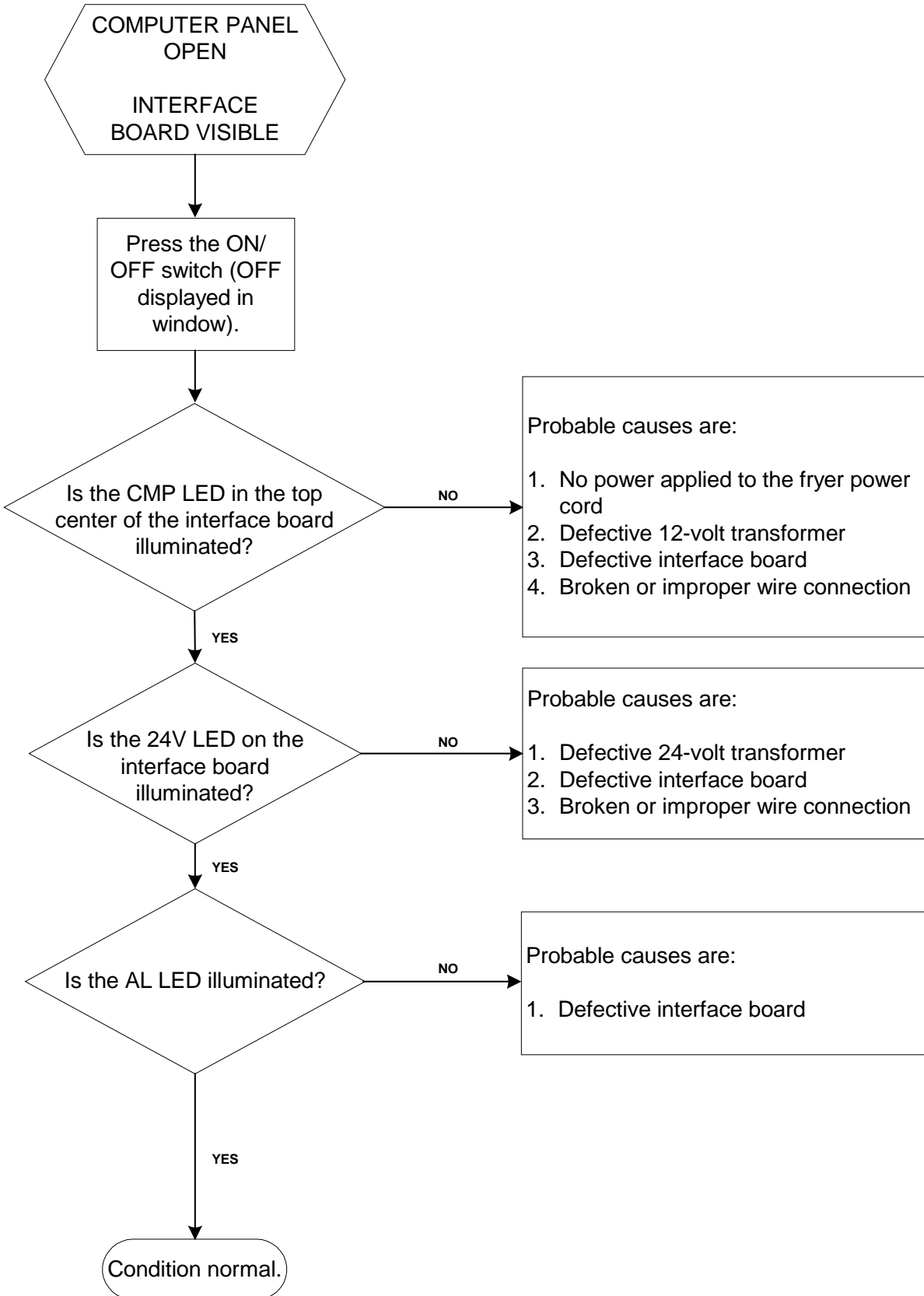

Fryer Heating Oil

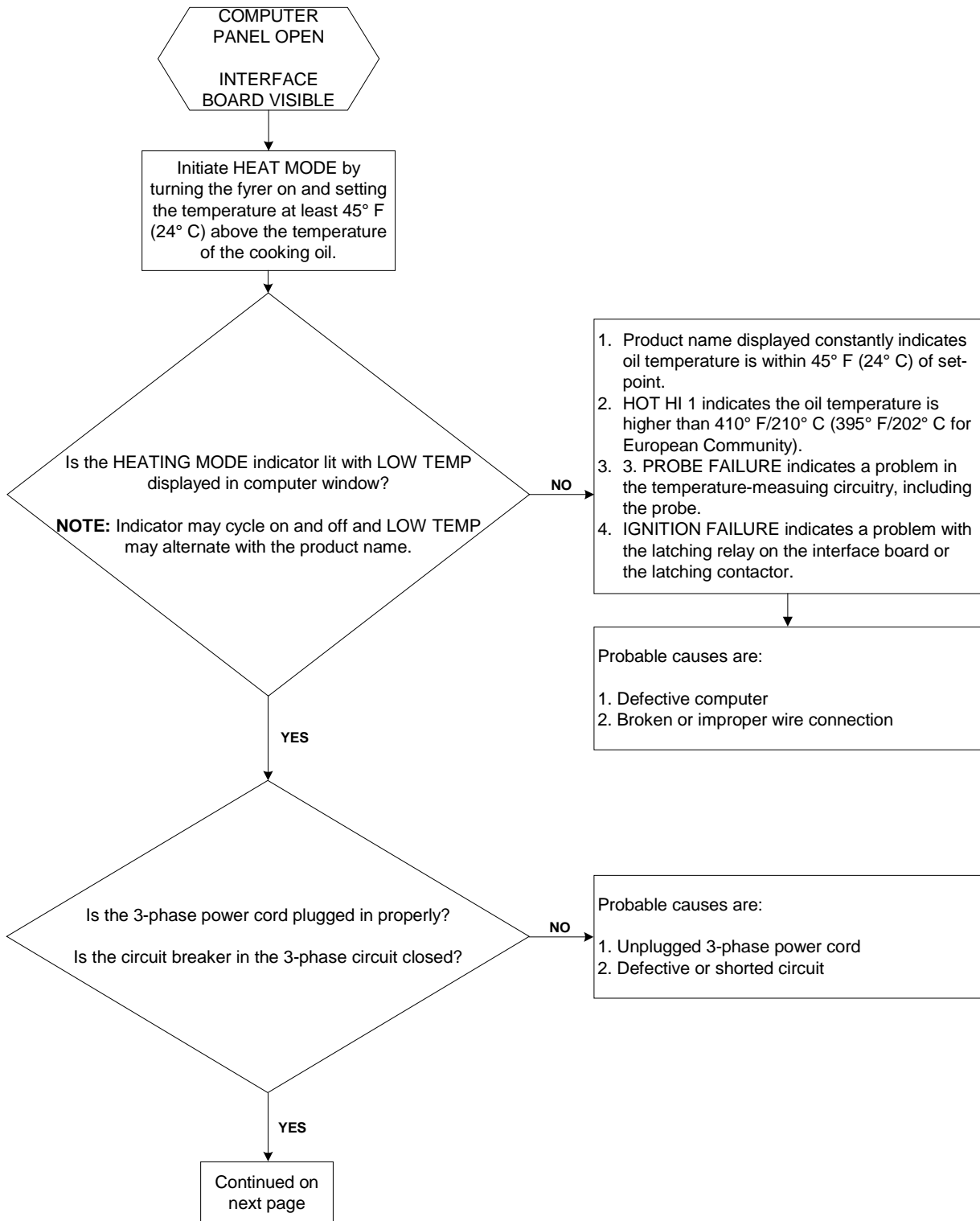

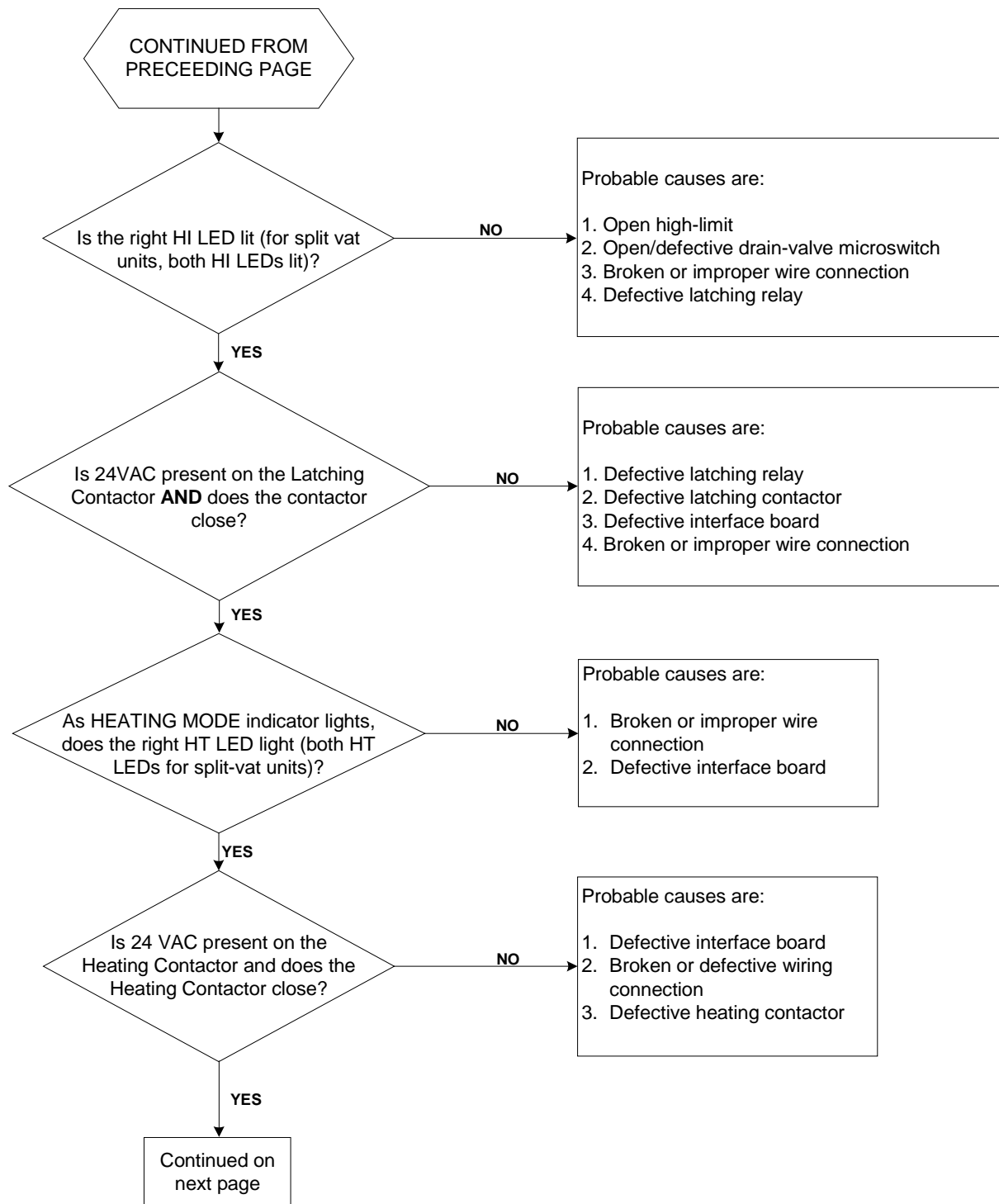

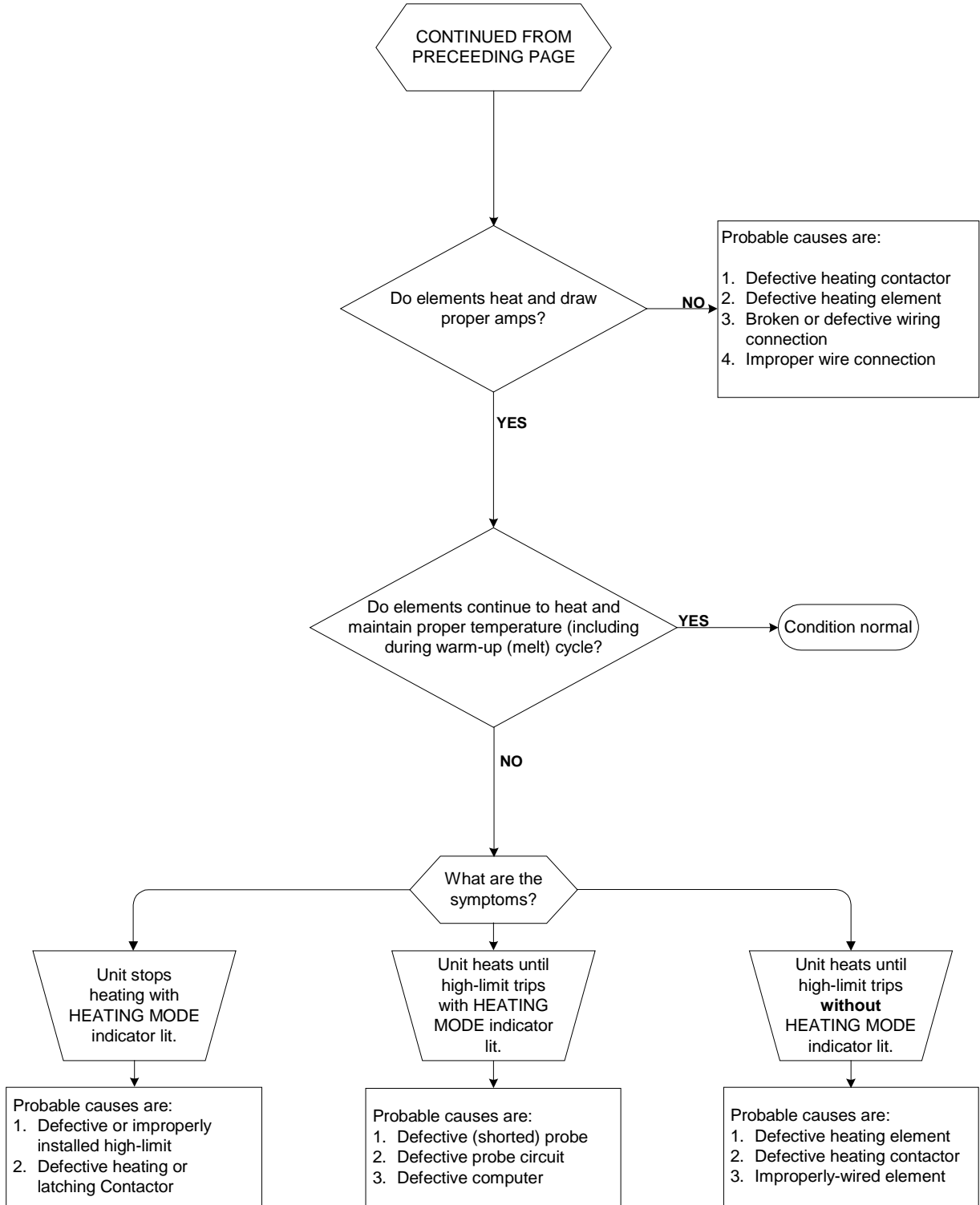

6.2.2 Troubleshooting Fryers Equipped with Analog Controllers

Fryer Off

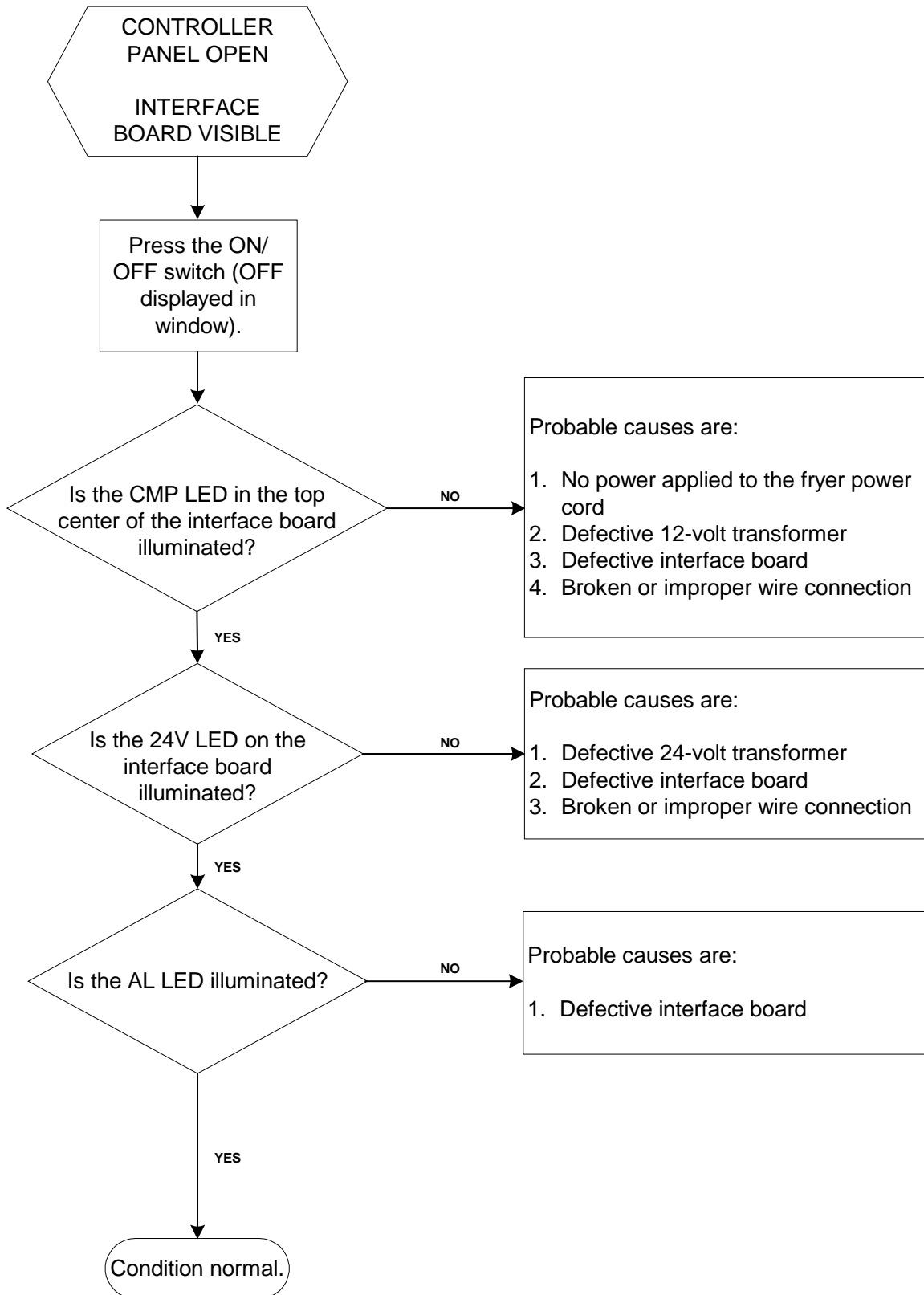

Fryer Heating Oil

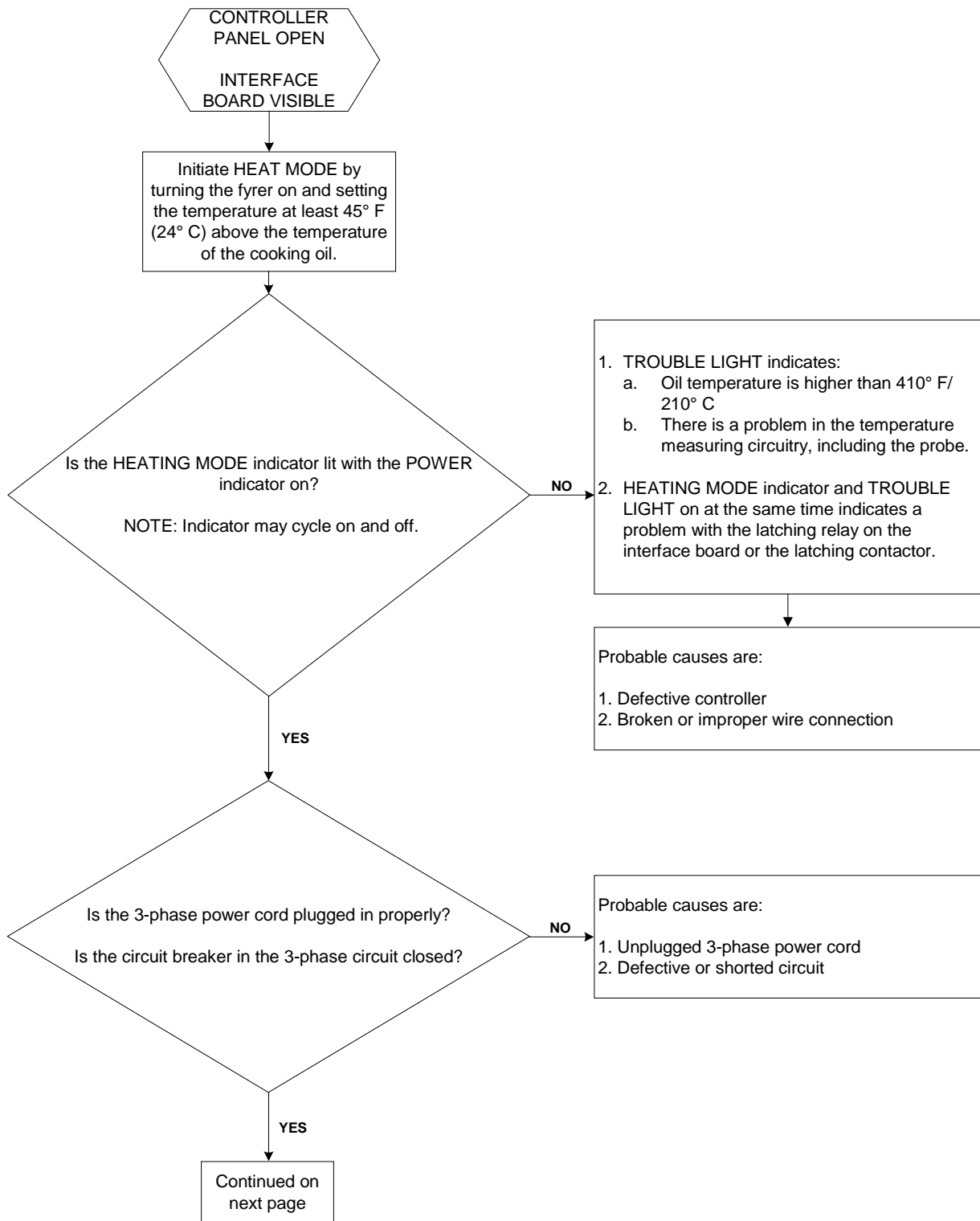

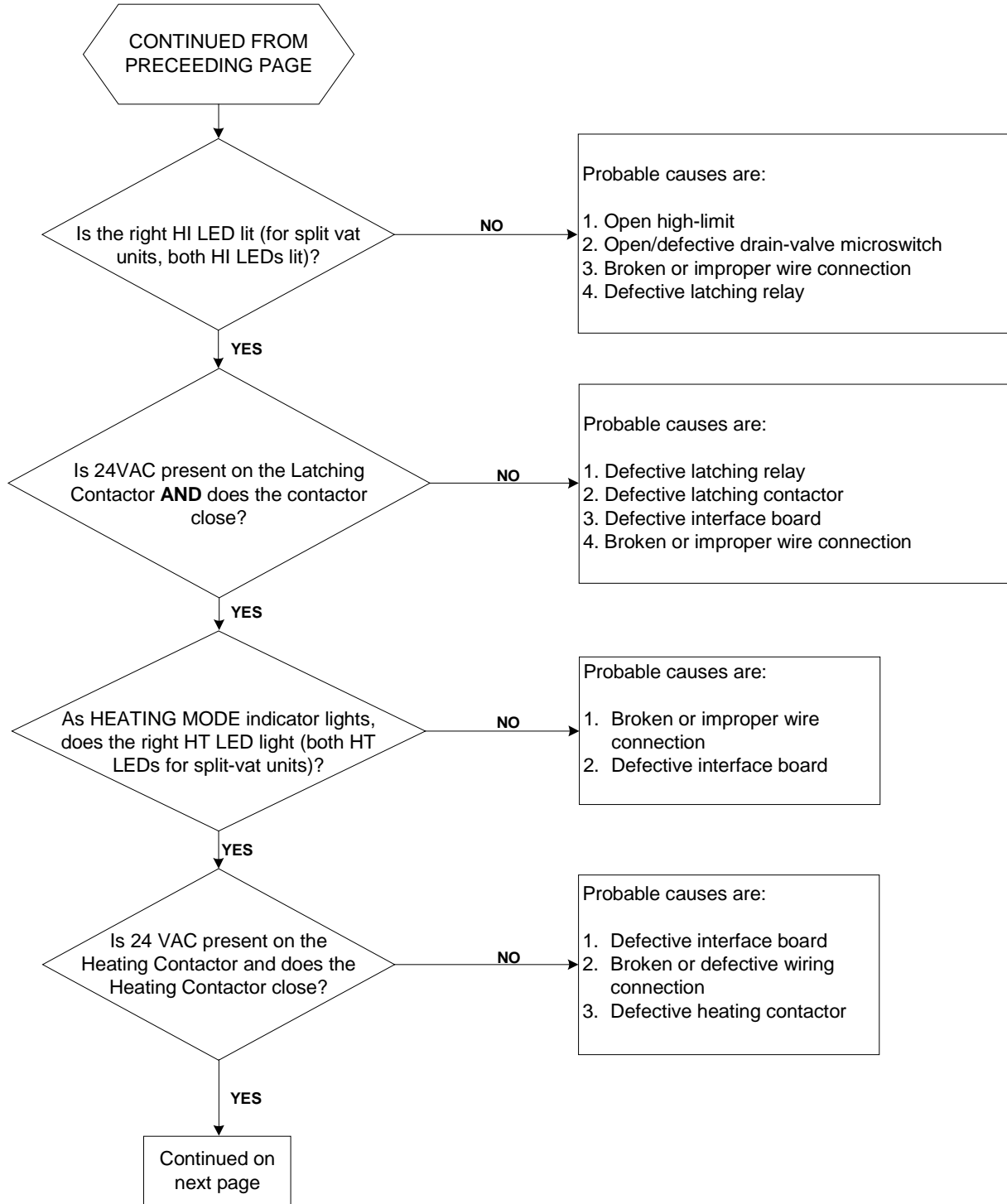

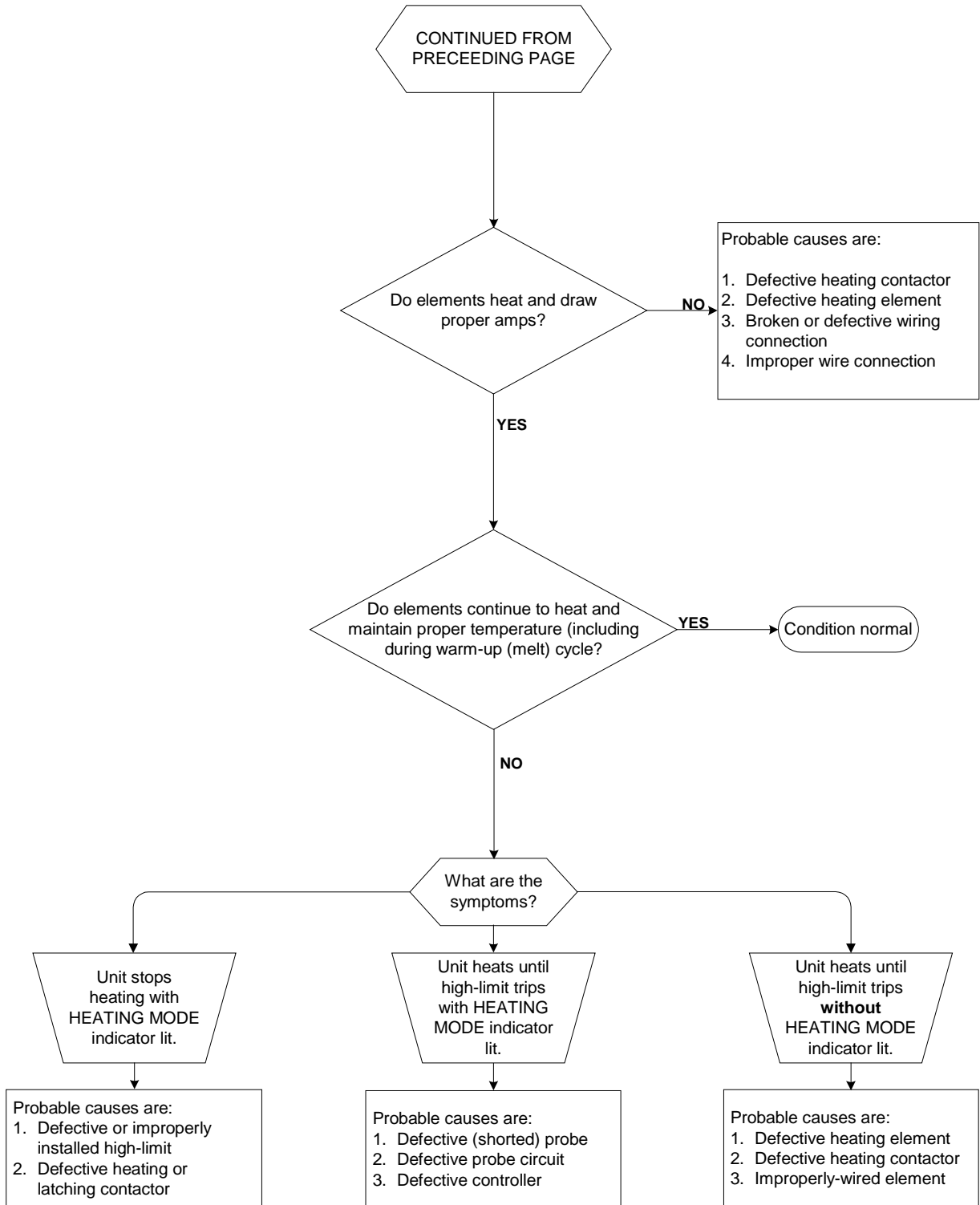

6.2.3 Troubleshooting the Built-in Filtration System (BIH14 units only)

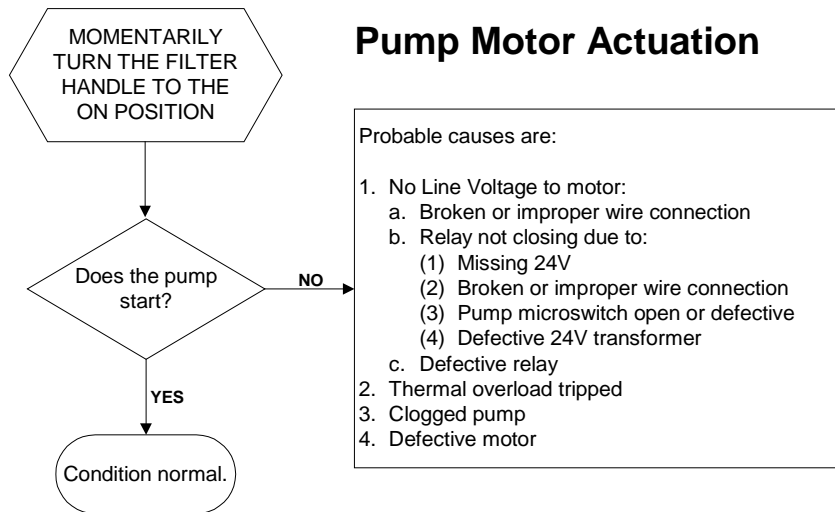

Filter System Operation

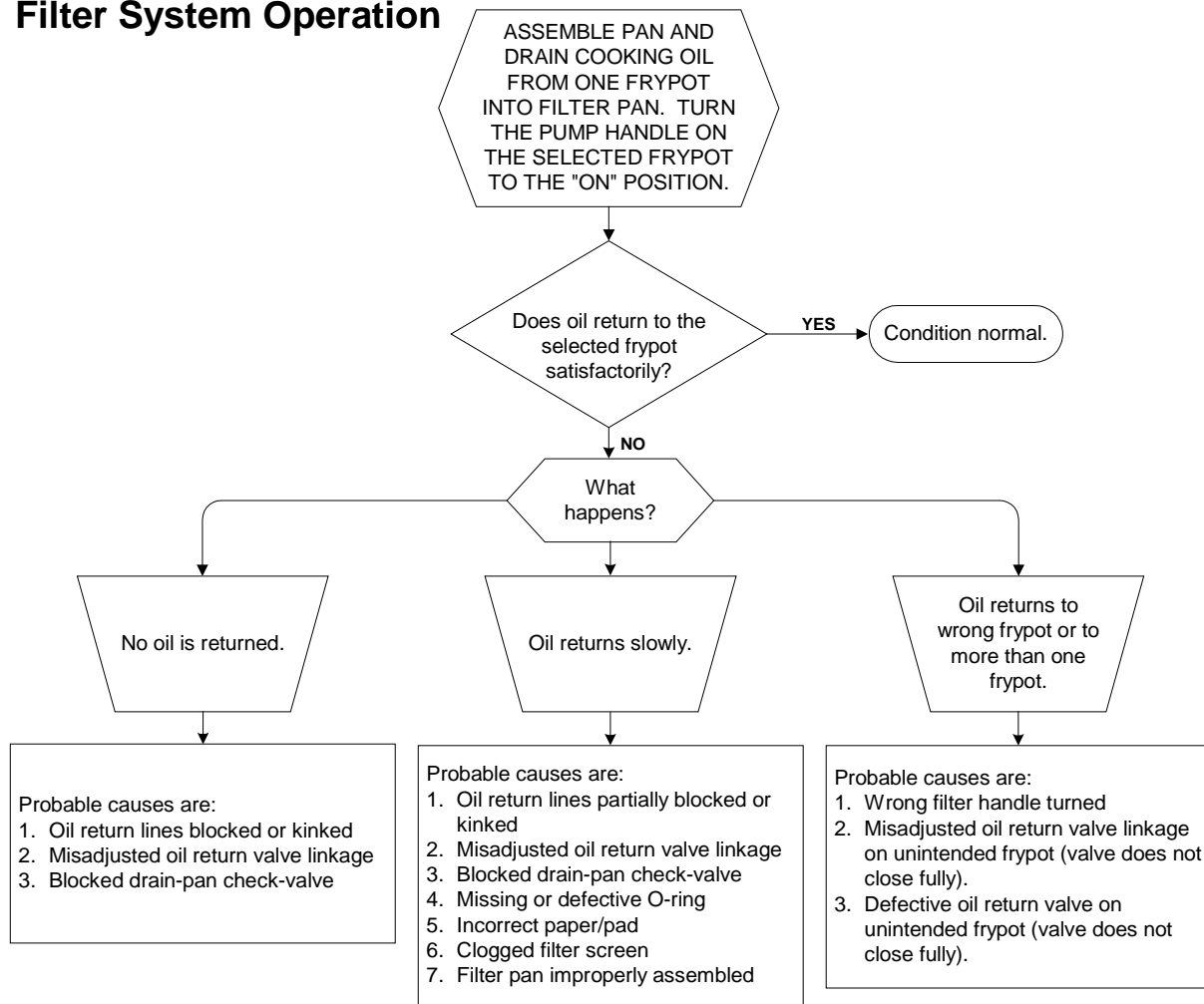

CHAPTER 7: SERVICE PROCEDURES

Before performing any maintenance on your Frymaster fryer, you must disconnect the electrical power supply.

When electrical wires are disconnected, it is recommended that they be marked in such a way to facilitate re-assembly.

7-1: REPLACE CONTROLLER

1. Unscrew and remove two control panel screws.



2. Control panel is hinged at the bottom and will swing open from the top.



3. Unplug wiring harness at plug on back of controller.
4. Control panel including controller can be removed by lifting the assembly from the hinged slots in the control panel frame.
5. Reverse procedures to install new controller.



7-2: REPLACE INTERFACE BOARD

1. Unplug all power cords. Perform Procedure 7-1, Steps 1-4, Replace Computer/Controller.

2. Unplug wire harness from the interface board. Remove all wiring from the terminals of the interface board, ensuring that each wire is marked for reattachment.



Wire Harness/Connector

3. Remove the screws securing the control panel frame. Set the control panel frame/screws aside.



Screws securing control panel frame

4. Remove the screws securing the top cap. Set the top cap/screws aside.

5. Remove the screws securing the component box. Set the component box drop down enough so that the wire harness can be unplugged from the back of the assembly.

6. Remove the nuts from each corner of the interface board and slide the board from the studs. Install the new interface board by reversing the previous procedures. Ensure that wire harnesses are connected to back of interface board prior to securing component box. Also ensure that wiring and wire harnesses are connected to the proper terminals.



Nuts securing interface board

7-3: REPLACE TRANSFORMER

1. Unplug all power cords. Perform Procedure 7-1, Steps 1-4, Replace Computer/Controller.
2. Remove all wiring from the terminals of the transformer to be replaced.
3. Remove the screws that secure the transformer to the component box.
4. Install the new transformer by reversing the preceding procedures. Make sure you reconnect the wiring to the proper terminals and the harnesses to the correct connectors.



Screws securing transformers

7-4: REPLACE TEMPERATURE PROBE

1. Unplug fryer from the electrical source.
2. Drain the cooking oil from the frypot.
3. Remove the fryer from the exhaust hood to gain access to the rear of the fryer.
4. Remove the screws from the top, center and bottom back covers. Set the covers and screws aside.
5. Remove the screws securing the tilt housing cover. Set the tilt housing cover aside.



Screws securing back covers and tilt housing

7-4: REPLACE TEMPERATURE PROBE (cont.)

6. Disconnect the wire harness containing the probe wiring. It may be necessary to remove the wire ties.
7. Use a pin-pusher to remove the probe wires from the connector. Mark each wire for re-assembly.

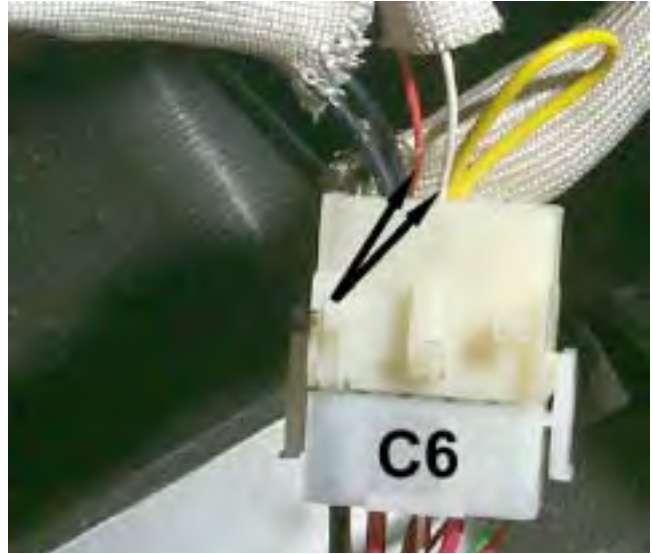

Use a pin-pusher to remove probe wires from connector

8. Remove the screw(s) securing the probe bracket to the element.



9. Thread the probe wire through the hole in the tilt plate assembly and remove the probe and the securing components from the element.
10. Remove the probe from the probe bracket. Place the new probe into the bracket.



Thread probe wire through hole in tilt plate assembly, then remove probe and components from element.

7-4: REPLACE TEMPERATURE PROBE (cont.)

11. Place the new temperature probe assembly onto the element and secure with the screws removed earlier. Clip the probe onto the rear of the element. The temperature probe assembly should be oriented in the same manner as the probe being replaced.
12. Thread the probe wires into the harness connector as removed in Step 7.
13. Lower the element into the frypot.



Secure probe to element with metal Ty-Wrap

New probe assembly properly installed in tilt plate

14. Place the tilt housing cover over the tilt housing assembly and secure with screws
15. Install the top, center and bottom back covers and secure with screws.



Tilt housing cover in place

7-5: REPLACE HEATING ELEMENT

1. Perform Procedure 7-4, Replace Temperature Probe, Steps 1-7.
2. Remove the element wires from the connector. Press down on either side of the connector while pulling up on the top portion. The connector will open from the top. Pull all wires from the connector.

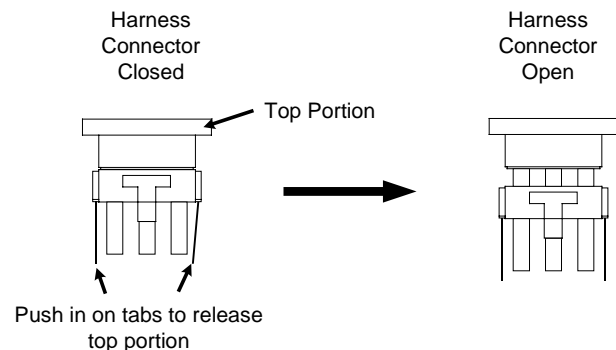

7-5: REPLACE HEATING ELEMENT (cont.)

3. Remove the screws securing the temperature probe bracket from the element. Remove the probe clamp (metal Ty-Wrap). Set the temperature probe and probe-securing components aside.

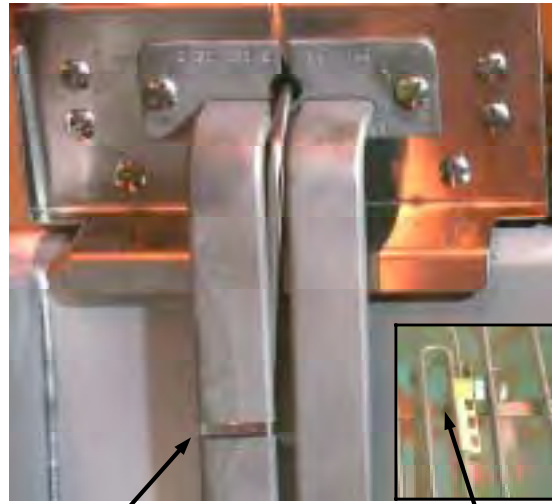

Remove probe clamp (metal Ty-Wrap), and screws securing probe bracket to element

4. Disconnect the element springs.



Disconnect element springs here

7-5: REPLACE HEATING ELEMENT (cont.)

5. Remove the element mounting screws and pull the element out of the frypot.
6. Install the temperature probe and probe-securing components onto the replacement element.
7. Install the replacement element in the frypot and secure with the mounting screws removed in Step 5.

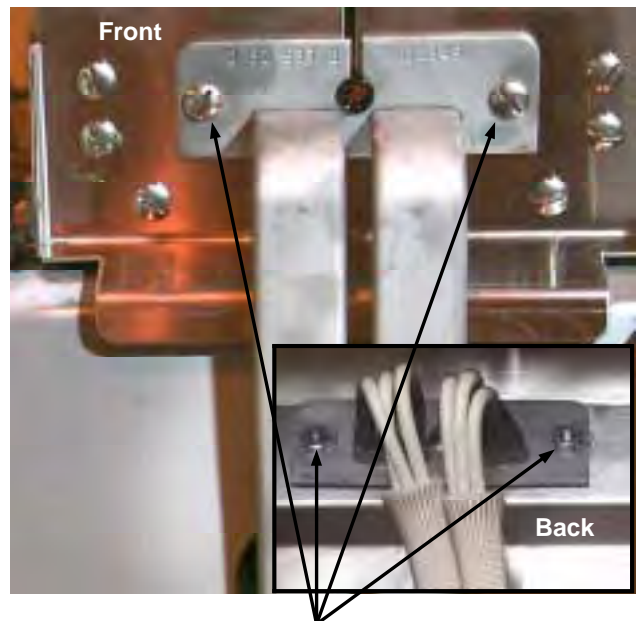

Element-mounting screws and nuts
(Inset Photo- back of tilt plate)

8. Route the element leads (terminals) to the rear of the fryer.
9. When replacing the right element (as viewed from the rear of the fryer), insert pin terminals into the corresponding pin-holes in the 6-pin connector. When all pin terminals have been fully inserted, close the connector by sliding the halves together until the tabs snap back into place (reverse procedure in Step 2).



Proper element-wire routing is essential to prevent wire chafing while raising and lowering elements.

7-5: REPLACE HEATING ELEMENT (cont.)

10. When replacing the left element (as viewed from the rear of the fryer), use the 9-pin connector, inserting the leads from the replacement element and closing the connector, see previous step.
11. Insert the connector(s) into the receptacle(s) on the rear of the contactor box, ensuring that the latches lock the connectors in place (see Step 9).
12. Install the temperature probe wires (marked for re-assembly) in the corresponding pin locations.
13. Reconnect the element spring.
14. Place the tilt housing cover over the tilt housing assembly and secure with screws.
15. Install covers and secure with screws.
16. Position fryer under exhaust hood.



Left element— 9-pin connector

Right element— 6-pin connector

7-6: REPLACE HIGH-LIMIT

1. Perform Procedure 7-4, Replace Temperature Probe, Steps 1-4.
2. Disconnect the wire harness containing the high-limit wires.
3. Use a pin-pusher to remove the two high-limit wires from the wire harness connector. For split-pot fryers, remove only the wires for the high-limit to be replaced. Mark each wire for re-assembly.
4. Remove the high-limit from the frypot using an open-end wrench or other suitable tool.
5. Apply Loc-Tite PST 567 sealant to the replacement high-limit threads.
6. Screw the replacement high-limit into the frypot and tighten securely. **DO NOT OVERTIGHTEN.**
7. Insert the replacement high-limit wires into the proper pin-holes in the connector. The same two pin-holes from which the defective high-limit wires were removed.
8. Reconnect the wire harness connector.
9. Install and secure the back covers.
10. Position the fryer under the exhaust hood.

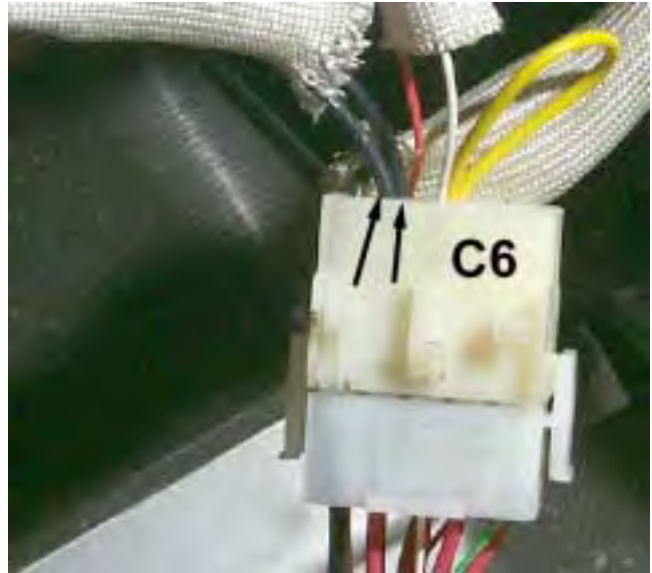

Use a pin-pusher to remove high-limit wires from connector

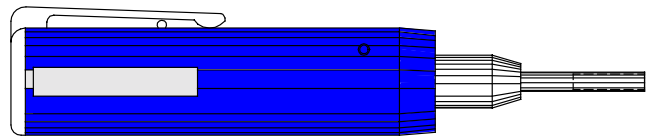

Pin Pusher— P/N 807-0928



Place tool here when removing and installing high-limit

7-7: REPLACE FRYPOT

1. Perform Procedure 7-4, Replace Temperature Probe, Steps 1-7.
2. Perform Procedure 7-1, Replace Computer/Controller, Steps 1-6.
3. Disconnect the wire harness containing the high-limit wires.
4. Use a pin-pusher to remove the high-limit wires from the wire harness connector.
5. Remove the high-limit from the frypot.
6. Disconnect the wire-harnesses connected to the contactor box.
7. Remove the screws securing the capping piece from the fryer. Remove the capping piece and set aside. It may be necessary to remove the wiring covers from the front of the contactor box.
8. If the fryer has a built-in filtration system, remove all the plumbing from the frypot, including rear-flush and square-drain plumbing.
9. Remove the screws securing the frypot to the front frame of the fryer.
10. Carefully lift the frypot from the cabinet.
11. Remove the drain valve from the old frypot and install on the new frypot.
12. Apply Loc-Tite Sealant PST 567 to the high-limit threads. Install the high-limit into the new frypot.
13. Disconnect the tilt plate springs from the old frypot.
14. Remove the securing screws from the tilt plate. Lift the tilt plate/heating element assembly from the old frypot and install on the new frypot.
15. Follow the preceding steps in reverse to install the new frypot into the fryer.
16. NOTE: Apply Loc-Tite Sealant PST 567 to all pipefittings prior to installation.

7-8: REPLACE CONTACTOR

1. Perform Procedure 7-4, Replace Temperature Probe, Steps 1-3.
2. Remove the screws securing the bottom and center rear access covers. Set the screws and covers aside.
3. If present, remove the screws securing the wiring covers to the front of the contactor box (**optional on old-style contactor boxes**). Set the screws and covers aside.
4. Disconnect the wire harnesses from the front and rear of the contactor box.



Screws securing wire cover to contactor box (optional on old-style contactor boxes)

5. Remove the screws securing the contactor box to the bottom frame of the fryer.
6. Pull the contactor box through the access opening in the rear of the fryer.
7. Remove the screws securing the contactor box cover. Set the screws and covers aside.



Location of screws securing contactor box to bottom frame

8. Remove all wiring connected to the contactor terminals inside the contactor box. Mark each wire for re-assembly.



Mark each wire for re-assembly, then remove all wiring connected to the contactor(s) to be replaced.

9. Remove the contactor mounting screws and remove the contactor.



Contactor mounting screws

10. Install the new contactor and connect the wiring removed in Step 8.
11. Install the contactor box by following the previous steps in reverse order.



Latching Contactor

Mercury (Heating)
Contactor

7-10: BUILT-IN FILTER SYSTEM SERVICE PROCEDURES

Filtration Problem Resolution

One of the most common errors is placing the filter paper on the bottom of the filter pan rather than over the filter screen.

⚠ CAUTION
ENSURE THAT FILTER SCREEN IS IN PLACE PRIOR TO FILTER PAPER PLACEMENT AND FILTER PUMP OPERATION. IMPROPER SCREEN PLACEMENT IS THE MAJOR CAUSE OF FILTER SYSTEM MALFUNCTION

Whenever the complaint is “the pump is running, but no oil is being filtered,” check the installation of the filter paper, and ensure that the correct size is being used. While you are checking the filter paper, verify that the O-ring on the bottom of the filter pan is present and in good condition. A missing or worn o-ring allows the pump to take in air and decreases its efficiency.

If the pump motor overheats, the thermal overload will trip and the motor will not start until it is reset. If the pump motor does not start, press the red reset switch (button) located on the rear of the motor.



If the pump starts after resetting the thermal overload switch, then something is causing the motor to overheat. A major cause of overheating is when several frypots are filtered sequentially at one time, thus overheating the pump and motor. Allow the pump motor to cool at least 30 minutes before resuming operation.

Pump overheating can be caused by:

- Solidified shortening in the pan or filter lines,

Or

- Attempting to filter unheated oil or shortening.

Cold oil and shortening are more viscous, causing the pump motor to loadup and overheat.

7-10: BUILT-IN FILTER SYSTEM SERVICE PROCEDURES (cont.)

If the motor runs but the pump does not, there is a blockage in the pump. Incorrectly sized or installed paper/pads will allow food particles and sediment to pass through the filter pan and into the pump. When sediment enters the pump, the gears bind, causing the motor to overload, again tripping the thermal overload. Solidified shortening in the pump will also cause it to seize, with the same result.

A pump seized by debris or hard shortening can usually be freed by manually moving the gears with a screwdriver or other instrument.

Disconnect power to the filter system.

Remove the input plumbing from the pump.

Use a screwdriver to manually turn the gears, in which:

- Turning the pump gears in reverse will release a hard particle.
- Turning the pump gears forward will push softer objects and solid shortening through the pump and allow free movement of the gears.

Incorrectly sized or installed paper/pads will also allow food particles and sediment to pass through and clog the suction tube on the bottom of the filter carriage. Particles large enough to block the suction tube may indicate that the crumb tray is not being used.

Pan blockage can also occur if shortening is left in the pan and allowed to solidify. The heater strip on the suction tube is designed to prevent residual shortening from solidifying in the tube. Heater strips do not prevent residual shortening from solidifying in the pan.

Blockage removal can be accomplished by forcing the item out with an auger or drain snake. Compressed air or other pressurized gases should not be used to force out the blockage.

For FootPrint III systems built before October, 1999, all heater tapes are wired directly into the line VAC source (see wiring diagram, page 7-14). They remain energized as long as the unit is plugged in. In systems built in October, 1999 and later, oil return line heater tapes have been eliminated. In these units, the only heater tape used is on the suction tube and pump. This tape is still wired directly into the line voltage. A pair of vacuum-breaking solenoids is wired into the 24 VAC circuit.

The redesigned FPIII is distinguished from original-design units by the absence of casters on the filter base assembly. The redesign incorporated an improved oil return system that allows oil/shortening to drain back to the filter pan when the filter system is turned off, eliminating the need for most heated oil return components.

FREEING A SEIZED PUMP

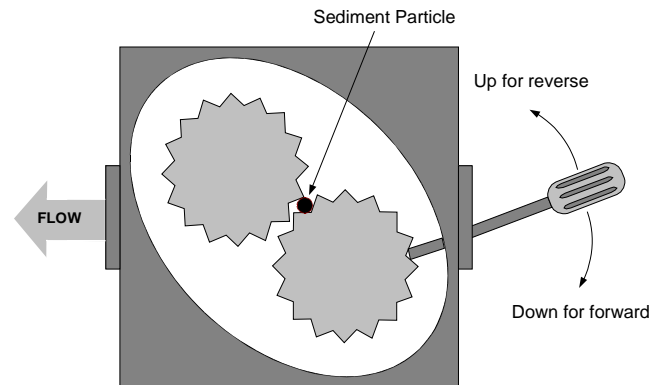

7-10: BUILT-IN FILTER SYSTEM SERVICE PROCEDURES (cont.)

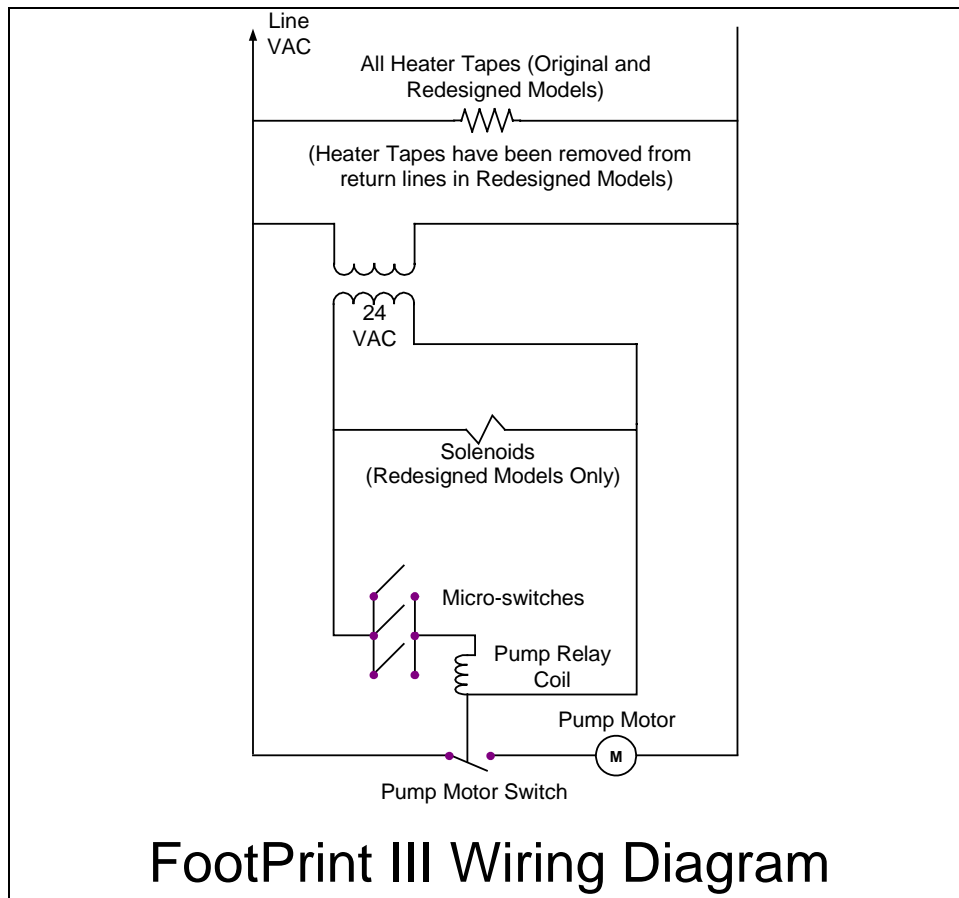

Operation of the redesigned FP-III system is the same as for the original design.

| ORIGINAL VS REDESIGNED FP-III FILTRATION SYSTEM | |
|---|---|
| Original System | Redesigned System |
| Return lines and manifolds wrapped with silicone strip heaters and aluminum tape. | No heater strips or aluminum tape on return lines. |
| Filter base assembly connected to unit with a black, heated return hose beneath the filter. | Non-heated Teflon hose with a swivel joint connects the filter base assembly to the unit above the filter. |
| Filter base assembly equipped with swivel casters. | Filter base assembly has no casters. |
| Operator-removable filter base assembly. (Filter base assembly stoplocks in cabinet can be rotated to remove tray.) | Filter base assembly is not removable except by a qualified service technician. (Filter base assembly stoplocks fitted with a screw and nut to prevent filter removal.) |
| Oil/shortening remains in return lines when filter system is turned off. | Oil/shortening gravity-drains back to the filter pan when filter system is turned off, leaving no oil or shortening in return lines. |
| Return drain-manifolds are constructed with pipe nipples, elbows and other plumbing components. | Return drain manifolds are one-piece with an in-line solenoid valve to facilitate gravity drain-back to filter pan. |

7-11: ELECTRIC INTERFACE BOARD DIAGNOSTIC CHART

The following diagram and charts provide ten quick system checks that can be performed using only a multimeter.

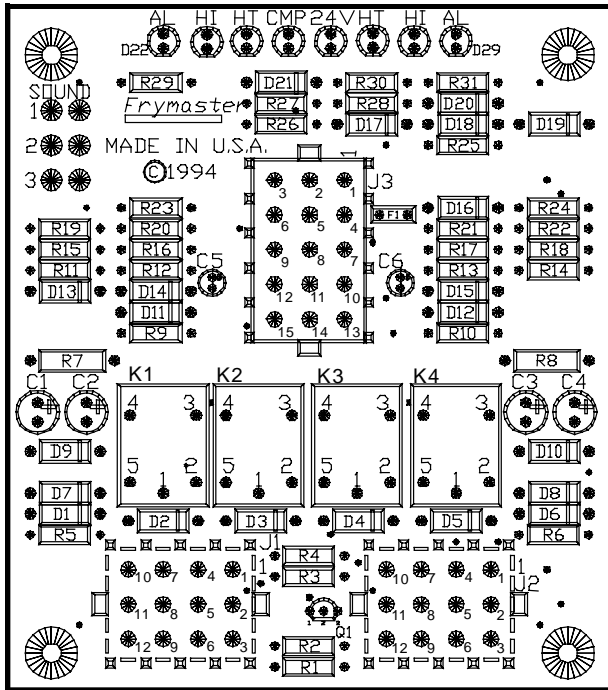

Note: The sealed relays are not replaceable. If a relay fails the interface board must be replaced.

Diagnostic LED Legend

- CMP indicates power from 12V transformer
- 24 indicates power from 24V transformer
- HI (RH) indicates output (closed) from right Latch relay
- HI (LH) indicates output (closed) from left Latch relay
- HT (RH) indicates output from right Heat relay
- HT (LH) indicates output from left Heat relay
- AL (RH) indicates output (open) from right Latch relay
- AL (LH) indicates output (open) from left Latch relay

| Meter Setting | Test | Pin | Pin | Results |
|---------------------------|---------------|----------|----------|------------|
| 12 VAC Power | 50 VAC Scale | 1 of J2 | 3 of J2 | 12-16 VAC |
| 24 VAC Power | 50 VAC Scale | 2 of J2 | Chassis | 24-30 VAC |
| *Probe Resistance (RH) | R X 1000 OHMS | 11 of J2 | 12 of J2 | See Chart |
| *Probe Resistance (LH) | R X 1000 OHMS | 3 of J1 | 2 of J1 | See Chart |
| Hi-Limit Continuity (RH) | R X 1 OHMS | 7 of J2 | 4 of J2 | 0 - OHMS |
| Hi-Limit Continuity (LH) | R X 1 OHMS | 4 of J1 | 7 of J1 | 0 - OHMS |
| Latch Contactor Coil (RH) | R X 1 OHMS | 8 of J2 | Chassis | 3-10 OHMS |
| Latch Contactor Coil (LH) | R X 1 OHMS | 5 of J1 | Chassis | 3-10 OHMS |
| Heat Contactor Coil (RH) | R X 1 OHMS | 9 of J2 | Chassis | 18-25 OHMS |
| Heat Contactor Coil (LH) | R X 1 OHMS | 6 of J1 | Chassis | 18-25 OHMS |

***Disconnect 15-Pin harness from the computer/controller before testing the probe circuit.**

COMMON ELECTRIC McDONALD'S H14 SERIES— FULL-VAT

7-12: WIRING DIAGRAMS, SIMPLIFIED

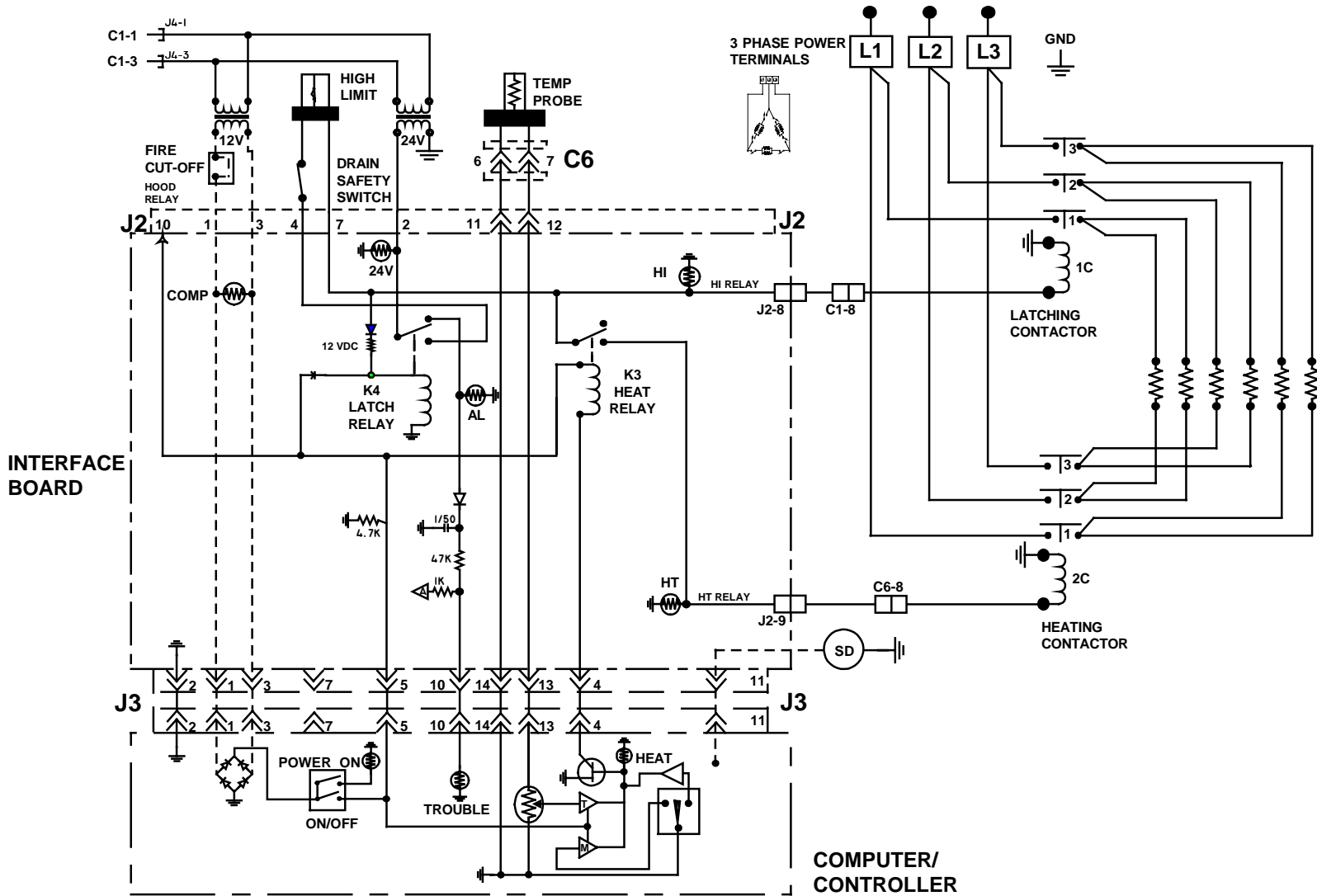

7-17

COMMON ELECTRIC McDONALD'S H14 SERIES— DUAL-VAT

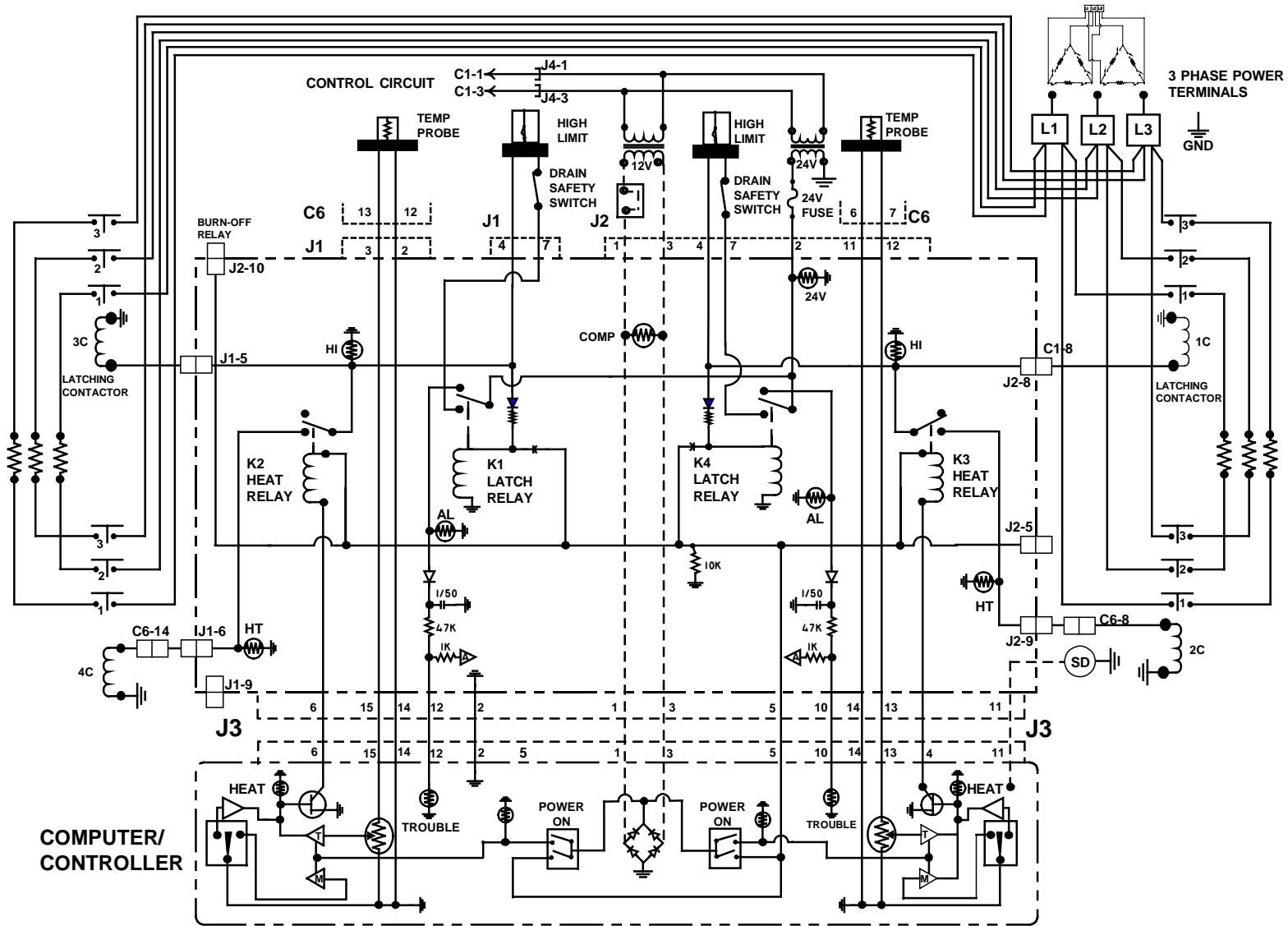

81-7

COMMON ELECTRIC McDONALD'S H14 SERIES- FULL-VAT— EXPORT WYE

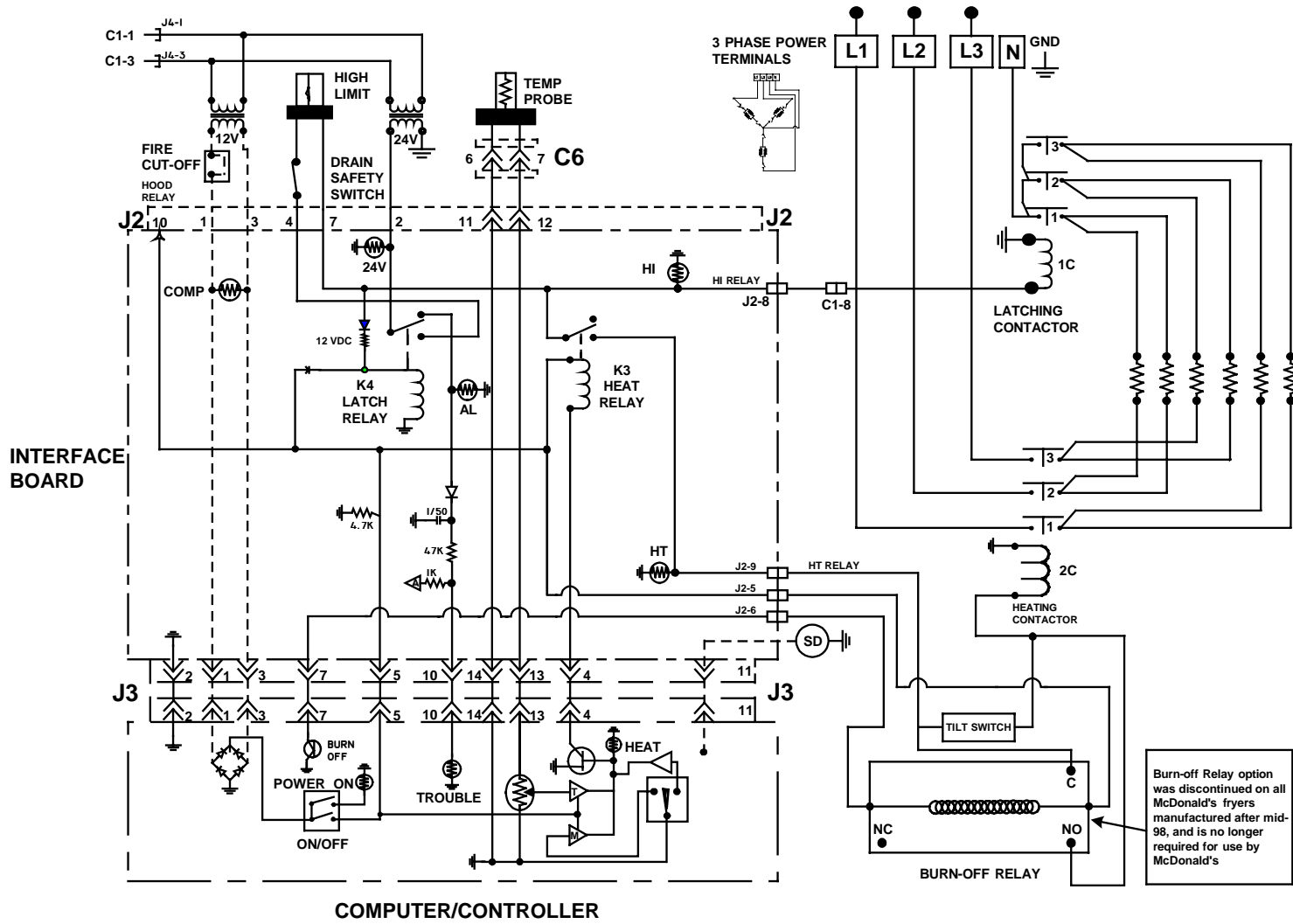

7-1-19

COMMON ELECTRIC McDONALD'S H14 SERIES- DUAL-VAT— EXPORT WYE

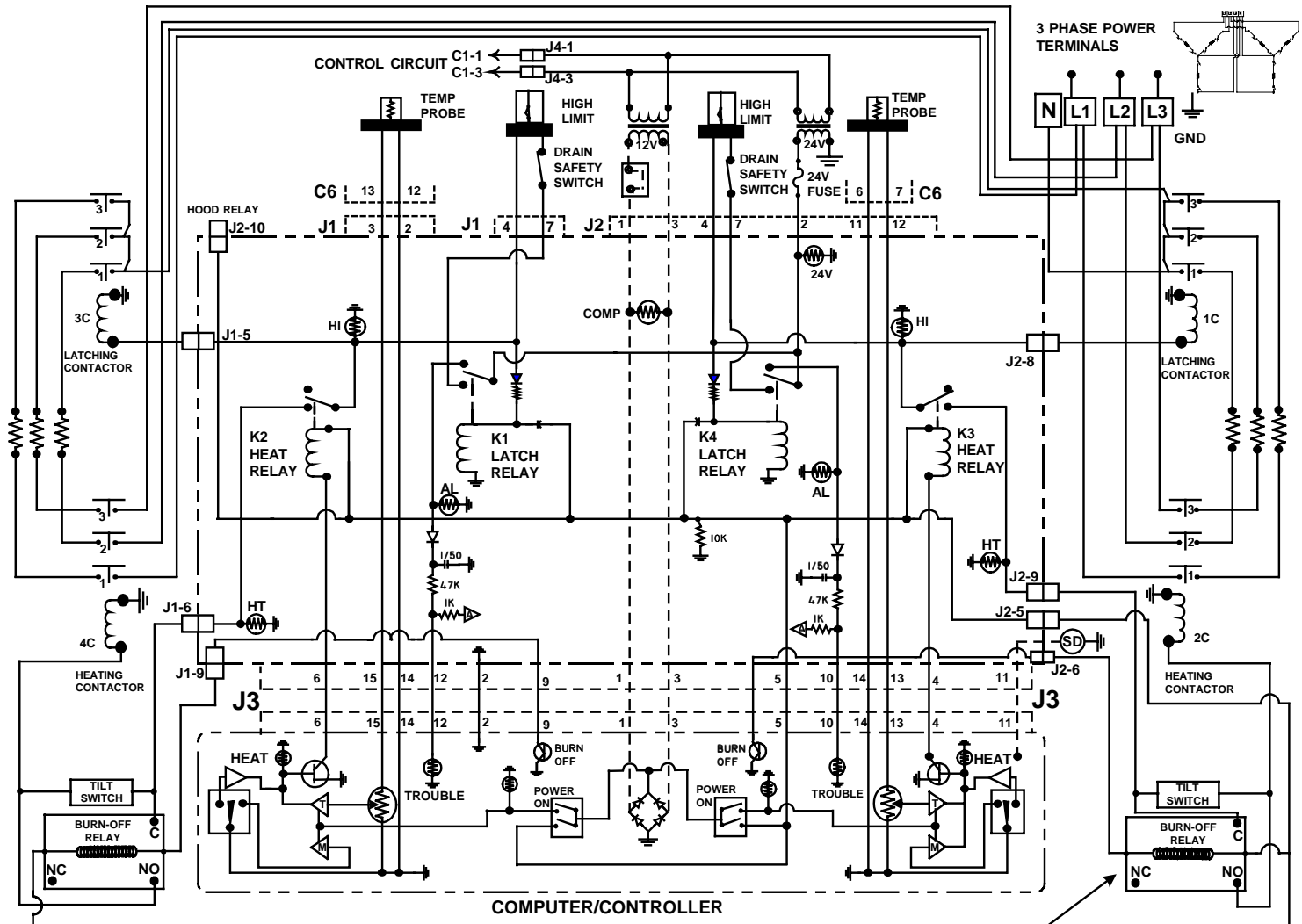

Burn-off Relay option was discontinued on all McDonald's fryers manufactured after mid-98, and is no longer required for use by McDonald's

McDonald's European Community (CE) (Prior To 9/98)

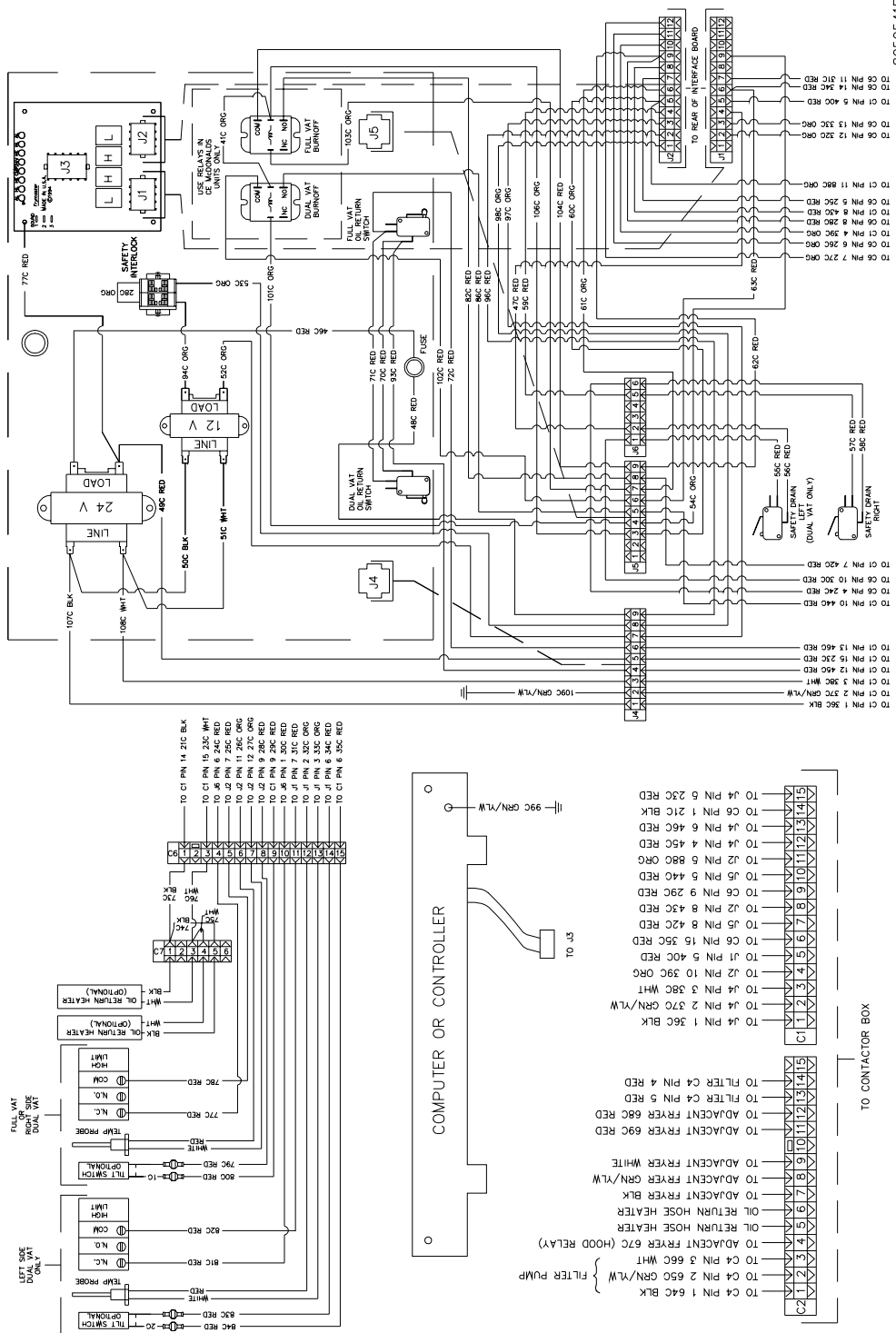

8050641E

McDonald's Domestic Contactor

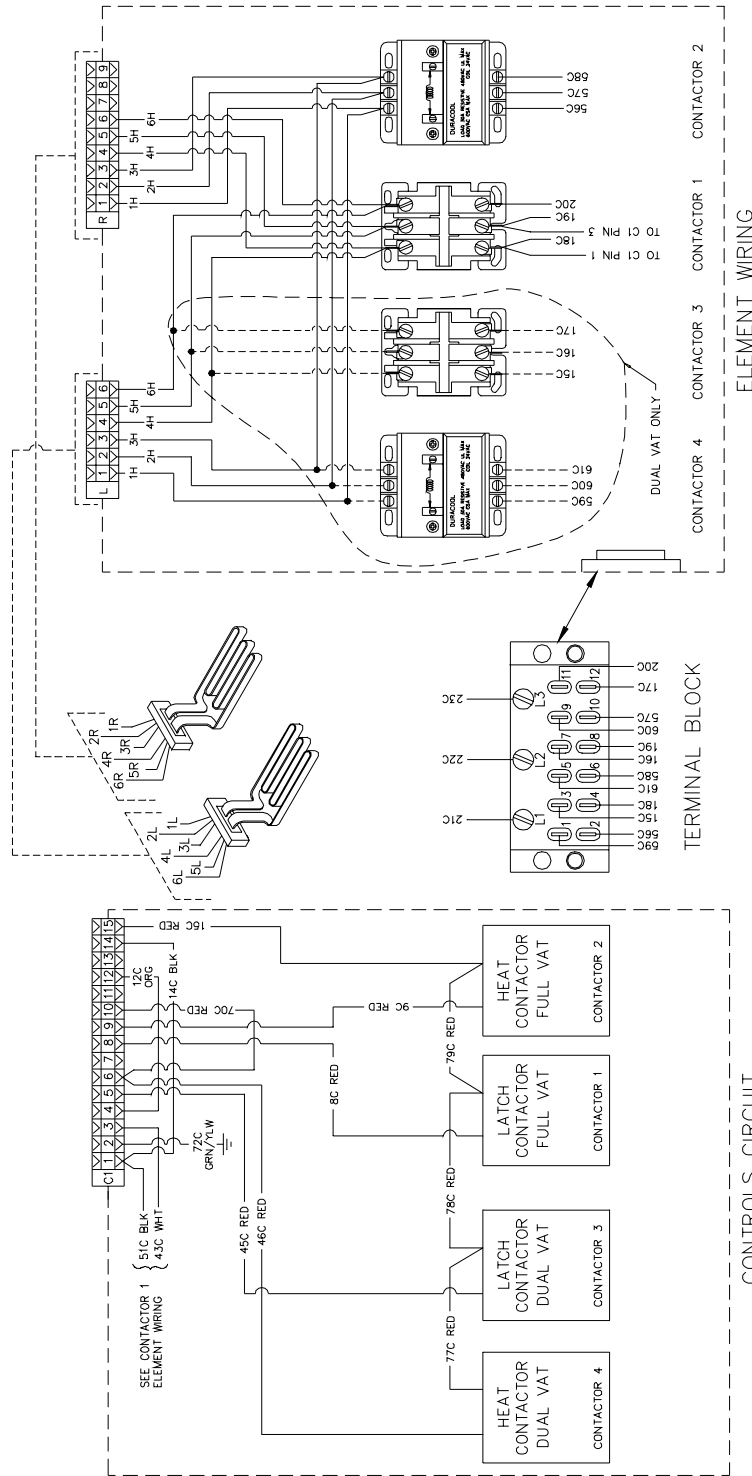

8051190A

McDonald's European Community (CE) XBIH14 Contactor

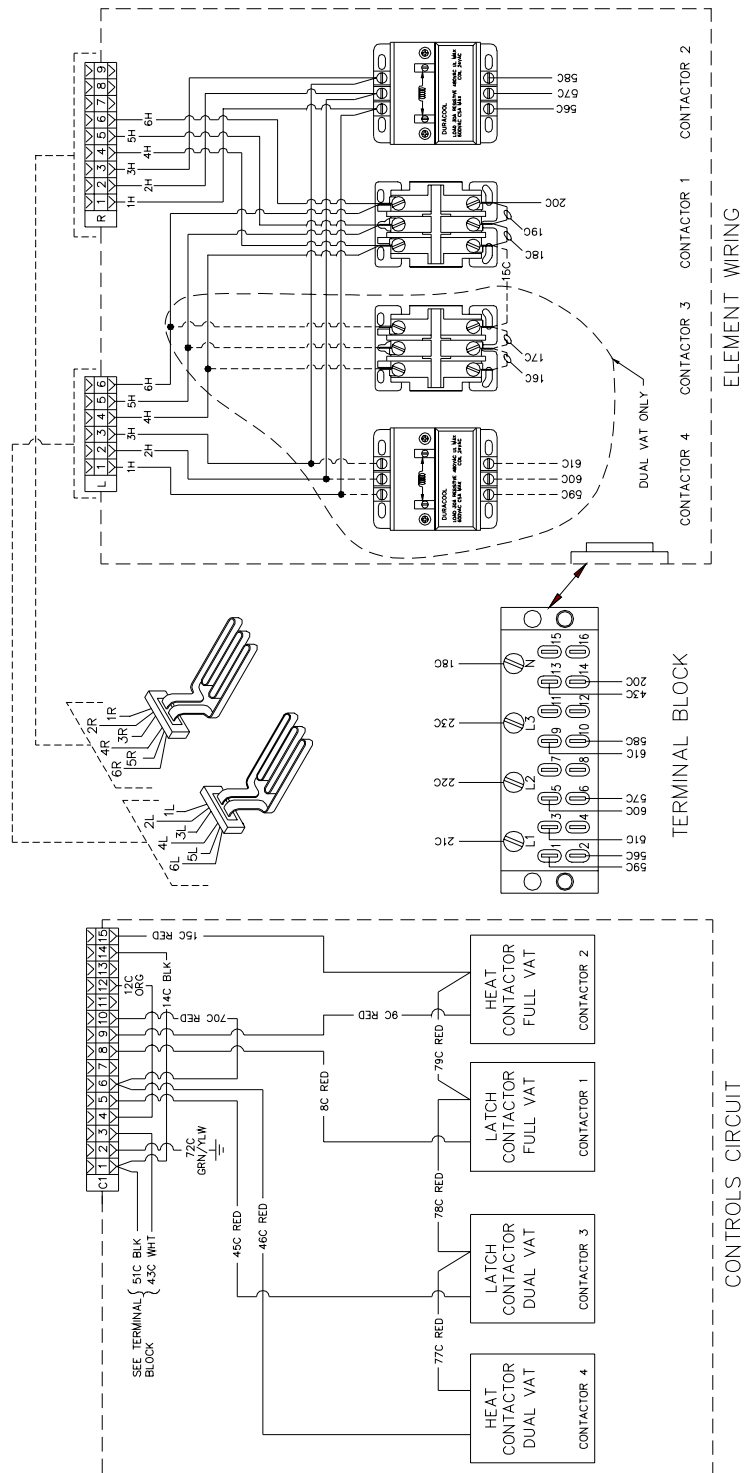

McDonald's 440/480V Contactor

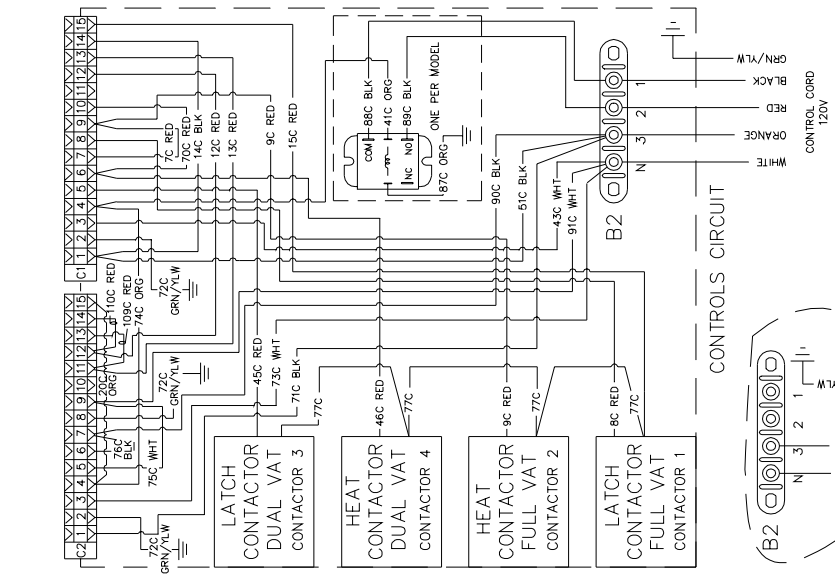
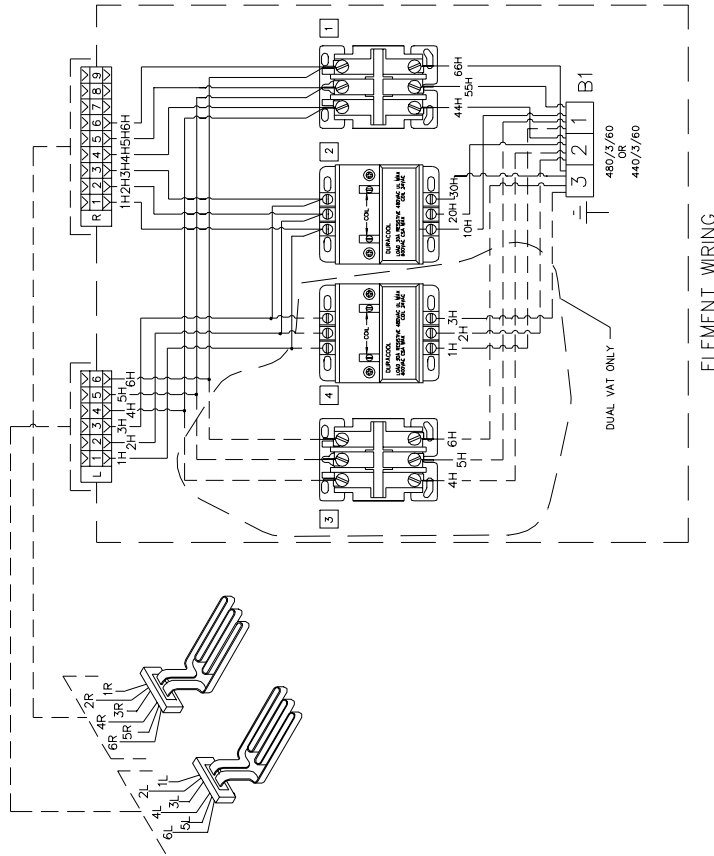

8050881B

McDonald's Delta CSA Contactor

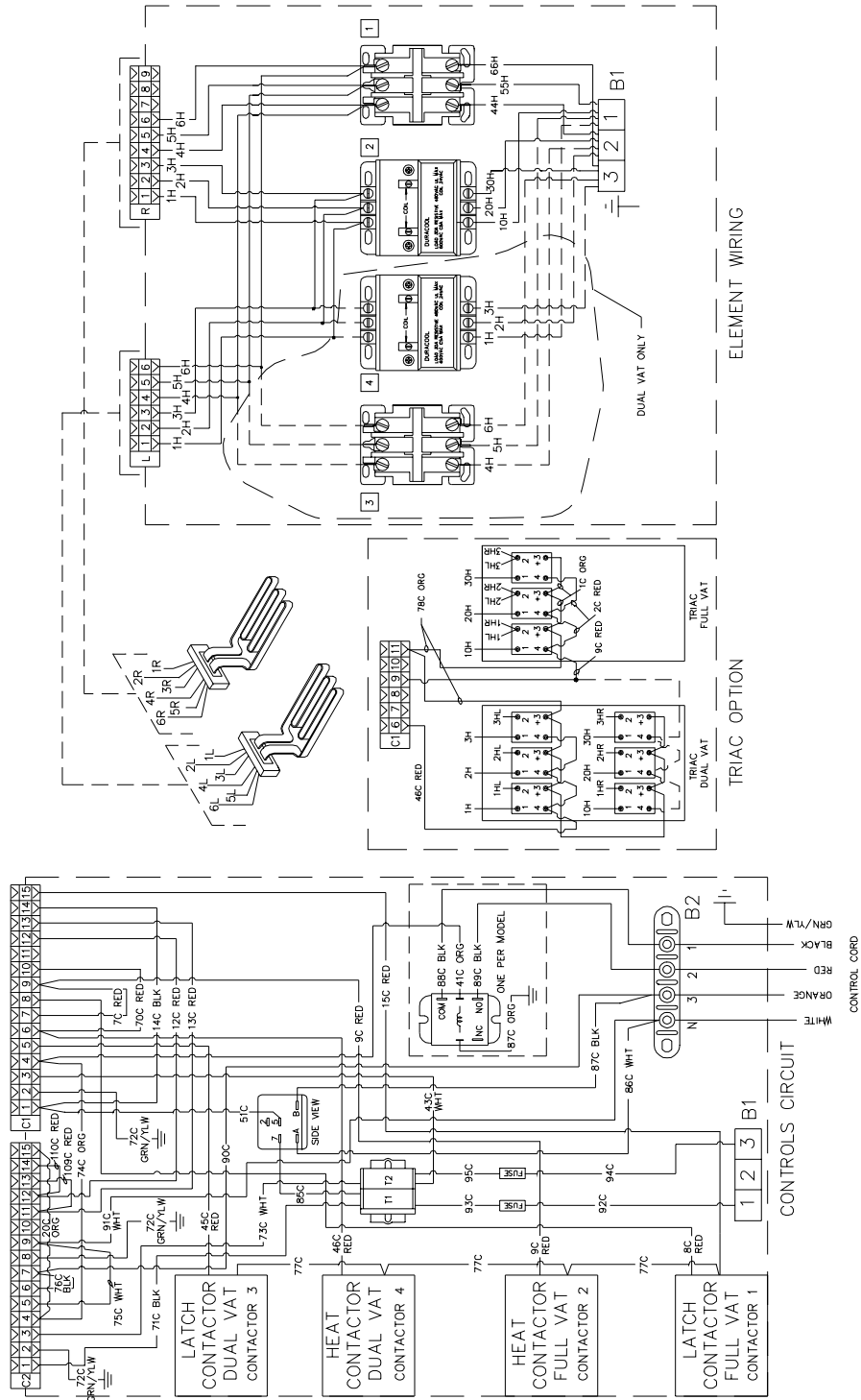

8050900C

McDonald's Domestic Control Cord

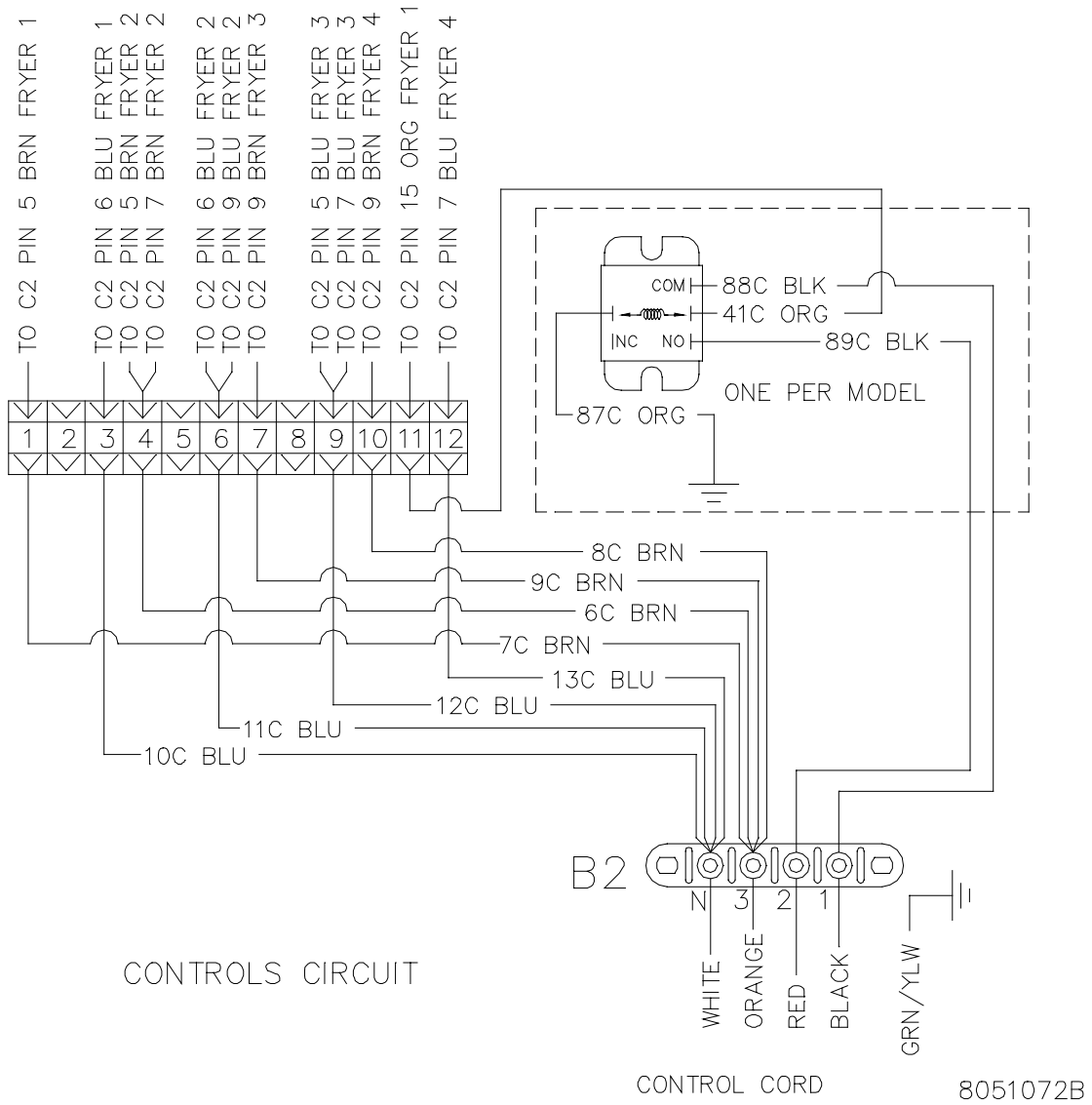

McDonald's English Control Cord

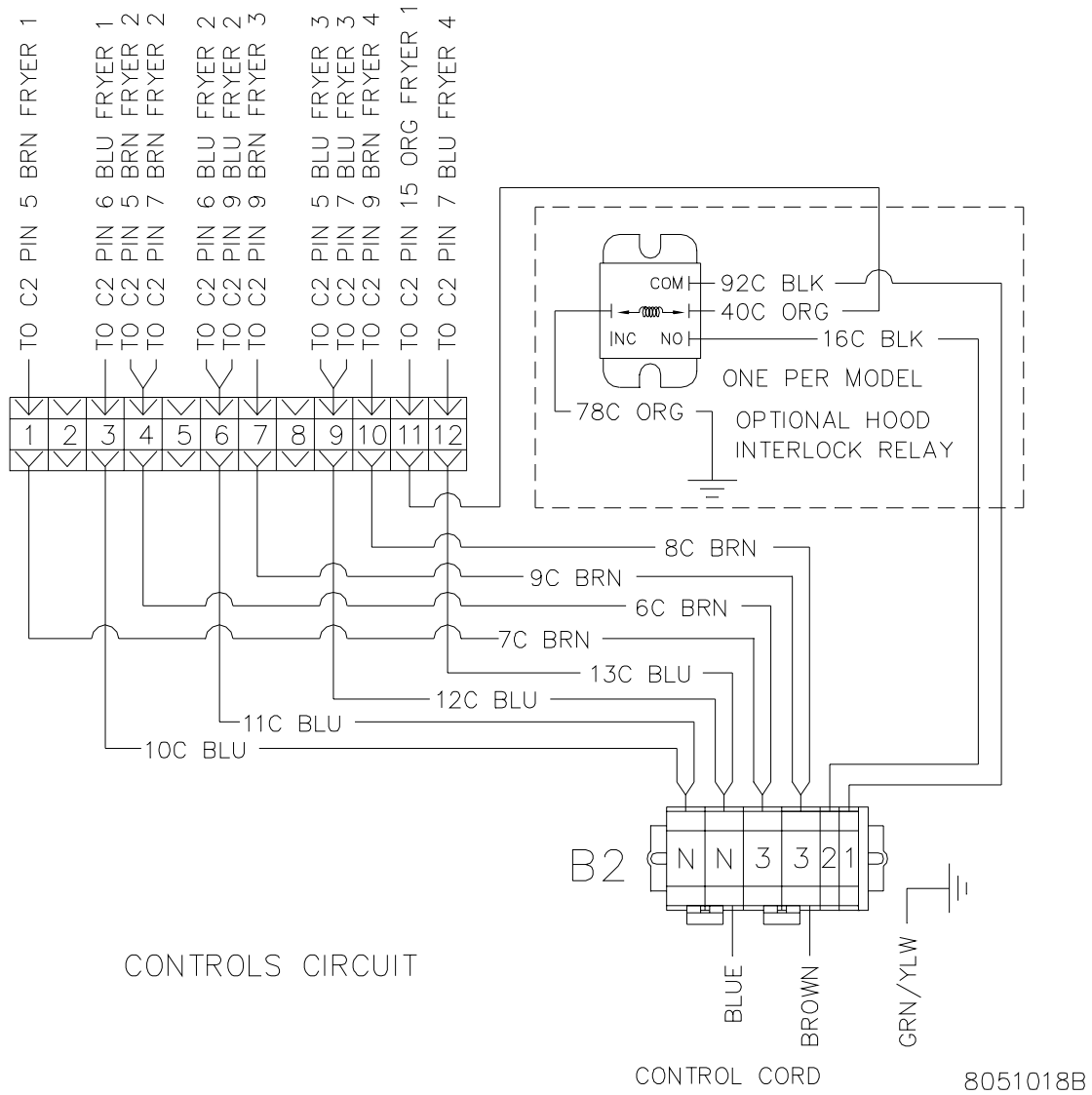

7-13: WIRING DIAGRAMS, FILTER UNITS

Footprint III, Early Configuration.

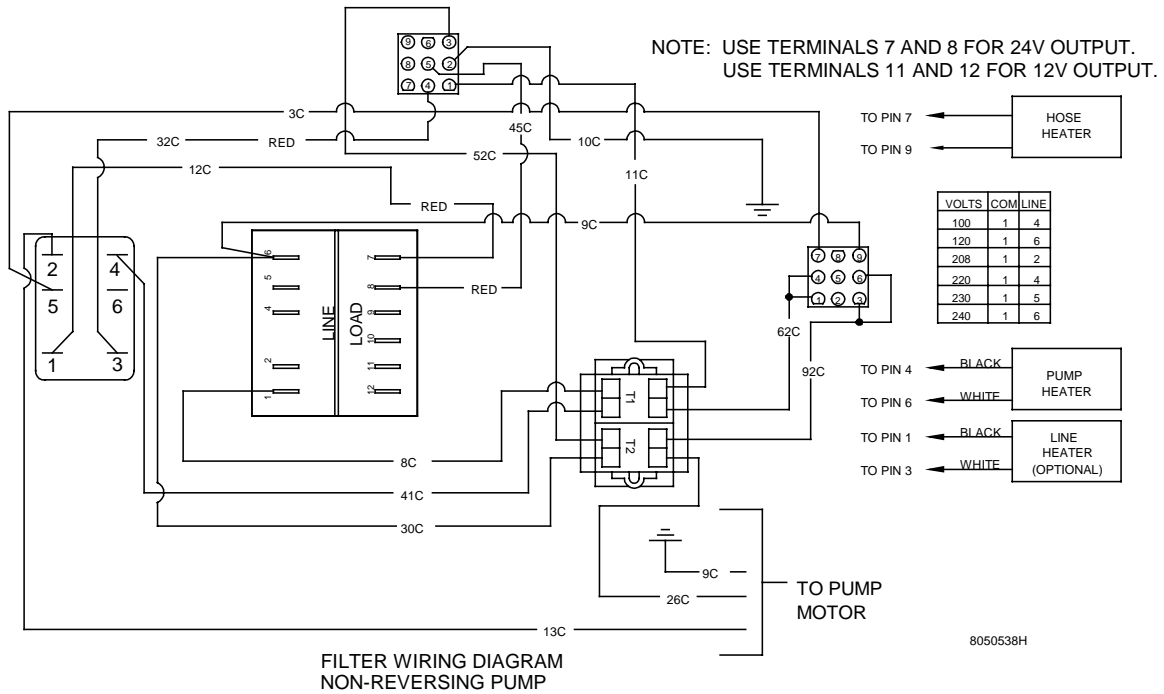

Footprint III, Late Configuration

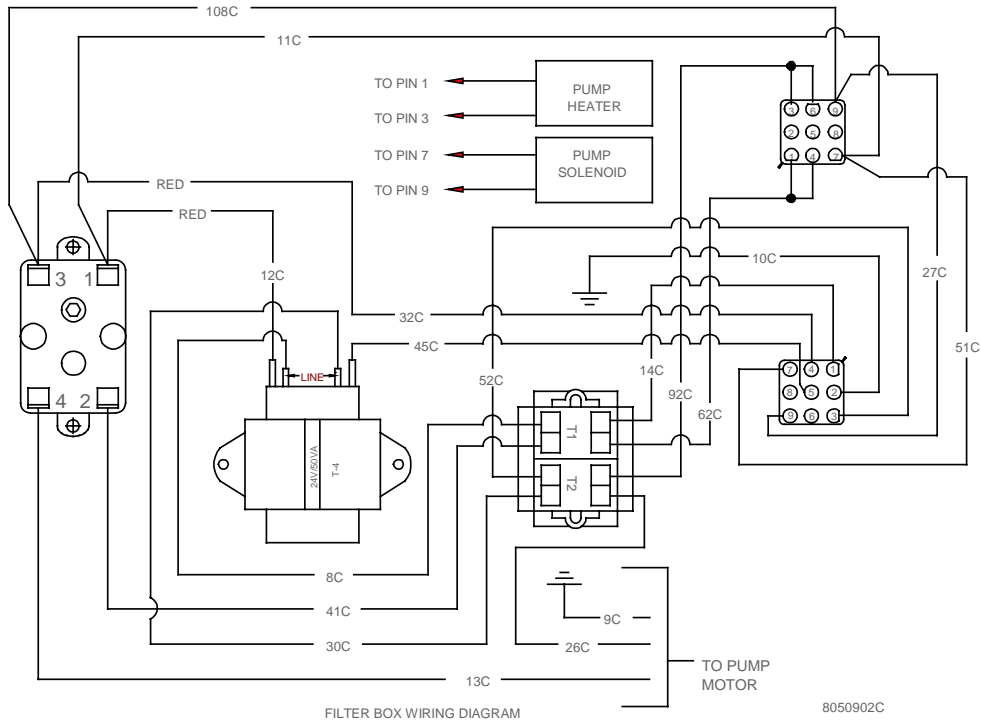

H14 SERIES ELECTRIC FRYERS

CHAPTER 8: PARTS LIST

8.1 Accessories

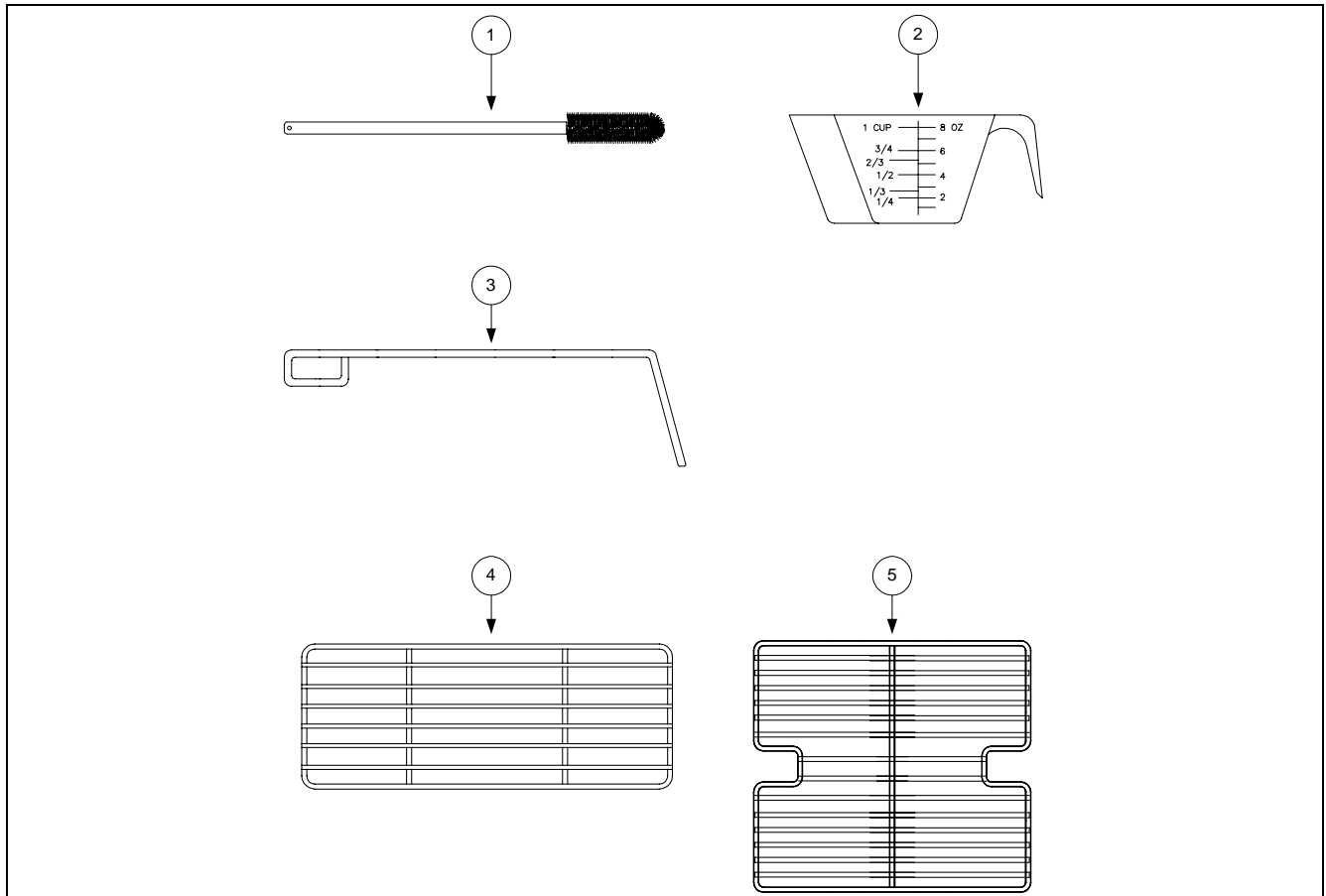

| ITEM | PART # | COMPONENT |
|------|----------|--|
| 1 | 803-0209 | Brush, FV/DV Frypot |
| 2 | 803-0046 | Cup, Measuring, Plastic, #1040 |
| 3 | 803-0197 | Fryer Friend 27" (Clean-out Rod) |
| 4 | 803-0106 | Rack, Electric Dual-Vat Basket Support |
| 5 | 803-0132 | Rack, H50 Full-Vat With Probe Guard Basket |
| * | 803-0002 | Carton, Filter Powder |
| * | 803-0170 | Filter Pack- 100 Sheets |
| * | 803-0219 | Pad, McDonald's FPIII Universal Filter |
| * | 806-0486 | Cover, Frypot |

* Not Illustrated

8.2 Cabinet Assemblies and Component Parts

8.2.1 MH/BIH114 Cabinet Assembly, Single FootPrint

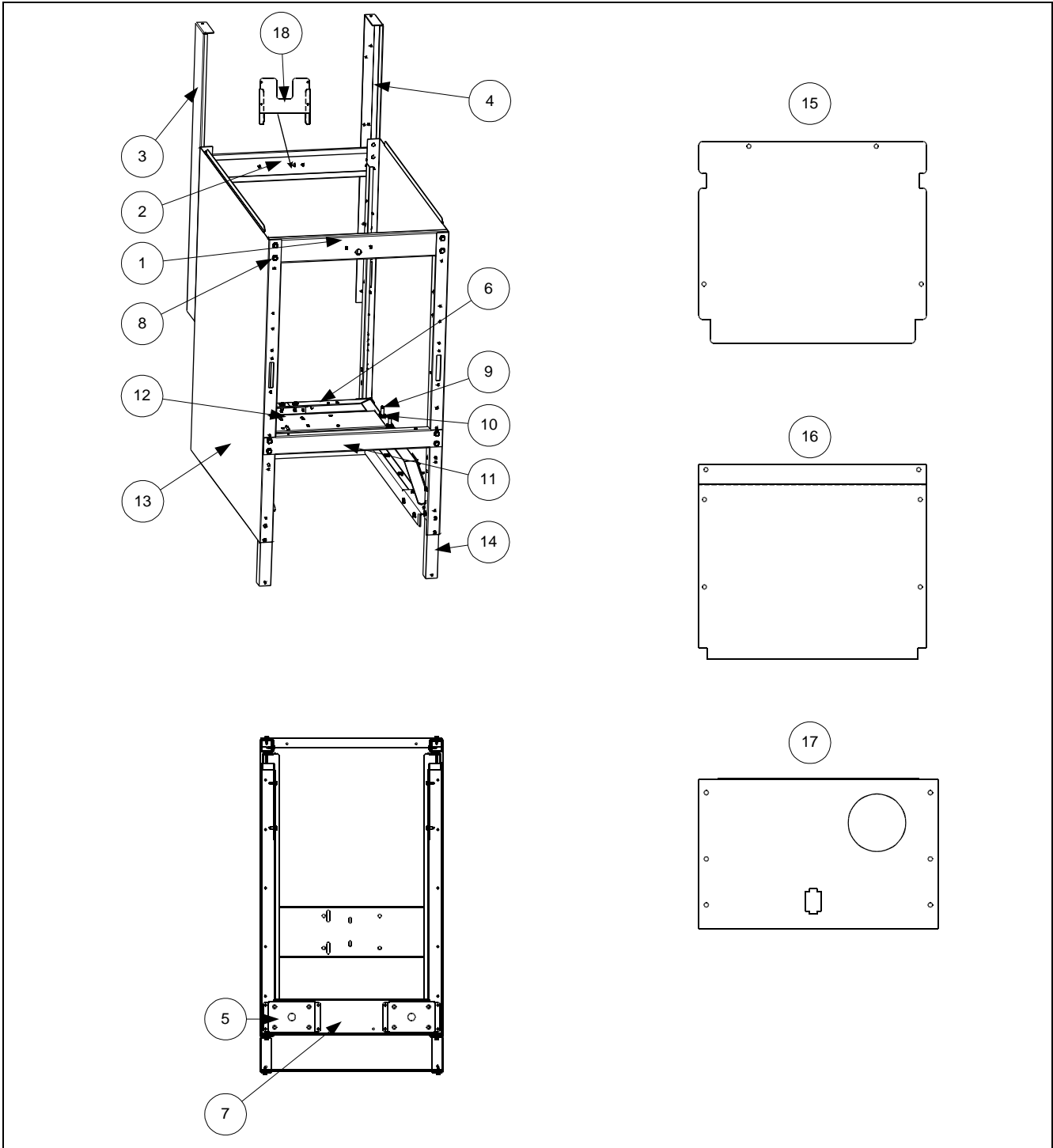

| ITEM | PART # | COMPONENT |
|-------------|---------------|--|
| 1 | 200-0129 | Rail, Top Front Single |
| * | 806-4910SP | Rail, Top Front Single (BIH114 prior to 1/99) |
| 2 | 200-0130 | Brace, Rear Horizontal |
| 3 | 201-0137 | Upright- rear enclosure |
| 4 | 202-0137 | Upright- rear enclosure |
| 5 | 806-8059 | Pad, Leg Assembly |
| 6 | 806-8062 | Rail, Pan Filter Assembly |
| 7 | 806-8935SP | Base Assembly, FM 3-PIECE |
| | 900-5313 | Channel, CE FM Single Rear |
| | 901-5316 | Channel, CE FM LT Single Side |
| | 902-5316 | Channel, CE FM RT Single Side |
| * | 806-7003SP | Base Assembly, Single Common Electric |
| 8 | 826-1374 | Screw, #10-1/2 Hex Head (Qty: 25) |
| 9 | 826-1334 | Bolt, 1/4-20 X 1 1/4 Hex Head (Qty: 5) |
| 10 | 826-1368 | Nut, Flange 1/4-20 Serrated (Qty: 10) |
| 11 | 900-4391SP | Brace, Cabinet Front |
| * | 900-4393SP | Brace, Cabinet Front (BIH114 prior to 1/99) |
| * | 900-2733 | Brace, Contactor Box, Front, N/F |
| * | 900-2734 | Brace, Support Contactor Box, Common Electric, N/F |
| 12 | 900-8582 | Mount, Motor Single FootPrint |
| 13 | 910-2456SP | Side , Cabinet |
| * | 911-9314SP | Side, Cabinet (BIH114 prior to 1/99) |
| * | 912-9314SP | Side, Cabinet (BIH114 prior to 1/99) |
| 14 | 910-8659 | Leg, Cabinet Front, Single FootPrint |
| * | 910-7925 | Leg, Cabinet Front (BIH114 prior to 1/99) |
| 15 | 900-2717SP | Back, Upper Cabinet |
| * | 910-2912 | Back, Upper Cabinet (BIH114 prior to 1/99) |
| 16 | 900-5141 | Back, Center Cabinet |
| 17 | 900-8449 | Back, Lower Cabinet |
| * | 910-2911 | Back, Lower Cabinet (BIH114 prior to 1/99) |
| 18 | 900-9585 | Heat Shield, Wire, Common Electric |

8.2.2 MH/BIH214, 314, 414, 514 Cabinet Assemblies

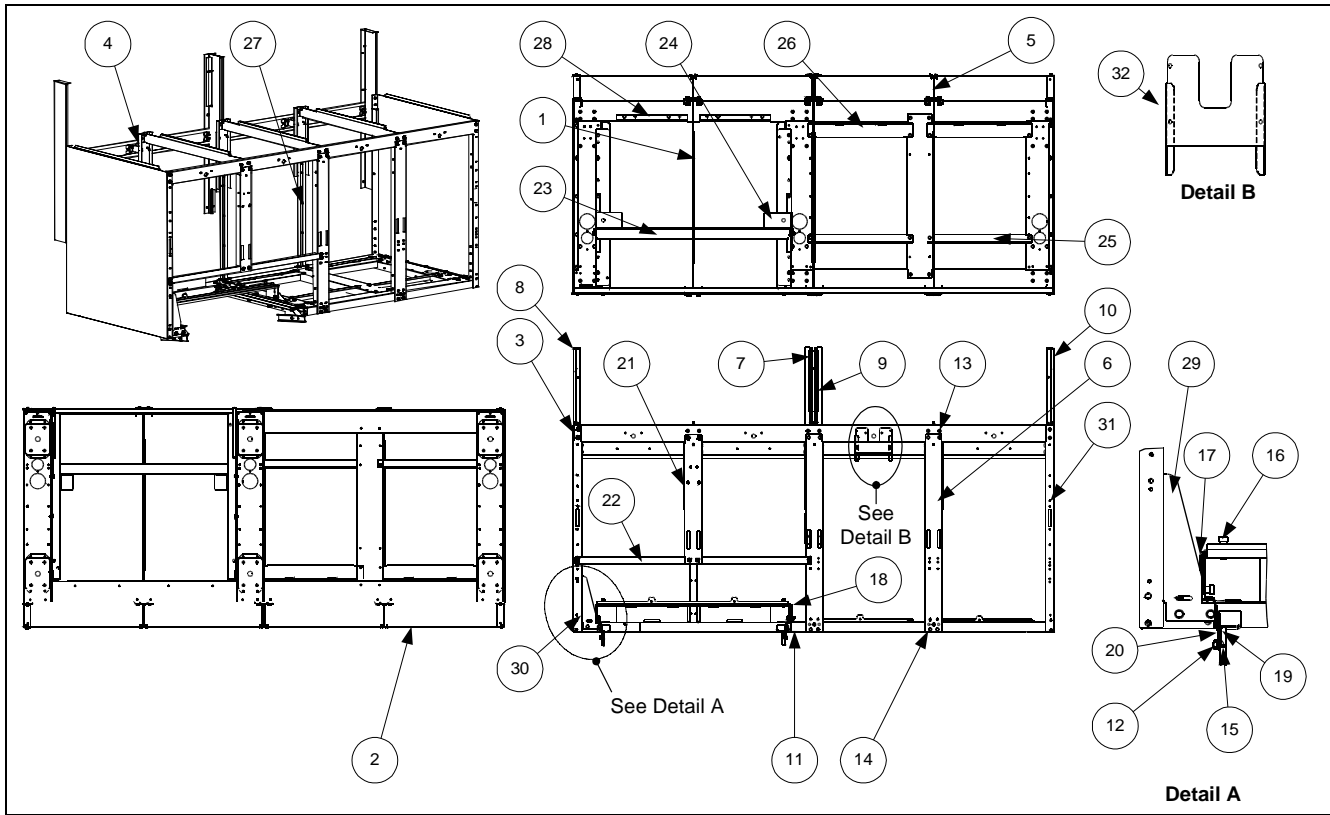

| ITEM | PART # | COMPONENT |
|------|------------|--|
| 1 | 200-0076 | Divider, Cabinet, Common Electric |
| 2 | 200-0084 | Brace, Rear Horizontal, 2 Battery (Quad and Double) |
| * | 200-0085 | Brace, Rear Horizontal, 3 Battery (Triple) |
| 3 | 200-0091 | Rail, Top- Quad Cabinet |
| * | 200-0072 | Rail, Top- Triple Cabinet |
| * | 200-0081SP | Rail, Top- Double Cabinet |
| 4 | 200-0092 | Support, Rear, Common Electric |
| 5 | 200-0126 | Brace, Rear Support |
| 6 | 200-0138 | Door Post, Common Electric (Triple, Quad w/filter; Double, Triple, Quad N/F) |
| 7 | 201-0093 | Enclosure, Rear Upright with Hole (Quad Only) |
| 8 | 201-0137 | Upright, Rear Enclosure, Common Electric |
| 9 | 202-0093 | Enclosure, Rear Upright with Hole (Quad Only) |
| 10 | 202-0137 | Upright, Rear Enclosure, Common Electric |
| 11 | 806-7005SP | Base, Filter Assembly, Common Electric- Quad |
| * | 806-6513SP | Base, Filter Assembly, Common Electric- Triple |
| * | 806-6511SP | Base, Filter Assembly, Common Electric- Double |
| * | 806-6997SP | Base Assembly, Common Electric N/F- Double |
| * | 806-6999SP | Base Assembly, Common Electric N/F- Triple |
| * | 806-7001SP | Base Assembly, Common Electric N/F- Quad |
| 12 | 826-1376 | Nut, 10-32 (Qty: 10) |

| ITEM | PART # | COMPONENT |
|-------------------|---------------|---|
| 13 | 826-1374 | Screw, #10 ½-Inch (Qty: 25) |
| 14 | 809-0413 | Spacer, Door Post (Quad and Triple Only) |
| 15 | 809-0422 | Screw, Shoulder- 10-32 x .40 |
| 16 | 809-0538 | Bolt, Shoulder- ¼-20 x 3/8 |
| 17 | 823-2290 | Front Bridge Support, Left |
| 18 | 823-2291 | Front Bridge Support, Right |
| 19 | 900-1957 | Lock Filter |
| 20 | 900-1959 | Bracket, Mounting, Filter Lock |
| 21 | 900-2463 | Post, Center Door, Common Electric |
| 22 | 900-2464SP | Brace, Lower, Front Horizontal, Common Electric |
| 23 | 900-2514 | Bridge, Common Electric |
| 24 | 900-2653 | Plate, Swivel, Common Electric |
| 25 | 900-2718 | Brace, Contactor, Front, Common Electric w/Filter-Quad |
| * | 200-0078 | Brace, Contactor, Front, Common Electric [(w/Filter-Triple), N/F- Quad) |
| * | 200-0075 | Support, Contactor, Front, Common Electric N/F |
| 26 | 900-2720 | Brace, Contactor, Rear, Common Electric-Quad |
| * | 200-0077 | Brace, Contactor, Rear, Common Electric [(w/Filter-Triple), N/F- Quad) |
| * | 200-0074 | Support, Contactor, Rear, Common Electric N/F |
| 27 | 900-2861SP | Support, Bottom, Common Electric |
| 28 | 900-5988 | Support, Rear, Bridge Filter, Common Electric |
| 29 | 901-1810 | Gusset, Cabinet, Left |
| * | 902-1810 | Gusset, Cabinet, Right (BIH214 Only) |
| 30 | 901-1948 | Channel, Side Support |
| 31 | 910-2456SP | Cabinet Side, Common Electric |
| * | 900-8452 | Back, Lower Quad |
| * | 900-8451 | Back, Lower Triple |
| * | 900-8450 | Back, Lower Double |
| * | 900-5145 | Back, Center Triple |
| * | 900-5143 | Back, Center Double |
| * | 900-2511 | Back, Upper Triple |
| * | 900-2465 | Back, Upper Double |
| 32 | 900-9585 | Heat Shield, Wire, Common Electric |
| * Not Illustrated | | |

8.3 Casters, Legs and Associated Hardware

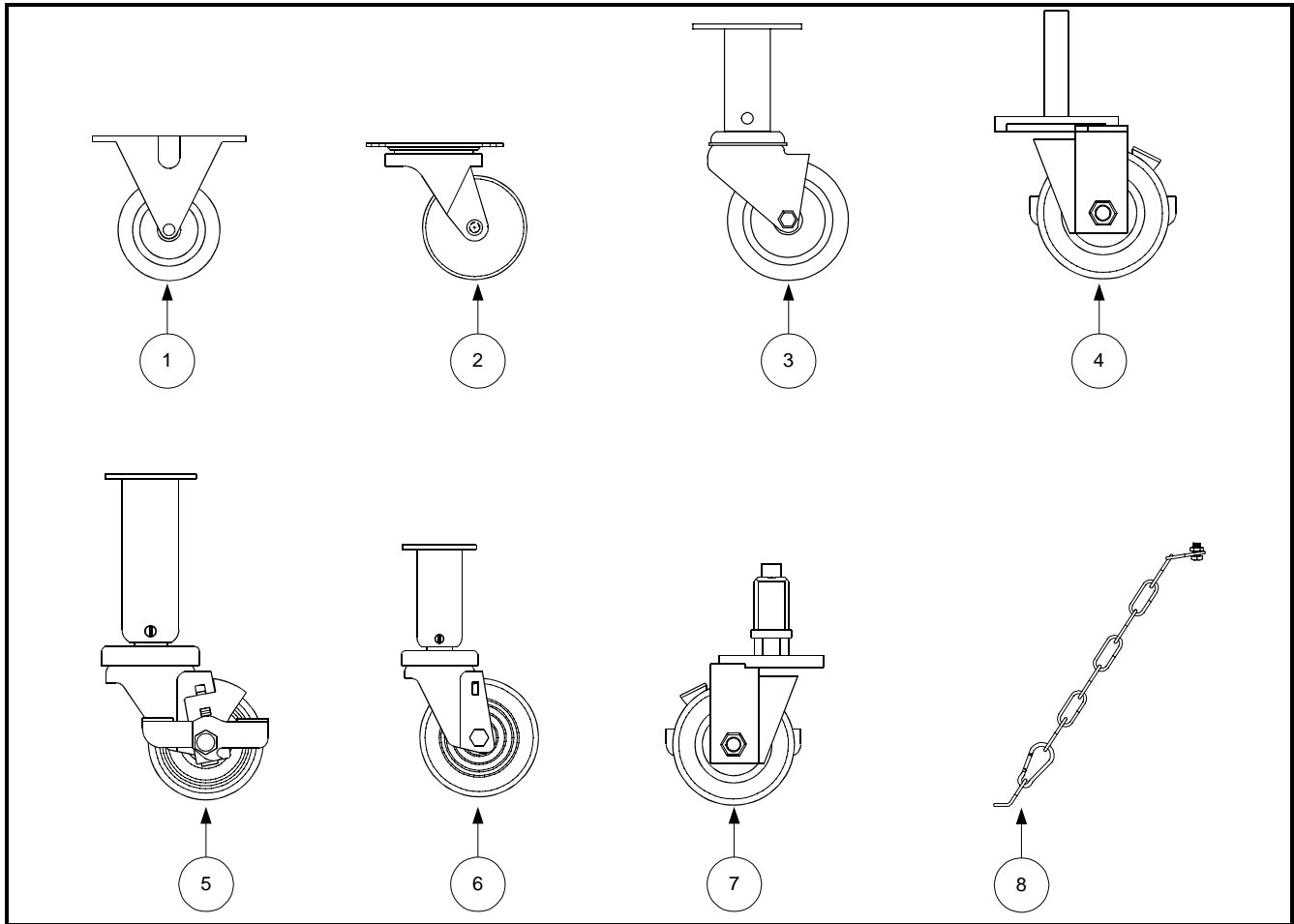

| ITEM | PART # | COMPONENT |
|------|----------|---|
| 1 | 810-0005 | Caster, Rigid |
| 2 | 810-0006 | Caster, Swivel-Rokite |
| 3 | 810-0327 | Caster, Adjustable, Without Brake |
| 4 | 810-1565 | Caster, Stud, Single FP 3", With Lock |
| 5 | 810-0944 | Caster, Adjustable 3" With Brake |
| 6 | 812-1326 | Caster W/A, 152-2 Adjustable With Brake |
| 7 | 823-2844 | Caster W/A, Front Common Electric, Single FootPrint |
| 8 | 826-0900 | Chain Restraint Kit (for use on fryers w/casters) |

8.4 Component Box Assemblies/Associated Component Parts

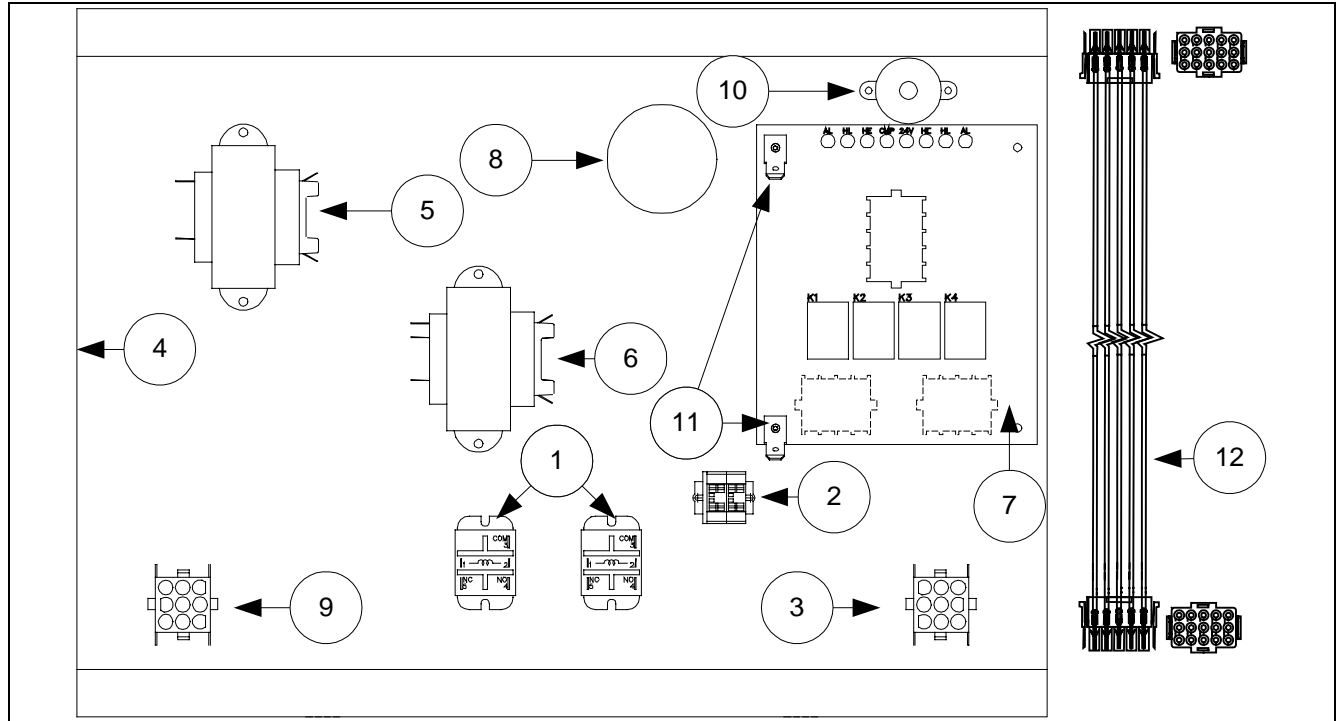

| ITEM | PART # | COMPONENT |
|------|------------|---|
| 1 | 807-1683 | Relay, Burnoff (McDonald's CE Models Only) |
| 2 | 810-1164 | Terminal Block Wire Assembly |
| 3 | 806-6863SP | Wire Assembly, Burnoff, Full-Vat (McDonald's CE only) |
| 3 | 806-6864SP | Wire Assembly, Burnoff, Dual-Vat (McDonald's CE only) |
| 4 | 806-8244 | Component Box/Stud Assembly |
| 5 | 807-2191 | 12 VAC Transformer, 208-240 V |
| 5 | 807-2192 | 12 VAC Transformer, 100-120V |
| 6 | 807-2180 | 24 VAC Transformer, 208-240 V |
| 6 | 807-2181 | 24VAC Transformer, 100-120V |
| 7 | 806-6336 | Interface Board |
| 8 | 807-1084 | Bushing |
| 9 | 806-6854SP | Wiring Assembly, Transformer |
| 10 | 806-7179SP | Sound Device |
| 11 | 826-1337 | Terminal Tab (Qty: 5) |
| 12 | 806-2071 | Cable Assembly, Computer/Interface Board |

8.5 Control Panel Assemblies/Top Caps/Door Assemblies/Related Components

8.5.1 Control Panel Assemblies and Top Caps

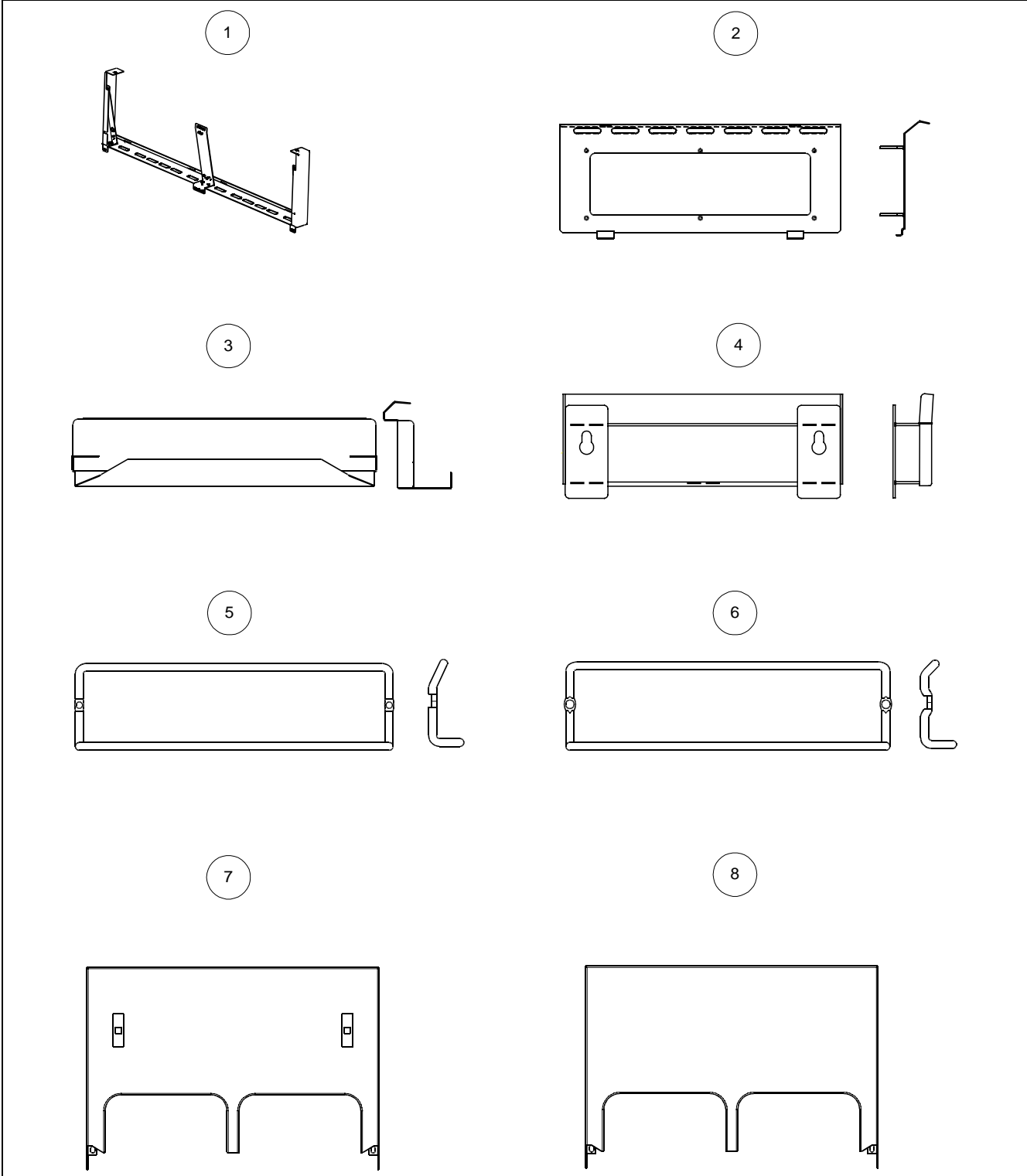

| ITEM | PART # | COMPONENT |
|------------------|------------|--|
| 1 | | Control Panel Assembly |
| | 806-9821SP | Center Brace, Control Panel (Double, Triple, Quad) |
| | 809-0396 | Screw, #6-32 x 3/8 Phillips Pan Head, Type F |
| | 900-2732 | Bracket, Control Panel Support |
| | 910-4808 | Frame, Control Panel Bottom, Single |
| | 910-7045 | Frame, Control Panel Bottom, Double |
| | 910-9256 | Frame, Control Panel Bottom, Triple |
| | 910-9419 | Frame, Control Panel Bottom, Quad |
| | 911-2730 | End, Control Panel (Left) |
| | 912-2730 | End, Control Panel (Right) |
| 2 | 823-2307 | Control Panel, with Slot |
| 3 | 824-0577 | Top Cap, Single Fryer |
| * | 824-0575 | Top Cap, Two-Fryer Battery |
| * | 824-0576 | Top Cap, Three-Fryer Battery |
| * | 824-0578 | Top Cap, Four-Fryer Battery |
| 4 | 823-1618 | Basket Hanger, McDonald's |
| 5 | 810-1401 | Basket Hanger, Wire |
| 6 | 810-1403 | Basket Hanger, Wire-Offset |
| 7 | 824-0532 | Housing, MAC114 Tilt w/o cap/splash |
| * | 824-0534 | Housing, MAC214 Tilt w/o cap/splash |
| * | 824-0535 | Housing, MAC314 Tilt w/o cap/splash |
| * | 824-0536 | Housing, MAC414 Tilt w/o cap/splash |
| * | 910-7443 | Top Connecting Strip (for fryers w/o cap/splash) |
| * | 910-2420 | Strip, MAC114 Electric Hood (for fryers w/o cap/splash) |
| * | 910-2439 | Strip, MAC 414 Electric Hood (for fryers w/o cap/splash) |
| * | 910-2440 | Strip, MAC 314 Electric Hood (for fryers w/o cap/splash) |
| * | 910-2441 | Strip, MAC 214 Electric Hood (for fryers w/o cap/splash) |
| 8 | 824-0645 | Housing, MAC114 HE Tilt with cap/splash |
| * | 824-0647 | Housing, MAC214 HE Tilt with cap/splash |
| * | 824-0648 | Housing, MAC314 HE Tilt with cap/splash |
| * | 824-0646 | Housing, MAC414 HE Tilt with cap/splash |
| *Not Illustrated | | |

8.5.1 Door Assembly Components

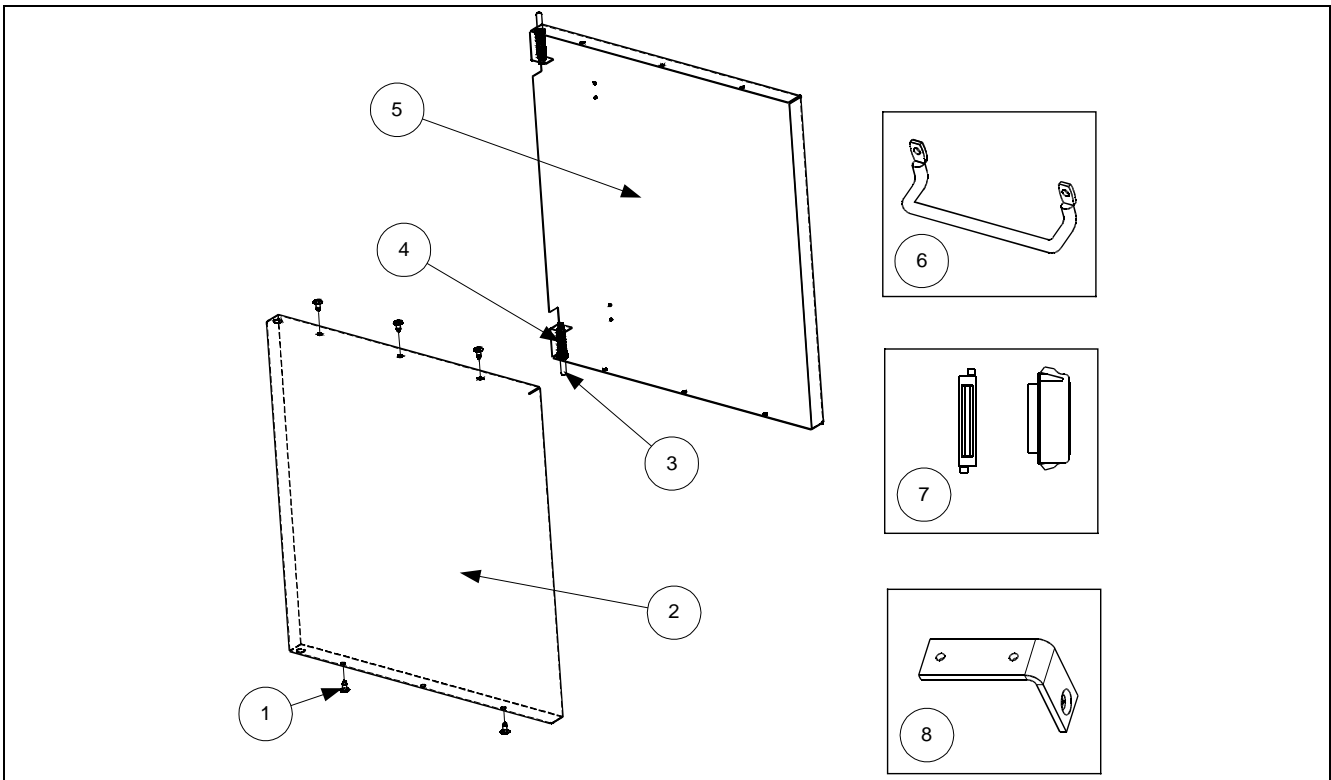

| ITEM | PART # | COMPONENT |
|-------------------|------------|--|
| | 806-6545SP | Door Assembly, Universal |
| 1 | 809-0266 | Screw, #10- 1/2-inch |
| 2 | 824-0137SP | Panel, Door |
| 3 | 806-4487SP | Door Pin Assembly |
| * | 809-0193 | Washer, Flat 1/4-Inch Nylon (Door Pin Bushing) |
| 4 | 826-1343 | Spring, Door Hinge (Qty: 10) |
| 5 | 900-2485 | Liner, Door |
| 6 | 810-1422 | Handle, Wireform, Door |
| 7 | 810-1105 | Magnet, Door |
| 8 | 810-1508 | Hinge, Universal Door |
| * Not Illustrated | | |

8.6 Controller Assemblies

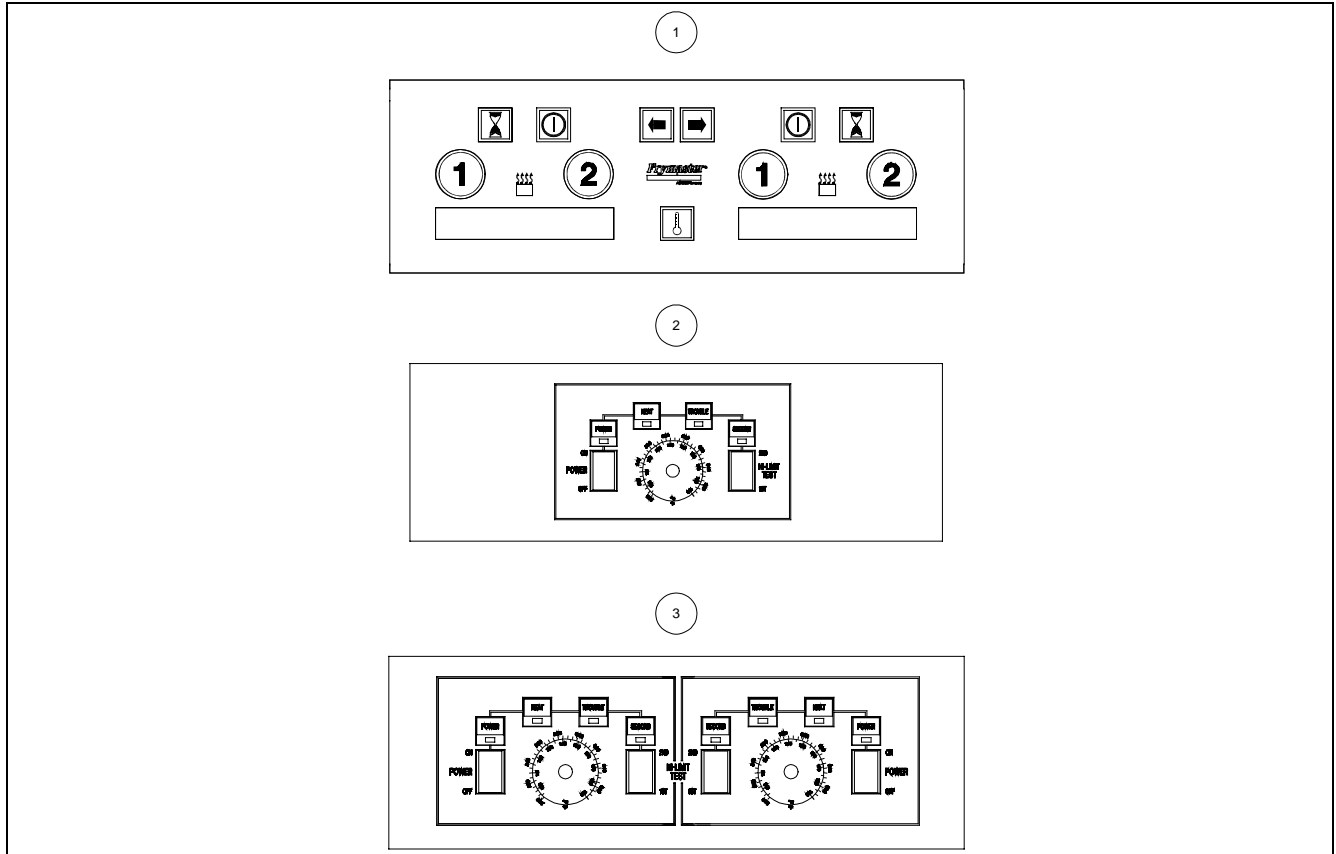

| ITEM | PART # | COMPONENT |
|-------------------|----------|------------------------------------|
| 1 | 806-7990 | Computer, M100B |
| * | 806-8000 | Computer, M100B Standard, Electric |
| * | 806-8036 | Computer, M100B, International |
| * | 806-8103 | Computer, M100B, CE Electric |
| 2 | 806-7436 | Controller, Full-Vat, MH/BIH14 |
| 3 | 806-7437 | Controller, Dual-Vat, MH/BIH14 |
| * Not Illustrated | | |

8.7 Drain System Components

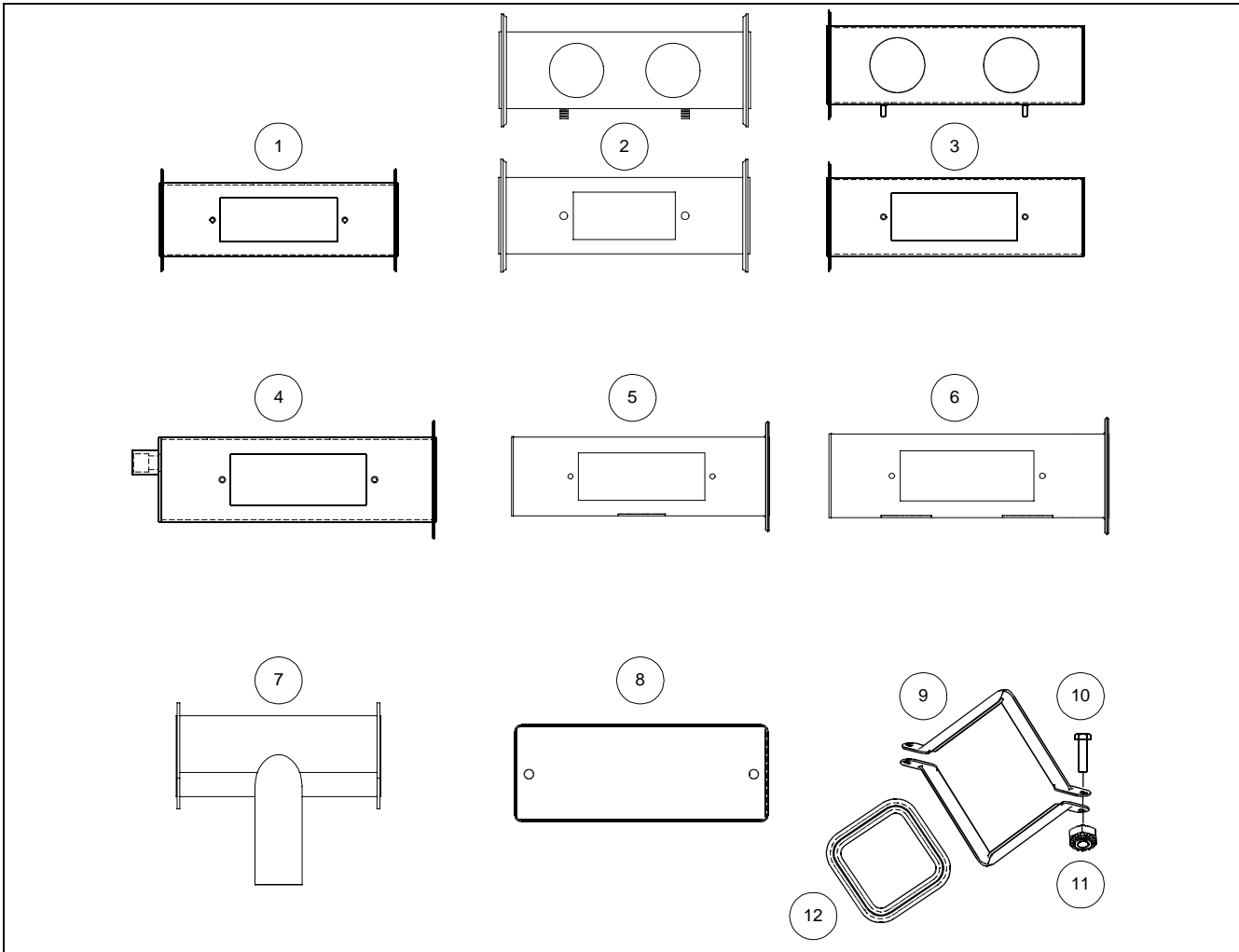

| ITEM | PART # | COMPONENT |
|------|----------|--|
| 1 | 823-0718 | Drain Tube, Left End, 2.5 x 8.0" |
| 2 | 823-0725 | Drain Tube, Left End, Dual-Vat, 2.5 x 8.0" |
| 3 | 823-1551 | Drain Tube, Right End, Dual Vat |
| 4 | 823-2636 | Drain Tube, Left End, Dual-Vat |
| * | 823-2637 | Drain Tube, Left End, Full-Vat |
| 5 | 823-1549 | Drain Tube, Right End, Full-Vat |
| 6 | 823-1543 | Drain Tube, Right End, Dual-Vat |
| 7 | 823-2336 | Drain, FootPrint |
| 8 | 826-1348 | Cover, Drain Cleanout (Qty: 5) |
| 9 | 810-0396 | Clamp, 2.5" Drain, Filter Magic (Two Required Per Union) |
| 10 | 826-1375 | Screw, 10-32 x 3/4 Hex Trim HD SS (Qty: 5) |
| 11 | 8261376 | Nut, 10-32 Hex (Qty: 10) |
| 12 | 816-0032 | Gasket, Square Drain |

* Not Illustrated

8.8 Electrical Components: Contactors, Elements and Related Components

8.8.1 Contactors

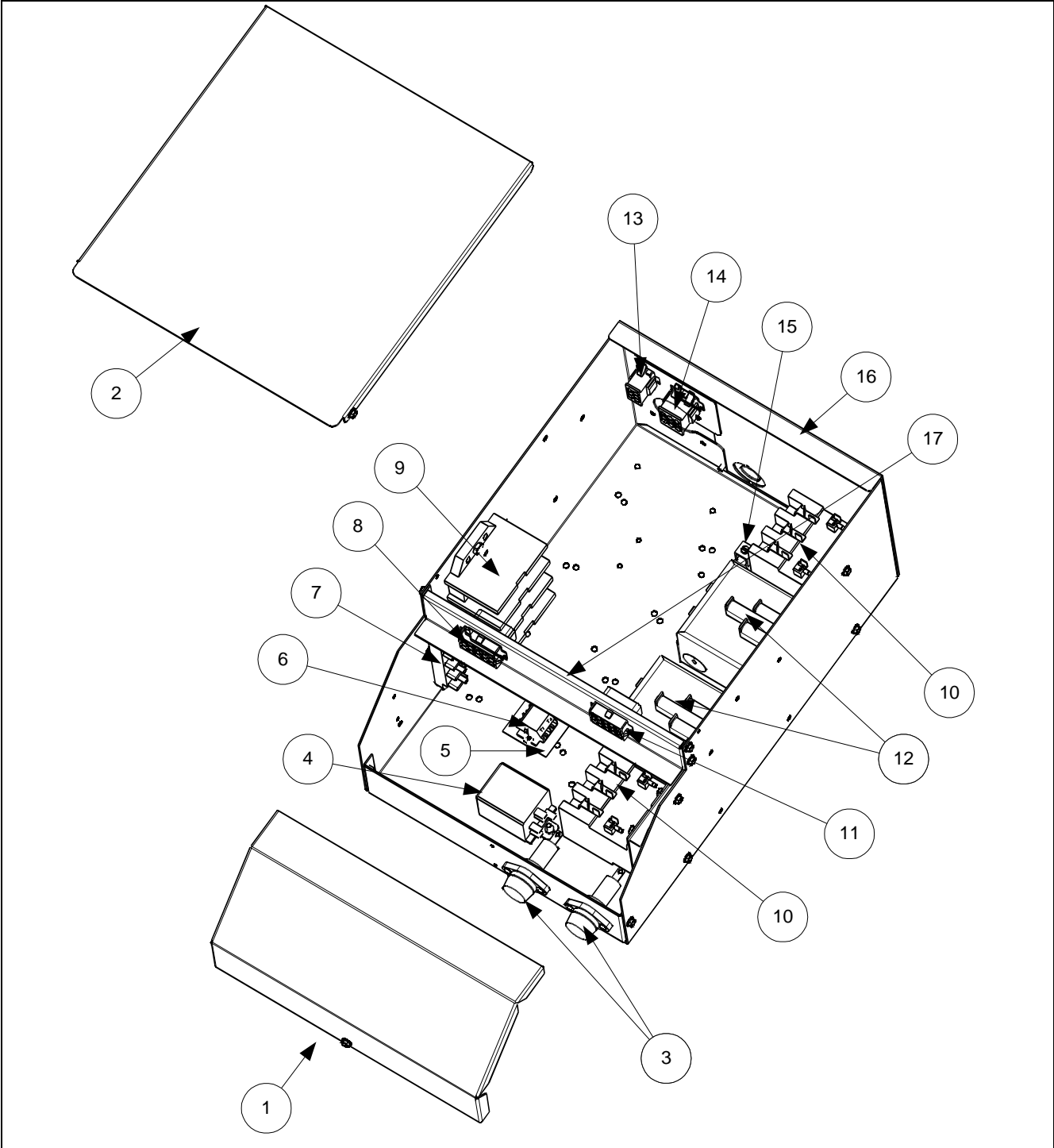

| ITEM | PART # | COMPONENT |
|-------------------|---------------|--|
| 1 | 900-5445 | Front Cover, Contactor Box |
| 2 | 900-5446 | Top Cover, Contactor Box |
| 3 | 807-0922 | Holder, Buss Fuse |
| * | 807-2278 | Fuse, 20 Amp |
| 4 | 807-2515 | Relay, 120V SPDT, 10A |
| 5 | 816-0217 | Paper, Insulating Terminal Block (CE) |
| 6 | 810-1164 | Terminal Block |
| 7 | 807-1973 | Terminal Post |
| 8 | | C1 Wiring Assembly |
| | 806-7664SP | McDonald's Domestic, Full-vat |
| | 806-7669SP | McDonald's Domestic, Dual-vat |
| | 806-8095SP | McDonald's CSA, Full-vat |
| | 806-8096SP | McDonald's CSA, Dual-vat |
| | 806-7197SP | McDonald's Export, Full-vat |
| | 806-8017SP | McDonald's Export, Dual-vat |
| 9 | 807-2464 | Power Block, Delta |
| 10 | 810-1202 | Contactor, 3-Pole 600V 40 Amp |
| 11 | | C2 Wiring Assembly |
| | 806-8269 | McDonald's Domestic, Full- and Dual-vat |
| | 806-7666SP | McDonald's Export, Full- and Dual-vat |
| | 806-8094 | McDonald's CSA, Full- and Dual-vat |
| 12 | 807-1071 | Contactor, Mercury 24 VAC 30 Amp |
| 13 | 806-7183SP | Wire Assembly, Left, Dual-vat |
| * | 806-7186SP | Wire Assembly, Left, Full-vat |
| 14 | 806-7185SP | Wire Assembly, Right, Full- and Dual-vat |
| 15 | 807-0070 | Terminal, Ground Lug |
| 16 | 900-5447 | Back Cover, Contactor Box |
| 17 | 900-5782 | Bracket, Connector-Common Electric |
| * Not Illustrated | | |

8.8.2 Elements and Related Components

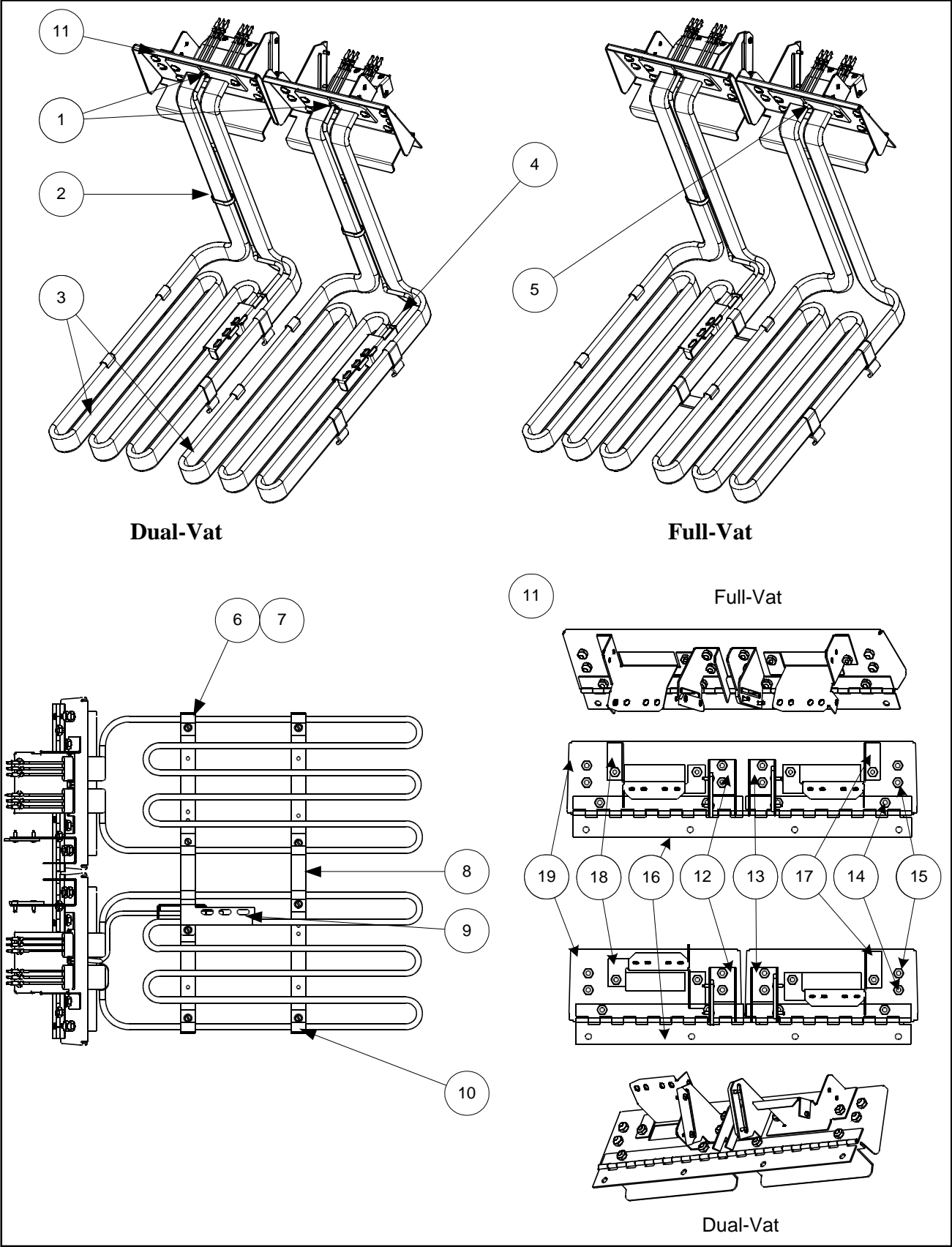

| ITEM | PART # | COMPONENT |
|-------------------|---------------|---|
| 1 | 826-1339 | Bushing, .375 Split (Qty: 10) |
| 2 | 809-0567 | Ty-Wrap, Metal |
| 3 | | Heating Element |
| | 807-2639 | Heating Element, 208V 7 kW |
| | 807-2641 | Heating Element, 220V 8.5 kW |
| | 807-2642 | Heating Element, 230V 7 kW |
| | 807-2643 | Heating Element, 230V 8.5 kW |
| | 807-2644 | Heating Element, 240V 7 kW |
| | 807-2645 | Heating Element, 240V 8.5 kW |
| | 807-2651 | Heating Element, 480V 7 kW |
| | 806-8474SP | Heating Element Assembly, 240V 14 kW Full-Vat |
| | 806-8520SP | Heating Element Assembly, 230V 15.6 kW Full-Vat |
| | 806-8523SP | Heating Element Assembly, 230V 17 kW Dual-Vat |
| 4 | 807-2478 | Temperature Probe |
| 5 | 816-0480 | Dome Plug, .375 OD. (Full-Vat Only) |
| 6 | 809-0518 | Screw #8 32 x 3/8-inch |
| 7 | 910-2042 | Clamp, Element |
| 8 | 910-3681 | Element Support, Full-Vat |
| * | 910-5214 | Element Support, Dual-Vat |
| 9 | 910-5022 | Bracket, Temperature Probe |
| 10 | 910-5213 | Clamp, H14/H17 Element |
| 11 | 106-0003SP | Tilt Plate Assembly, Full-vat |
| * | 106-0004SP | Tilt Plate Assembly, Dual-vat |
| | | Tilt Plate Assembly, Individual Components |
| 12 | 806-8285SP | Spring Slot Bracket Assembly, Right |
| 13 | 806-8286SP | Spring Slot Bracket Assembly, Left |
| * | 810-0297 | Spring, Element |
| 14 | 826-1330 | Screw, 10-32 x 3/8 (Qty: 25) |
| 15 | 826-1376 | Nut, 10-32 (Qty: 10) |
| 16 | 810-0035 | Hinge, Stainless Steel Split—14-Inch |
| 17 | 901-8509 | Bracket, Element Support, Left |
| 18 | 902-8509 | Bracket, Element Support, Right |
| 19 | 910-9640 | Plate, Tilt, Full-Vat (1 Required) |
| 19 | 910-9641 | Plate, Tilt, Dual-Vat (2 Required) |
| * | 826-1061 | Tilt Switch, Mercury Non-CE (Full-Vat requires one switch and Dual-Vat requires two.) |
| * | 826-2228 | Tilt Switch, CE (Full-Vat requires one switch and Dual-Vat requires two.) |
| * Not Illustrated | | |

8.8.3 Hood Relay Box, Power Cords and Hood Cords

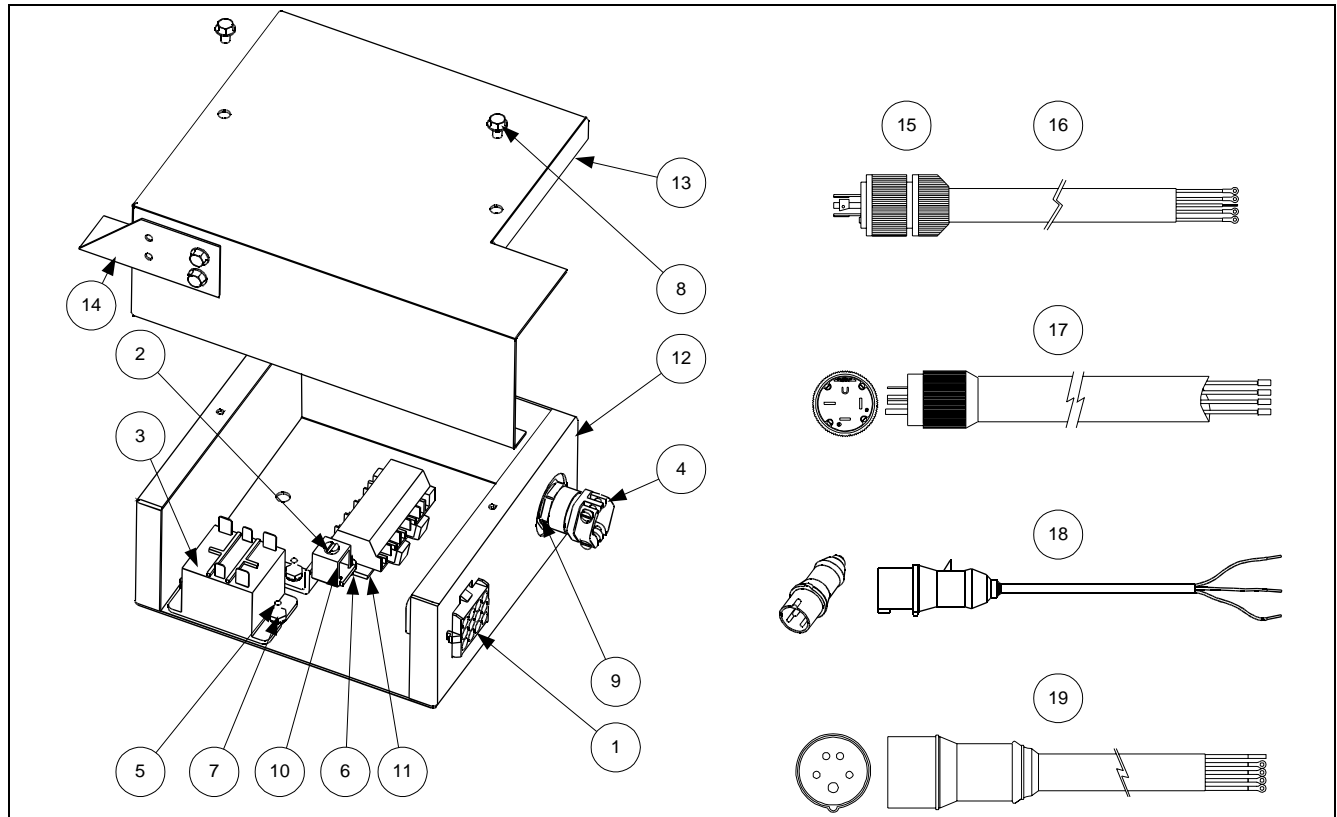

| ITEM | PART # | COMPONENT |
|------|------------|--|
| 1 | 806-9381SP | Wire Assembly, CE Mac |
| * | 806-9389SP | Wire Assembly, Non-CE Mac |
| 2 | 807-0070 | Terminal, Ground Lug |
| 3 | 807-1683 | Hood Relay, 12VDC |
| 4 | 807-1694 | Strain Relief, HE |
| 5 | 826-1363 | Screw, #8- 32 x 1/2 (Qty: 25) |
| 6 | 809-0238 | Nut, 4-40 Hex |
| 7 | 809-0247 | Nut, 8-32 Hex |
| 8 | 809-0359 | Screw, #8- 32 x 1/4 Hex-slotted |
| 9 | 809-0492 | Nut, Lock |
| 10 | 809-0656 | Screw, 4-40 x 3/8 Round-slotted |
| 11 | 810-1163 | Terminal Block, Screwless |
| * | 807-1973 | Terminal, Post (Non-CE) |
| 12 | 900-8024 | Box, Control Cord, CE Mac |
| 13 | 900-8025 | Cover, Control Cord Box |
| 14 | 901-1530 | Bracket, Attaching, Control Panel |
| 15 | 807-1558 | Plug, 4 Pole 5 Wire 20A |
| 16 | 806-5229 | Cordset, 120V 5 Wire (Plug not included) |
| 17 | 807-2392 | Cordset, Power, 3 Phase, 4-Wire w/Plug |
| 18 | 807-1696 | Cordset, Power, Europe, 3-Wire w/Plug |
| 19 | 806-8164SP | Cordset, Power, Full-vat Export |

8.9 Filter Base/Pan Assemblies

8.9.1 Filter Base Assemblies

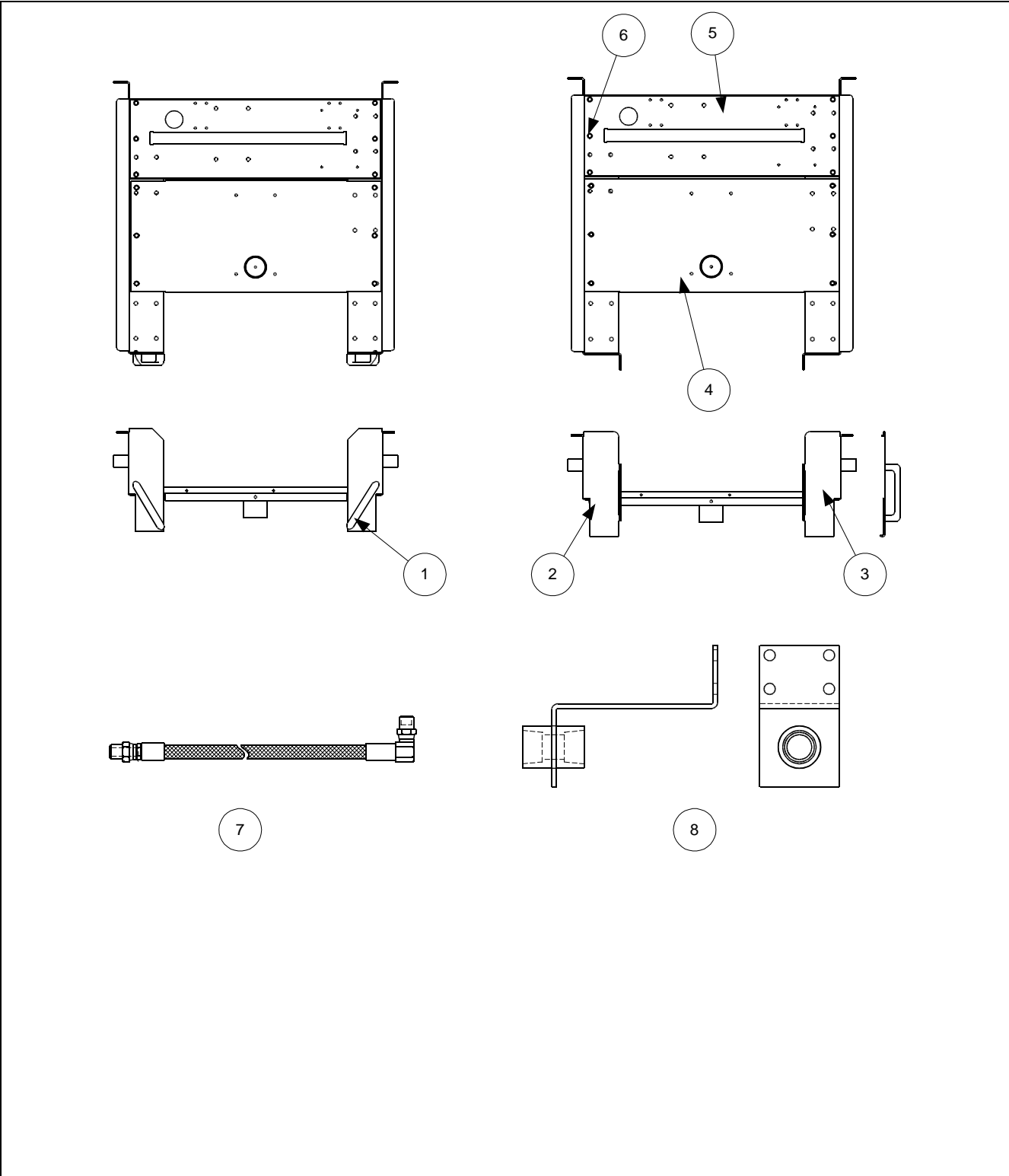

| ITEM | PART # | COMPONENT |
|--|------------|---|
| | 806-8648SP | Filter Base Assembly, FootPrint III |
| 1 | 810-0180 | Handle, Filter Base Assembly |
| * | 826-1360 | Screw, #10-24 x 5/16 [Qty: 25 (to attach P/N 810-0180)] |
| 2 | 901-8542 | Filter Base, Left Side |
| 3 | 902-8542 | Filter Base, Right Side |
| 4 | 823-2289 | Filter Pan Support |
| 5 | 900-5396 | Motor Support |
| 6 | 826-1374 | Screw, #10-1/2 Hex Head (Qty: 25) |
| * | 900-5477 | Cover, Motor (August 1997 and later) |
| * | 824-0558 | Cover, Motor (Prior to August 1997) |
| * | 900-1949 | Standoff, Filter Wiring Box |
| 7 | 810-1423 | Hose, Oil Return |
| 8 | 823-2638 | Bracket, Oil Return Hose |
| <p>NOTE: P/N 810-0180 (Pull Handle) is available as a replacement for damaged handles on base assemblies manufactured from 8/97 to 8/99, If damaged filter bases need replacement, they must be replaced with P/N 901-8542 and 902-8542, in which includes handles. Filter bases with replaceable handles are no longer available.</p> | | |
| <p>*Not Illustrated</p> | | |

8.9.2 Filter Pan Assemblies

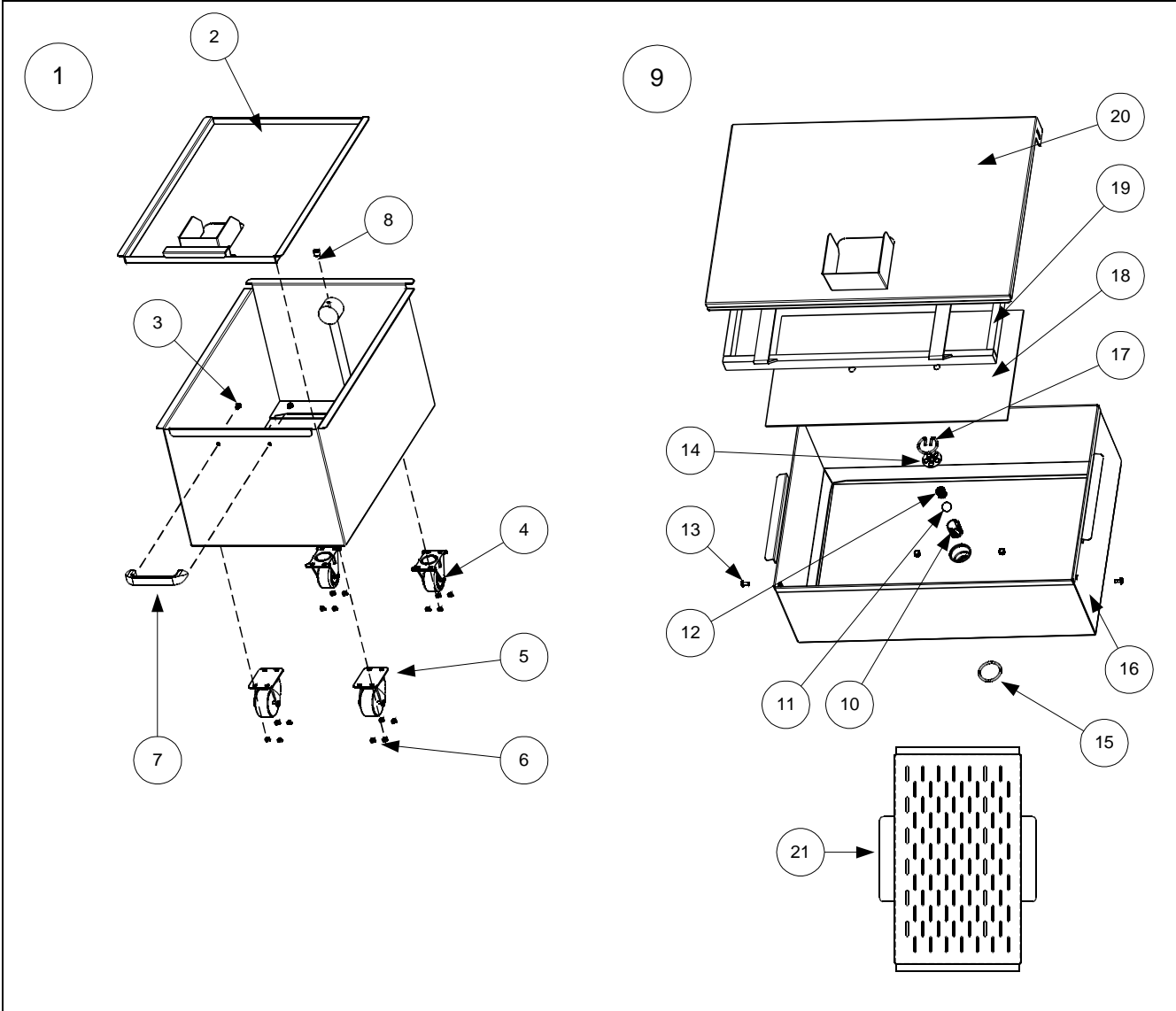

| ITEM | PART # | COMPONENT |
|------------------|---------------|---------------------------------------|
| 1 | 806-9546SP | Filter Pan Assembly, Single FootPrint |
| 2 | 806-9547SP | Cover Assembly, Filter Pan |
| * | 809-0045 | Nut, 10-32 |
| * | 809-0117 | Screw, 10-32 x 3/8 SS |
| * | 809-0185 | Washer, Flat #10 |
| * | 910-1816 | Handle, Filter Pan, Single FootPrint |
| 3 | 826-1360 | Screw, 10-24 x 5/16 (Qty: 25) |
| 4 | 810-0005 | Caster, Rigid |
| 5 | 810-0006 | Caster, Swivel |
| 6 | 826-1376 | Nut, 10-32 (Qty: 10) |
| 7 | 810-0180 | Handle, Door |
| 8 | 813-0411 | Plug, Pipe-1/8 Internal Hex |
| 9 | 806-6423SP | Filter Pan Assembly, FootPrint III |
| 10 | 810-1388 | Tube, Check Valve |
| 11 | 810-0948 | Ball, Check Valve |
| 12 | 810-0946 | Spring, Check Valve |
| 13 | 809-0422 | Screw, Shoulder 10-32 x 7/16 |
| 14 | 900-5448 | Strain Plate, Check Valve |
| 15 | 816-0181 | O-Ring, Check Valve |
| 16 | 823-2234SP | Filter Pan |
| 17 | 810-1387 | Retainer, Check Valve |
| 18 | 900-8818 | Screen |
| 19 | 810-1405 | Hold-down Ring |
| 20 | 823-2027 | Cover, Filter Pan |
| 21 | 824-0430 | Crumb Screen |
| *Not Illustrated | | |

8.10 Filter Pump and Motor Assemblies

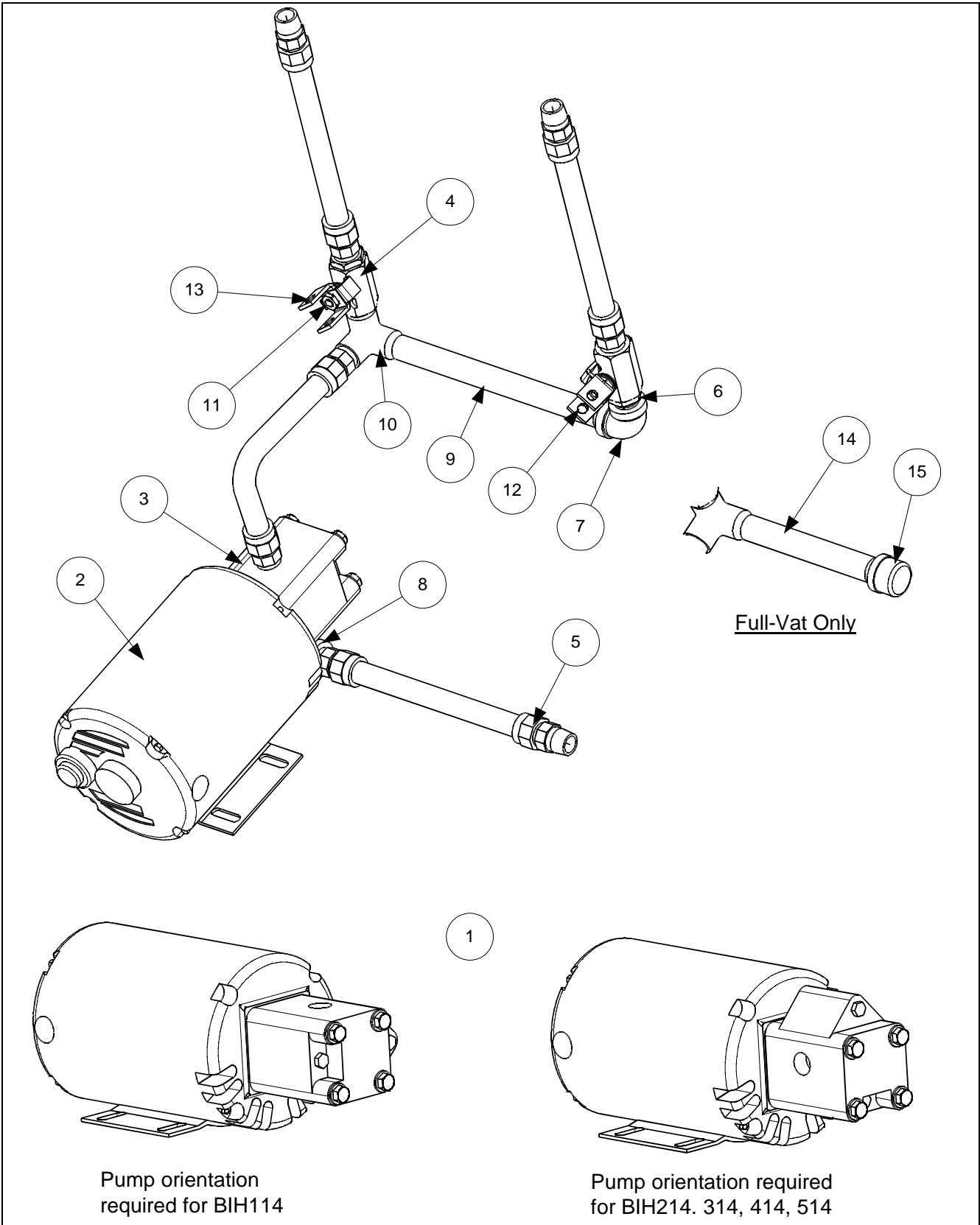

| ITEM | PART # | COMPONENT |
|-------------------|---------------|--|
| 1 | 806-6118SP | Pump and Motor Assembly, 250V 50/60 Hz |
| 2 | 826-1269 | Motor and Gasket Kit, 230V 50/60 Hz |
| * | 826-1266 | Motor and Gasket Kit, 208V 50/60 Hz |
| 3 | 807-1995 | Pump, Viking 4 GPM |
| * | 809-0514 | Cap Screw, 5/16-18 Hex Head |
| * | 809-0194 | Washer, Flat 5/16-inch |
| * | 816-0093 | Gasket, Pump/Motor |
| 4 | 810-0278 | Gemini Valve without Handle |
| 5 | 810-1067 | Flex Line, Oil Return, 11-inch |
| 6 | 813-0022 | Nipple, 1/2-inch x Close (Dual-Vat Configuration) |
| 7 | 813-0062 | Elbow, 1/2-inch 90 Degree (Dual-Vat Configuration) |
| 8 | 813-0165 | Elbow, 1/2 x 1/2-inch 90 Degree |
| 9 | 813-0253 | Nipple, 1/2 x 10-inch (Dual-Vat Configuration) |
| 10 | 813-0331 | Elbow, 1/2-inch, With Side Outlet |
| 11 | 900-2935 | Nut, Retainer; Oil Return Valve |
| 12 | 901-2772 | Handle, Valve, Rearflush Left (Dual-Vat Configuration) |
| 13 | 902-2772 | Handle, Valve, Rearflush Right |
| 14 | 813-0098 | Nipple, 1/2 x 6.5-inch |
| 15 | 813-0469 | Cap, Pipe 1/2-inch |
| * Not Illustrated | | |

8.11 Filtration Systems: Oil Return Plumbing and Linkage Assemblies

8.11.1 Oil Return Plumbing Assemblies and Components

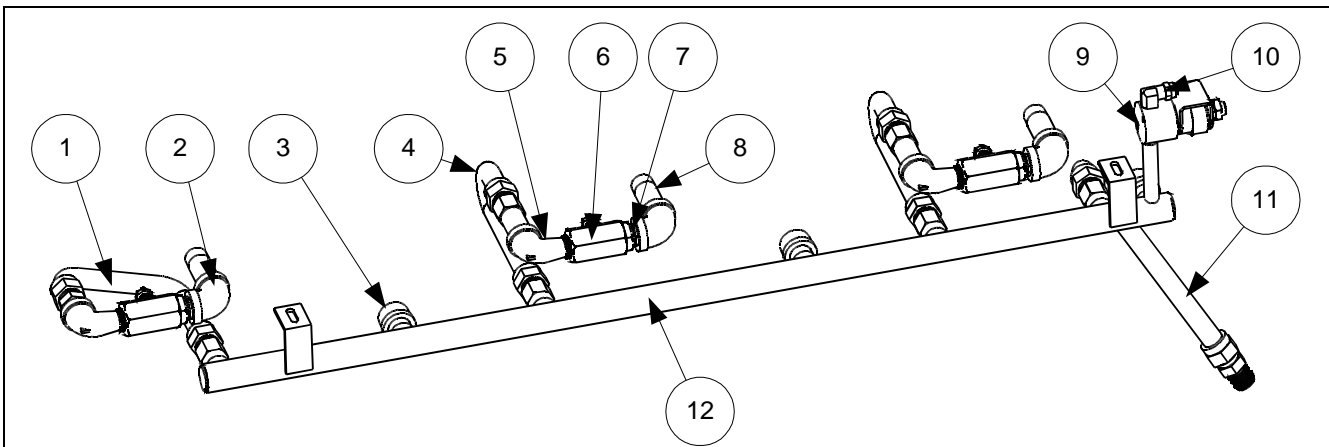

Manifold assembly for all H214, 314 and 414 fryers manufactured after 9/99.
Multiple-battery fryers of five or more require a special one-piece manifold

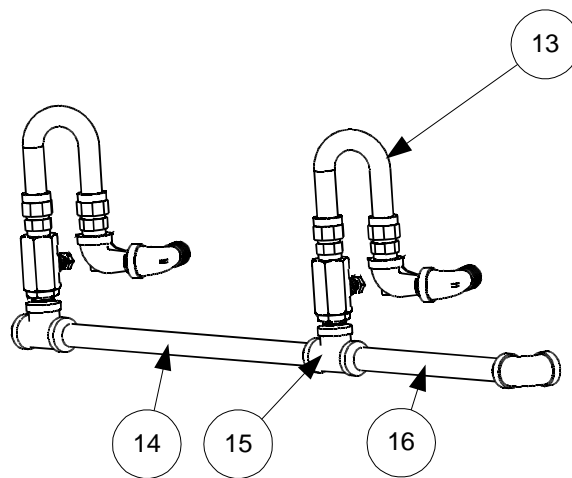

Manifold components for all H214, 314, 414 and 514 fryers
manufactured before 9/99.

| ITEM | PART # | COMPONENT |
|-------------------|---------------|---|
| 1 | 106-0002SP | Flex Line Assembly, With Male/Female Ends |
| 2 | 813-0062 | Elbow, ½-inch 90° |
| 3 | 813-0469 | Cap, Pipe ½-inch |
| 4 | 106-0054SP | Flex Line Assembly, With Female Ends |
| 5 | 813-0165 | Elbow, Street, ½ x ½-inch 90° |
| 6 | 810-0278 | Gemini Valve, Without Handle |
| 7 | 813-0022 | Nipple, ½-inch Close NPT |
| 8 | 813-0265 | Nipple, ½ x 2.5-inch NPT |
| 9 | 807-2484 | Vent Valve, Solenoid ¼-inch NPT |
| * | 812-1322SP | Vent Tube, Teflon 3/8-inch OD |
| 10 | 810-1372 | Fitting, 90°, ¼-inch NPT: 3/8 Tube |
| 11 | 806-9439SP | Flex Line Assembly, 14-inch with Male/Female Ends |
| 12 | 810-1517 | Manifold, Oil Return, RF H314/17/22 |
| * | 810-1516 | Manifold, Oil Return, RF H214/17/22 |
| * | 810-1518 | Manifold, Oil Return, RF H414/17/22 |
| 13 | 810-1067 | Flex Line, Oil Return, 11-inch |
| 14 | 813-0509 | Nipple, ½ x 14.5-inch NPT |
| 15 | 813-0003 | Tee, ½ x ½ x ½-inch |
| 16 | 813-0275 | Nipple, ½ x 9-inch NPT |
| * | 813-0093 | Nipple, ½ x 4-inch NPT |
| * Not Illustrated | | |

8.11.2 Oil Return Linkage Assemblies and Components

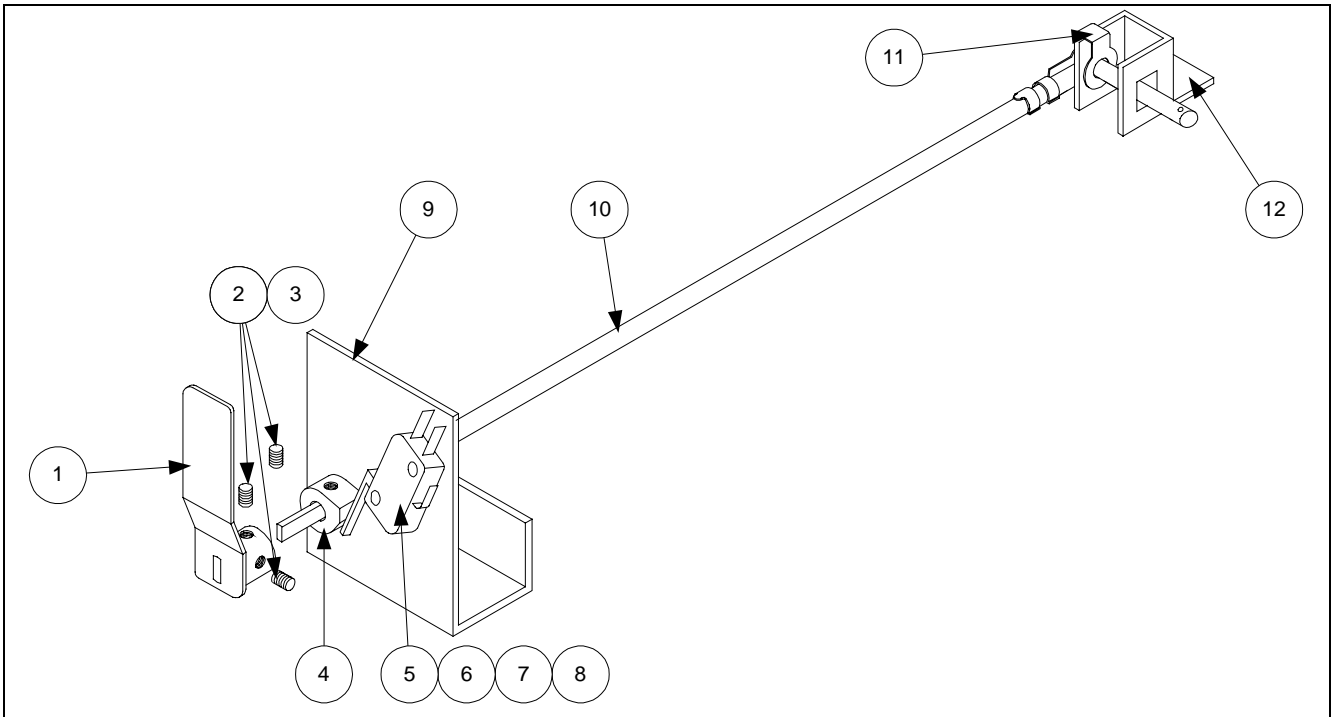

| ITEM | PART # | COMPONENT |
|------|----------|---|
| 1 | 823-2337 | Handle, Oil Return, Left |
| * | 823-2338 | Handle, Oil Return, Right |
| 2 | 826-1377 | Screw, Set 10-32 x 1/4 (Qty: 25) |
| 3 | 815-0789 | Loctite® Threadlocker 242 |
| 4 | 810-1186 | Cam, Microswitch |
| 5 | 807-2103 | Microswitch |
| 6 | 816-0220 | Insulation, Microswitch/Bracket |
| 7 | 826-1359 | Screw, 4-40 x 3/4-inch (Qty: 25) |
| 8 | 826-1366 | Nut, 4-40 Hex with External Tooth (Qty: 25) |
| 9 | 900-2571 | Bracket, Microswitch |
| 10 | 810-1180 | Shaft, Rotating Arm |
| 11 | 809-0601 | Clip, Clevis 5/16-inch |
| 12 | 901-2772 | Handle, Valve, Rear Flush, Left |
| 12 | 902-2772 | Handle, Valve, Rear Flush, Right |

* Not Illustrated

8.12 Frypot Assemblies and Drain Valve Components

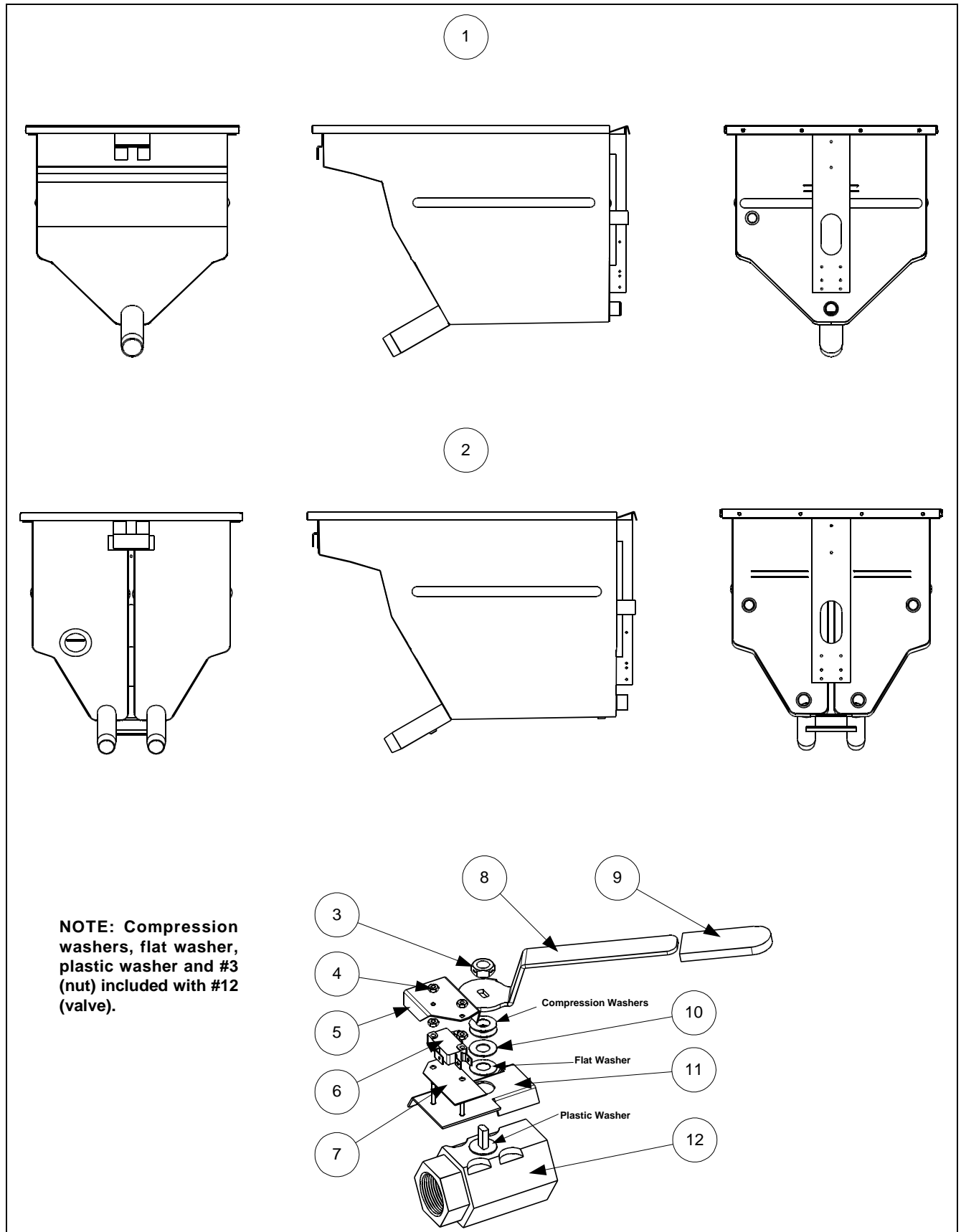

| ITEM | PART # | COMPONENT |
|-------------------|------------|--|
| 1 | 823-2454SP | Frypot Assembly, Full-Vat |
| 2 | 823-2460SP | Frypot Assembly, Dual-Vat |
| | | Drain Valve Assembly, Dual-Vat |
| 3 | 809-0539 | Nut, 3/8-16 2-Way Lock |
| 4 | 826-1366 | Nut, 4-40 Hex (Qty: 25) |
| 5 | 901-2348 | Cover, Safety Switch, Left DV |
| * | 902-2348 | Cover, Safety Switch, Right DV |
| 6 | 807-2104 | Microswitch |
| 7 | 816-0220 | Insulation, Microswitch/Bracket |
| 8 | 900-2607 | Drain Valve Handle, Left DV |
| * | 900-2608 | Drain Valve Handle, Right DV |
| 9 | 814-0047 | Sleeve, Valve Handle, Red with Logo |
| 10 | 810-1165 | Washer, Teflon |
| 11 | 806-8194 | Bracket, Microswitch, Left DV |
| * | 806-8195 | Bracket, Microswitch, Right DV |
| 12 | 810-1338 | Valve, 1 Inch Universal |
| * | 806-7434SP | Drain Valve Assembly, Full-Vat |
| | | Drain Valve Components, Full-Vat |
| 3 | 809-0540 | Nut, 2-Way Lock |
| 4 | 826-1366 | Nut, 4-40 Hex (Qty: 25) |
| 5 | 900-2841 | Cover, Safety Switch |
| 6 | 807-2103 | Microswitch |
| 7 | 816-0220 | Insulation, Microswitch/Bracket |
| 8 | 900-2609 | Drain Valve Handle |
| 9 | 814-0047 | Sleeve, Valve Handle, Red with Logo |
| 10 | | <i>Not used on Full-vat Drain Valve Assemblies</i> |
| 11 | 806-8137 | Bracket, Microswitch |
| 12 | 810-1020 | Valve, Gemini 1-1/4-inch |
| * Not Illustrated | | |

8.13 Thermostats and Related Components

| ITEM | PART # | COMPONENT |
|-------------------|----------|---|
| * | 806-8035 | High-Limit Thermostat (Dual-vat; Coded Red) |
| * | 806-7543 | High-Limit Thermostat (Full-vat; Coded Black) |
| * | 806-8132 | High-Limit Thermostat [All European Community (CE); Coded Yellow] |
| * Not Illustrated | | |



FRYMASTER
8700 LINE AVENUE, SHREVEPORT, LA 71106-6800

800-551-8633
318-865-1711

WWW.FRYMASTER.COM

EMAIL: FRYSERVICE@WELBILT.COM



Welbilt offers fully-integrated kitchen systems and our products are backed by KitchenCare® aftermarket parts and service. Welbilt's portfolio of award-winning brands includes Cleveland™, Convotharm®, Crem®, Delfield®, Frymaster®, Garland®, Kolpak®, Lincoln®, Merco®, Merrychef® and Multiplex®.

Bringing innovation to the table • welbilt.com

©2022 Welbilt Inc. except where explicitly stated otherwise. All rights reserved. Continuing product improvement may necessitate change of specifications without notice.

Part Number FRY_SP_8195625 09/2022