

# Pasta

# Magic<sup>™</sup> 17/8SMS / 17/8BC / 17/8C

# Pasta Cooker

## Installation, Operation and Maintenance Manual

This manual is updated as new information and models are released. Visit our website for the latest manual.

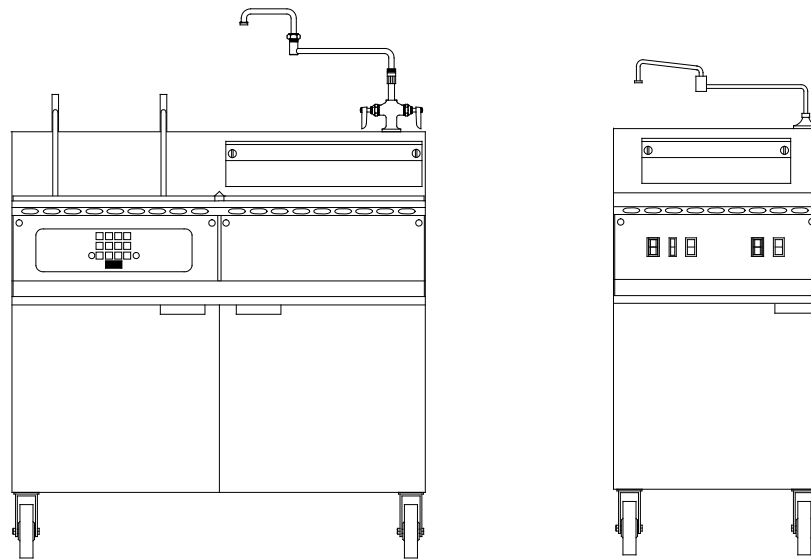

### FOR YOUR SAFETY

**Do Not Store or use gasoline or other flammable vapors and liquids in the vicinity of this or any other appliance.**

### CAUTION

**READ THE INSTRUCTIONS BEFORE USING THE FRYER.**

**Keep these instructions for future reference.**



8 1 9 6 8 8 9

Part Number: FRY\_IOM\_8196889 11/2022

Original Instructions



**WELBILT**<sup>®</sup>

**NOTICE**

IF, DURING THE WARRANTY PERIOD, THE CUSTOMER USES A PART FOR THIS FRYMASTER DEAN EQUIPMENT OTHER THAN AN **UNMODIFIED** NEW OR RECYCLED PART PURCHASED DIRECTLY FROM FRYMASTER DEAN OR ANY OF ITS FACTORY AUTHORIZED SERVICERS, AND/OR THE PART BEING USED IS MODIFIED FROM ITS ORIGINAL CONFIGURATION, THIS WARRANTY WILL BE VOID. FURTHER, FRYMASTER DEAN AND ITS AFFILIATES WILL NOT BE LIABLE FOR ANY CLAIMS, DAMAGES OR EXPENSES INCURRED BY THE CUSTOMER WHICH ARISE DIRECTLY OR INDIRECTLY, IN WHOLE OR IN PART, DUE TO THE INSTALLATION OF ANY MODIFIED PART AND/OR PART RECEIVED FROM AN UNAUTHORIZED SERVICER.

**NOTICE**

This appliance is intended for professional use only and is to be operated by qualified personnel only. A Frymaster Dean Authorized Servicer (FAS) or other qualified professional should perform installation, maintenance, and repairs. Installation, maintenance, or repairs by unqualified personnel may void the manufacturer's warranty. See Chapter 1 of this manual for definitions of qualified personnel.

**NOTICE**

This equipment must be installed in accordance with the appropriate national and local codes of the country and/or region in which the appliance is installed. See NATIONAL CODE REQUIREMENTS in Chapter 2 of this manual for specifics.

**NOTICE TO U.S. CUSTOMERS**

This equipment is to be installed in compliance with the basic plumbing code of the Building Officials and Code Administrators International, Inc. (BOCA) and the Food Service Sanitation Manual of the U.S. Food and Drug Administration.

** WARNING**

Improper installation, adjustment, maintenance or service, and unauthorized alterations or modifications can cause property damage, injury, or death. Read the installation, operating, and service instructions thoroughly before installing or servicing this equipment.

** DANGER**

**FOR YOUR SAFETY** do not store or use gasoline or other flammable liquids or vapors in the vicinity of this or any other appliance.

** DANGER**

This equipment is intended for indoor use only. Do not install or operate this equipment in outdoor areas

** DANGER**

Do not operate this equipment unless it has been properly installed and checked by qualified personnel.

** DANGER**

Do not operate this equipment unless all covers and access panels are in place and properly secured.

** DANGER**

When installed, this appliance must be electrically grounded in accordance with local codes, or in the absence of local codes, with the National Electrical Code, ANSI/NFPA 70, the Canadian Electrical Code, CSA C22.2, or the appropriate national code of the country in which installed.

**NOTICE TO OWNERS OF UNITS EQUIPPED WITH COMPUTERS**

**U.S.**

This device complies with Part 15 of the FCC rules. Operation is subject to the following two conditions: 1) This device may not cause harmful interference, and 2) This device must accept any interference received, including interference that may cause undesired operation. While this device is a verified Class A device, it has been shown to meet the Class B limits.

**CANADA**

This digital apparatus does not exceed the Class A or B limits for radio noise emissions as set out by the ICES-003 standard of the Canadian Department of Communications.

Cet appareil numérique n'émet pas de bruits radioélectriques dépassant les limites de classe A et B prescrites dans la norme NMB-003 édictée par le Ministre des Communications du Canada.

**NOTICE**

This appliance is intended to be used for commercial applications, for example in kitchens of restaurants, canteens, hospitals and in commercial enterprises such as bakeries, butcheries, etc., but not for continuous mass production of food.

**NOTICE**

Drawings and photos used in this manual are intended to illustrate operational, cleaning and technical procedures and may not conform to onsite management operational procedures.

** DANGER**

Adequate means must be provided to limit the movement of this appliance without depending on or transmitting stress to the electrical conduit. A restraint kit is provided with the cooker. If the restraint kit is missing contact your local KES.

** DANGER**

This cooker has a power cord (three-phase) for each cook pot. Prior to movement, testing, maintenance and any repair on your Frymaster cooker; disconnect ALL electrical power cords from the electrical power supply.

** WARNING**

This appliance is not intended for use by children under the age of 16 or persons with reduced physical, sensory or mental capabilities, or lack of experience and knowledge, unless they have been given supervision concerning use of the appliance by a person responsible for their safety. Children should be supervised to ensure that they do not play with this appliance.

** DANGER**

This appliance must be connected to a power supply having the same voltage and phase as specified on the rating plate located on the inside of the appliance door.

** WARNING **

Use caution and wear appropriate safety equipment to avoid contact with hot surfaces that may cause severe burns or injury.

** DANGER**

No structural material on the cooker should be altered or removed to accommodate placement of the cooker under a hood. Questions? Call the Frymaster Dean Service Hotline at 1-800-551-8633.

 **DANGER**

Prior to movement, testing, maintenance and any repair on your Frymaster equipment; disconnect ALL electrical power cords from the electrical power supply.

 **WARNING**

Do not use water jets to clean this equipment.

 **WARNING**

If the electrical power supply cord is damaged, it must be replaced by a Frymaster Factory Authorized Servicer or a similarly qualified person in order to avoid a hazard.

 **WARNING**

Operation, installation, and servicing of this product may expose you to chemicals/products including [Bisphenol A (BPA), glass wool or ceramic fibers, and crystalline silica], which is [are] known to the State of California to cause cancer, birth defects or other reproductive harm. For more information go to [www.P65Warnings.ca.gov](http://www.P65Warnings.ca.gov).

 **WARNING**

Do not leave the cooker unattended during use.

 **WARNING**

Opening the drain valve will lead to the outflow of the hot contents of the cooker that can cause injury.

# ELECTRIC COOKER MODELS 17SMS, 17BC, 17C

## TABLE OF CONTENTS

---

### **CHAPTER 1: General Information**

1.1	Parts Ordering and Service Information.....	1-1
1.2	Safety Information.....	1-1
1.3	Equipment Description.....	1-2
1.4	Installation, Operating, and Service Personnel.....	1-3
1.5	Definitions.....	1-3
1.6	Shipping Damage Claim Procedure.....	1-4

### **CHAPTER 2: Installation Instructions**

2.1	General Installation Requirements.....	2-1
2.2	Caster/Leg Installation.....	2-2
2.3	Pre-Connection Preparations.....	2-2
2.4	Connection to the Electrical Power Supply.....	2-3

### **CHAPTER 3: Operating Instructions**

3.1	Spaghetti Magic II Controller.....	3-1
3.2	Boiling Out the Cookpot.....	3-4

### **CHAPTER 4: Preventive Maintenance**

	Daily Preventive Maintenance.....	4-1
--	-----------------------------------	-----

### **CHAPTER 5: Operator Troubleshooting**

5.1	Introduction.....	5-1
5.2	Operator Troubleshooting Guide.....	5-2

# ELECTRIC COOKER MODELS 17/8SMS, 17/8BC, 17/8C

## CHAPTER 1: GENERAL INFORMATION

---

### 1.1 Parts Ordering and Service Information

In order to assist you as quickly as possible, the Frymaster Factory Authorized Servicer (FAS) or Service Department representative requires certain information about your equipment. Most of this information is printed on a data plate affixed to the inside of the door.

Parts orders may be placed directly with your local FAS or distributor.

When ordering parts, the following information is required:

Model Number: \_\_\_\_\_  
Serial Number: \_\_\_\_\_  
Voltage: \_\_\_\_\_  
Item Part Number: \_\_\_\_\_  
Quantity Needed: \_\_\_\_\_

A list of Factory Authorized Service agents can be found at [www.frymaster.com](http://www.frymaster.com). Service information can also be obtained by contacting your local FAS/Distributor. Information may also be obtained by calling the Frymaster Technical Service Department at 1-800-551-8633 or 1-318-865-1711. When requesting service, please have the following information ready:

Model Number: \_\_\_\_\_  
Serial Number: \_\_\_\_\_  
Voltage: \_\_\_\_\_

In addition to the model number, serial number, and voltage, please be prepared to describe the nature of the problem and have ready any other information that you think may be helpful in solving your problem.

**RETAIN AND STORE THIS MANUAL IN A SAFE PLACE FOR FUTURE USE.**

### 1.2 Safety Information

Before attempting to operate your unit, read the instructions in this manual thoroughly.

Throughout this manual, you will find safety notations enclosed in boxes similar to the ones illustrated below and on the following page.

 <b>CAUTION</b>
<b>CAUTION</b> boxes contain information about actions or conditions that <i>may cause or result in malfunction of your equipment.</i>

 **WARNING**

**WARNING** boxes contain information about actions or conditions that *may cause or result in damage to your equipment*, and which may cause your equipment to malfunction.

 **DANGER**

**DANGER** boxes contain information about actions or conditions that *may cause or result in injury to personnel*, and which may cause damage or malfunctioning of your equipment

### 1.3 Equipment Description

#### Model Comparison:

**17/8SMS:** Cooker with separate rinse tank, automatic timed basket lift.

**17/8BC:** Cooker with automatic timed basket lift.

**17/8C:** Cooker only.

### 1.4 Installation, Operating, and Service Personnel

Operating information for Frymaster equipment is intended for use by qualified and/or authorized personnel only, as defined in Section 1.5.

**All installation and service on Frymaster equipment must be performed by qualified, certified, licensed, and or/authorized installation or service personnel, as defined in Section 1.5.**

### 1.5 Definitions

#### **QUALIFIED AND/OR AUTHORIZED OPERATING PERSONNEL**

Qualified/authorized operating personnel are those who have carefully read the information in this manual and have familiarized themselves with the equipment functions, or who have had previous experience with the operation of the equipment covered in this manual.

#### **QUALIFIED INSTALLATION PERSONNEL**

Qualified installation personnel are individuals, or firms, corporations, or companies that, either in person or through a representative, are engaged in and are responsible for the installation of electrical appliances. Qualified personnel must be experienced in such work, be familiar with all electrical precautions involved, and have complied with all requirements of applicable national and local codes.

#### **QUALIFIED SERVICE PERSONNEL**

Qualified service personnel are those who are familiar with Frymaster equipment and who are authorized by Frymaster to perform service on Frymaster equipment. All authorized service personnel are required to maintain a complete set of service and parts manuals and to stock a prescribed minimum amount of Frymaster parts. *Failure to use qualified service personnel will void the Frymaster Warranty on your equipment.*

## **1.6 Shipping Damage Claim Procedure**

Your Frymaster equipment was carefully inspected and packed before leaving the factory. The transportation company assumes full responsibility for safe delivery upon acceptance of the equipment for transport.

### **What to do if your equipment arrives damaged:**

- 1. File a claim for damages immediately**, regardless of the extent of damages.
- 2. Inspect for and record all visible loss or damage** and ensure that this information is noted on the freight bill or express receipt and is signed by the person making the delivery.
- 3. Concealed loss or damage** that was unnoticed until the equipment was unpacked should be recorded and reported to the freight company or carrier **immediately** upon discovery. A concealed damage claim must be submitted within 15 days of the date of delivery. Ensure that the shipping container is retained for inspection.

**FRYMASTER DOES NOT ASSUME RESPONSIBILITY  
FOR DAMAGE OR LOSS INCURRED IN TRANSIT.**



# ELECTRIC COOKER MODELS 17/8SMS, 17/8BC, 17/8C

## CHAPTER 2: INSTALLATION INSTRUCTIONS

---

### 2.1 General Installation Requirements

**PROPER INSTALLATION IS ESSENTIAL FOR EFFICIENT, TROUBLE-FREE OPERATION OF YOUR COOKER. ANY UNAUTHORIZED ALTERATIONS MADE TO THIS EQUIPMENT WILL VOID THE FRYMASTER WARRANTY.**

Upon arrival, inspect the cooker carefully for visible or concealed damage. (See **Shipping Damage Claim Procedure** in Chapter 1.)

### NATIONAL CODE REQUIREMENTS

This equipment is to be installed in compliance with the Basic Plumbing Code of the Building Officials and Code Administrators International, Inc. (BOCA) and the Food Service Sanitation Manual of the U.S. Food and Drug Administration.

### ELECTRICAL GROUNDING REQUIREMENTS

All electrically operated appliances must be grounded in accordance with all applicable national and local codes. A wiring diagram is located on the inside of the equipment door. Refer to the rating plate on the inside of the door for proper voltages.

### FCC COMPLIANCE

The user is cautioned that any changes or modifications to Frymaster computers not expressly approved by the party responsible for compliance could void the user's authority to operate the equipment. Frymaster computers have been tested and found to comply with the limits for a Class A digital device, pursuant to Part 15 of the FCC rules. While these devices are verified as Class A devices, they have been shown to meet the Class B limits. These limits are designed to provide reasonable protection against harmful interference when the equipment is operated in a commercial environment. This equipment generates, uses, and can radiate radio frequency energy and, if not installed and used in accordance with the instruction manual, may cause harmful interference to radio communications. Operation of the equipment in a residential area is likely to cause harmful interference in which case the user will be required to correct the interference at his own expense.

If necessary, the user should consult the dealer or an experienced radio and television technician for additional suggestions.

The user may find the booklet "How to Identify and Resolve Radio-TV Interference Problems" helpful. It is prepared by the Federal Communications Commission and is available from the U.S. Government Printing Office, Washington, DC 20402, Stock No. 004-000-00345-4.

## 2.2 Caster/Leg Installation

Depending upon the specific configuration ordered, your unit might have been shipped without installed casters or legs. If casters or legs are installed, you may skip this section and proceed to Section 2.3, Pre-Connection Preparations.

**If your unit requires the installation of casters/legs, install them in accordance with the instructions included in your accessory package.**

## 2.3 Pre-Connection Preparations

After the unit has been positioned in the area where it will be used, ensure the following have been accomplished before connecting the unit to the electrical power source:

1. This equipment must be stabilized by installing restraining chains on units equipped with casters or anchor straps on units equipped with legs. Follow the instructions shipped with the casters/legs to properly install the chains or straps.
2. Level units equipped with legs by screwing the legs out approximately 1 inch, then adjusting them so that the unit is level.

For units equipped with casters, there are no built-in leveling devices. The floor where the unit is to be installed must be level.

3. Install the basket lift arms (on units so equipped) on the lift rods (located at the top rear of the cabinet) so that the basket lift rollers guides the lift arms.

**NOTE:** *Some adjustment of the rollers may be necessary for free movement of the basket lift arms.*

4. If so equipped, connect the water hose(s) to the fitting(s) at the rear of the unit and connect the unit to the water supply.

### CAUTION

Incoming water pressure for all units should be approximately 40 PSI (2.8kg/cm<sup>2</sup>).

### DANGER

The maximum allowable incoming water pressure for all units is 80 PSI (5.62 kg/cm<sup>2</sup>).  
The maximum allowable incoming water temperature for all units is 180°F (82°C).

### WARNING

To prevent back flushing, the connection piping should be installed with a vacuum breaker or means of providing an air gap 1" (2.54 cm) above the cookpot rim.

**NOTE:** *On units equipped with water hoses, the hoses come with a quick-disconnect coupling. The quick disconnect may be attached to the unit or to the water supply line, or it may be left off entirely, whichever you prefer. If the unit is to be moved frequently (for cleaning or preventive maintenance), Frymaster recommends installing flexible water lines. If the cooker is hard-plumbed then moved, the connections may loosen and eventually cause leaks. Whichever option is chosen, Teflon thread-seal tape, Loctite™ PST56765 or equivalent thread sealer must be used when installing the fittings.*

**NOTE:** Depending on specific model ordered, either hot or cold water, or both, may be connected to the unit. If available, connecting hot water will minimize the time required to bring the unit to a boil when filling with fresh water.

**NOTE:** In order for the water level sensors to work properly, a certain amount of mineral content is necessary in the water. For that reason, purified, deionized, or highly filtered water should not be used.

5. Connect the desired drain plumbing to the drain valve. **NOTE: Ensure drain plumbing is connected in accordance with local codes. Waste water from the water bath unit should not be discharged directly below the appliance. Rising steam can harm the cabinet and the electrical components.**

## 2.4 Connecting to the Electrical Supply

### DANGER

This unit must be connected to the voltage and phase specified on the rating and serial number plate located on the inside of the equipment door. To determine the appropriate wire size, refer to the **POWER REQUIREMENTS** chart at the bottom of this page.

1. If the unit is not equipped with an installed power cord, open the door and remove the contactor box cover. Position the unit to gain access to the rear and remove the lower back panel.
2. Insert an appropriately rated power cord into the rear of the contactor box and make connections in accordance with the applicable wiring diagram on the following page. Install a strain relief on the power cord and replace the lower back panel and contactor box cover.
3. Attach a plug that complies with national and/or applicable local codes to the free end of the electrical power cord and plug the unit into an appropriate outlet.

<b>POWER REQUIREMENTS</b>				
<b>Use copper wire ONLY, suitable for at least 170°F (75°C)</b>				
<b>17kW Cookers</b>				
<b>Volts</b>	<b>Phase</b>	<b>Watts</b>	<b>Amps (per leg)</b>	<b>Minimum Wire Size</b>
208	3P 60 Hz	8625	47	AWG 6 (4.1 mm)
240	3P 60 Hz	8625	41	AWG 6 (4.1 mm)
240/415	3P 4-wire, 50 Hz	8625	24	AWG 6 (4.1 mm)
<b>8kW Cookers</b>				
200	Single	7400	37	AWG 6 (4.1 mm)
208	Single	8000	39	AWG 6 (4.1 mm)
220	Single	7300	34	AWG 6 (4.1 mm)
230	Single	8000	35	AWG 6 (4.1 mm)
240	Single	8000	34	AWG 6 (4.1 mm)
200	3P – Delta	7400	22	AWG 8 (3.3 mm)
208	3P – Delta	8000	23	AWG 8 (3.3 mm)
220	3P – Delta	7300	20	AWG 8 (3.3 mm)
230	3P – Delta	8000	21	AWG 8 (3.3 mm)
240	3P – Delta	8000	20	AWG 8 (3.3 mm)
200	3P – Wye	7400	13	AWG 8 (3.3 mm)
220	3P – Wye	7300	12	AWG 8 (3.3 mm)
230	3P – Wye	7400	11	AWG 8 (3.3 mm)

# FIELD CONNECTION WIRING DIAGRAMS

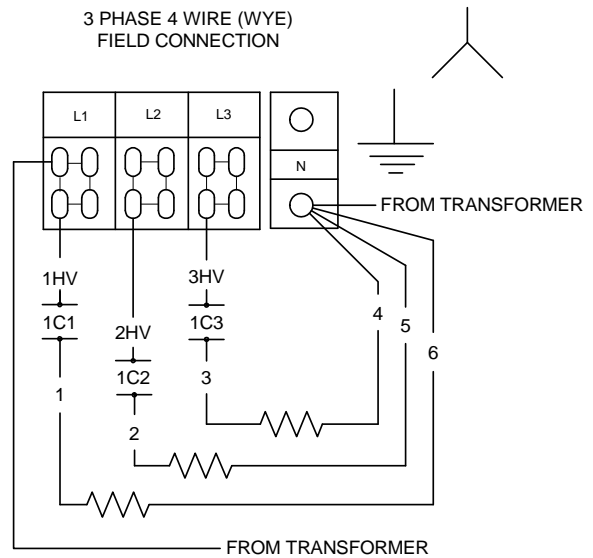
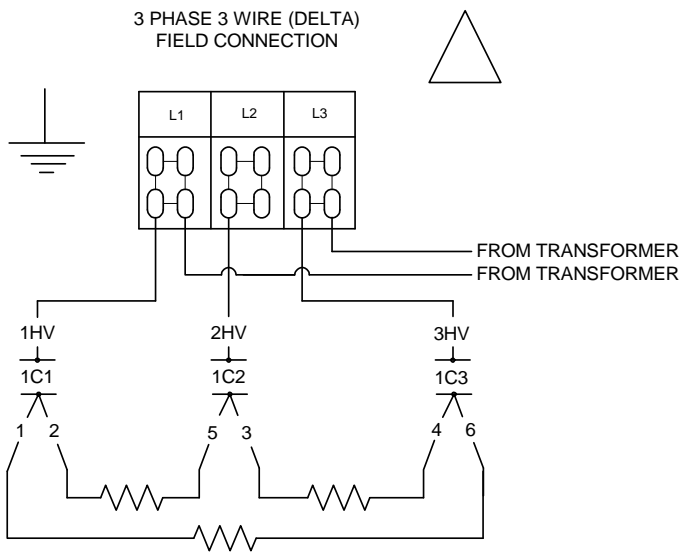
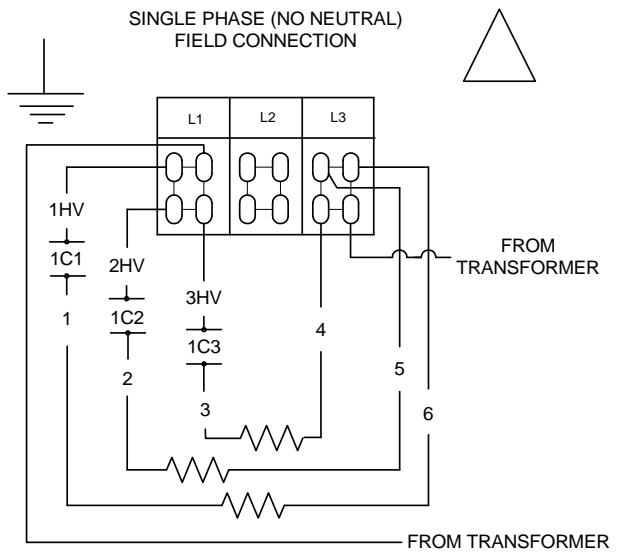
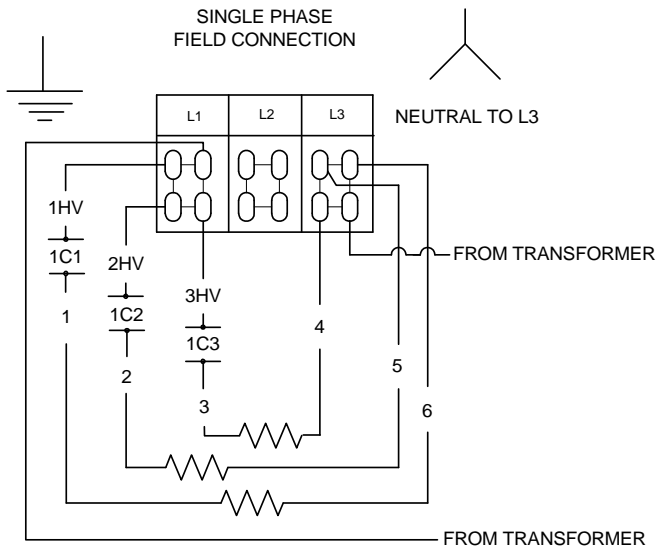

# ELECTRIC COOKER MODELS 17/8SMS, 17/8BC, 17/8C

## CHAPTER 3: OPERATING INSTRUCTIONS

---

### 3.1 Spaghetti Magic III Controller

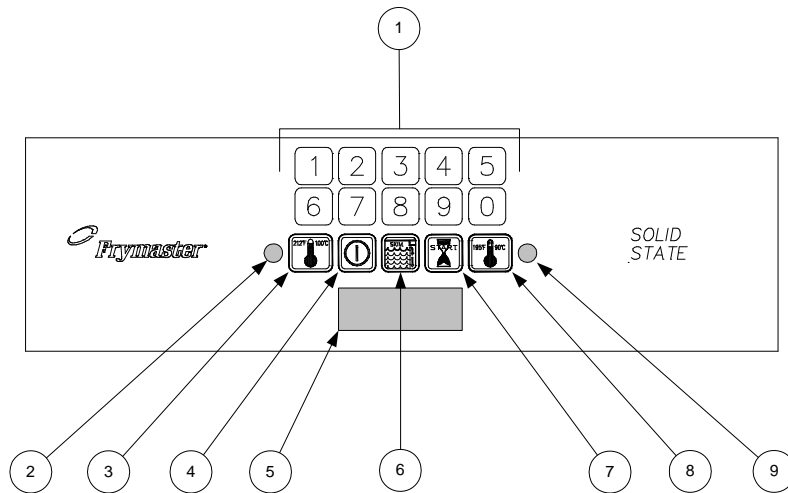

1	Numeric Keypad	6	Skim Switch (w/Autoskim only)
2	Boil Mode Indicator	7	Timer Start Switch
3	Boil Mode Switch	8	Simmer Mode Switch
4	Power Switch	9	Simmer Mode Indicator
5	LED Display		

#### 3.1.1 Introduction

The Spaghetti Magic III computer allows the operator to specify a specific cook time in minutes and seconds, then initiate a cooking cycle. The computer is configured for both automatic filling (AutoFill) and automatic skimming (Autoskim) features.

The **BOIL** mode is used when actually cooking pasta.

The **SIMMER** mode feature maintains the water temperature just below boiling (approximately 195°F/90.6°C), which conserves energy and water. This feature is designed to keep the cooker in standby.

The **SKIM** feature, when selected, adds water for approximately 3 seconds once a minute. It causes the water to overflow into the drain, carrying floating starch with it. (A buildup of starch reduces the efficiency of the cooker and can cause erroneous temperature and water level sensing.)

**LOW WATER SENSING** automatically de-energizes the heating element if the water in the cookpot drops too low. When the water level in the cookpot is below the sensor probes, such as when draining and cleaning the cookpot, the controller display will read **LO**.

**NORMAL WATER LEVEL SENSING**, on units configured with the AutoFill feature, automatically adds water during or after a cooking cycle if the water level is low. With this automatic filling feature, the water level does not have to be continuously monitored. The cookpot always has the correct amount of water.





### 3.1.2 Operating Instructions

#### CAUTION

If this is the first time the unit is being used after installation, refer to **Section 3.2, Boil Out Procedure**.

Before turning the cooker on, ensure that:

- The unit is connected to the water supply.
- The water supply is turned on.
- The unit is plugged into an appropriate outlet.
- The electrical power supply is turned on.

1. Turn the controller on by pressing the Power  switch.
2. The unit will automatically enter the simmer mode and the simmer mode indicator will illuminate. This will bring the cooker to “stand-by” temperature. To enter the boil mode, press the Boil Mode  switch.
3. Enter the desired cooking time using the numeric keypad. The time entered appears in the LED display.
4. When ready to initiate a cooking cycle, press the Start Timer  switch then press the Boil Mode  switch. The basket lift will automatically lower the basket or portion cups into the cookpot and the LED display will begin to count down. Simultaneously, the water will be raised to the boiling point. At the end of the cooking cycle, an alarm will sound briefly to alert you and the basket lift will automatically raise the basket or portion cups out of the water.
5. The display will automatically return to the previously set cooking time and the unit will return to the simmer mode. If the same time is desired for the next batch, simply repeat Step 4. If a different cooking time is desired, follow Steps 3 and 4.
6. To initiate the automatic skimming (Autoskim) feature, press the Skim  switch.

### 3.1.3 Setting the Controller Transition Temperature/Boil Intensity

You may adjust the cooker’s Transition Temperature/Boil Intensity to prevent boilover on controllers configured with this feature.

When the water is at or above the minimum temperature for boiling (transition temperature), the controller pulses power to the elements at a programmable rate. The range can be set between 0 and 9. The default setting is 5. When the water temperature is below boiling point, the power application is 100 percent.

To set the Transition Temperature/Boil Intensity:

1. Verify that the controller is OFF (the display is blank).

2. Press the Simmer (right thermometer icon) switch to enter the programming mode; *CODE* appears in the display.
3. Enter code 1111 (press the 1 button four times). *TRANSITION TEMPERATURE* appears in the display. **(NOTE:** If *TRANSITION TEMPERATURE* does not appear, your controller is not configured with this feature. Press the Simmer switch to exit the programming mode. The display will go blank.)
4. Enter the minimum temperature for boiling with the keypad. This temperature will vary with your altitude. As a guide, the table below provides boiling points for altitudes from sea level to 6000 feet (1830 meters).

Altitude		Boiling Point	
Feet	Meters	°F	°C
0	0	212	100
1000	305	210	99
2000	610	208	98
3000	915	207	97
4000	1220	205	96
5000	1525	203	95
6000	1830	201	94

5. Press the simmer switch; *5BI* (the default setting for boil intensity) appears.
6. Use the keypad to enter one of the settings from the table below.

Setting	Power ON	Power OFF
0	100%	0%
9	90%	10%
8	80%	20%
7	70%	30%
6	60%	40%
5	50%	50%
4	40%	60%
3	30%	70%
2	20%	80%
1	10%	90%

7. Press the simmer switch to lock in the new settings and exit the programming mode. The display will go blank.



### 3.1.4 Controller Simmer Mode Adjustment

**NOTE:** The SMS III Controller simmer temperature is adjustable from 185°F to 215°F (85° to 102°C).

1. Press 1, 6, 5, 0 to enter the programming mode. The currently programmed simmer setpoint will be displayed. If the setpoint is **not correct**, enter the desired setpoint (for example, press 2, 0, 0 to program the simmer setpoint to 200°).

2. Press the Simmer switch again to lock in the setpoint. Press the ON/OFF switch to turn the controller on and return to the normal operating mode.

### 3.1.5 Toggling Between Fahrenheit and Celsius Temperature Display

1. Press the Simmer  switch. *Code* appears in the display, press 1, 6, 5, 8. The display will toggle from Fahrenheit to Celsius, or from Celsius to Fahrenheit.  
Press the Boil Mode  switch to display the cookpot temperature. If an **F** follows the temperature, the display is in Fahrenheit; if a **C** follows the temperature, the display is in Celsius.

### SELECTING STANDARD OR SLOW CLOCK

The computer can be programmed for either “standard” or “slow” clock times. The standard clock displays minutes and seconds, the slow clock displays hours and minutes.

To toggle back and forth between times press the Program Mode  switch, then enter the code **1 6 5 3** using the product buttons.

### 3.2 Boiling Out the Cookpot

The cookpot must be boiled out before first use.

1. Close the drain valve and fill the cookpot with a mixture of cold water and 1 cup of detergent.
2. Place the unit into operation.
3. Press the simmer switch, , and allow the solution to simmer for at least 1 hour.
4. After the solution simmers for 1 hour, turn the unit off and add cold water until the solution is cool. Drain the solution and clean the frypot thoroughly. Rinse the cookpot at least twice by filling with clean water and draining. Dry the cookpot thoroughly with a clean, dry towel.

**NOTE:** Do not use deliming solution to clean these units. Use of deliming solution will damage all stainless steel parts.

#### **WARNING**

When cleaning around the elements, be careful not to bend or otherwise damage the high-limit thermostat capillary tube.

5. For units equipped with a rinse tank, clean the tank with a solution of dishwashing detergent and hot water. Drain the tank and dry it thoroughly with a clean, dry towel.



# ELECTRIC COOKER MODELS 17/8SMS, 17/8BC, 17/8C

## CHAPTER 4: PREVENTIVE MAINTENANCE

---

### Daily Preventive Maintenance

It is normal for a coating of starch to form on the elements, sensors, and temperature probes during operation. If the coating is allowed to build-up, it will adversely affect the operation of the equipment. The preventive maintenance routines below should be performed at least daily to keep your equipment functioning at peak efficiency.

#### Inspect Equipment and Accessories for Damage

Look for loose or frayed wires and cords, leaks, foreign material in cookpot or inside cabinet, and any other indications that the equipment and accessories are not ready for safe operation.

#### Clean Cabinet Inside and Out

Clean inside the cabinet with a dry, clean cloth. Wipe all accessible metal surfaces and components to remove accumulations of oil, dust, or cooking residue.

Clean the outside of the cabinet with a clean cloth dampened with dishwashing detergent, removing oil, dust, or cooking residue.



**DANGER**

**Never attempt to clean this equipment during the cooking process or when the cookpot is filled with hot water and/or food products.**

#### Clean Water-Level Sensors, Temperature Sensor, Element, and Cookpot

Turn the equipment off and drain the cookpot.

Clean the water level sensors (located in the front of the cookpot behind the sensor cover). Normally, a bottlebrush and a solution of detergent and water may be used to clean the sensors with the cover installed. If the sensors become coated with an unusually heavy layer of starch or lime, the cover may be removed to better access the sensors for cleaning using a Scotchbrite™ or similar abrasive pad and a solution of detergent and water.

Using a Scotchbrite™ or similar abrasive pad and a solution of detergent and water, clean the inside of the cookpot. Pay particular attention to the heating element.

Rinse the cookpot thoroughly with clean water at least twice.

# ELECTRIC COOKER MODELS 17/8SMS, 17/8BC, 17/8C

## CHAPTER 5: OPERATOR TROUBLESHOOTING

---

### 5.1 Introduction

This chapter provides an easy reference guide to the more common problems that may occur during the operation of this equipment. The troubleshooting guides in this chapter are intended to help you correct, or at least accurately diagnose, problems with the equipment. Although the chapter covers the most common problems reported, you may encounter a problem not covered. In such instances, the Frymaster Technical Service Department will make every effort to help you identify and resolve the problem.

When troubleshooting a problem, always use a process of elimination starting with the simplest solution and working through to the most complex. Never overlook the obvious. Anyone can forget to plug a cord into a receptacle or open the valve on the water supply line. Don't assume that you are exempt from such occurrences. Most importantly, try to establish a clear idea of why a problem has occurred. Part of your corrective action involves taking steps to ensure that it doesn't happen again. Keep in mind that failure of a small component may often be indicative of potential failure or incorrect functioning of a more important component or system.

If the troubleshooting and corrective actions in this chapter do not solve the problem, the problem is probably beyond the scope of most operators to solve and you should call your FAS for assistance. If you have doubts as to the proper action to take, do not hesitate to call the Frymaster Technical Service Department or your local Frymaster Factory Authorized Servicer for assistance.

*Before calling a servicer or the Frymaster HOTLINE (1-800-551-8633):*

- **Verify that electrical cords are plugged in and that circuit breakers are on.**
- **Verify that water supply valves are open and that drain valves are fully closed.**

 **DANGER**

**Hot water can cause severe burns. Never attempt to move a cooker containing hot water or to transfer hot water from one container to another.**

 **DANGER**

**Use extreme care when performing electrical circuit tests. Live circuits will be exposed.**

 **WARNING**

**Inspection, testing, and repair of electrical components should be performed only by qualified service personnel. The equipment should be unplugged when servicing, except when electrical tests are required.**

## 5.2 Operator Troubleshooting Guide

PROBLEM	PROBABLE CAUSES	CORRECTIVE ACTION
Controller does not activate.	A. No power to unit.	A. Turn on circuit breaker.
	B. Master Power switch in OFF position.	B. Place Master Power switch in ON position.
	C. Controller not turned on.	C. Push power switch.
Autofill does not add water.	A. Water not turned on.	A. Turn water on.
Autofill does not shut off when the cookpot is full.	A. Dirty upper water level sensor.	A. Clean sensor.
	B. Insufficient mineral content in water.	B. Add 1/8-cup baking soda to cookpot.
Water will not heat (controller is on, water is at normal level, but LO is not showing on the controller).	A. Dirty low water level sensor.	A. Clean sensor.
	B. Insufficient mineral content in water.	B. Add 1/8 cup baking soda to cookpot.
Water boils in simmer mode.	Controller out of adjustment.	Adjust controller in accordance with Section 3
Water temperature is too low in simmer mode.	Controller out of adjustment.	Adjust controller in accordance with Section 3
Timer does not count down.	Operator error.	Push timer start switch.
Basket Lift does not function correctly.	A. Roller jammed.	A. Adjust roller.
	B. Lifter rod jammed.	B. Check for free movement. Lubricate with white grease.
	C. Loose or misadjusted microswitch.	C. Check switch adjustment. Adjust as required.

### 5.3 Annual/Periodic System Inspection

**This appliance should be inspected and adjusted periodically by qualified service personnel as part of a regular kitchen maintenance program.**

**Frymaster recommends that this appliance be inspected at least annually by a Factory Authorized Service Technician as follows:**

#### **Rethermalizer**

- Inspect the cabinet inside and out, front and rear for excessive moisture
- Verify that the heating element wires are in good condition and that leads have no visible fraying or insulation damage and that they are free of moisture.
- Verify that heating elements are in good condition. Inspect the elements for signs of extensive dry-firing.
- Verify the heating-element amp-draw is within the allowed range as indicated on the appliance's rating plate.
- Verify that the temperature and high-limit probes are properly connected, tightened and functioning properly, and that mounting hardware and probe guards are present and properly installed.
- Verify that component box and contactor box components (i.e. computer/controller, relays, interface boards, transformers, contactors, etc.) are in good condition and free from oil and other debris.
- Verify that component box and contactor box wiring connections are tight and that wiring is in good condition.
- Verify that all safety features (i.e. contactor shields, drain safety switches, reset switches, etc.) are present and functioning properly.
- Verify that the vat is in good condition and free of leaks and that the frypot insulation is in serviceable condition.
- Verify that all wiring harnesses and connections are tight and in good condition.

**THIS PAGE INTENTIONALLY LEFT BLANK**



FRYMASTER  
8700 LINE AVENUE, SHREVEPORT, LA 71106-6800

800-551-8633  
318-865-1711

[WWW.FRYMASTER.COM](http://WWW.FRYMASTER.COM)

EMAIL: [FRYSERVICE@WELBILT.COM](mailto:FRYSERVICE@WELBILT.COM)



Welbilt offers fully-integrated kitchen systems and our products are backed by KitchenCare® aftermarket parts and service. Welbilt's portfolio of award-winning brands includes Cleveland™, Convothem®, Crem®, Delfield®, Frymaster®, Garland®, Kolpak®, Lincoln®, Merco®, Merrychef® and Multiplex®.

*Bringing innovation to the table* • [welbilt.com](http://welbilt.com)

©2022 Welbilt Inc. except where explicitly stated otherwise. All rights reserved. Continuing product improvement may necessitate change of specifications without notice.

Part Number FRY\_IOM\_8196889 11/2022