

Frymaster[®]

Your Growth Is Our Goal

1814E with FilterQuick[™]

Electric Fryer

Wiring Diagrams

This manual is updated as new information and models are released. Visit our website for the latest manual.



8 1 9 7 3 2 0
Part Number: FRY_D_8197320 07/2023



 **DANGER**

Prior to movement, testing, maintenance and any repair on your Frymaster fryer, disconnect ALL electrical power from the fryer.

1814 with FILTERQUICK™ SERIES ELECTRIC FRYER

Table of Contents

SECTION 1: Wiring Diagrams

1.1 Control Wiring	1-1
1.2 Contactor Box – Delta Configuration	1-2
1.3 Contactor Box – WYE Configuration	1-3
1.4 Basket Lift Wiring 200-250V (<i>After Jan. 2013</i>) (<i>Modular</i>)	1-4

1814E with FILTERQUICK™ SERIES ELECTRIC FRYER

SECTION 1: WIRING DIAGRAMS

1.1 Control Wiring

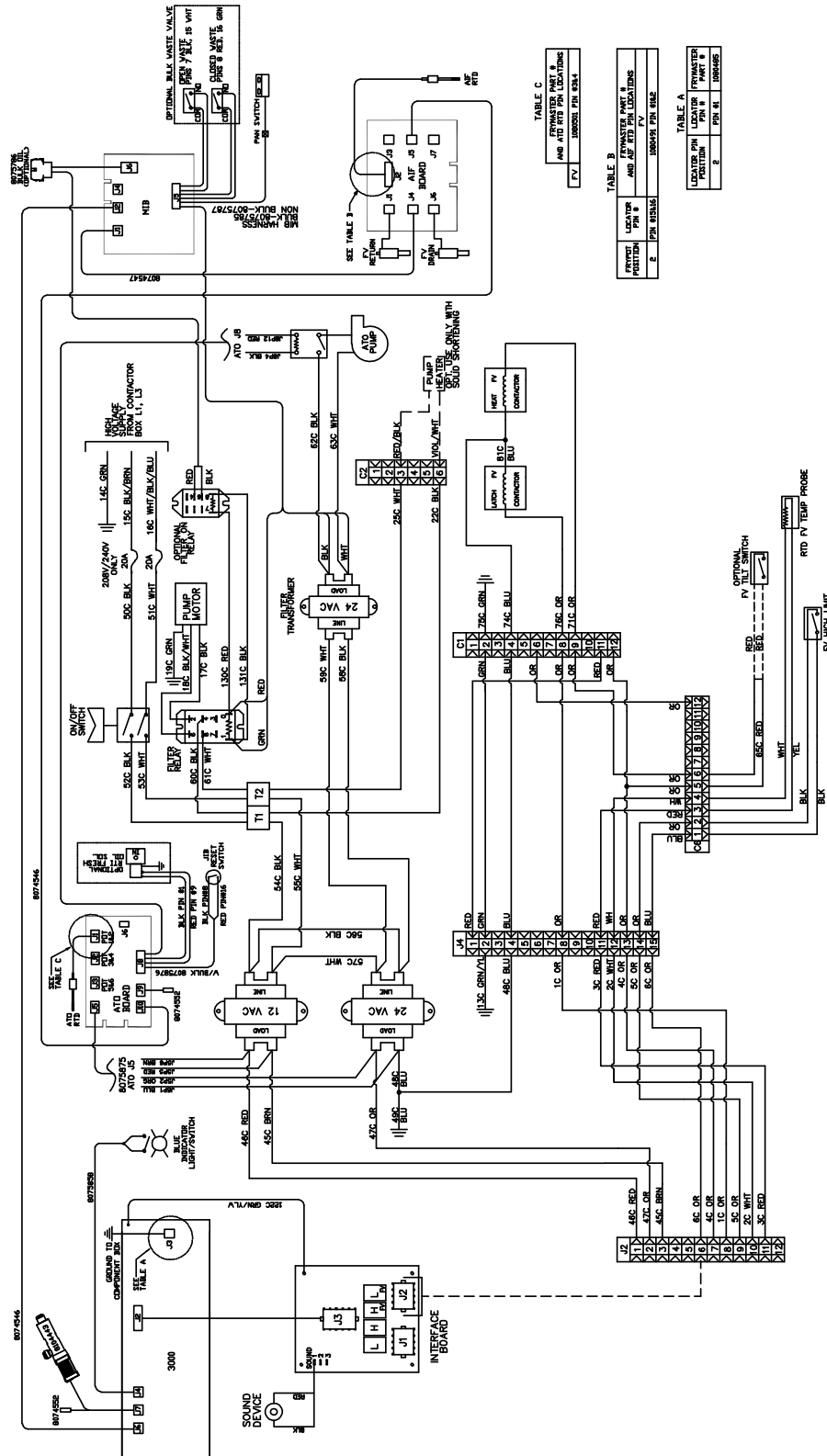

8052063C

1.2 Contactor Box – Delta Configuration

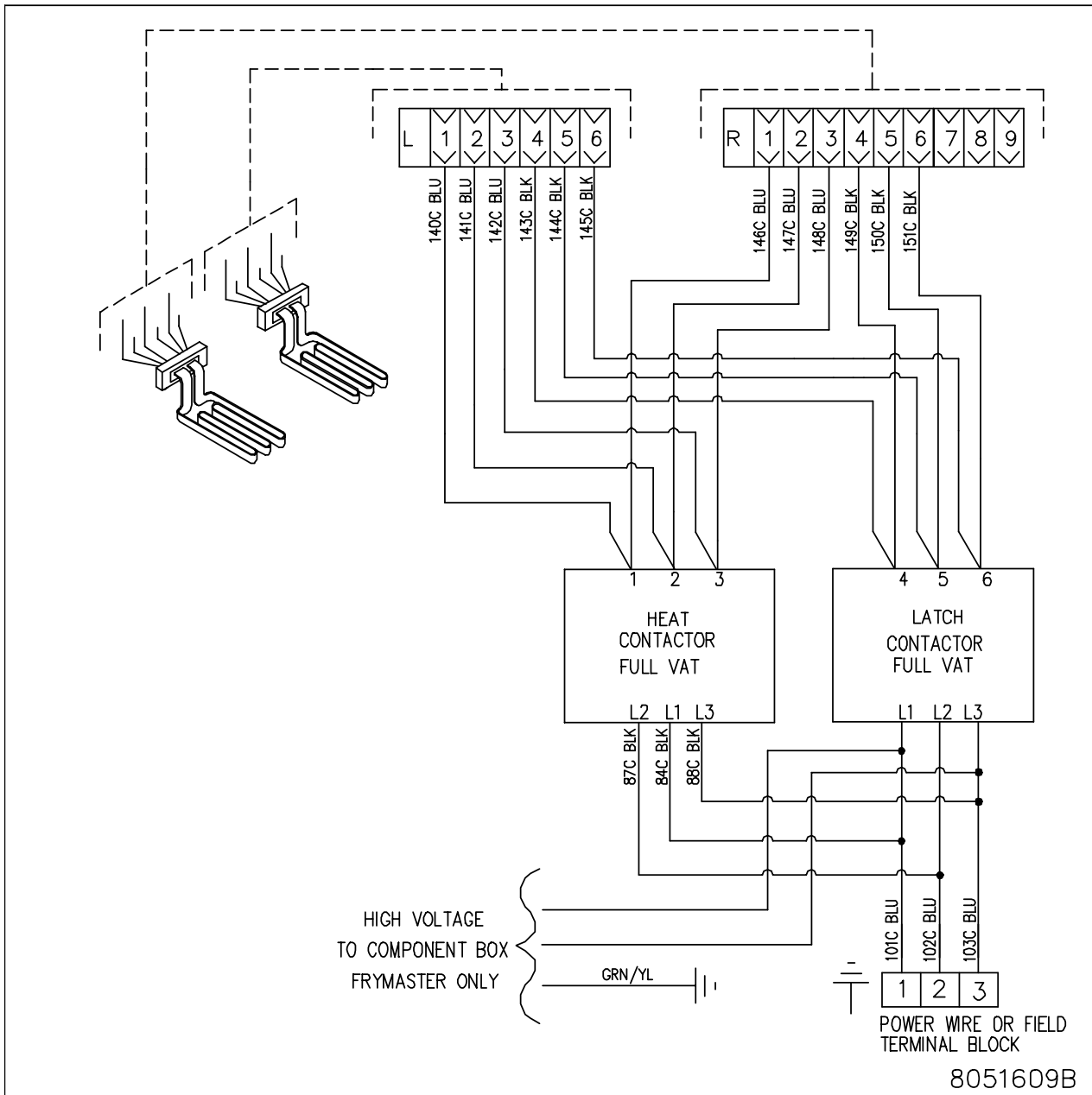

1.3 Contactor Box – WYE Configuration

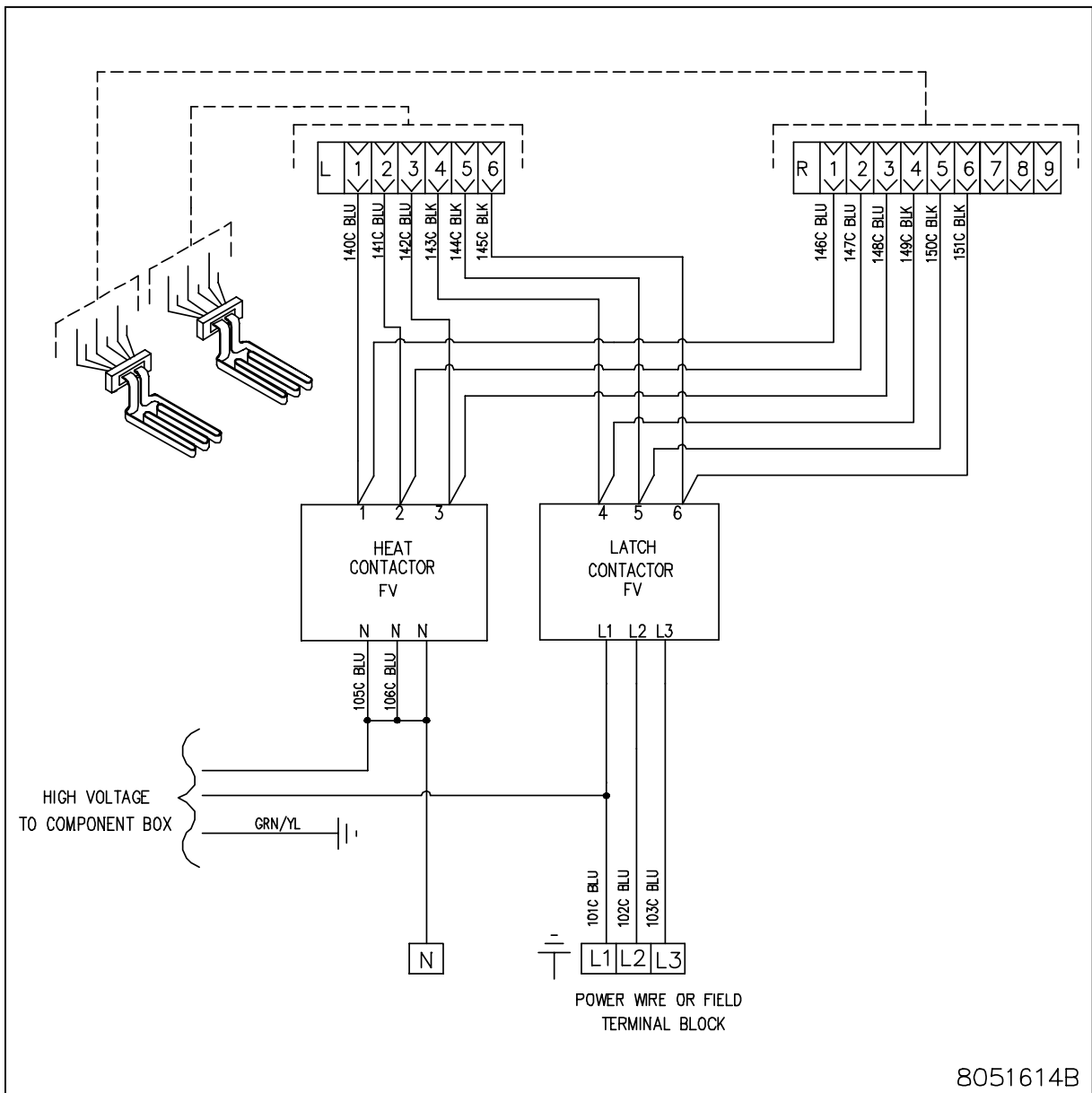

1.4 Basket Lift Wiring 200V-250V (After Jan. 2013) (Modular)

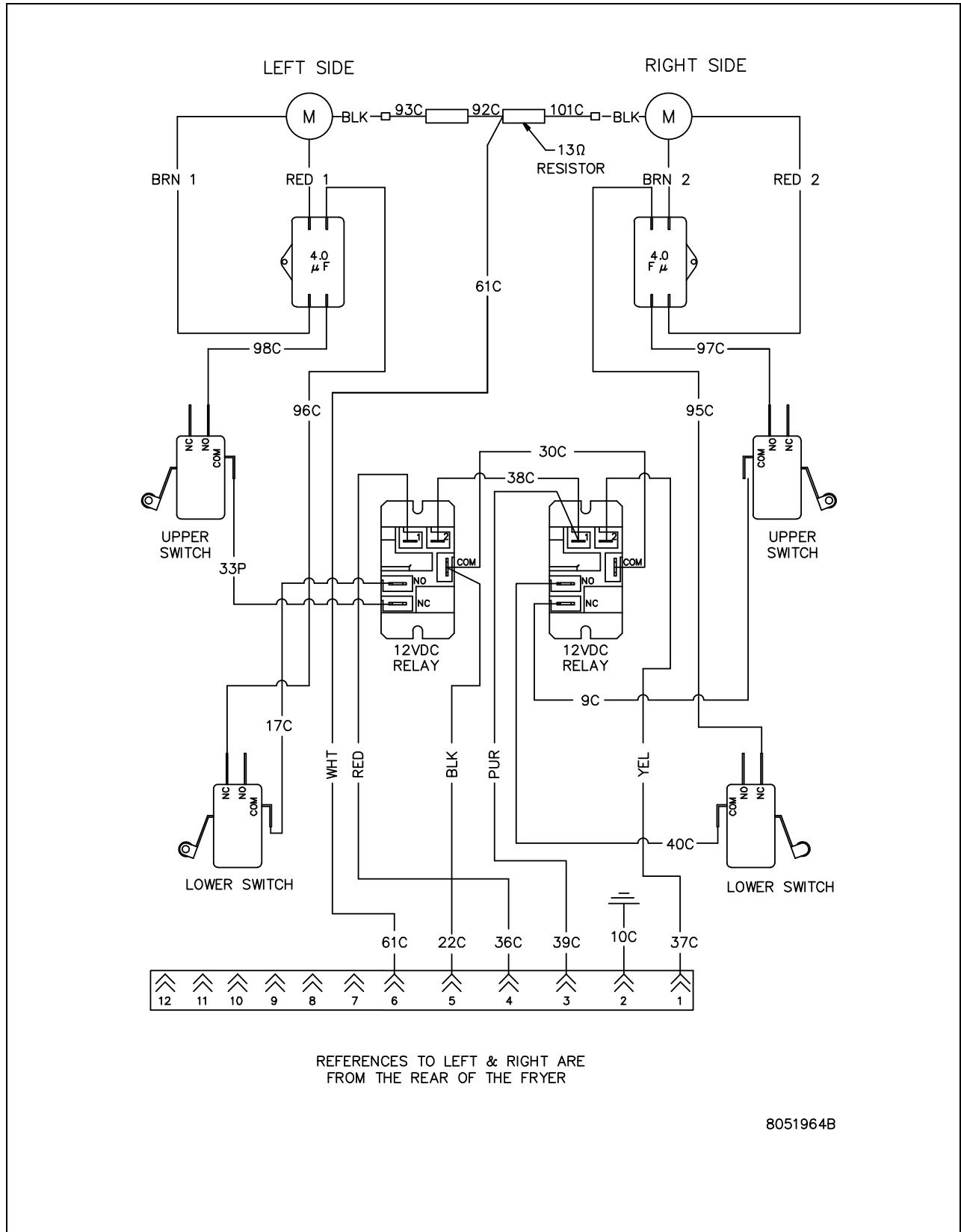

Frymaster®

FRYMASTER
8700 LINE AVENUE, SHREVEPORT, LA 71106-6800

800-551-8633
318-865-1711
WWW.FRYMASTER.COM
EMAIL: FRYSERVICE@WELBILT.COM



Welbilt offers fully-integrated kitchen systems. Welbilt's portfolio of award-winning brands includes Cleveland™, Convotherm®, Crystal Tips®, Dean®, Delfield®, Fabristeel®, Frymaster®, Garland®, Inducs®, Koldtech®, Kolpak®, Lincoln®, McCann's™, Merco®, Merrychef®, Multiplex®, RDI®, SerVend™, SunFire®, U.S. Range™, and WMaxx™. Supported by service brands: FitKitchen®, kitchen systems; and KitchenConnect®, cloud-based open platform.

Bringing innovation to the table • welbilt.com

©2023 Frymaster LLC. except where explicitly stated otherwise. All rights reserved. Continuing product improvement may necessitate change of specifications without notice.

Part Number FRY_D_8197320 07/2023