

Performance Series MJ40-MJ50 Gas Fryers

Installation, Operation and Maintenance Manual

This manual is updated as new information and models are released. Visit our website for the latest manual.



⚠ CAUTION

READ THE INSTRUCTIONS BEFORE USING THE FRYER.

FOR YOUR SAFETY

Do Not Store or use gasoline or other flammable vapors and liquids in the vicinity of this or any other appliance.

Read these instructions for use carefully so as to familiarize yourself with the appliance before connecting it to its gas supply.

Keep these instructions for future reference.



Part Number: FRY_IOM_8197397 04/2025

Original Instructions



NOTICE

IF, DURING THE WARRANTY PERIOD, THE CUSTOMER USES A PART FOR THIS FRYMASTER DEAN EQUIPMENT OTHER THAN AN **UNMODIFIED** NEW OR RECYCLED PART PURCHASED DIRECTLY FROM FRYMASTER DEAN, OR ANY OF ITS AUTHORIZED SERVICERS, AND/OR THE PART BEING USED IS MODIFIED FROM ITS ORIGINAL CONFIGURATION, THIS WARRANTY WILL BE VOID. FURTHER, FRYMASTER DEAN AND ITS AFFILIATES WILL NOT BE LIABLE FOR ANY CLAIMS, DAMAGES OR EXPENSES INCURRED BY THE CUSTOMER WHICH ARISE DIRECTLY OR INDIRECTLY, IN WHOLE OR IN PART, DUE TO THE INSTALLATION OF ANY MODIFIED PART AND/OR PART RECEIVED FROM AN UNAUTHORIZED SERVICE CENTER.

NOTICE

This appliance is intended for professional use only and is to be operated by qualified personnel only. A Frymaster Factory Authorized Servicer (FAS) or other qualified professional should perform installation, maintenance, and repairs. Installation, maintenance, or repairs by unqualified personnel may void the manufacturer's warranty. See Chapter 1 of this manual for definitions of qualified personnel.

NOTICE

This equipment must be installed in accordance with the appropriate national and local codes of the country and/or region in which the appliance is installed. See NATIONAL CODE REQUIREMENTS in Chapter 2 of this manual for specifics.

NOTICE TO U.S. CUSTOMERS

This equipment is to be installed in compliance with the basic plumbing code of the Building Officials and Code Administrators International, Inc. (BOCA) and the Food Service Sanitation Manual of the U.S. Food and Drug Administration.

 **DANGER**

Instructions to be followed in the event the operator smells gas or otherwise detects a gas leak must be posted in a prominent location. This information can be obtained from the local gas company or gas supplier.

 **WARNING**

Improper installation, adjustment, alteration, service or maintenance can cause property damage, injury, or death. Read the installation, operating, and maintenance instructions thoroughly before installing or servicing this equipment. Only qualified service personnel may convert this appliance to use a gas other than that for which it was originally configured.

 **FOR YOUR SAFETY**

Do not store or use gasoline or other flammable liquids or vapors in the vicinity of this or any other appliance.

 **DANGER**

The front ledge of the fryer is not a step! Do not stand on the fryer. Serious injury can result from slips or contact with the hot oil.

 **DANGER**

No structural material on the fryer should be altered or removed to accommodate placement of the fryer under a hood. Questions? Call the Frymaster Dean Service Hotline at 1-800-551-8633.

NOTICE

Drawings and photos used in this manual are intended to illustrate operational, cleaning and technical procedures and may not conform to onsite management operational procedures.

NOTICE TO OWNERS OF UNITS EQUIPPED WITH COMPUTERS

U.S.

This device complies with Part 15 of the FCC rules. Operation is subject to the following two conditions: 1) This device may not cause harmful interference, and 2) This device must accept any interference received, including interference that may cause undesired operation. While this device is a verified Class A device, it has been shown to meet the Class B limits.

CANADA

This digital apparatus does not exceed the Class A or B limits for radio noise emissions as set out by the ICES-003 standard of the Canadian Department of Communications.

Cet appareil numérique n'émet pas de bruits radioélectriques dépassant les limites de classe A et B prescrites dans la norme NMB-003 édictée par le Ministre des Communications du Canada.

DANGER

Do not spray aerosols in the vicinity of this appliance while it is in operation.

DANGER

The crumb tray in fryers equipped with a filter system must be emptied into a fireproof container at the end of frying operations each day. Some food particles can spontaneously combust if left soaking in certain shortening material.

WARNING

Do not bang fry baskets or other utensils on the fryer's joiner strip. The strip is present to seal the joint between the fry vessels. Banging fry baskets on the strip to dislodge shortening will distort the strip, adversely affecting its fit. It is designed for a tight fit and should only be removed for cleaning.

NOTICE

The Commonwealth of Massachusetts requires any and all gas products to be installed by a licensed plumber or pipe fitter.

WARNING

This appliance is not intended for use by children under the age of 16 or persons with reduced physical, sensory or mental capabilities, or lack of experience and knowledge, unless they have been given supervision concerning use of the appliance by a person responsible for their safety. Do not allow children to play with this appliance.

WARNING

After installation of a gas fryer and after any maintenance to the gas system of a gas fryer-manifold, valve, burners, etc. – check for gas leaks at all connections. Apply a thick soapy solution to all connections and ensure there are no bubbles. There should be no smell of gas.

DANGER

When installed, this appliance must be electrically grounded in accordance with local codes, or in the absence of local codes, with the National Electrical Code, ANSI/NFPA 70, the Canadian Electrical Code, CSA C22.2 as applicable.

DANGER

When installed, this appliance must conform with local codes, or in the absence of local codes, with the National Fuel Gas Code, ANSI Z223.1/NFPA54, or the Natural Gas and Propane Installation Code, CSA B149.1 as applicable or the appropriate national code of the country in which installed.

NOTICE

The appliance must be installed and used in such a way that any water cannot contact the fat or oil.

 **WARNING**

If the electrical power supply cord is damaged, it must be replaced by a Frymaster Factory Authorized Servicer or a similarly qualified person in order to avoid a hazard.

 **DANGER**

Adequate means must be provided to limit the movement of the appliance without depending upon the gas line connector and the quick-disconnect device or its associated piping to limit the appliance movement.

All fryers equipped with casters must be stabilized by installing restraining chains. If a flexible gas line is used, an additional restraining cable must be connected at all times when the fryer is in use.

All fryers equipped with casters must be installed using a connector that complies with the Standard for Connectors for Moveable Gas Appliances, ANSI Z21.69 or CSA 6.16, and a quick-disconnect device that complies with the Standard for Quick-Disconnect Devices for Use with Gas Fuel, ANSI Z21.41 or CSA 6.9.

NOTICE

This appliance is intended to be used for commercial applications, for example in kitchens of restaurants, canteens, hospitals and in commercial enterprises such as bakeries, butcheries, etc., but not for continuous mass production of food.

 **DANGER**

This appliance must be connected to a power supply having the same voltage and phase as specified on the rating plate located on the inside of the appliance door.

 **WARNING**

Use caution and wear appropriate safety equipment to avoid contact with hot oil or surfaces that may cause severe burns or injury.

 **WARNING**

Do not block the area around the base or under the fryers.

 **WARNING**

NEVER drain boil out or cleaning solution into a shortening disposal unit (SDU), a built-in filtration unit, a portable filter unit. These units are not intended for this purpose and will be damaged by the solution and void the warranty.

 **DANGER**

Prior to movement, testing, maintenance and any repair on your Frymaster fryer; disconnect ALL electrical power cords from the electrical power supply.

NOTICE

No warranty is provided for any Frymaster fryer used in a mobile or marine installation or concession. Warranty protection is only offered for fryers installed in accordance with the procedures described in this manual. Mobile, marine or concession conditions of this fryer should be avoided to ensure optimum performance.

 **WARNING**

Operation, installation, and servicing of this product may expose you to chemicals/products including [Bisphenol A (BPA), glass wool or ceramic fibers, and crystalline silica], which is [are] known to the State of California to cause cancer, birth defects or other reproductive harm. For more information go to www.P65Warnings.ca.gov.



**Performance Series Gas Fryers Models MJ40 & MJ50
Installation and Operation Manual**

TABLE OF CONTENTS

	Page
Chapter 1: Introduction	1-1
Chapter 2: Installation Instructions	2-1
Chapter 3: Operating Instructions	3-1
Chapter 4: Filtration Instructions	4-1
Chapter 5: Preventive Maintenance	5-1
Chapter 6: Operator Troubleshooting	6-1

PERFORMANCE SERIES GAS FRYERS MODELS MJ40 & MJ50

CHAPTER 1: GENERAL INFORMATION

1.1 Applicability and Validity

The Performance Series Gas Fryer has been approved by the European Union and the United Kingdom for sale and installation in all EU countries.

This manual is applicable to and valid for all Performance Series Atmospheric Gas Fryers sold in English-speaking countries, including those in the European Union and the United Kingdom. Where conflicts exist between instructions and information in this manual and local or national codes of the country in which the equipment is installed, installation and operation shall comply with those codes.

This appliance is only for professional use and shall be used by qualified personnel only, as defined in Section 1.7.

1.2 Parts Ordering and Service Information

In order to assist you quickly, the Frymaster Factory Authorized Servicer (FAS) or Service Department representative requires certain information about your equipment. Most of this information is printed on a data plate affixed to the inside of the fryer door. Part numbers are found in the Service, and Parts Manual. Parts orders may be placed directly with your local FAS or distributor. A list of Frymaster Factory Authorized Servicers (FAS's) is located on the Frymaster website at www.frymaster.com. If you do not have access to this list, contact the Frymaster Service Department at 1-800-551-8633 or 1-318-865-1711.

When ordering parts, the following information is required:

Model Number: _____
Serial Number: _____
Type of Gas or Voltage: _____
Item Part Number: _____
Quantity Needed: _____

Service information may be obtained by contacting your local FAS/Distributor. Service may also be obtained by calling the Frymaster Service Department at 1-800-551-8633 or 1-318-865-1711. When requesting service, please have the following information ready:

Model Number: _____
Serial Number: _____
Type of Gas: _____

In addition to the model number, serial number, and type of gas, please be prepared to describe the nature of the problem and have ready any other information that you think may be helpful in solving your problem.

RETAIN AND STORE THIS MANUAL IN A SAFE PLACE FOR FUTURE USE.

1.3 Safety Information

Before attempting to operate your unit, read the instructions in this manual thoroughly. Throughout this manual, you will find notations enclosed in double-bordered boxes similar to the ones that follow.

 **CAUTION**

CAUTION boxes contain information about actions or conditions that *may cause or result in a malfunction of your system.*

 **WARNING**

WARNING boxes contain information about actions or conditions that *may cause or result in damage to your system*, and which may cause your system to malfunction.

 **DANGER**

DANGER boxes contain information about actions or conditions that *may cause or result in injury to personnel*, and which may cause damage to your system and/or cause your system to malfunction.

Your fryer is equipped with automatic safety features:

1. High temperature detection shuts off gas to the burner assembly should the controlling thermostat fail.
2. A safety switch built into the drain valve prevents burner ignition with the drain valve even partially open.

1.4 European Community (CE) Specific Information

The European Community (CE) has established certain specific standards regarding equipment of this type. Whenever a conflict exists between CE and non-CE standards, the information or instructions concerned are identified in tables.

1.5 Equipment Description

All Performance Series fryers are of an open-frypot design with no tubes and have a hand-sized opening into the deep cold zone, which makes cleaning the frypot quick and easy.

Frypots are constructed of welded, heavy-gauge stainless steel. Heating is supplied by a burner assembly having multiple gas jets that are focused on ceramic targets located around the lower side of the frypot. The burner assembly can be configured for natural gas or propane gas. The frypot is drained with a manual ball valve.

Performance Series fryers are equipped with a thermostat probe for precise temperature control. The probe is located on the centerline of the frypot for rapid response to changes in loads and to provide the most accurate temperature measurement. Fryers in the 50-model family may have dual-vat frypots (frypots divided in half). Each half of the dual-vat frypot has its own temperature probe.

Controls on Performance Series fryers vary depending on the model and configuration purchased. Control options can include thermostat controls, digital controllers, or Computer Magic 3.5 computers. Not all models are available with all controller options. Each controller is covered in detail in the separate Frymaster Fryer Controllers User's Manual provided with your equipment.

Performance Series fryers may be equipped with an optional melt cycle feature, which pulses the burner on and off at a controlled rate. The melt cycle feature is designed to prevent scorching and uneven heating of the frypot when using solid shortening.

Fryers in this series may be configured with pilot ignition or electronic ignition. Fryers configured with electronic ignition and/or electric controls and all fryers equipped with built-in filtration require an external source of AC electrical power. Units can be configured for voltages ranging from 100 VAC to 240 VAC.

Fryers equipped with built-in filtration systems are shipped completely assembled. Fryers without built-in filtration require installation of legs or optional casters at point of use. All fryers are shipped with a package of standard accessories. Each fryer is adjusted, tested, and inspected at the factory before crating for shipment.

Model Designations

The primary difference between the fryer models in this series is the size of the frypot.

- **40** models have a frypot capacity of 30-40 pounds of cooking oil or shortening and are designed for low-volume all-purpose frying.
- **50** models have a frypot capacity of 40-50 pounds of cooking oil or shortening and are designed for high-volume frying of non-breaded products.

Fryers in the Performance series may be equipped with basket lifts (*B* in the designation) and a built-in filtration system. Fryers having a *MJ* designation have no built-in filtration. Garland Model GF16FR and the Frymaster Model AGF14 are represented by Model MJ40. Fryers having a *FMJ* designation have a built-in filtration system under the two leftmost *fryers*. Those having a *FMJ##OS* designation have a built-in filtration system under the two leftmost *stations* and a holding station. The holding station can be at any position in the battery.

40 Model Family		
Model	Built-In Filtration	Controls (Note: Millivolt controls require no external power.)
MJ*40†/GF16FR/A GF14	No	Millivolt. Thermostat knob inside door.
FMJ*40 or FPP*35	Yes	Millivolt. Thermostat knob inside door. (Requires external power supply for filter.)

* Insert the number of fryers in the battery (e.g., a MJ140 has one fryer, a MJ240 or an FMJ240 has two fryers; an FMJ240S has two fryers and one holding station, an FMJ240 has two fryers and no holding station. There is no FMJ140).

† Available with pilot ignition only.

50 Model Family		
Model	Built-In Filtration	Controls (Note: Millivolt controls require no external power.)
MJ*50†	No	Millivolt. Thermostat knob inside door.
MJ*50E	No	Electric. Digital or CM III.5 Controller.
MJ*50EC	No	Electric. CM III.5 Computer.
MJ*50EBLC	No	Electric. CM III Computer.
FMJ*50	Yes	Millivolt. Thermostat knob behind door. (Requires external power supply for filter.)
FMJ*50EC	Yes	Electric. CM III.5 Computer.
FMJ*50EBLC	Yes	Electric. CM III.5 Computer.
FMJ*50EBLM	Yes	Electric. Thermostat knob on control panel with push-button basket lift control plus ON/OFF and melt cycle switches.
FMJ*50EM	Yes	Electric. Thermostat knob on control panel with ON/OFF and melt cycle switches.

* Insert the number of fryers in the battery (e.g., a MJ150 has one fryer, a MJ250 or an FMJ250 has two fryers; an FMJ250S has two fryers and one holding station. There is no FMJ150).

† Available with pilot ignition only.

1.6 Installation, Operating, and Service Personnel

Operating information for Frymaster equipment has been prepared for use by qualified and/or authorized personnel only, as defined in Section 1.7. **All installation and service on Frymaster equipment must be performed by qualified, certified, licensed, and/or authorized installation or service personnel, as defined in Section 1.7.**

1.7 Definitions

QUALIFIED AND/OR AUTHORIZED OPERATING PERSONNEL

Qualified/authorized operating personnel are those who have carefully read the information in this manual and have familiarized themselves with the equipment functions, or who have had previous experience with the operation of the equipment covered in this manual.

QUALIFIED INSTALLATION PERSONNEL

Qualified installation personnel are individuals, firms, corporations, and/or companies which, either in person or through a representative, are engaged in and are responsible for the installation of gas-fired appliances. Qualified personnel must be experienced in such work, be familiar with all gas precautions involved, and have complied with all requirements of applicable national and local codes.

QUALIFIED SERVICE PERSONNEL

Qualified service personnel are those who are familiar with Frymaster equipment and who have been authorized by Frymaster, L.L.C. to perform service on the equipment. All authorized service personnel are required to be equipped with a complete set of service and parts manuals, and to stock a minimum amount of parts for Frymaster equipment. A list of Frymaster Factory Authorized Servicers (FAS's) is located on the Frymaster website at www.frymaster.com. *Failure to use qualified service personnel will void the Frymaster warranty on your equipment.*

1.8 Shipping Damage Claim Procedure

Your Frymaster equipment was carefully inspected and packed before leaving the factory. The transportation company assumes full responsibility for safe delivery upon its acceptance of the equipment for transport.

What to do if your equipment arrives damaged:

1. **File a claim for damages immediately**, regardless of the extent of damages.
2. **Inspect for and record all visible loss or damage** and ensure that this information is noted on the freight bill or express receipt and is signed by the person making the delivery.
3. **Concealed loss or damage** that was unnoticed until the equipment was unpacked should be recorded and reported to the freight company or carrier **immediately** upon discovery. A concealed damage claim must be submitted within 5 days of the date of delivery. Ensure that the shipping container is retained for inspection.

Frymaster DOES NOT ASSUME RESPONSIBILITY FOR DAMAGE OR LOSS
INCURRED IN TRANSIT.

PERFORMANCE SERIES GAS FRYERS MODELS MJ40 & MJ50

CHAPTER 2: INSTALLATION INSTRUCTIONS

2.1 General Installation Requirements

Qualified, licensed, and/or authorized installation or service personnel, as defined in Section 1.7 of this manual, should perform all installation and service on Frymaster equipment.

Conversion of this appliance from one type of gas to another should only be performed by qualified, licensed, and/or authorized installation or service personnel as defined in Section 1.7 of this manual.

Failure to use qualified, licensed, and/or authorized installation or service personnel (as defined in Section 1.7 of this manual) to install, convert to another gas type or otherwise service this equipment will void the Frymaster warranty and may result in damage to the equipment or injury to personnel.

Where conflicts exist between instructions and information in this manual and local or national codes or regulations, installation and operation shall comply with the codes or regulations in force in the country in which the equipment is installed.

 **DANGER**

Building codes prohibit a fryer with its open tank of hot oil/shortening being installed beside an open flame of any type, including those of broilers and ranges.

Upon arrival, remove fryer from box and inspect the fryer carefully for visible or concealed damage. (See **Shipping Damage Claim Procedure** in Chapter 1.) If there is no damage, remove fryer from pallet. Discard box and pallet.

 **DANGER**

Frymaster appliances equipped with legs are for stationary installations. Appliances fitted with legs must be lifted during movement to avoid damage to the appliance and bodily injury. For movable installations, optional equipment casters must be used. Questions? Call 1-800-551-8633.

PROPER INSTALLATION IS ESSENTIAL FOR EFFICIENT, TROUBLE-FREE OPERATION OF YOUR FRYER. ANY UNAUTHORIZED ALTERATIONS MADE TO THIS EQUIPMENT WILL VOID THE FRYMASTER WARRANTY.

CLEARANCE AND VENTILATION

 **DANGER**

No structural material on the fryer should be altered or removed to accommodate placement of the fryer under a hood. Questions? Call the Frymaster/Dean Service Hotline at 1-800-551-8633.

 **DANGER**

This appliance must be installed with sufficient ventilation to prevent the occurrence of unacceptable concentrations of substances harmful to the health of personnel in the room in which it is installed.

The fryer(s) must be installed with a 6" (150 mm) clearance at both sides and back when installed adjacent to combustible construction; no clearance is required when installed adjacent to noncombustible construction. If a flue deflector is included with the fryer, ensure that the flue deflector is installed as per the instruction sheet provided. It is recommended that a flue deflector is used for fryers installed near a wall cavity that contains combustible materials. A minimum of 24" (600 mm) clearance should be provided at the front of the fryer.

One of the most important considerations of efficient fryer operation is ventilation. Ensure the fryer is installed so that products of combustion are removed efficiently, and that the kitchen ventilation system does not produce drafts that interfere with proper burner operation.

The fryer flue opening must not be placed close to the intake of the exhaust fan, and the fryer must never have its flue extended in a "chimney" fashion. An extended flue will change the combustion characteristics of the fryer, causing longer recovery time. It also frequently causes delayed ignition. To provide the airflow necessary for good combustion and burner operation, the areas surrounding the fryer front, sides, and rear must be kept clear and unobstructed.

Fryers must be installed in an area with an adequate air supply and adequate ventilation. Adequate distances must be maintained from the flue outlet of the fryer to the lower edge of the ventilation filter bank. Filters should be installed at an angle of 45 degrees. Place a drip tray beneath the lowest edge of the filter. For U.S. installation, NFPA standard No. 96 states, "A minimum distance of 18 inches (450 mm) should be maintained between the flue outlet and the lower edge of the grease filter." Frymaster *recommends that the minimum distance be 24 inches (600 mm) from the flue outlet to the bottom edge of the filter when the appliance consumes more than 120,000 BTU per hour.*

Information on construction and installation of ventilating hoods can be found in the NFPA standard cited above. A copy of the standard may be obtained from the National Fire Protection Association, Battery March Park, Quincy, MA 02269.

NATIONAL CODE REQUIREMENTS

The type of gas for which the fryer is equipped is stamped on the data plate attached to the inside of the fryer door. Connect a fryer stamped "NAT" only to natural gas, those stamped "PRO" only to propane gas.

Installation shall be made with a gas connector that complies with national and local codes, and, where applicable, CE codes. Quick-Disconnect devices, if used, shall likewise comply with national, local, and, if applicable, CE codes. In the absence of local codes, installation must conform to the national Fuel Gas Code, ANSI Z223.1/NFPA 54 or the Natural Gas and Propane Installation code, CSA B149.1, as applicable including:

1. The appliance and its individual shutoff valve must be disconnected from the gas supply piping system during any pressure testing of the system at test pressures in excess of ½ psi (3.5 kPa).
2. The appliance must be isolated from the gas supply piping system by closing its individual manual shutoff valve during any pressure testing of the gas supply piping system at test pressures equal to or less than ½ psi (3.5 kPa).

ELECTRICAL GROUNDING REQUIREMENTS

All electrically operated appliances must be grounded in accordance with all applicable national and local codes, and, where applicable, CE codes. In the absence of local codes, the appliance must be grounded in accordance with National Electrical Code, ANSI/NFPA 70, or the Canadian Electrical Code, CSA C22.2, as applicable. All units (cord connected or permanently connected) should be connected to a grounded power supply system. A wiring diagram is located on the inside of the fryer door. Refer to the rating plate on the inside of the fryer door for proper voltages.

DANGER

If this appliance is equipped with a three-prong (grounding) plug for your protection against electrical shock, it must be plugged directly into a properly grounded three-prong receptacle. Do not cut, remove, or otherwise bypass the grounding prong on this plug!

DANGER

This equipment requires electrical power for operation. Place the gas control valve in the OFF position in case of a prolonged power outage. Do not attempt to use the equipment during a power outage.

AUSTRALIAN REQUIREMENTS

To be installed in accordance with AS 5601/ AG 601, local authority, gas, electricity, and any other relevant statutory regulations.

If casters are fitted, the installation must comply with AS5601 and AS1869 requirements.

SOUTH AFRICA REQUIREMENTS

IMPORTANT INFORMATION FOR THE USER

This appliance may only be installed by a registered SAQCC Gas installer. All registered installers are issued with a card carrying their registration number. Ask to be shown the card before allowing the installation work to commence and make a note of the Installer registration number. Upon

completion of the installation, the installer is required to explain the operational details of the appliance together with the safety instructions. You will be asked to sign acceptance of the installation and be provided with a completion certificate. You should only sign for acceptance of the installation when the installation is completed to your satisfaction. Note that your invoice is required in the event that you wish to make a guarantee claim.

IMPORTANT INFORMATION FOR THE INSTALLER.

This appliance may only be installed by a gas installer registered with the South African qualification and certification committee (SAQCC). The appliance must be installed in accordance with the requirements of SANS 10087-1 for use with LPG, SANS 827 for use with NG and any fire department regulations and/or local bylaws applicable to the area. If in doubt, check with the relevant authority before undertaking the installation. Upon completion of the installation, you are required to fully explain and demonstrate to the user the operational details and safety practices applicable to the appliance and the installation.

FCC COMPLIANCE

The user is cautioned that any changes or modifications to Frymaster computers not expressly approved by the party responsible for compliance could void the user's authority to operate the equipment. Frymaster computers have been tested and found to comply with the limits for a Class A digital device, pursuant to Part 15 of the FCC rules. While these devices are verified as Class A devices, they have been shown to meet the Class B limits. These limits are designed to provide reasonable protection against harmful interference when the equipment is operated in a commercial environment. This equipment generates, uses, and can radiate radio frequency energy and, if not installed and used in accordance with the instruction manual, may cause harmful interference to radio communications. Operation of the equipment in a residential area is likely to cause harmful interference in which case the user will be required to correct the interference at the user's expense.

If necessary, the user should consult the dealer or an experienced radio and television technician for additional suggestions.

The user may find the booklet "How to Identify and Resolve Radio-TV Interference Problems" helpful. It is prepared by the Federal Communications Commission and is available from the U.S. Government Printing Office, Washington, DC 20402, Stock No. 004-000-00345-4.

2.2 Dimensions

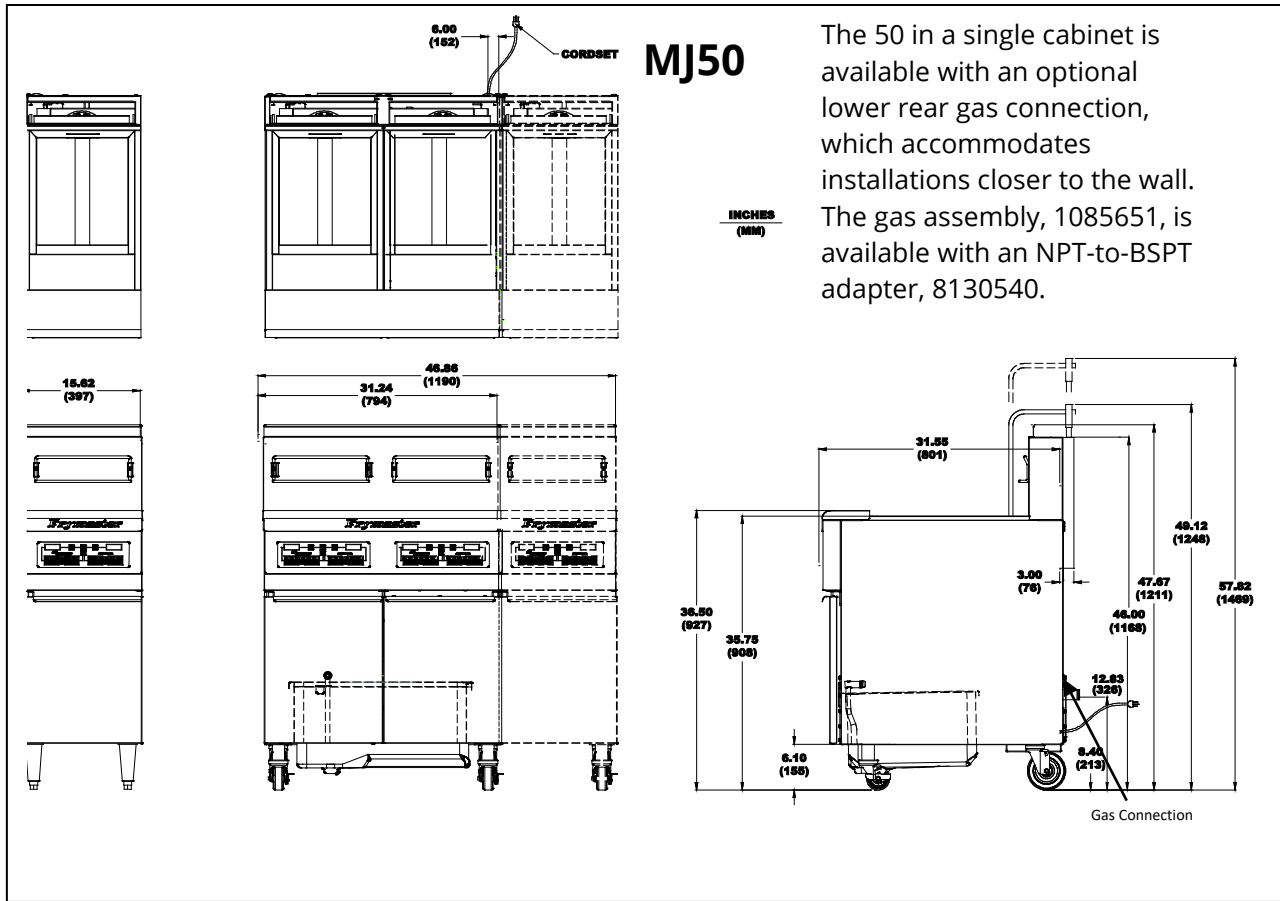

The 50 in a single cabinet is available with an optional lower rear gas connection, which accommodates installations closer to the wall. The gas assembly, 1085651, is available with an NPT-to-BSPT adapter, 8130540.

MJ40

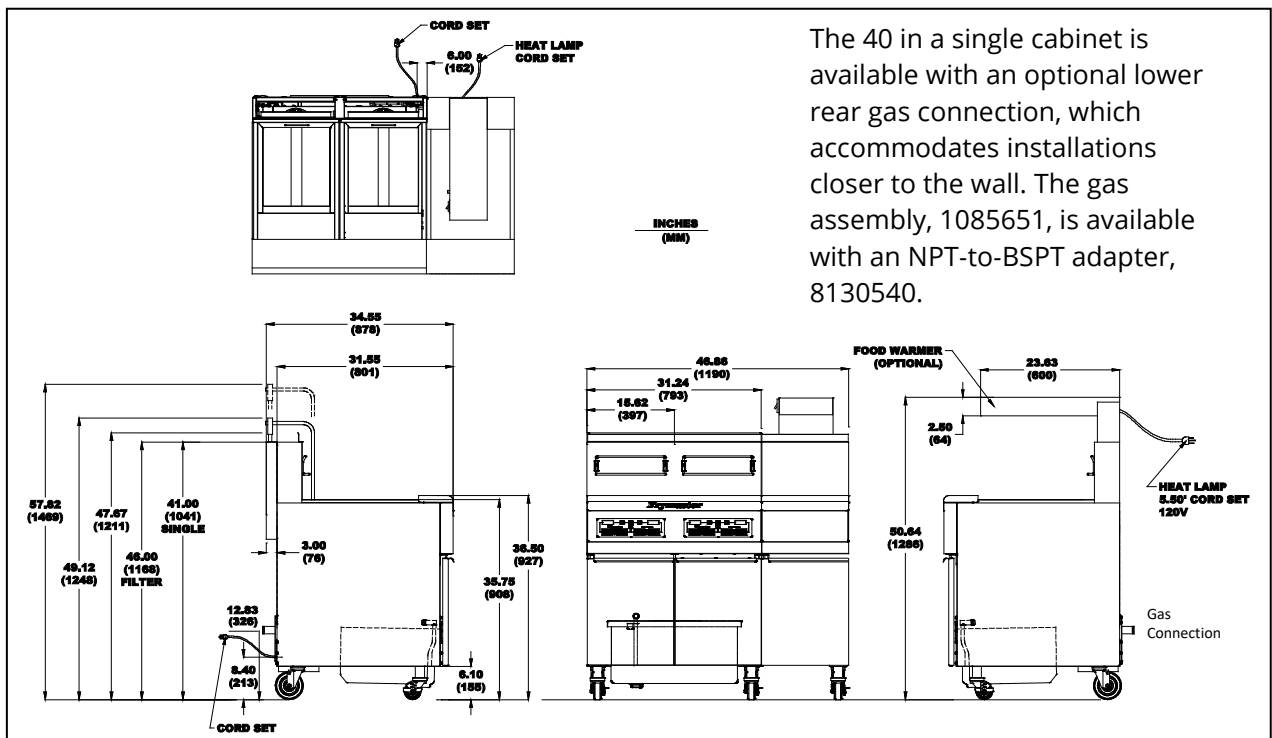

The 40 in a single cabinet is available with an optional lower rear gas connection, which accommodates installations closer to the wall. The gas assembly, 1085651, is available with an NPT-to-BSPT adapter, 8130540.

2.3 Caster/Leg Installation



DO NOT install this appliance without legs or casters.

Depending upon the specific configuration ordered, the fryer might have been shipped without installed casters or legs. If casters or legs are installed, you may skip this section and proceed to Section 2.4, Pre-Connection Preparations. **DO NOT INSTALL THIS APPLIANCE WITHOUT CASTERS OR LEGS.**

If your fryer requires the installation of casters/legs, install them in accordance with the instructions included in your accessory package.

On an appliance with casters, the installation shall be made with a connector that complies with the Standard for Moveable Gas Appliances, ANSI Z21.69 • CSA 6.16, and a quick disconnect device that complies with the Standard for Quick-Disconnect Devices for Use With Gas Fuel, ANSI Z21.41 • CSA 6.9.

2.4 Pre-Connection Preparations



Do not connect this appliance to the gas supply before completing each step in this section.

After the fryer has been positioned under the fry station exhaust hood, ensure the following has been accomplished:

1. Adequate means must be provided to limit the movement of fryers without depending upon the gas line connections and the quick-disconnect device or its associated piping to limit the appliance movement. If a flexible gas hose is used, a restraining cable must be connected at all times when the fryer is in use. The restraining cable and installation instructions are packed with the flexible hose in the accessories box that was shipped with your unit.
2. **Single unit** fryers must be stabilized by installing restraining chains on fryers equipped with casters or anchor straps on fryers equipped with legs. Follow the instructions shipped with the casters/legs to properly install the chains or straps.



Do not attach an apron drain board to a single fryer. The fryer may become unstable, tip over, and cause injury. The appliance area must be kept free and clear of combustible materials at all times.

Level fryers equipped with legs by screwing out the legs approximately 1 inch, and then adjust them so that the fryer is level and at the proper height in the exhaust hood. Frymaster recommends that the minimum distance from the flue outlet to the bottom edge of the filter be 24 inches (600 mm) when the appliance consumes more than 120,000 BTU per hour.

3. For fryers equipped with casters, there are no built-in leveling devices. The floor where the fryer is to be installed must be level.
4. Test the fryer electrical system: Verify correct voltage and connect per National codes and regulations.
 - a. Plug the fryer electrical cord(s) into a grounded electrical receptacle.
 - b. Place the power switch in the **ON** position.
 - For fryers equipped with thermostat controls, verify that the power and heat lights are lit.
 - For fryers having computer or digital displays, verify that the display indicates *CYCL*.
 - c. Place the fryer power switch in the **OFF** position. Verify that the power and heat lights are out, or that the display is blank.
5. Refer to the data plate on the inside of the fryer door to verify that the fryer burner is configured for the proper type of gas before connecting the gas line quick-disconnect device or piping from the gas supply line.
6. Verify the minimum and maximum gas supply pressures for the type of gas to be used in accordance with the accompanying tables:
7. For fryers equipped with a built-in filter system and/or basket lifts, plug the electrical cord(s) into a power receptacle behind the fryer.

NOTE: Gas specifications are included on appliance data plate located inside the door.

Non- CE Standard for Gas Pressure				
	Model 40/GF16FR		Model 50	
Gas Type	Nat	LP	Nat	LP
Min Pressure W.C/kpa/mbar	6/1.49/14.93	11/2.74/27.37	6/1.49/14.93	11/2.74/27.37
Max Pressure W.C/kpa/mbar	14/3.48/34.84	14/3.48/34.84	14/3.48/34.84	14/3.48/34.84
Orifice Size (mm)	1.7	1.05	1.45	0.86
Number of Orifices	9	9	18	18
Manifold Pressure (WC)	4	10	3.0	8.25

CE Standard for Gas Pressure				
	Model 50			
Gas Type	G20	G25	G30	G31
Rate (kW NET)	28.5			
Incoming Min Pressure (mbar)	15		28	
Incoming Max Pressure (mbar)	50		50	
Orifice Size (mm)	1.40	1.40	0.86	0.86
Number of Orifices	18	18	18	18
Manifold Pressure (mbar)	7,5	10	20,6	20,6

Australian Standard for Gas Pressure					
	Model 40/GF16FR/AGF14			Model 50	
Gas Type	Nat	LP	ULPG	Nat	LP
Min Pressure	1.13kpa	2.75 kpa	2.75 kpa	1.13kpa	2.75 kpa
Max Pressure	5.0 kpa	7.0 kpa	7.0 kpa	5.0 kpa	7.0 kpa
Orifice Size (mm)	1.7	1.05	0.86	1.20	0.81
Number of Orifices	9	9	9	18	18
Manifold Pressure	0.80 kpa	2. 5 kpa	2. 5 kpa	0.96 kpa	2.2 kpa

NOTE: Commissioning procedures for ULPG in New Zealand ONLY:

The fryer is supplied with a Maxitrol RV48. During commissioning, the Maxitrol RV48 needs to be set to ¼ turn out from fully in.

- Remove the cover of the EZSpark™ push-button battery powered ignitor and insert the AAA battery with the positive end towards the rear of the fryer (see illustration below). Replace the cover ensuring it is securely attached.

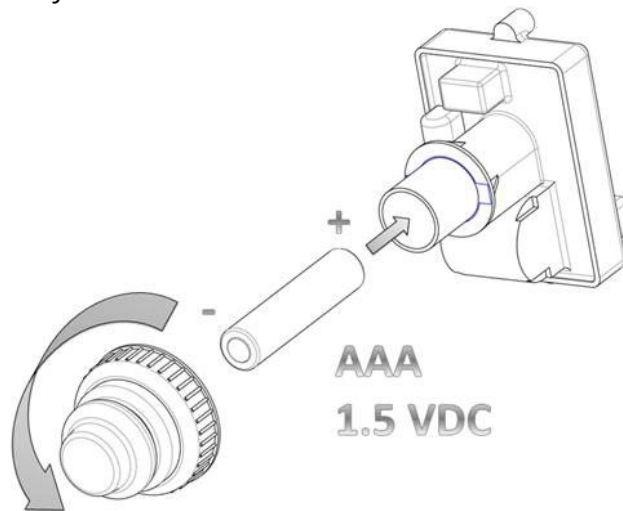

2.5 Connection to Gas Line

⚠ DANGER

Before connecting new pipe to this appliance, the pipe must be blown out thoroughly to remove all foreign material. Foreign material in the burner and gas controls will cause improper and dangerous operation.

⚠ DANGER

When pressure-testing incoming gas supply lines, disconnect the fryer from the gas line if the test pressure will be ½ PSIG (3.45 kPa, 13.84 inches W.C.) or greater to avoid damage to the fryer's gas tubes and gas valve(s).

⚠ DANGER

The appliance and its individual shutoff valve must be disconnected from the gas supply piping system during any pressure testing of that system at test pressures in excess of ½ PSIG (3.5 kPa, 14.07 inches W.C.).

⚠ DANGER

The appliance must be isolated from the gas supply piping system by closing its individual manual shutoff valve during any pressure testing of the gas supply system at test pressures equal to or less than ½ PSIG (3.5 kPa, 14.07 inches W.C.).

Performance Series Atmospheric gas fryers have received the appropriate mark for the countries and gas categories indicated in Tables 3A and 3B (below).

Country	Category	Gas	Pressure (mbar)
BE	I2E+(S)	G20/G25	20/25
	I3P	G31	37
DE	I2 ELL	G20/G25	20
	I3P	G31	50
DK-GR-IT	I2 H	G20	20
FR	I12Esi3P	G20/G25	20/25
		G31	37 ET 50
LU	I2E	G20/G25	20/25
ES	I12H3P	G20	20
		G31	37 ET 50
NL	I12L3P	G25	25
		G31	50
PT	I12H3P	G20	20
		G31	37

The size of the gas line used for installation is very important. If the line is too small, the gas pressure at the burner manifold will be low. This may cause slow recovery and delayed ignition. The incoming gas supply line should be a minimum of 1½" (38 mm) in diameter. Refer to the Table 4 (right) for the minimum sizes of connection piping.

Gas	Single Unit	2 - 3 Units	4 Units*
Natural	3/4" (19 mm)	1" (25 mm)	1-1/4" (33 mm)
Propane	1/2" (13 mm)	3/4" (19 mm)	1" (25 mm)
* For distances of more than 20 feet (6 meters) and/or more than four fittings or elbows, increase the connection by one pipe size.			

CE Standard

CE regulations require a combustion air supply of 2m³/h per kW per fryer. (See rating plate affixed to door for kW rating.)

SOUTH AFRICA REQUIREMENT (LPG FRYERS ONLY)

This appliance requires an operating pressure of 2,8 kPa at the appliance. A suitable LPG regulator that complies with the requirements of SANS 1237 must be installed.

1. Connect the quick-disconnect hose to the fryer quick-disconnect fitting under the front of the fryer and to the building gas line. The gas inlet connection will be up to 1.5" NPT (38.1mm), depending on the number of fryers in the battery. The gas connection point will be about 13" (326mm) from the floor. The left-to-right position will vary according to the number of fryers in the battery.

NOTE: Some fryers are configured for a rigid connection to the gas supply line. These units are connected to the gas supply line at the rear of the unit.

When using thread compound, use very small amounts on male threads only. Use a pipe thread compound that is not affected by the chemical action of LP gases (Loctite PST567 sealant is one such compound). DO NOT apply compound to the first two threads. Applying compound to the first two threads will cause clogging of the burner orifices and control valve.

2. Open the gas-supply valve to the fryer and check all piping, fittings, and gas connections for leaks. A soap and water solution should be used for this purpose.

DANGER

All connections must be sealed with a joint compound suitable for the gas being used and all connections must be tested with a solution of soapy water before lighting any pilots.

DANGER

Never use matches, candles, or any other ignition source to check for leaks. If gas odors are detected:

- Shut off the gas supply to the appliance at the main shut-off valve or bottle.
- Extinguish all naked flames.
- Do not operate any electrical appliances in the area.
- Ventilate the area.
- Check for leaks as detailed in this manual using a solution of soapy solution.
- Immediately contact the local gas company or an authorized service agency for service.

If odor persists, contact the dealer or gas supplier immediately.

⚠ DANGER

In the event of a burn-back, where the flame burns back to the jet, immediately turn the gas supply off at the control valve on the panel. After ensuring the flame is extinguished, wait for 1 minute and re-light the appliance in the normal manner. Should the appliance again burn back, close the control valve and call a service technician. Do not use the appliance again until the service technician has declared that it is safe to do so.

3. Close the fryer drain valve and fill the frypot with water and boil-out solution to the bottom OIL-LEVEL line at the rear of the frypot. Light the fryer and perform the boil-out procedures that are described in the "Lighting Instructions" and "Boiling Out the Frypot" topics found in Chapter 3 of this manual.

⚠ DANGER

"Dry-firing" your unit will cause damage to the frypot and can cause a fire. Always ensure that melted shortening, cooking oil, or water is in the frypot before firing your unit.

4. The burner manifold pressure should be checked at this time by the local gas company or an authorized service agent. The tables on 2-7 indicate the proper burner manifold pressures.
5. Check the thermostat calibration or temperature programmed into the computer.
 - For units equipped with thermostat controls, refer to the Thermostat Calibration instructions in Chapter 5.
 - For units equipped with other types of controllers, refer to the appropriate section of the [Frymaster Fryer Controllers User's Manual](#), provided with your equipment for instructions on programming and operating your controller.

2.6 Ensure Burner Targets Are Properly Spaced

The top edge of the metal burner target should be $\frac{3}{4}$ " (19.05mm) from the frypot side. Bend the target bracket forward or back as necessary to get a uniform spacing.

2.7 Converting to another Gas Type

Your fryer is configured at the factory for either natural gas or Propane (LP) gas.

If you desire to switch from one type of gas to another, a gas conversion kit must be installed by a Factory Authorized Servicer technician.

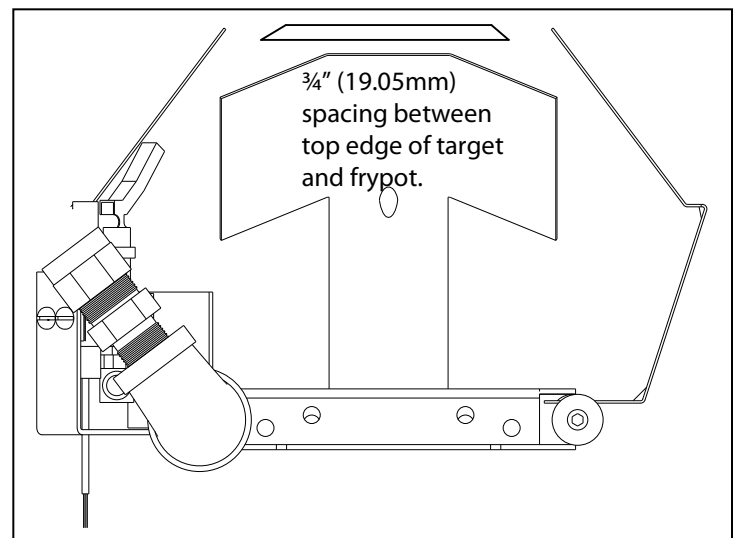

⚠ DANGER

This appliance was configured at the factory for a specific type of gas. Converting from one type of gas to another requires the installation of specific gas-conversion components.

⚠ DANGER

Switching to a different type of gas without installing the proper conversion kit may result in fire or explosion! NEVER ATTACH THIS APPLIANCE TO A GAS SUPPLY FOR WHICH IT IS NOT CONFIGURED!

⚠ DANGER

Conversion of this appliance from one type of gas to another should only be performed by qualified, licensed, and authorized installation or service personnel, as defined in Section 1.7 of this manual.

CE Gas Conversion Instructions

1. Between G20- and G25-type Natural Gas, adjust the gas pressure at the regulator. (Refer to the CE Standard Burner Manifold Gas Pressure Chart.) Do not change the orifice or pilot.
2. Between a 2nd family gas (G20 or G25) and a 3rd family gas (G31 Propane):
 - a. Change the main burner and pilot orifices.
 - b. Adjust the gas valve regulator.
 - c. Adjust the manifold pressure.
3. Affix the new label included with the conversion kit next to the existing rating plate stating that the gas type has been converted. Remove any references to the previously used gas from the existing rating plate.
4. If the destination language changes, replace the labels. Call your local service agency or kitchen equipment supplier for a label kit. The language of reference will be on the corner of the label.

The following CE gas-conversion components and kits are available from your FAS:

The gas valves can be adjusted to work with G31 (propane) as well as well as G20 and G25 (natural) gases. It only requires adjusting the regulator and changing the pilot and main burner orifices. The table below identifies the parts required to convert from one gas family to another:

Model MJ50

**Propane (G31) to Natural
(G20/G25)**

Main burner and pilot orifices kits:

Honeywell P/N 8261201

Robertshaw P/N 8260963

Natural (G20/G25) to Propane (G31)

Main burner and pilot orifices kits:

Honeywell P/N 8261202

Robertshaw P/N 8260962

Non-CE Gas Conversion Instructions

For fryers at elevations at or above 5,000 feet (1524 meters), call Frymaster Service (1-800-551-8633) to determine the components appropriate for your configuration and altitude. Contact your local FAS to order the components and arrange for installation. For fryers below 5000 feet (1524 meters), see the kits listed below for conversion.

Natural (G20/G25) to Propane (G31)

Regulator Conversion Kits:

Honeywell P/N 8071846

Robertshaw P/N 8170098

Pilot, regulator conversion kit, and orifices kits:

Honeywell P/N 8261139 (**Model 40**)

Robertshaw P/N 8260956 (**Model 40**)

Honeywell P/N 8261143 (**Model 50**)

Robertshaw P/N 8260962 (**Model 50**)

Propane (G31) to Natural (G20/G25)

Regulator Conversion Kits:

Honeywell P/N 8071849

Robertshaw P/N 8100187

Pilot, regulator conversion kit, and orifices kits:

Honeywell P/N 8261158 (**Model 40**)

Robertshaw P/N 8260961 (**Model 40**)

Honeywell P/N 8261144 (**Model 50**)

Robertshaw P/N 8260963 (**Model 50**)

Propane (G31) to Natural (G20/G25) Australian

Regulator Conversion Kit:

Honeywell P/N 8071849

Robertshaw P/N 8100187

Pilot, regulator conversion kit, and orifices kits:

Honeywell P/N 8261144 (**Model 50**)

Robertshaw P/N 8260963 (**Model 50**)

PERFORMANCE SERIES GAS FRYERS MODELS MJ40 & MJ50

CHAPTER 3: OPERATING INSTRUCTIONS

3.1 Start-Up Procedure

 **DANGER**

Never operate this appliance with an empty frypot. The frypot must be filled with water or cooking oil/shortening before lighting the burners. Failure to do so will damage the frypot and may cause a fire.

 **WARNING**

The on-site supervisor is responsible for ensuring that operators are made aware of the inherent hazards of operating a hot oil filtering system, particularly the aspects of oil filtration, draining and cleaning procedures.

 **CAUTION**

The cooking oil/shortening capacity of the 40 Series fryer is 40 lbs. (20 liters) at 70°F (21°C). For 50 Series fryers, the capacities are 50 lbs. (25 liters) for a full-vat fryer and 22.5 lbs. (12 liters) for each half of a dual-vat fryer. Before lighting the fryer, make sure the fryer is OFF and the frypot drain valve(s) is/are closed. Remove the basket support rack(s), if installed, and fill the frypot to the bottom OIL LEVEL line. If solid shortening is being used, make sure it is packed down into the bottom of the frypot.

NOTE: The pilot must be manually lit before the fryer can be placed into operation. On fryers configured with electronic ignition, the pilot is automatically lit when the unit is turned on.

Ensure that the following steps are done in sequence before lighting or re-lighting the pilot:

1. Turn the operating thermostat to the lowest setting or turn off the controller.
2. If so equipped, turn off the manual shut-off valve on the incoming gas line.
3. Fill the frypot with oil, liquid shortening or water to the bottom OIL LEVEL line scribed on the frypot back. *If using solid shortening, pre-melt the shortening prior to filling the frypot.*
4. *Non-CE:* Turn the gas valve knob to the OFF position. *CE:* Depress the OFF button (red) on the safety control valve to turn the valve off.
5. Wait at least 5 minutes for any accumulated gas to disperse.
6. If so equipped, turn on the manual shut-off valve on the incoming gas line.

ACCESSING THE PILOT

In full-vat units, the pilot is mounted on the left side of the burner manifold and is accessed through an opening in the front frypot insulation. In dual-vat units, there is a pilot on both the left and the right halves of the burner manifold.

LIGHTING THE PILOT ON FRYERS WITH NON-CE HONEYWELL/ROBERTSHAW AND CE ROBERTSHAW GAS VALVES

1. Ensure power to the unit is OFF, then turn the gas valve knob to the OFF position. Wait at least 5 minutes, then rotate the gas valve knob to the PILOT position (see Figure 1).

Lighting the Pilot

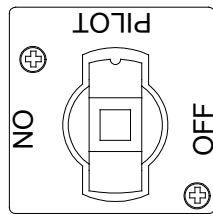

Figure 1

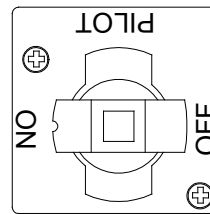

Figure 2

2. While depressing the gas valve, push the ignitor knob in until the pilot lights. Continue to hold the knob in for about 60 seconds after the flame appears on the pilot. Release the knob. The pilot should remain lit.

CAUTION

If the pilot fails to remain lit, turn the gas valve knob to the OFF position and wait at least five minutes before attempting to re-light.

3. With the pilot lit, push down and slowly turn the knob to the ON position (see Figure 2 above). Once the pilot has been lit, the burner will automatically light whenever the thermostat is set above its lowest setting or the controller calls for heat.

LIGHTING THE PILOT ON FRYERS EQUIPPED WITH CE APPROVED GAS VALVES

1. Ensure power to the unit is OFF, then press the OFF (red) button on the gas valve (see photo below). Wait at least 5 minutes.

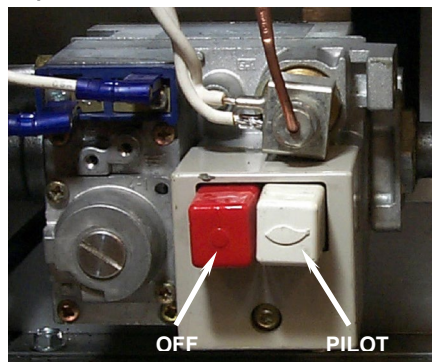

CE Honeywell gas valve (24V)

2. Press and hold the pilot (white) button, then repeatedly press the ignitor button until the pilot lights.
3. Failure to hold the button in long enough will cause the pilot to go out when the button is released. If the pilot goes out when the button is released, wait at least 5 minutes then repeat this step.

NOTES ABOUT FRYERS WITH ELECTRONIC IGNITION SYSTEMS

WARNING

Never use a match or taper to light the pilot on electronic ignition systems.

When the controller power switch is placed in the ON position, the ignition module will turn the pilot gas supply on and provide an ignition spark. The spark will light the pilot. A flame sensor verifies the presence of the pilot flame. Unless the pilot flame is sensed, the ignition module will not allow the gas valve to supply gas to the burners. The controller controls the firing of the burners after pilot ignition takes place.

If the pilot flame fails, the ignition module will shut down and “lock out” the system. To restart the system, turn the controller OFF, wait approximately 5 minutes for the system to recycle itself, then turn the controller ON again.

WARNING

In the event of prolonged power failure, the ignition module will shut down and “lock out” the system. Turn the controller OFF and then back ON after power has been re-established.

PLACING THE FRYER INTO OPERATION

CAUTION

If this is the first time the fryer is being used after installation, refer to Section 3.2, Boil-Out Procedure.

For units equipped with Thermostat Controls:

Set the thermostat knob to the desired cooking temperature. The U-shaped burner should ignite and burn with a strong, blue flame.

For units equipped with controllers other than Thermostat Controls:

Place the controller ON/OFF switch in the ON position and set the controller to – or program the controller for – the desired cooking temperature, referred to as the *setpoint*. The U-shaped burner will light and burn with a strong, blue flame. The unit automatically enters the Melt Cycle mode if the frypot temperature is below 180°F (82°C). (**NOTE:** During the melt cycle, the burner will repeatedly fire for a few seconds, then go out for a longer period.) When the frypot temperature reaches 180°F (82°C), the unit will automatically switch to the Heating mode. The burner will remain lit until the frypot temperature reaches the programmed cooking temperature (setpoint).

3.2 Boiling-Out the Frypot

To ensure that the frypot is free of any contamination resulting from its manufacture, shipping, and handling during installation, the frypot must be boiled out before first use. Frymaster recommends boiling out the frypot each time the oil or shortening is changed.

 **DANGER**

Never leave the fryer unattended during the boil-out process. If the boil-out solution boils over, turn the fryer off immediately and let the solution cool for a few minutes before resuming the process. To lessen the chance of boil over, turn the fryer's gas valve knob to the PILOT position occasionally.

1. Before lighting the burner, close the fryer drain valve(s) and fill the frypot to the bottom OIL-LEVEL line with a mixture of cold water and automatic dishwasher liquid.

2. For units equipped with a *Thermostat*, set the thermostat to 250°F (21°C).

For units equipped with a *Digital Controller*, set the setpoint to 195°F (91°C).

For units equipped with a *Computer Magic III.5 Controller*,

- Press the Power switch followed by the Program Mode switch . Code will appear in the left display.
- Enter the code number 1653. The right display will read boil. The temperature is automatically set for 195°F (91°C). The fryer will attain this temperature and remain there until the Power switch is pressed, which cancels the boil-out mode.
- For millivolt units - cycle the gas valve on and off to prevent boil over.
- For non-millivolt MJ50 units - turn power switch on and off to prevent boil over.

3. Place the fryer into operation in accordance with Section 3.1.

4. Simmer the solution for 1 hour.

5. After the solution simmers for 1 hour, turn the fryer off, allow the solution to cool, then add 2 gallons (8 liters) of cold water and stir. Drain the solution into a suitable container and clean the frypot thoroughly.

 **WARNING**

Do not drain boil-out solution into a shortening disposal unit (SDU), a built-in filtration unit, or a portable filter unit. These units are not intended for this purpose and will be damaged by the solution and void the warranty.

6. Rinse the frypot at least twice by filling the frypot with clean water and draining. Dry the frypot thoroughly with a clean, dry towel.

 **DANGER**

Remove all drops of water from the frypot before filling with cooking oil or shortening. Failure to do so will cause spattering of hot liquid when the oil or shortening is heated to cooking temperature and may cause injury to nearby personnel.

3.3 Shutting the Fryer Down

For short-term shut down during the workday, place the fryer power switch in the "OFF" position and put the frypot covers in place (if the fryer is so equipped).

When shutting the fryers down at closing time, place the fryer power switch in the "OFF" position, place the gas valve in the "OFF" position, and put the frypot covers in place (if the fryer is so equipped).

3.4 Controller Operation and Programming

Fryers in the Performance Series can be equipped with Computer Magic III.5 (CM III.5) controller, Digital Controllers, or Thermostat Controllers. Instructions for using each type are included in the separate *Frymaster Fryer Controllers User's Manual* provided with your equipment.

PERFORMANCE SERIES GAS FRYERS MODELS MJ40 & MJ50

CHAPTER 4: FILTRATION INSTRUCTIONS

WARNING

The on-site supervisor is responsible for ensuring that operators are made aware of the inherent hazards of operating a hot oil filtering system, particularly the aspects of oil filtration, draining and cleaning procedures.

4.1 Draining and Manual Filtering

DANGER

Draining and filtering of cooking oil or shortening must be accomplished with care to avoid the possibility of a serious burn caused by careless handling. The oil to be filtered is at or near 350°F (177°C). Ensure all hoses are connected properly and drain handles are in their proper position before operating any switches or valves. Wear all appropriate safety equipment when draining and filtering cooking oil or shortening.

DANGER

Allow oil/shortening to cool to 100°F (38°C) before draining into an appropriate container for disposal.

DANGER

Do not drain more than one frypot at a time into the built-in filtration unit to avoid overflow and spillage of hot oil/shortening.

DANGER

When draining oil/shortening into a disposal unit or portable filter unit, do not fill above the maximum fill line located on the container.

If your fryer is not equipped with a built-in filtration system, the cooking oil or shortening must be drained into another suitable container. (For safe, convenient draining and disposal of used cooking oil or shortening, Frymaster recommends using the Frymaster Shortening Disposal Unit (SDU). The SDU is available through your local distributor.)

1. Turn the fryer power switch to the **OFF** position. Screw the drainpipe (provided with your fryer) into the drain valve. Make sure the drainpipe is firmly screwed into the drain valve and that the opening is pointing down.
2. Position a metal container with a sealable cover under the drainpipe. The metal container must be able to withstand the heat of the cooking oil/shortening and hold hot liquids. If you intend to reuse the oil or shortening, Frymaster recommends that a Frymaster filter cone holder and filter cone be used when a filter machine is not available. If you are using a

Frymaster filter cone holder, be sure that the cone holder rests securely on the metal container.

3. Open the drain valve slowly to avoid splattering. If the drain valve becomes clogged with food particles, use the Fryer's Friend (poker-like tool) to clear the blockage.

 **DANGER**

NEVER attempt to clear a clogged drain valve from the front of the valve! Hot oil or shortening will rush out creating the potential for severe burns.

DO NOT hammer on the drain valve with the cleanout rod or other objects. Damage to the ball inside will result in leaks and will void the Frymaster warranty.

4. After draining the oil/shortening, clean all food particles and residual oil/shortening from the frypot. BE CAREFUL, this material may still cause severe burns if it comes in contact with bare skin.
5. Close the drain valve securely and fill the frypot with clean, filtered or fresh cooking oil or solid shortening to the bottom OIL-LEVEL line.

 **DANGER**

When using solid shortening, pack the shortening down into the bottom of the frypot. DO NOT operate the fryer with a solid block of shortening sitting in the upper portion of the frypot. This will cause damage to the frypot and may cause a flash fire.

4.2 Preparing the Built-In Filtration System for Use

The built-in filtration system allows the cooking oil or shortening in one frypot to be safely and efficiently filtered while the other frypots in a battery remain in operation. The built-in filtration system is available in three different configurations:

- Filter Paper – includes crumb screen, large hold-down ring, and metal filter screen.
- Filter Pad – includes crumb screen, small hold-down ring, and metal filter screen.
- Magnesol Filter – includes crumb screen and Magnesol filter assembly.

Section 4.2.1 covers preparation of the Filter Paper and Filter Pad configurations for use. Refer to Section 4.2.2 for instructions on preparing the Magnesol Filter configuration for use. Operation of all three configurations is the same and is covered in section 4.3. Disassembly and reassembly of the Magnesol filter is covered in section 4.4.

4.2.1 Preparation for Use with Filter Paper or Filter Pad

1. Pull the filter pan out from the cabinet and remove the crumb screen, hold-down ring, and filter screen.

The filter pan is equipped with rollers in rails, much like a kitchen drawer. The pan may be removed for cleaning or to gain access to interior components by lifting the front of the pan to disengage the front rollers, then pulling it forward until the rear rollers clear the rails. The pan cover must not be removed except for cleaning, interior access, or to allow a shortening disposal unit (SDU) to be positioned under the drain.



Remove the crumb screen, hold-down ring, and filter screen from the pan. Clean all components with a solution of detergent and hot water, then dry thoroughly.

2. Inspect the filter pan connection fitting to ensure that both O-rings are in good condition.

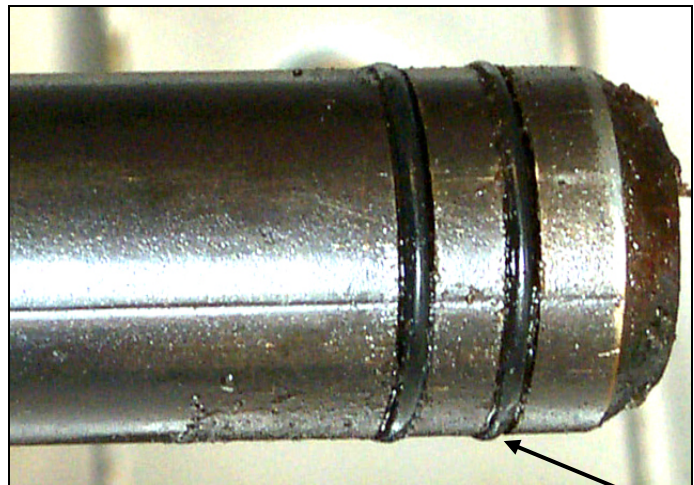

Inspect the filter connection fitting O-rings.

3. Place the metal filter screen in the center of the bottom of the pan.

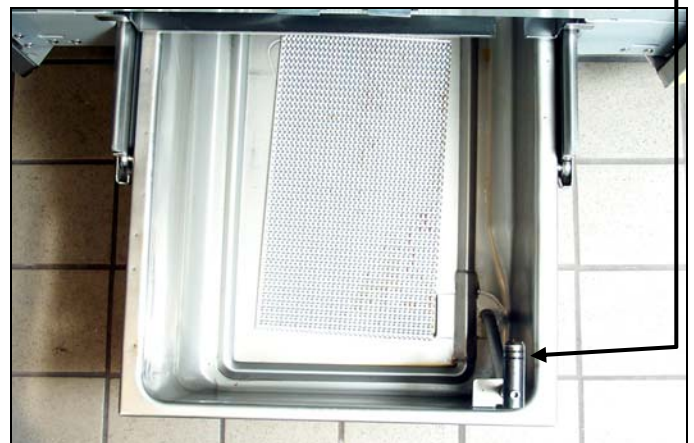

Place the filter screen in the bottom of the filter pan.

4. Lay a sheet of filter paper over the screen, overlapping on all sides, or, if using a filter pad, lay the pad over the screen.



Lay a sheet of filter paper or a filter pad over the screen. *If using the PAD, ensure the rough side of the pad is up.*

5. Install the hold-down ring over the paper or the pad.



If using filter paper, position the hold-down ring over the filter paper and lower the ring into the pan, allowing the paper to fold up around the ring as it is pushed to the bottom of the pan. When the hold-down ring is in position, sprinkle one cup of filter powder evenly over the paper.

If using a filter pad, position the hold-down ring on top of the pad. DO NOT use filter powder with the pad.

6. Replace the crumb screen in the filter pan, then push the filter pan back into the fryer, positioning it all the way to the back of the cabinet.

4.2.2 Preparation for Use with the Magnesol Filter Assembly

1. Pull the filter pan out from the cabinet and remove the crumb screen and Magnesol filter assembly.

The filter pan is equipped with rollers in rails, much like a kitchen drawer. The pan may be removed for cleaning or to gain access to interior components by lifting the front of the pan to disengage the front rollers, then pulling it forward until the rear rollers clear the rails. The pan cover must not be removed except for cleaning, interior access, or to allow a shortening disposal unit (SDU) to be positioned under the drain.

NOTE: Refer to Section 4.4 for instructions on how to disassemble and reassemble the Magnesol filter screen assembly.



Remove the crumb screen and filter assembly from the pan. Clean all components with a solution of detergent and hot water, then dry thoroughly.

2. Inspect the fitting on the bottom of the Magnesol filter assembly to ensure that the O-ring is present and in good condition.

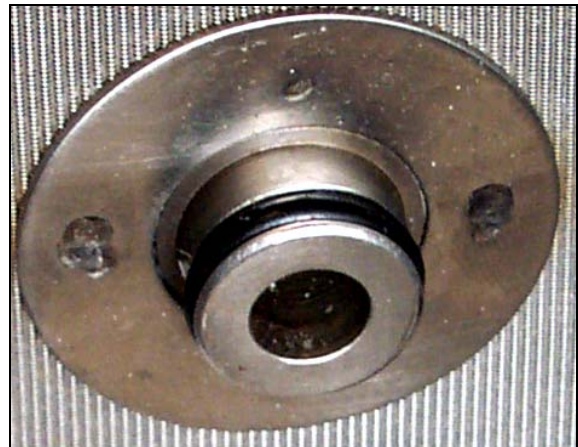

Inspect the filter screen O-ring.

3. Inspect the filter pan connection fitting to ensure that both O-rings are present and in good condition.

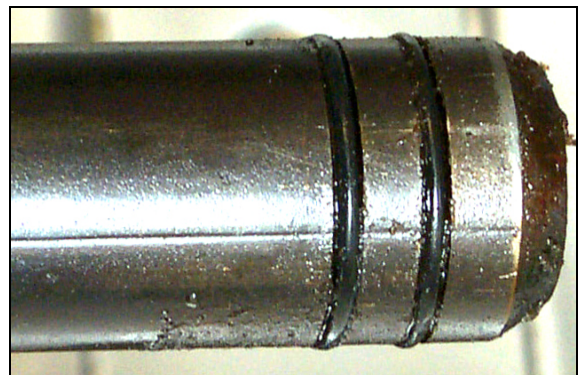

Inspect the filter connection fitting O-rings.

4. Replace the Magnesol filter assembly in the filter pan.



Replace the filter assembly in the filter pan, ensuring that the fitting on the bottom of the assembly is securely seated in the port in the bottom of the pan. Sprinkle one cup of Magnesol XL filter powder evenly over the screen.

5. Replace the crumb screen, then push the filter pan back into the fryer, positioning it all the way to the back of the cabinet.

4.3 Operation of the Filter

DANGER

Draining and filtering of cooking oil or shortening must be accomplished with care to avoid the possibility of a serious burn caused by careless handling. The oil to be filtered is at or near 350°F (177°C). Ensure drain handles are in their proper position before operating any switches or valves. Wear all appropriate safety equipment when draining and filtering cooking oil or shortening.

DANGER

NEVER attempt to drain cooking oil or shortening from the fryer with the burners lit! Doing so will cause irreparable damage to the frypot and may cause a flash fire. Doing so will also void the Frymaster warranty.

1. Turn the fryer power OFF. Drain **ONE** of the frypots into the filter pan. If necessary, use the **Fryer's Friend** clean-out rod to clear the drain from **inside** the frypot.



Rotate **ONE** of the drain valve handles to the left to open a drain valve.

⚠ DANGER

Do not drain more than one frypot at a time into the built-in filtration unit to avoid overflow and spillage of hot oil/shortening.

⚠ DANGER

NEVER attempt to clear a clogged drain valve from the front of the valve! Hot oil or shortening will rush out creating the potential for severe burns.

DO NOT hammer on the drain valve with the cleanout rod or other objects. Damage to the ball inside will result in leaks and will void the Frymaster warranty.

2. After the cooking oil has drained from the frypot, rotate the Oil Return handle left to the RETURN position to start the pump and begin the filtering process. There may be a slight delay before the pump activates. On fryers equipped with an optional rear- disposal system (See Section 4.6), rotating the handle to the right will discharge the oil.

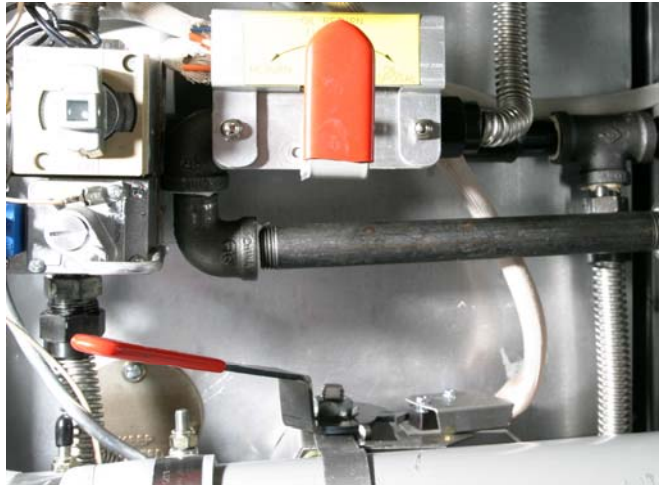

Rotate the handle to the left to return oil to the frypot. Rotate to the right on fryers with optional rear- discharge to dispose of the oil.

3. The filter pump draws the cooking oil/shortening through the filter medium and circulates it back up to and through the frypot during a 5-minute process called polishing. Polishing cleans the oil by trapping solid particles in the filter medium.
4. After the oil is filtered (about 5 minutes), close the drain valve and allow the fryer to refill. Let the filter pump run 10 to 12 seconds after the oil begins to bubble. Turn the filter off.

⚠ WARNING

The filter pump is equipped with a manual reset switch in case the filter motor overheats or an electrical fault occurs. If this switch trips, turn off power to the filter system and allow the pump motor to cool 20 minutes before attempting to reset the switch (see photo below). To access the switch, reach in from the front of the fryer.



Filter Pump Reset Switch (Arrow)

7. Ensure the drain valve is fully closed. (If the drain valve is not fully closed, the fryer will not operate.) Turn the fryer ON and allow the cooking oil to reach setpoint.

⚠ DANGER

The crumb screen in fryers equipped with a filter system must be emptied into a fireproof container at the end of frying operations each day. Some food particles can spontaneously combust if left soaking in certain shortening material.

⚠ WARNING

Do not bang fry baskets or other utensils on the fryer's joiner strip. The strip is present to seal the joint between the fry vessels. Banging fry baskets on the strip to dislodge shortening will distort the strip, adversely affecting its fit. It is designed for a tight fit and should only be removed for cleaning.

4.4 Disassembly and Reassembly of the Magnesol Filter

Disassembly

1. Grasp the frame with your thumbs on the handles at the corner of the assembly and pull outward in opposite directions to separate the frame at the corner. Continue to open the frame (it will pivot at the opposite corner) until the outer screens and grid can be removed from the frame.

Step 2 - Separate the outer screens and grid.

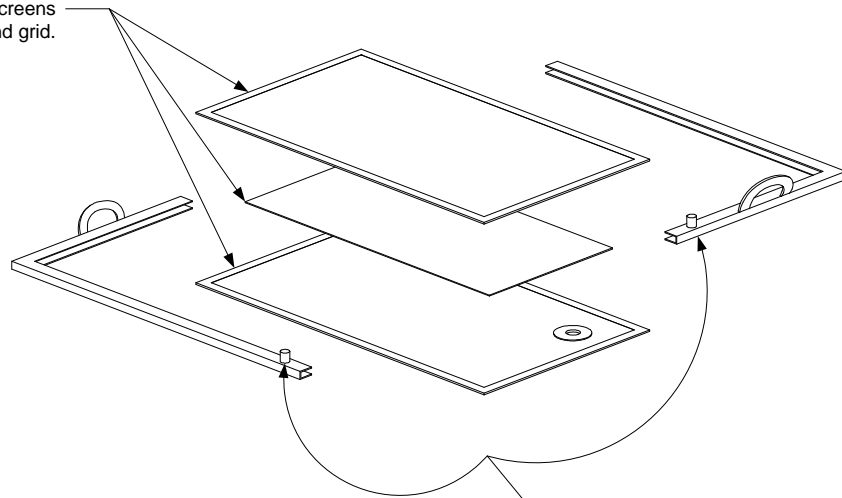

Step 1 - Grasp frame with thumbs on these handles and pull frame apart at corner.

2. Separate the outer screens and grid.

Cleaning

1. Daily – Clean the outer screens, grid, and frame using a good quality degreaser and hot water from a spray nozzle. The groove in the seal frame pieces can be cleaned with the edge of a Scotch-Brite™ or similar cleaning pad.

Allow all filter assembly components to air dry or thoroughly dry with clean towels before reassembling.

2. Additionally, at each scheduled boil-out, disassemble the leaf filter assembly and place in the frypot being boiled out. Follow the boil-out procedure in Section 5.1.2 of this manual.

Reassembly

1. Place the two outer screens together and align their edges (see illustration on following page).
2. Insert the screens into one of the frame halves (it doesn't matter which one). Ensure that the fitting in the bottom screen is on the opposite side of the frame from the handle.
3. Slip the grid between the screens, ensuring that the grid is centered between the edges of the screens.

4. Connect the other half of the frame at the corner opposite the handles and pivot the frame onto the free edges of the screen.

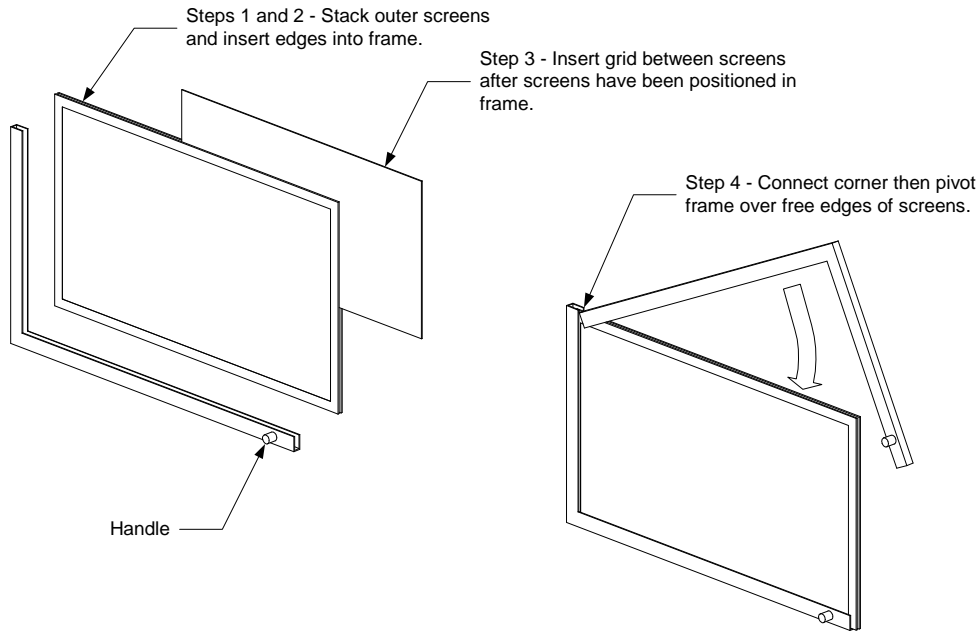

4.5 Draining and Disposing of Waste Oil

When your cooking oil/shortening has reached the end of its usable life, drain the oil/shortening into an appropriate container for transport to the disposal container. Frymaster recommends the use of the Frymaster Shortening Disposal Unit (SDU). **NOTE:** The filter pan lid must be removed from the fryer to allow the SDU to fit under the drain. To remove the lid, lift up on the front edge and pull it straight out of the cabinet. Refer to the documentation furnished with your disposal unit for specific operating instructions. If a shortening disposal unit is not available, allow the oil/shortening to cool to 100°F (38°C), then drain the oil or shortening into a metal stockpot or similar metal container. When draining is finished, close the fryer drain valve securely.

⚠ DANGER

Allow oil/shortening to cool to 100°F (38°C) before draining into an appropriate container for disposal. When draining oil/shortening into a disposal unit, do not fill above the maximum fill line located on the container.

4.5.1 Disposing of Oil with Optional Rear Discharge

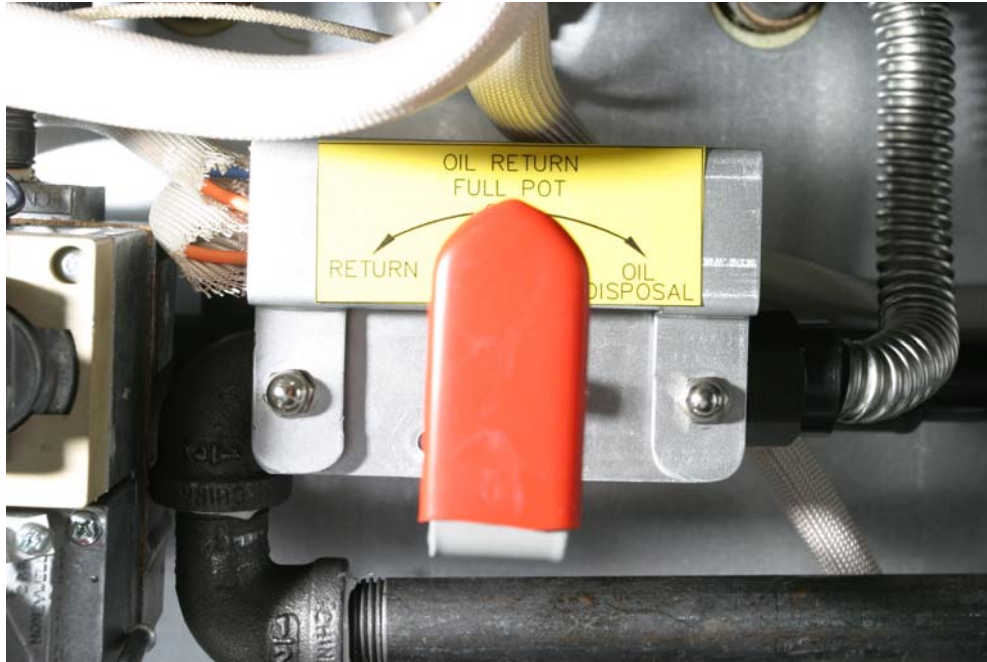

Turn the handle to the left to return oil from the filter pan to the frypot.
Turn it to the right to discharge the oil to the disposal system.

1. Ensure the filter pan is clean and prepared for filtration. Prepare the filter pan if necessary. **DO NOT** discharge oil through a dirty or incomplete filter pan.
2. With the oil at operating temperature, turn the fryer off. Wear protective clothing and use caution. Hot oil can cause serious injuries.
3. Drain the oil into the filter pan by opening the drain valve. **Drain only one vat at a time.** Close the drain valve. Ensure all drain valves are closed.
4. Ensure the oil disposal reservoir is not full and the fryer is properly connected to the oil disposal system.
5. Rotate the filter valve handle to the Oil Disposal position. See illustration above. The oil will be pumped from the filter pan to the oil disposal reservoir. Do not discharge water or other liquids through the filter system.
6. Return the filter handle to the upright OFF position when the filter pan empties.
7. Repeat steps for other fry vats as necessary.
8. Refill fryer with fresh oil.

PERFORMANCE SERIES GAS FRYERS MODELS MJ40 & MJ50

CHAPTER 5: PREVENTATIVE MAINTENANCE

5.1 Fryer Preventive Maintenance Checks and Services

DAILY CHECKS AND SERVICES

Inspect Fryer and Accessories for Damage

Look for loose or frayed wires and cords, leaks, foreign material in frypot or inside cabinet, and any other indications that the fryer and accessories are not ready and safe for operation.

Inspect the ceramic burner targets. Ensure the targets are in position above each orifice, and that the flame ignites approximately 2-½ inches (60 mm) above the orifice. The flame should strike the center of the target and be a rich blue color. Call your Factory Authorized Servicer (FAS) if you see any problems.

Clean Fryer Cabinet Inside and Out

 **DANGER**

Never attempt to clean the fryer during the cooking process or when the frypot is filled with hot oil/shortening. If water comes in contact with oil/shortening heated to cooking temperature, it can cause spattering, which can result in severe burns to nearby personnel.

 **WARNING**

Use a commercial-grade cleaner formulated to effectively clean and sanitize food-contact surfaces. Read the directions for use and precautionary statements before use. Particular attention must be paid to the concentration of cleaner and the length of time the cleaner remains on the food-contact surfaces.

Clean inside the fryer cabinet with dry, clean cloth. Wipe all accessible metal surfaces and components to remove accumulations of oil or shortening and dust.

Clean the outside of the fryer cabinet with a clean, damp cloth soaked with dishwashing detergent, removing oil/shortening, dust, and lint from the fryer cabinet.





Filter Cooking Oil/Shortening

The cooking oil/shortening used in your fryer should be filtered at least once every day (more often if the fryer is in constant use). Refer to Chapter 4, Filtration Instructions, for details.

WEEKLY CHECKS AND SERVICES

Check Recovery Time (Fryers with Controllers Only)

Recovery Time is the amount of time it takes the fryer to increase the frypot temperature from 250°F (121°C) to 300°F (149°C). It is a measure of the fryer's efficiency, and should be no more than 2 minutes and 30 seconds for MJ40 and MJ50 model fryers. The recovery time on models having CM III.5 controllers is automatically measured by the controller.

To view the recovery time on models equipped with CM III.5 controllers, press the Program Mode switch . **Code** will appear in the left display. Enter the code number     (1652) on the number keys. The latest recovery time will appear in both displays for 5 seconds.

QUARTERLY CHECKS AND SERVICES

Drain and Clean Frypot

During normal usage of your fryer, a deposit of carbonized cooking oil or shortening will gradually form on the inside of the frypot. This deposit must be periodically removed to maintain your fryer's efficiency.



DANGER

Allow oil/shortening to cool to 100°F (38°C) or lower before draining to an appropriate container for disposal.

If your fryer is not equipped with the built-in filtration system, the cooking oil or shortening must be drained into another suitable container. For safe, convenient draining and disposal of used cooking oil or shortening, Frymaster recommends the use of our shortening disposal unit (SDU). The SDU is available through your local distributor.

Clean Detachable Parts and Accessories

As with the frypot, a deposit of carbonized oil/shortening will accumulate on detachable parts and accessories such as baskets, sediment trays, or fishplates

Wipe all detachable parts and accessories with a clean cloth dampened with a detergent solution. Rinse and thoroughly dry each part.

Check Calibration of Thermostat Controller Temperature Control Knob

1. Ensure frypot is filled with cooking oil or melted shortening.
2. Set the temperature control knob to frying temperature.
3. Let the burner cycle on and off automatically three times in order for the cooking oil/shortening temperature to become uniform. If necessary, stir to get all shortening in the bottom of the frypot melted.

4. Insert a good-grade thermometer or pyrometer probe into the oil/shortening, with the end touching the fryer temperature probe.
5. When the burner starts for the fourth time, the thermometer/pyrometer reading should be within $\pm 5^{\circ}\text{F}$ (2°C) of the temperature knob setting. If not, calibrate as follows:
 - a. Loosen the setscrew in the temperature control knob until the knob rotates freely on the shaft.
 - b. Rotate the knob until the index line on the knob is aligned with the marking that corresponds to the thermometer or pyrometer reading.
 - c. Hold the knob and tighten the setscrew.
 - d. Recheck the thermometer/pyrometer reading against the temperature control knob setting the next time the burner comes on.
 - e. Repeat steps 5.a. through 5.d. until the thermometer/pyrometer reading and knob setting are within $\pm 5^{\circ}\text{F}$ (2°C).

If calibration is not possible, contact a Factory Authorized Servicer for service.

Check Thermostat Controller Thermostat Calibration

(NOTE: This check applies only to units equipped with Thermostat Controllers)

1. Ensure frypot is filled with cooking oil or shortening.
2. Set the temperature control knob to 325°F (162°C) and insert a good grade thermometer or pyrometer into the frypot so that it touches the temperature probe guard.
3. When the burner cycles off, set the temperature control knob to 340°F (170°C). As the reading on the thermometer or pyrometer nears the control knob setting, but before the burner cycles off, reset the knob to 325°F (162°C). Just as the reading on the thermometer or pyrometer drops below 325°F (162°C), the burner should cycle on. If it does not, calibration is required. Contact a Factory Authorized Servicer (FAS) for service.

Check Computer Magic III.5 Set Point Accuracy

(NOTE: This check applies only to units equipped with Computer Magic III.5 Controllers.)

1. Insert a good-grade thermometer or pyrometer into the oil/shortening, with the end touching the fryer temperature probe.
2. When the computer displays – – – – with no red dot between the first and second dashes (indicating that the frypot contents are within the cooking range), press the  switch once to display the temperature of the cooking oil or shortening as sensed by the temperature probe.

3. Press the  switch twice to display the set point.
4. Note the temperature on the thermometer or pyrometer. All three readings should be within $\pm 5^{\circ}\text{F}$ (2°C) of each other. If not, contact a Factory Authorized Servicer for assistance.

Clean Gas Valve Vent Tube

1. Carefully unscrew the vent tube from the valve. (**NOTE:** The vent tube may be straightened for easier removal.)
2. Pass a piece of ordinary binding wire (.052 inch diameter) through the tube to remove any obstruction.
3. Remove the wire and blow through the tube to ensure it is clear.
4. Reinstall tube and bend it so that the opening is pointing downward.

SEMI-ANNUAL CHECKS AND SERVICES

Check Burner Manifold Pressure



This task should be performed by qualified service personnel only. Contact FAS to arrange this service.



Do not run water or boil-out solution through the filtration system. Doing so will cause irreparable damage to the pump, and the warranty will be voided.

5.2 Built-In Filtration System Preventive Maintenance Checks and Services

There are no periodic preventive maintenance checks and services required for your Built-in Filtration System other than daily cleaning of the filter pan, screen, and hold-down ring with a solution of hot water and detergent. **Always remove the filter pan assembly from the fryer before cleaning with hot water and detergent. After rinsing, turn the filter pan upside down and slightly elevate the end to allow all water to drain from the suction tube. Ensure the pan is dried thoroughly before returning to service.**

If you notice that the system is pumping slowly or not at all, verify that the filter pan screen is on the bottom of the filter pan, with the paper on top of the screen. If the filter screen and paper are correctly installed, change the filter paper and verify that the O-rings on the connection fitting are present and in good condition. **NOTE:** With fresh paper and properly installed O-rings, the system should refill the fryer in 2 to 3 minutes.

5.3 ANNUAL/PERIODIC SYSTEM INSPECTION

This appliance should be inspected and adjusted periodically by qualified service personnel as part of a regular kitchen maintenance program.

Frymaster recommends that this appliance be inspected at least annually by a Factory Authorized Servicer as follows:

Fryer

- Inspect the cabinet inside and out, front and rear for excessive oil build-up and/or oil migration.
- Verify that the flue opening is not obstructed by debris or accumulations of solidified oil or shortening.
- Verify that burners and associated components (i.e. gas valves, pilot assemblies, ignitors, etc.) are in good condition and functioning properly. Inspect all gas connections for leaks and verify that all connections are properly tightened.
- Verify that the burner manifold pressure is in accordance with that specified on the appliance's rating plate.
- Verify that the temperature and high-limit probes are properly connected, tightened and functioning properly, and that probe guards are present and properly installed.
- Verify that component box components (i.e. controller, transformers, relays, interface boards, etc.) are in good condition and free from oil migration build-up and other debris. Inspect the component box wiring and verify that connections are tight and that wiring is in good condition.
- Verify that all safety features (i.e. drain safety switches, reset switches, etc.) are present and functioning properly.
- Verify that the frypot is in good condition and free of leaks and that the frypot insulation is in serviceable condition. Verify that the frypot tube diffusers are present and in good condition (i.e. no visible deterioration or damage).
- Verify that wiring harnesses and connections are tight and in good condition.

Built-In Filtration System

- Inspect all oil-return and drain lines for leaks and verify that all connections are tight.
- Inspect the filter pan for leaks and cleanliness. If there is a large accumulation of crumbs in the crumb basket, advise the owner/operator that the crumb basket should be emptied into a fireproof container and cleaned daily.
- Verify that all O-rings and seals (including those on the on quick-disconnect fittings) are present and in good condition. Replace O-rings and seals if worn or damaged.

- Check filtration system integrity as follows:
 - With the filter pan empty, place each oil return handle, one at a time, in the ON position. Verify that the pump activates and that bubbles appear in the cooking oil/shortening of the associated frypot.
 - Close all oil return valves (i.e., place all oil return handles in the OFF position). Verify proper functioning of each oil return valve by activating the filter pump using the lever on one of the oil return handle microswitches. No air bubbles should be visible in any frypot.
 - Verify that the filter pan is properly prepared for filtering, then drain a frypot of oil heated to 350°F (177°C) into the filter pan and close the frypot drain valve. Place the oil return handle in the ON position. Allow all cooking oil/shortening to return to the frypot (indicated by bubbles in the cooking oil/shortening). Return the oil return handle to the OFF position. The frypot should have refilled in no more than 2 minutes and 30 seconds.

PERFORMANCE SERIES GAS FRYERS MODELS MJ40 & MJ50

CHAPTER 6: OPERATOR TROUBLESHOOTING

6.1 Introduction

This chapter provides an easy reference guide to the more common problems that may occur during the operation of your equipment. The troubleshooting guides in this chapter are intended to help you correct, or at least accurately diagnose, problems with your equipment. Although the chapter covers the most common problems reported, you may very well encounter a problem not covered. In such instances, the Frymaster Technical Service Department will make every effort to help you identify and resolve the problem. Also, the troubleshooting guides may not be applicable to certain models.

When troubleshooting a problem, always use a process of elimination starting with the simplest solution and working through to the most complex. Never overlook the obvious. Anyone can forget to plug a cord into a receptacle or put a piece of filter paper into a filter pan. Don't assume that you are exempt from such occurrences.

Most importantly, always try to establish a clear idea of why a problem has occurred. Part of your corrective action involves taking steps to ensure that it doesn't happen again. If a controller malfunctions because of a poor connection, check all other connections while you're at it. If a fuse continues to blow, find out why. Always keep in mind that failure of a small component may often be indicative of potential failure or incorrect functioning of a more important component or system.

If you are in doubt as to the proper action to take, do not hesitate to call the Frymaster Technical Service Department or your local Frymaster Factory Authorized Servicer for assistance.

If the power cord(s) need replaced call your local Frymaster Factory Authorized Servicer for assistance. The power cord(s) should only be replaced by a Frymaster Factory Authorized Servicer.

 **DANGER**

Hot cooking oil/shortening will cause severe burns. Never attempt to move this appliance when filled hot cooking oil/shortening or to transfer hot cooking oil/shortening from one container to another.

 **DANGER**

This equipment should be unplugged when servicing, except when electrical circuit tests are required. Use extreme care when performing such tests.

This appliance may have more than one electrical power supply connection point. Disconnect all power cords before servicing.

Inspection, testing, and repair or replacement of electrical components including power cord(s) should be performed by an authorized service agent only.

6.2 Troubleshooting Fryers with Solid State (Analog), Digital or CM III.5 Controllers

PROBLEM	PROBABLE CAUSES	CORRECTIVE ACTION
<p>Burner will not light.</p>	A. Pilot not lit.	A. Light pilot per instructions in Chapter 3 of this manual.
	B. Drain valve open.	B. Verify that drain valve is fully closed.
	C. No electrical power to unit.	C. Verify that unit is plugged in and that circuit breaker is not tripped.
	D. No gas being supplied to unit.	D. Verify that the gas line connections are properly connected, that any cutoff valves between the fryer and the gas main are open, and that the main gas cutoff valve is open.
	E. Failed controller.	E. If available, substitute controller known to be good for suspect controller. If fryer operates normally, order replacement controller from FAS.
<p>CM III.5 display shows <i>Pr ob.</i></p>	<p>Failed controller. Failed temperature probe.</p>	<p>If available, substitute controller known to be good for suspect controller. If fryer operates normally, order replacement controller from FAS. If the fryer doesn't operate properly, have the temperature probe circuit tested. Call FAS.</p>
<p>Unit stays in melt cycle continuously.</p>	<p>Failed controller. Failed temperature probe.</p>	<p>If available, substitute controller known to be good for suspect controller. If fryer operates normally, order replacement controller from FAS. If the fryer doesn't operate properly, have the temperature probe circuit tested. Call FAS.</p>

PROBLEM	PROBABLE CAUSES	CORRECTIVE ACTION
<p>CM III.5 will not go into programming mode.</p>	<p>A. Temporary controller malfunction caused by voltage surge.</p>	<p>A. Disconnect unit from electrical power, wait at least one minute, reconnect unit to the power supply and turn controller on.</p>
	<p>B. Failed controller.</p>	<p>B. If available, substitute controller known to be good for suspect controller (see Section 6.6). If fryer operates normally, order replacement controller from FAS.</p>
<p>CM III.5 displays H as it comes out of melt cycle</p> <p>OR</p> <p>Heating mode indicator does not come on at all.</p>	<p>A. Setpoint incorrect.</p>	<p>A. Verify that setpoint has been properly entered.</p>
	<p>B. Temporary controller malfunction caused by voltage surge.</p>	<p>B. Disconnect unit from electrical power, wait at least one minute, and reconnect unit to the power supply.</p>
	<p>C. Failed controller.</p>	<p>C. If available, substitute controller known to be good for suspect controller (see Section 6.6). If fryer operates normally, order replacement controller from FAS.</p>
<p>Heating mode indicator is on but fryer is not heating properly.</p>	<p>A. Burner is not lit.</p>	<p>A. Refer to <i>Burner will not light</i> problem on page 6-2.</p>
	<p>B. Failed controller.</p>	<p>B. If available, substitute controller known to be good for suspect controller (see Section 6.6). If fryer operates normally, order replacement controller from FAS.</p>

6.3 Troubleshooting Fryers with Thermostat Controls

PROBLEM	Probable Causes	Corrective Action
<p>Burner does not light.</p>	<p>A. Pilot is not lit.</p>	<p>A. Light pilot per instructions in Chapter 3 of this manual.</p>
	<p>B. Drain valve not fully closed.</p>	<p>B. Verify drain valve is fully closed.</p>
	<p>C. No electrical power to unit. (Other than millivolt units.)</p>	<p>C. Verify that unit is correctly plugged in and that circuit breaker is not tripped.</p>
	<p>D. No gas being supplied to unit.</p>	<p>D. Verify that the gas line connections are properly connected, that any cutoff valves between the fryer and the gas main are open, and that the main gas cutoff valve is open.</p>
<p>Fryer never reaches frying temperature.</p>	<p>Failed thermostat or thermostat out of calibration.</p>	<p>Isolating the problem requires additional troubleshooting beyond the scope of operator troubleshooting. Call FAS.</p>

6.4 Troubleshooting the Built-In Filtration System

PROBLEM	PROBABLE CAUSES	CORRECTIVE ACTION
<p>Pump won't start.</p> <p style="text-align: center;">OR</p> <p>Pump stops during filtering.</p>	<p>A. Thermal overload switch has tripped on an overheated motor.</p> <p>Test: If the pump stopped suddenly during the filtering process, especially if after several filtering cycles, the pump motor has probably overheated. Place the filter handle in the OFF position, allow the pump to cool for at least 45 minutes, and then press the reset button on the pump motor. Attempt to activate the pump.</p>	<p>A. If the pump runs normally after resetting the thermal overload switch, the pump was overheated.</p> <p>Always filter with the cooking oil/shortening at or near frying temperature.</p> <p>Allow the pump motor to cool off for about 10 minutes after filtering two full frypots one after the other.</p> <p>Check the filter paper after each frypot is filtered. Replace the paper if there is a large accumulation of sediment.</p>
	<p>B. Failed filter handle microswitch.</p> <p>Test: If this is a multi-pot fryer, attempt to operate the pump using a different handle. If the pump starts, the handle microswitch is out of alignment or has failed.</p> <p>When the handle is placed in the ON position, the lever on the microswitch should be firmly pressed against the switch. If so, the switch has failed. If not, the switch is loose and/or misaligned.</p>	<p>B. If the switch is loose, tighten the screws holding it in place, ensuring that when the handle is placed in the ON position, the lever on the microswitch is pressed firmly against the switch.</p> <p>If the switch has failed, call FAS.</p>
	<p>C. Pump blockage.</p> <p>Test: Close the drain valve. Place the filter handle in the OFF position, allow the pump to cool for at least 45 minutes, and then press the reset button on the pump motor. Pull the filter pan from the unit and then activate the pump. If the pump motor hums and then stops, the pump is blocked.</p>	<p>C. Pump blockages are usually caused by sediment build-up in the pump due to improperly sized or installed filter paper and failure to use the crumb screen. Call FAS to have blockage cleared.</p> <p>Ensure that filter paper is of the proper size and is installed properly, and that the crumb screen is used.</p>

PROBLEM	PROBABLE CAUSES	CORRECTIVE ACTION
<p>Pump starts, but no transfer takes place or the transfer is very slow.</p>	<p>A. Cooking oil/shortening is too cold for filtering.</p>	<p>A. To properly filter, the oil or shortening should be at or near 350°F (177°C). At temperatures lower than this, the oil or shortening becomes too thick to pass through the filter medium easily, resulting in much slower oil return and eventual overheating of the filter pump motor. Ensure that the cooking oil or shortening is at or near frying temperature before draining into filter pan.</p>
	<p>B. Improperly installed or prepared filter pan components.</p> <p>Test: Close the drain valve. Move the filter handle to the OFF position, pull the filter pan from the unit. Move the filter handle to the ON position.</p> <p>If a strong stream of air is being pumped out of the oil return port, the problem is with the filter pan components.</p>	<p>B. Remove the oil from the filter pan and replace the filter paper, ensuring that the filter paper support screen is in place under the paper.</p> <p>If this does not correct the problem, the filter pan suction tube is probably blocked. Remove the blockage using a thin, flexible wire. If unable to remove the blockage, call FAS.</p>
	<p>C. Improperly installed or prepared filter pan components (cont.).</p>	<p>C. Verify that filter connection O-rings are present and in good condition.</p> <p>Replace the filter paper, ensuring that the filter paper support screen is properly positioned under the paper.</p>

6.5 Troubleshooting Abnormal Burner Operation

PROBLEM	PROBABLE CAUSES	CORRECTIVE ACTION
<p>Fryer is operating normally, but flames are rolling out of the front of the burner.</p>	<p>Obstructed gas valve vent tube.</p>	<p>Shut the fryer down and clean the gas valve vent tube in accordance the instructions on Page 5-4 – 5-5 of this manual.</p>
	<p>Obstruction or carbon build-up in the flue.</p>	<p>Shut the fryer down and remove any obstructions and/or accumulations of carbon in the flue.</p>



FRYMASTER
8700 LINE AVENUE, SHREVEPORT, LA 71106-6800

800-551-8633
318-865-1711

WWW.FRYMASTER.COM

EMAIL: FRYSERVICE@FRYMASTER.COM

©2025 Frymaster LLC. except where explicitly stated otherwise. All rights reserved. Continuing product improvement may necessitate change of specifications without notice.

Part Number FRY_IOM_8197397 04/2025

