

Frymaster®

ODC (Oil Disposal Caddy)

DO'S

Use only oil or shortening in the caddy.

Do clean inside the oil caddy.

Ensure at least two people lift the oil caddy when disposing.

DON'TS

Don't fill with water or use to drain boilout solution. Doing so will rust the caddy.

Don't overfill.

Don't move with the lid unlatched.

Don't leave oil in the ODC.

Don't allow shortening to solidify in the ODC.

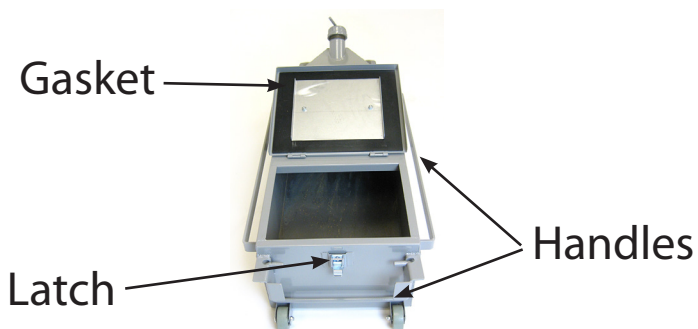
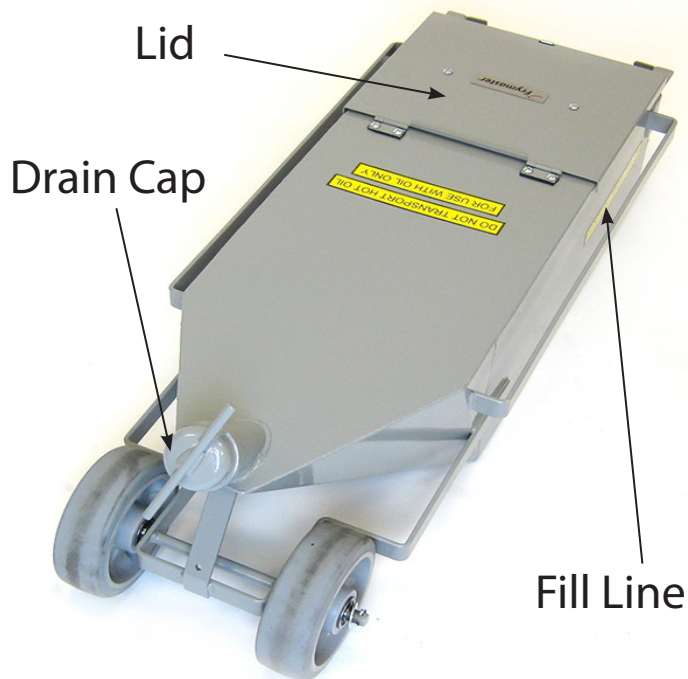

USING AN ODC

- Ensure the cap is hand tightened on the drain tube.
- Place the open tank under the drain valve or drain extension of a fryer.
- Ensure the fryer is off and the oil is no more than 100°F (38°C).
- Drain the oil into the ODC. Fill only to the fill line on the tank. Drain only one vat at a time.
- Close and secure the lid of the ODC.
- Roll it to the disposal site.
- Remove the cap.
- Unlatch the lid to allow airflow, but keep lid secured and covered.
- Use two people to lift and empty the ODC into the disposal vessel.

CAUTION:

- To minimize the chances for burns, always allow the oil to cool below 100°F (38°C) before draining or transporting to the disposal area.
- Always use PPE (safety gloves and splash shields) when using the ODC.
- Do **NOT** fill above marked fill line.
- Do **NOT** move without the lid securely clasped and the gasket in place.

Cleaning

Clean the exterior surfaces of the ODC with a soft cloth and a solution of detergent and water. It is not necessary to clean the interior of the reservoir, but if desired it may be wiped down with clean paper towels to remove excess residual shortening.

Service, Parts Ordering

A list of Frymaster Factory Authorized Servicers (FAS's) is located on the Frymaster website at <http://www.frymaster.com/service>

Refer to this list to find the agency nearest you. If you do not have access to this list, contact the Frymaster Technical Service Department at 1-800-551-8633 or 1-318-865-1711 or by e-mail: fryservice@welbilt.com.

Equipment Damaged in Shipment?

1. File a claim for damages immediately, regardless of the extent of damages.
2. Inspect for and record all damage and ensure that this information is noted on the freight bill or express receipt and is signed by the person making the delivery.
3. Concealed loss or damage that was unnoticed until the equipment was unpacked should be recorded and reported to the freight company or carrier immediately upon discovery. A concealed damage claim must be submitted within 5 days of the date of delivery. Ensure that the shipping container is retained for inspection.

FRYMASTER DOES NOT ASSUME RESPONSIBILITY FOR DAMAGE OR LOSS INCURRED IN TRANSIT.



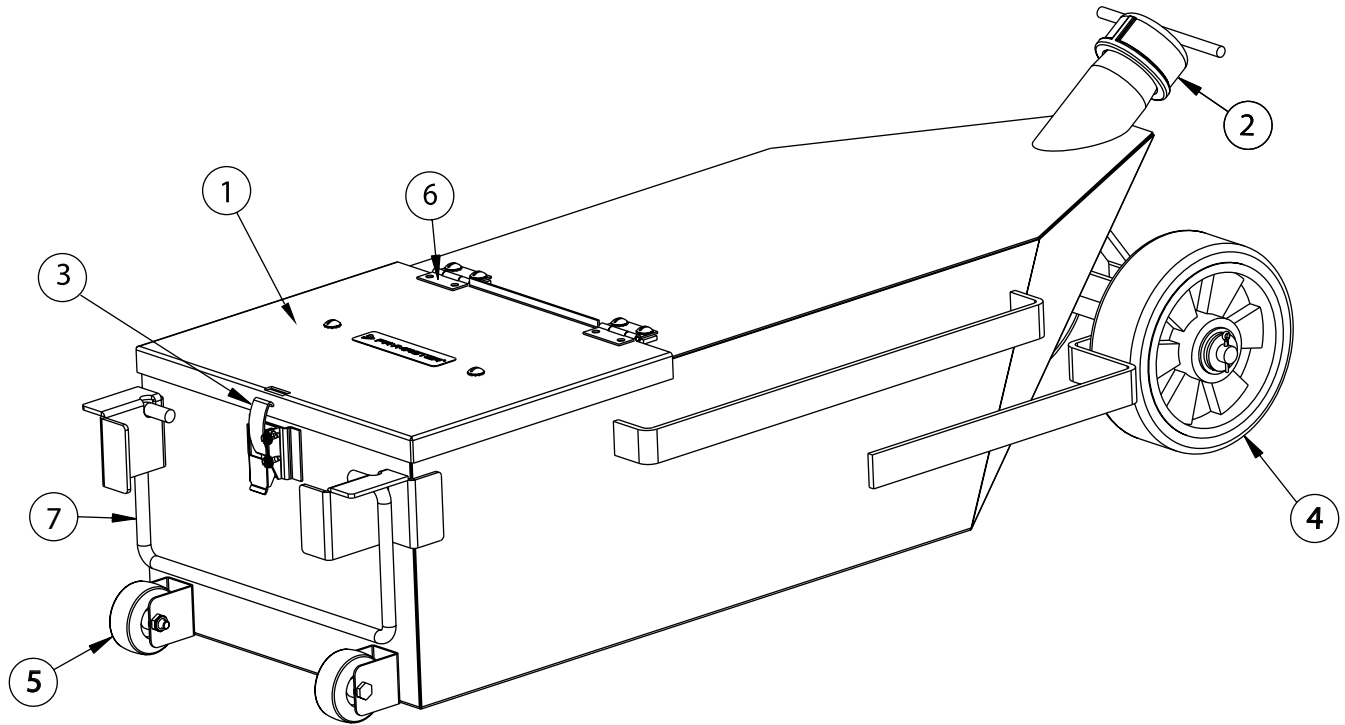

ITEM	PART NUMBER	DESCRIPTION
1	1086044	COVER ASSEMBLY, SDU 50 LBS
2	1087222	CAP ASSY, OIL DISPOSE CADDY DRAIN
3	8100742	LATCH, DRAW MSDUSO
4	8103784	WHEEL, 6"X2" FITS .S"AXLE
5	8104941	WHEEL, 2" GREY PLOYURETHANE
6	8100519	HINGE
7	8104698	HANDLE
*	8161023	GASKET, COVER SDU 50

*Not illustrated