



**Super Runner Series Electric  
SR114E**

**Super Runner Series Electric Fryers  
Installation & Operation Manual**

**DEAN<sup>®</sup>**

NON-CE &



Dean, a member of the Commercial Food Equipment Service Association, recommends using CFESA Certified Technicians.

**Service Hotline 1-318-865-1711**

Email: [fryservice@welbilt.com](mailto:fryservice@welbilt.com)  
[www.frymaster.com](http://www.frymaster.com)

02/2025



Please read all sections of this manual and retain for future reference.

**NOTICE**

IF, DURING THE WARRANTY PERIOD, THE CUSTOMER USES A PART FOR THIS FRYMASTER DEAN EQUIPMENT OTHER THAN AN UNMODIFIED NEW OR RECYCLED PART PURCHASED DIRECTLY FROM FRYMASTER DEAN, OR ANY OF ITS AUTHORIZED SERVICERS, AND/OR THE PART BEING USED IS MODIFIED FROM ITS ORIGINAL CONFIGURATION, THIS WARRANTY WILL BE VOID. FURTHER, FRYMASTER DEAN AND ITS AFFILIATES WILL NOT BE LIABLE FOR ANY CLAIMS, DAMAGES OR EXPENSES INCURRED BY THE CUSTOMER WHICH ARISE DIRECTLY OR INDIRECTLY, IN WHOLE OR IN PART, DUE TO THE INSTALLATION OF ANY MODIFIED PART AND/OR PART RECEIVED FROM AN UNAUTHORIZED SERVICER.

**NOTICE**

This appliance is intended for professional use only and is to be operated by qualified personnel only. A Frymaster Dean Factory Authorized Servicer (FAS) or other qualified professional should perform installation, maintenance, and repairs. Installation, maintenance, or repairs by unqualified personnel may void the manufacturer's warranty. See Chapter 1 of this manual for definitions of qualified personnel.

 **WARNING**

This appliance is not intended for use by children under the age of 16 or persons with reduced physical, sensory or mental capabilities, or lack of experience and knowledge, unless they have been given supervision concerning use of the appliance by a person responsible for their safety. Do not allow children to play with this appliance.

**NOTICE**

All fryers shipped without factory supplied cords and plug assemblies must be hardwired using flexible conduit to the terminal block located on the rear of the fryer. These fryers should be wired to NEC specifications. Hardwired units must include installation of restraint devices.

**NOTICE**

This equipment must be installed in accordance with the appropriate national and local codes of the country and/or region in which the appliance is installed.

**NOTICE**

Drawings and photos used in this manual are intended to illustrate operational, cleaning and technical procedures and may not conform to onsite management operational procedures.

 **DANGER**

Improper installation, adjustment, maintenance or service, and unauthorized alterations or modifications can cause property damage, injury, or death. Read the installation, operating and service instructions thoroughly before installing or servicing this equipment

 **DANGER**

The front ledge of the fryer is not a step. Do not stand on the fryer. Serious injury can result from slips or contact with the hot oil.

**⚠ DANGER**

Single fryers equipped with legs must be stabilized by installing anchor straps. All fryers equipped with casters must be stabilized by installing restraining chains

**⚠ DANGER**

Do not store or use gasoline or other flammable vapors and liquids in the vicinity of this or any other appliance.

**⚠ DANGER**

This appliance must be connected to a power supply having the same voltage and phase as specified on the rating plate located on the inside of the appliance door.

**⚠ WARNING**

Use caution and wear appropriate safety equipment to avoid contact with hot oil or surfaces that may cause severe burns or injury.

**⚠ WARNING**

No structural material on the fryer should be altered or removed to accommodate placement of the fryer under a hood. Questions? Call the Frymaster Dean Service Hotline at 1-800-551-8633.

**⚠ DANGER**

Adequate means must be provided to limit the movement of this appliance without depending on or transmitting stress to the electrical conduit. A restraint kit is provided with the fryer. If the restraint kit is missing contact your local Frymaster Factory Authorized Servicer (FAS) for part number 826-0900.

**⚠ DANGER**

Do not spray aerosols in the vicinity of this appliance while it is in operation.

**⚠ WARNING**

Do not use water jets to clean this equipment.

# SUPER RUNNER SERIES ELECTRIC FRYERS

## CHAPTER 1: INSTALLATION INSTRUCTIONS

### 1.1 Safety Information

Before attempting to operate your unit, read the instructions in this manual thoroughly. Throughout this manual you will find notations enclosed in double-bordered boxes with the symbol . The information contained in the box concerns actions or conditions that may cause or result in injury to personnel or damage to your system, and/or cause your system to malfunction.

### 1.2 General Installation Instructions

#### NOTICE

**This appliance is only for professional use and shall be used by qualified personnel only.**

#### NOTICE

**If this equipment is wired directly into the electrical power supply, a means for disconnection from the supply having a contact separation of at least 3-mm in all poles must be incorporated in the fixed wiring.**

#### NOTICE

**This equipment must be positioned so that the plug is accessible unless other means for disconnection from the power supply (e.g., a circuit breaker) is provided.**

#### NOTICE

**If this appliance is permanently connected to fixed wiring, it must be connected by means of copper wires having a temperature rating of not less than 194°F (90°C).**

#### NOTICE

**If the electrical power supply cord is damaged, it must be replaced by a Frymaster Dean Factory Authorized Servicer or a similarly qualified person in order to avoid a hazard.**

#### DANGER

**This appliance must be connected to a power supply having the same voltage and phase as specified on the rating plate located on the inside of the appliance door.**

#### DANGER

**All wiring connections for this appliance must be made in accordance with the wiring diagram(s) furnished with the appliance. Refer to the wiring diagram(s) affixed to the inside of the appliance door when installing or servicing this equipment.**

#### DANGER

**Frymaster Dean appliances equipped with legs are for stationary installations. Appliances fitted with legs must be lifted during movement to avoid damage to the appliance and bodily injury. For movable installations, optional equipment casters must be used. Questions? Call 1-800-551-8633.**

#### DANGER

**Single fryers must be restrained to prevent tipping when installed in order to avoid the splashing of hot liquid. The means of restraint may be the manner of installation, such as connection to battery of appliances or installing the fryer in an alcove, or by separate means, such as straps or chains.**

#### DANGER

**Do not attach an apron drainboard to a single unit. The appliance may become unstable, tip over, and cause injury. The appliance area must be free and clear of combustible material at all times.**

# SUPER RUNNER SERIES ELECTRIC FRYERS

## CHAPTER 1: INSTALLATION INSTRUCTIONS

### CLEARANCE AND VENTILATION

This fryer must be installed with a 6-inch (150-mm) clearance at both sides and back when installed adjacent to combustible construction. No clearance is required when installed adjacent to non-combustible construction. A minimum of 24-inches (600-mm) clearance should be provided at the front of the fryer.

### INSTALLATION

For units equipped with legs: Lift the unit and move it into its final position. Do not drag or push the fryer into position. Doing so may damage the legs. Level the unit front to back and side to side. If the fryer is not level, the unit will not function efficiently.

- A. Adjust leg height with an adjustable or 1-1/16-inch (27-mm) open-end wrench by turning the hexagon-shaped foot on the bottom of the leg. **NOTE:** The foot is for minor leg height adjustment only. **Do not adjust outward more than 3/4-inch (19-mm).**
- B. When leveling the unit, the leg body should be held firmly to keep the leg from bending or rotating while turning the foot to the required height.

For units equipped with casters: Roll the unit into its final position and lock the front casters.

When the fryer is leveled in its final position, install the restraints provided with the unit to limit its movement so that it does not depend on or transmit stress to the electrical conduit or connection. Install the restraints in accordance with the provided instructions (see illustration below). If the restraints are disconnected for service or other reasons, they must be reconnected before the fryer is used.

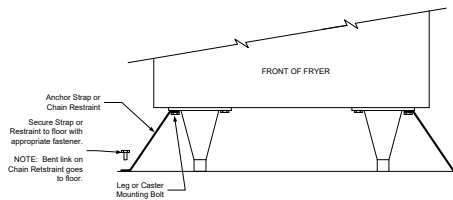

### 1.3 Receiving and Unpacking Equipment

- A. Check that the container is upright. Use an outward prying motion - **no hammering** - to remove the carton. Unpack the fryer carefully and remove all accessories from the carton. Do not discard or misplace these, as they will be needed.
- B. After unpacking, immediately check the equipment for visible signs of shipping damage. If damage has occurred, contact the carrier and file the appropriate freight claims. Do not contact the factory. Shipping damage responsibility is between the carrier and the dealer.

#### If your equipment arrives damaged:

1. File claim for damages immediately, regardless of extent of damage.
2. Visible loss or damage: Be sure this is noted on the freight bill or express receipt and is signed by the person making the delivery.
3. Concealed loss or damage: If damage is unnoticed until equipment is unpacked, notify freight company or carrier immediately, and file a concealed damage claim. This should be done within 5 days of date of delivery. Be sure to retain container and all packing materials for inspection.

**NOTE: Dean Does Not Assume Responsibility for Damage or Loss Incurred in Transit.**

- C. **Frying systems with built-in filtration:** Take off the filter support brace and remove the filter pan from the cabinet.

# SUPER RUNNER SERIES ELECTRIC FRYERS

## CHAPTER 1: INSTALLATION INSTRUCTIONS

---

- D. **Decathlon four-battery systems:** Casters are pre-installed on the frying system and the carton is furnished with three unloading ramps. Remove the braces from the front casters by taking out the securing bolts. Carefully roll the unit down the ramps from the front (cooking side).
- E. Remove all plastic skin from sides, front, and doors of the fryer(s). Failure to do this prior to initial fryer operation will make it very difficult to remove later.

### 1.4 Power Requirements

Use copper wire ONLY suitable for at least 194°F (90°C)						
MODEL	VOLTAGE	PHASE	WIRE SERVICE	MINIMUM WIRE SIZE		AMPS (per leg)
				AWG	mm	
14 kW	208	Single	3	4	(5.83)	68
14 kW	208	3	3	8	(4.11)	39
14 kW	240	Single	3	4	(5.19)	59
14 kW	240	3	3	8	(3.26)	34
14 kW	230/400	3	4	6	(4.11)	21

 **DANGER**  
 The electrical power supply for this appliance **MUST** be the same as indicated on the rating and serial number plate located on the inside of the fryer door.

 **DANGER**  
 This appliance **MUST** be connected to the voltage and phase specified on the rating and serial number plate located inside the fryer door.

 **DANGER**  
 All wiring connections for this appliance **MUST** be made in accordance with the wiring diagrams furnished with the equipment. Wiring diagrams are located inside the fryer door.

# SUPER RUNNER SERIES ELECTRIC FRYERS

## CHAPTER 2: OPERATION

### 2.1 Initial Startup

Wash the unit and accessories thoroughly with hot, soapy water to remove any film residue, dust or debris. Rinse and wipe dry. Close the drain valve completely. Ensure the thermostat and high-limit thermostat sensing bulbs inside the frypot are securely seated in the holding clamp and that the clamp screws are secure (see photo at right).

Thermostat  
Probe

High-Limit



### Setup

#### WARNING

Fill the frypot to the bottom OIL LEVEL line with vegetable oil or shortening before pressing the ON/OFF switch to the "ON" position. Failure to do so could damage the frypot and/or the heating elements.

#### WARNING

**NEVER** set a complete block of solid shortening on top of heating elements. To do so will damage the elements and increase the potential for flash-point shortening temperatures and subsequent fire.

1. Fill the frypot with vegetable oil to the bottom OIL LEVEL line located on the rear of the frypot. This will allow for oil expansion as heat is applied. Do not fill cold oil any higher than the bottom line; overflow may occur as heat expands the oil. If solid shortening is used, carefully pack solid shortening into the bottom of the frypot, below, between and around the elements. Use extreme care not to damage the elements or sensing bulbs when packing the shortening into the frypot. Ensure the elements are completely covered with shortening prior to engaging power switch. **Never** insert a solid block of shortening into frypot on top of the elements. Hot spots and element damage will occur, and the potential for flash-fire increases.
2. Ensure that the power cord is plugged into the appropriate receptacle. Verify that the face of the plug is flush with the outlet plate, with no portion of the prongs visible.
3. Set the thermostat dial to the desired temperature. Ensure that the power is switched on. The fryer will automatically enter the melt cycle mode until the fryer temperature reaches 180°F (82°C). Allow the oil to come to operating temperature before starting a cook. If the fryer temperature exceeds 435°F (218°C) [410°F (210°C)], the over-temperature protection circuit will trip. Allow the fryer to remain off for 30 minutes before resetting the high-limit switch. Contact a service agent if the problem persists.

High-Limit  
Reset



Thermostat  
Control

4. Ensure that the oil/shortening level is at the *top* OIL LEVEL line when the fryer reaches operating. It may be necessary to add oil or shortening to bring the level up to the proper mark. If solid shortening is used, it may be necessary to turn the power switch off, and then back on, as the shortening melts, to prevent hot spots.

# SUPER RUNNER SERIES ELECTRIC FRYERS

## CHAPTER 2: OPERATION

---

### **Shutdown**

1. Press the ON/OFF switch to the "OFF" position.
2. Filter oil or shortening and clean the fryer.
3. Place the frypot covers on frypots.

### **2.2 Daily Operation**

1. Do not allow grease to accumulate or harden on the frame or body of the fryer. Clean the fryer inside and out with a solution of detergent and hot water daily.
2. Filter the cooking oil by draining the frypot through a filter cone at least daily. After the oil has been drained from the frypot, remove any residue from the pot, using a scraper if necessary. Use care not to damage the elements or sensor bulbs when removing residue from the frypot.
3. Clean the frypot at least once each week by filling it to just below the upper oil level mark with water. Add one cup of detergent and bring the solution to a boil. Allow the solution to simmer for 10-15 minutes, then drain and rinse the frypot with clean water twice. Add ¼ cup of white vinegar to the last rinse to neutralize any alkalinity remaining from the detergent. Wipe the frypot surfaces with a dry towel before refilling with cooking oil. If the fryer is not to be used immediately after cleaning, it is suggested that the inside of the frypot be wiped down with a light coat of cooking oil to prevent rust.

### **2.3 Recommended Spare Parts**

<b>DESCRIPTION</b>	<b>PART #</b>
Temperature Probe	826-2222
High-Limit Thermostat	807-3559
High-Limit Thermostat CE	807-3560
Transformer (208/222/230/240)	807-5129
Relay (12VDC)	807-1683
Element, 208V	807-4031
Element, 240V	807-4072
Element, 230V	807-4340
Light, Heat Indicator- White	807-1525
Light, Power Indicator - Green	807-4112
Leg, 6-inch	810-2053
Caster, 5-inch w/o Brake	810-0356
Caster, 5-inch w/Brake	810-0357
Strap Restraint Kit (Leg-Equipped Units)	826-1095
Chain Restraint Kit (Caster-Equipped Units)	826-0900



# SUPER RUNNER SERIES ELECTRIC FRYERS

## CHAPTER 3: PARTS AND WIRING DIAGRAMS

### 3.1 Wiring Diagram Single Phase

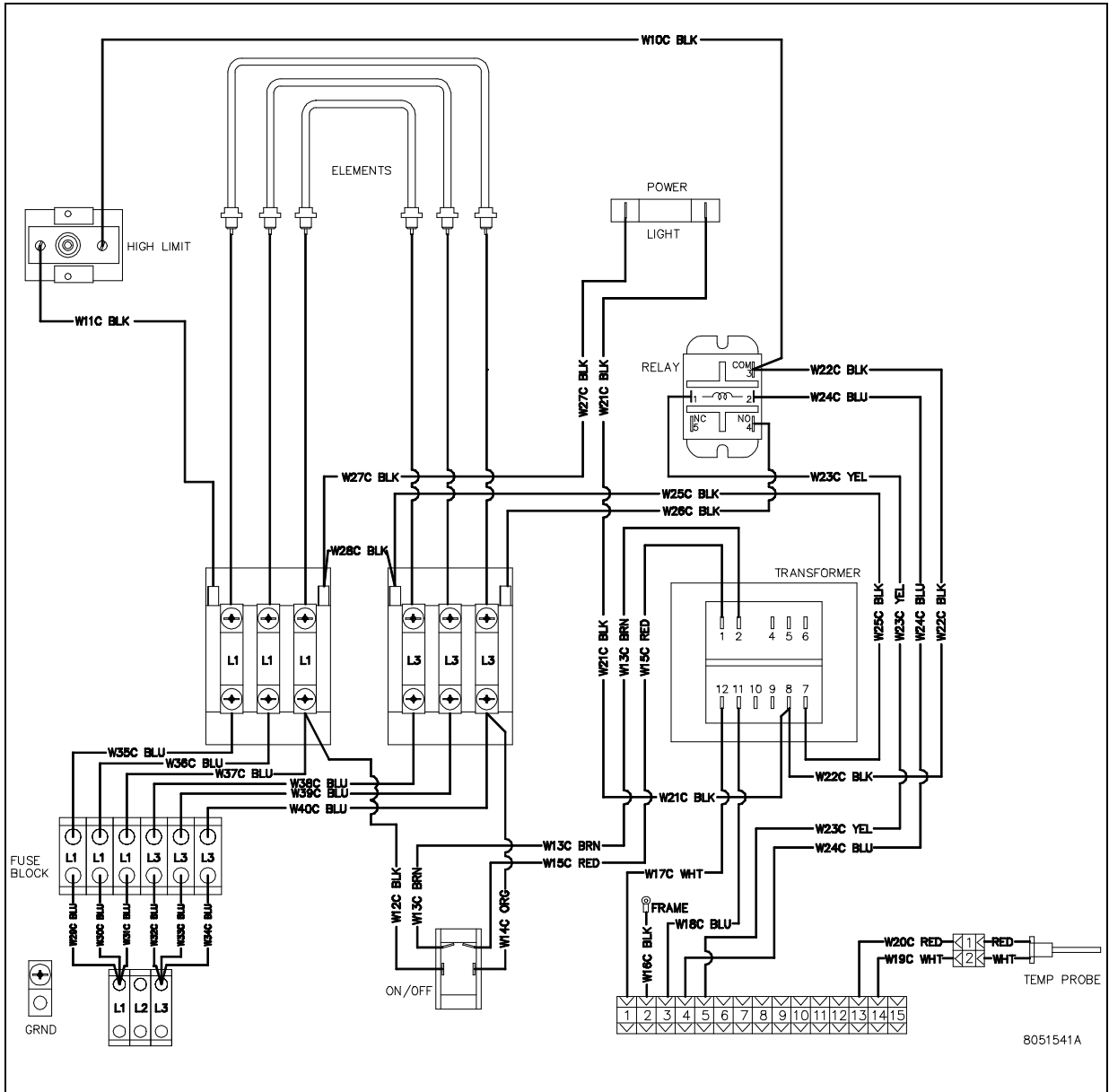

# SUPER RUNNER SERIES ELECTRIC FRYERS

## CHAPTER 3: PARTS AND WIRING DIAGRAMS

### 3.2 Wiring Diagram 3-Phase

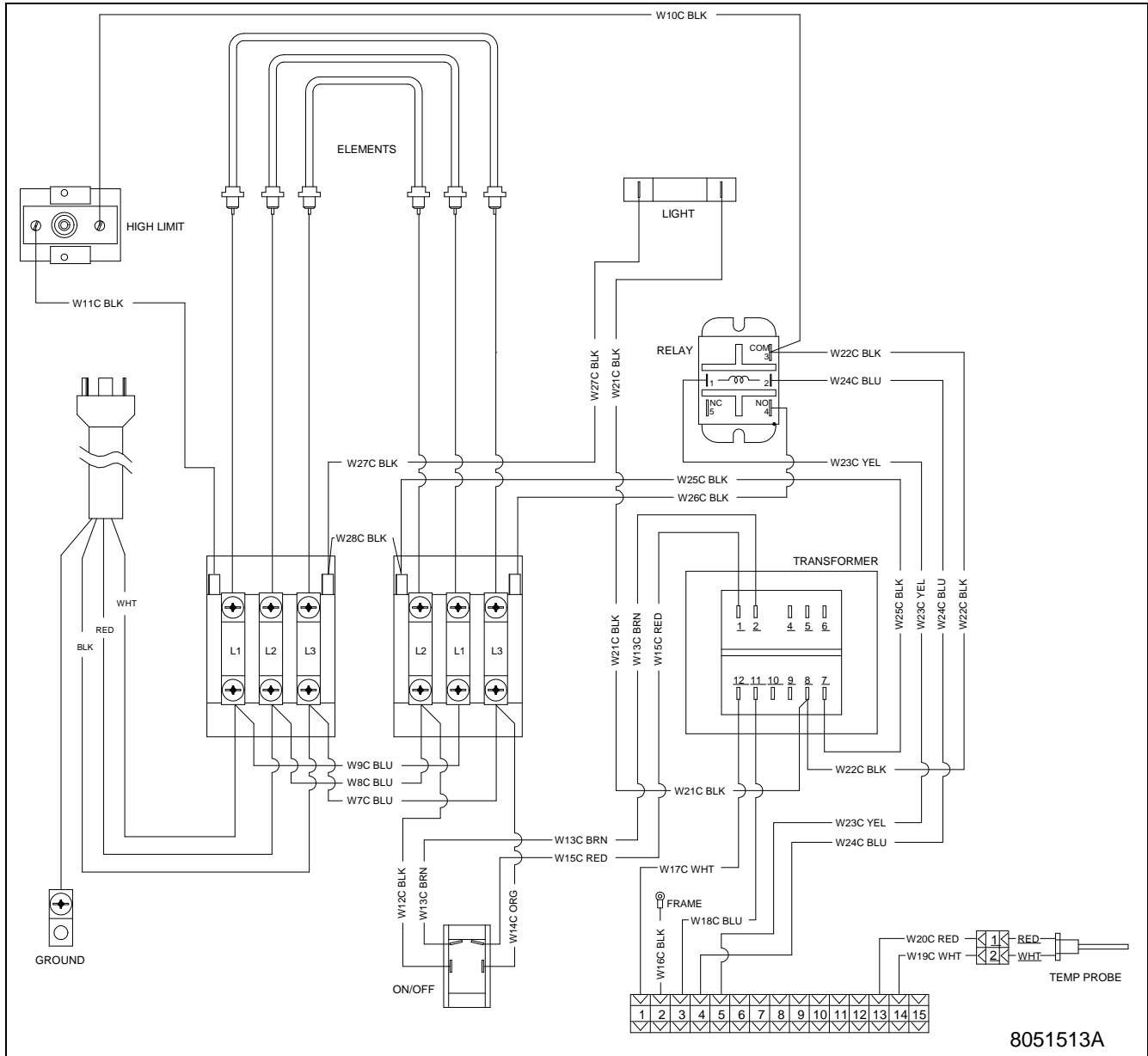

# SUPER RUNNER SERIES ELECTRIC FRYERS

## CHAPTER 3: PARTS AND WIRING DIAGRAMS

### 3.3 Wiring Diagram 3-Phase WYE

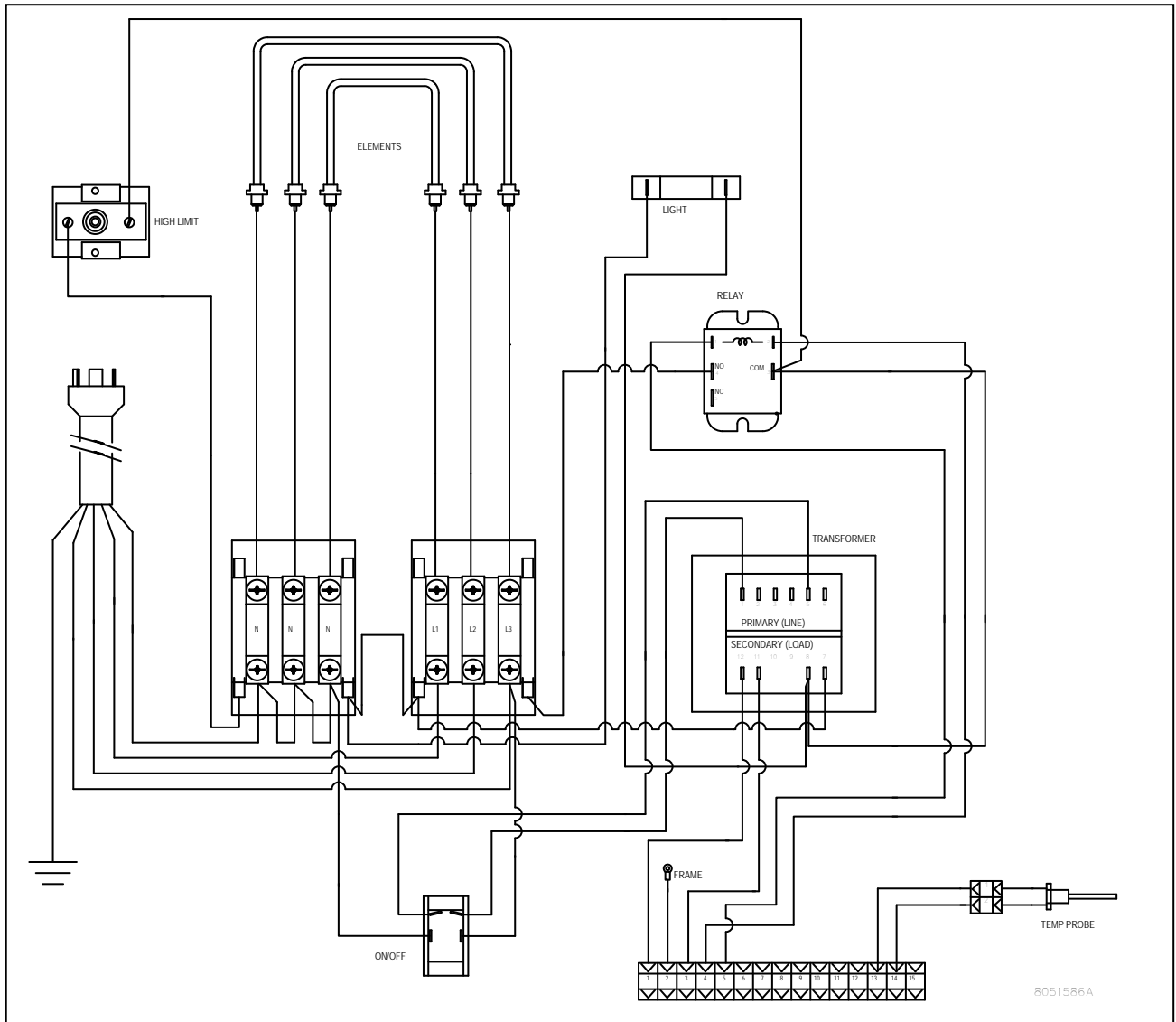

# DEAN®

Welbilt Foshan Foodservice Col, Ltd.  
No.12 Chuang Ye North Road, Song Gang Song Xia Industry Park  
Nanhai District, Foshan Guangdong, China 528234

---

800-551-8633  
318-865-1711

[WWW.FRYMASTER.COM](http://WWW.FRYMASTER.COM)

EMAIL: [FRYSERVICE@FRYMASTER.COM](mailto:FRYSERVICE@FRYMASTER.COM)

©2025 Frymaster LLC. except where explicitly stated otherwise. All rights reserved. Continuing product improvement may necessitate change of specifications without notice.

Part Number FRY\_IOM\_8197504F 02/2025

