

# *Frymaster*<sup>®</sup>

We Fit the Way You Fry<sup>™</sup>

## BIGLA30-T Series Gen III LOV<sup>™</sup> Gas Fryer

(Includes Gen IV fryers manufactured for Japan after 10/2018)



### Parts Manual

This manual is updated as new information and models are released. Visit our website for the latest manual.



Part Number: FRY\_P\_8197544 03/2025



**NOTICE**

IF, DURING THE WARRANTY PERIOD, THE CUSTOMER USES A PART FOR THIS FRYMASTER DEAN EQUIPMENT OTHER THAN AN UNMODIFIED NEW OR RECYCLED PART PURCHASED DIRECTLY FROM FRYMASTER DEAN, OR ANY OF ITS FACTORY AUTHORIZED SERVICERS, AND/OR THE PART BEING USED IS MODIFIED FROM ITS ORIGINAL CONFIGURATION, THIS WARRANTY WILL BE VOID. FURTHER, FRYMASTER DEAN AND ITS AFFILIATES WILL NOT BE LIABLE FOR ANY CLAIMS, DAMAGES OR EXPENSES INCURRED BY THE CUSTOMER WHICH ARISE DIRECTLY OR INDIRECTLY, IN WHOLE OR IN PART, DUE TO THE INSTALLATION OF ANY MODIFIED PART AND/OR PART RECEIVED FROM AN UNAUTHORIZED SERVICER.

**NOTICE**

This appliance is intended for professional use only and is to be operated by qualified personnel only. A Frymaster Authorized Servicer (FAS) or other qualified professional should perform installation, maintenance, and repairs. Installation, maintenance, or repairs by unqualified personnel may void the manufacturer's warranty.

# Table of Contents

---

## CHAPTER 1: Parts List

1.1	Accessories .....	1-1
1.2	Doors, Sides, Flue Caps, Cap-N-Splash, Top Caps, Flue Deflector and Casters.....	1-2
1.3	Control Panel Frame Assemblies.....	1-3
1.4	Drain System Components .....	1-4
1.5	Electronics and Electrical Components .....	1-5
1.5.1	Component Boxes and Associated Components .....	1-5
1.5.2	Transformer Boxes.....	1-6
1.5.3	FIB (Filter Interface Board) Auto Top Off/Filter Box Comp. <b>(prior to 06/2019)</b> .....	1-8
1.5.3.1	FIB (Filter Interface Board) Auto Top Off/Filter Box Comp. <b>(05/2019-06/2021)</b> .....	1-9
1.5.3.2	FIB (Filter Interface Board) Auto Top Off/Filter Box Comp. <b>(05/2019-06/2021)</b> .....	1-11
1.5.4	VIB (Valve Interface Board) Components .....	1-12
1.5.5	Power Reset Switch and USB Connector.....	1-12
1.6	Wiring.....	1-13
1.6.1	Wiring Harness Full Vat - SIB to Rear of Component Box.....	1-13
1.6.2	Wiring Harness Dual Vat - SIB to Rear of Component Box.....	1-14
1.6.3	Ignition Wiring Harness Full Vat – Control Box to Components .....	1-15
1.6.4	Ignition Wiring Harness Dual Vat – Control Box to Components .....	1-16
1.6.5	Wiring Harness Power .....	1-16
1.6.6	FIB Box Wiring Harness .....	1-17
1.6.7	Miscellaneous Wiring.....	1-17
1.7	Frypots and Associated Components.....	1-18
1.7.1	Full-Vat Frypot Components .....	1-18
1.7.2	Dual-Vat Frypot Components .....	1-20
1.7.3	Frypot Assemblies and Associated Parts.....	1-22
1.8	Oil Return Manifolds .....	1-23
1.9	Gas Supply and Combustion System Components .....	1-24
1.10	Gas Valves and Associated Components .....	1-26
1.11	Filtration System Components .....	1-28
1.11.1	Filter Motor Harnesses <b>(after 05/2019)</b> .....	1-30
1.12	ATO (Auto Top Off) Components.....	1-30
1.12.1	JIB Cradle, JIB Cap Assemblies .....	1-30
1.12.2	ATO Pump Assembly.....	1-31
1.12.3	Shortening Melting Unit.....	1-32
1.13	Bulk Oil System Components .....	1-33
1.13.1	Bulk Oil Dispose Waste Valve.....	1-33
1.13.2	Bulk Oil Manifold and Accessories.....	1-34
1.13.3	Japan Itto Can Dispose Components .....	1-36
1.14	Oil Quality Sensor (OQS) and Associated Parts .....	1-37
1.15	BIGLA30-T Series Simplified Wiring.....	1-38

# BIGLA30-T SERIES III LOV™ GAS FRYERS

## CHAPTER 1: PARTS LIST

### 1.1 Accessories

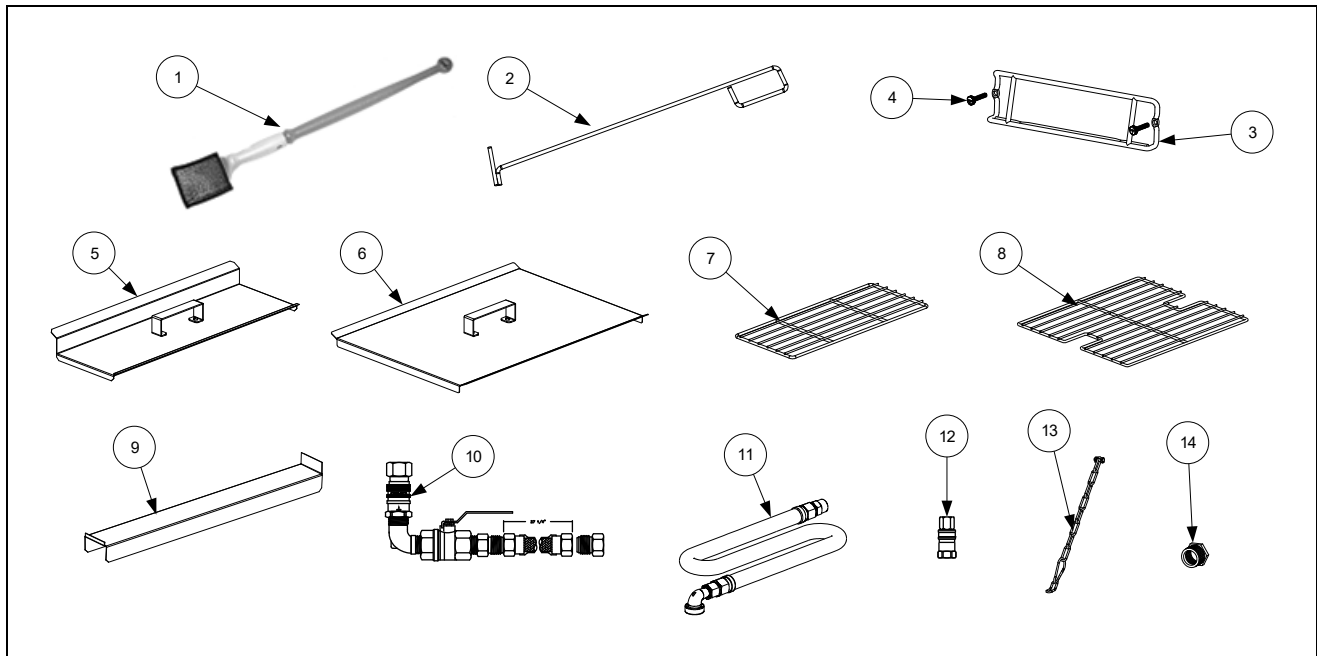

ITEM	PART #	COMPONENT
1	8030430	Brush, Frypot Ecolab
2	8030388	Fryers Friend LOV™
3	8102793	Hanger, Basket
	8104623	Hanger, Basket 2-Battery
	8104622	Hanger, Basket 3-Battery
4	8090171	Thumbscrew, ¼-20 X 1¾" Universal Hood ( <i>use 8090921 for Spacer</i> )
	8090402	Thumbscrew, ¼ -20 X ½" Cap-N-Splash Hood
5	8238898	Cover, Frypot, Dual Vat ( <b>Use 8239550 for Japan</b> )
6	8238897	Cover, Frypot, Full Vat
7	8030372	Basket Support Rack, Dual Vat
8	8030375	Basket Support Rack, Full Vat
*	8030136	Basket Support Screen, Full Vat (screen w/handle used in place of Item 8)
9	2600975	Connecting Strip, Frypot
10	8100478	Gas Line, 1" Dormont Flexible 27" w/Valve
11	8100088	36" Gas Line 1" Dormont Flexible
	8100085	48" Gas Line 1" Dormont Flexible
12	130001257	Quick-Disconnect Fitting, 1" Male & Female
	8103745	Quick Disconnect Fittings, ¾" set (includes male and female connectors)
13	8260900	Kit, Chain Restraint
14	8261045	Bushing, Flexible Gas Line (8130032)
*	8263283	Bracket, Locking Cabinet (used to lock into hoods)

\* Not illustrated.

## 1.2 Doors, Sides, Flue Caps, Cap-N-Splash, Top Caps and Casters

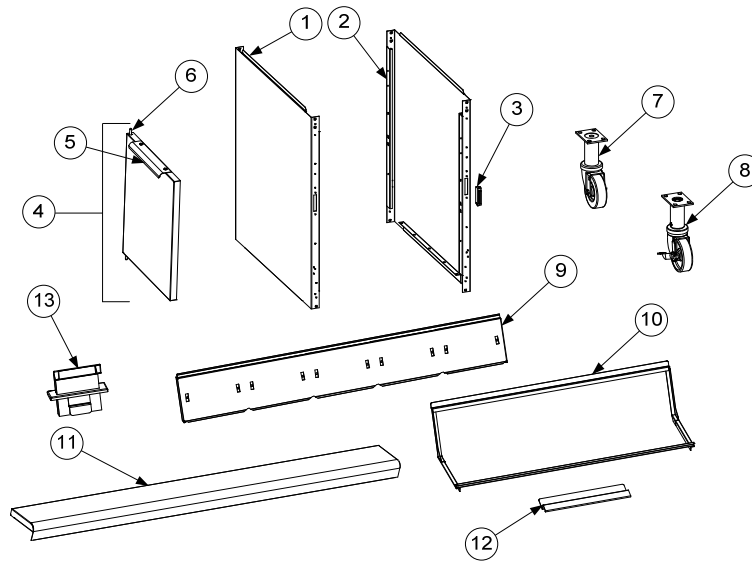

ITEM	PART #	COMPONENT
1	2611424	Side, Cabinet Left
2	2621424	Side, Cabinet Right
3	8101105	Magnet, Door (vertical) (use 8102346 for horizontal over filter pan)
4	1064397	Door, Left or Right (move handle to bottom for right) (use 1080915 for Door w/ Manual Holder)
5	2304960	Handle, Eurolook Door
6	1064067SP	Pin Assembly, Door
*	8100275	Spring, Door Pin
*	8090970	Retaining Ring
*	2307192	Hinge, Door Lower
*	2206097	Holder, Manual
7	8100327	Caster without Brake
8	8100944	Caster with Brake
9		Flue Cap-Stainless Steel
	8239517	Two Station ( <b>Use 2302635 for Hood Strip</b> )
	8239509	Three Station ( <b>Use 2302405 for Hood Strip</b> )
	8239518	Four Station ( <b>Use 2302636 for Hood Strip</b> )
	-	Five Station ( <b>Use 2302637 for Hood Strip</b> )
10		Cap-N-Splash Assemblies
	8239148	Two Station Fryer ( <b>Use 8239537 for Japan</b> )
	8239149	Three Station Fryer ( <b>Use 8239536 for Japan</b> )
	8239150	Four Station Fryer
	-	Five Station Fryer
11		Top Cap (Cap for 5-station fryer shown)
	1086158	Two Station Fryer
	1086159	Three Station Fryer
	1086160	Four Station Fryer
	1086161	Five Station Fryer
12	2601128	Guard, Cap/Splash Wave (Japan)
13	1086892	Flue Deflector (use 1088238 for 2 vat riser, 1088239 for 3 vat riser) (Japan)

\* Not illustrated.

### 1.3 Control Panel Frame Assemblies

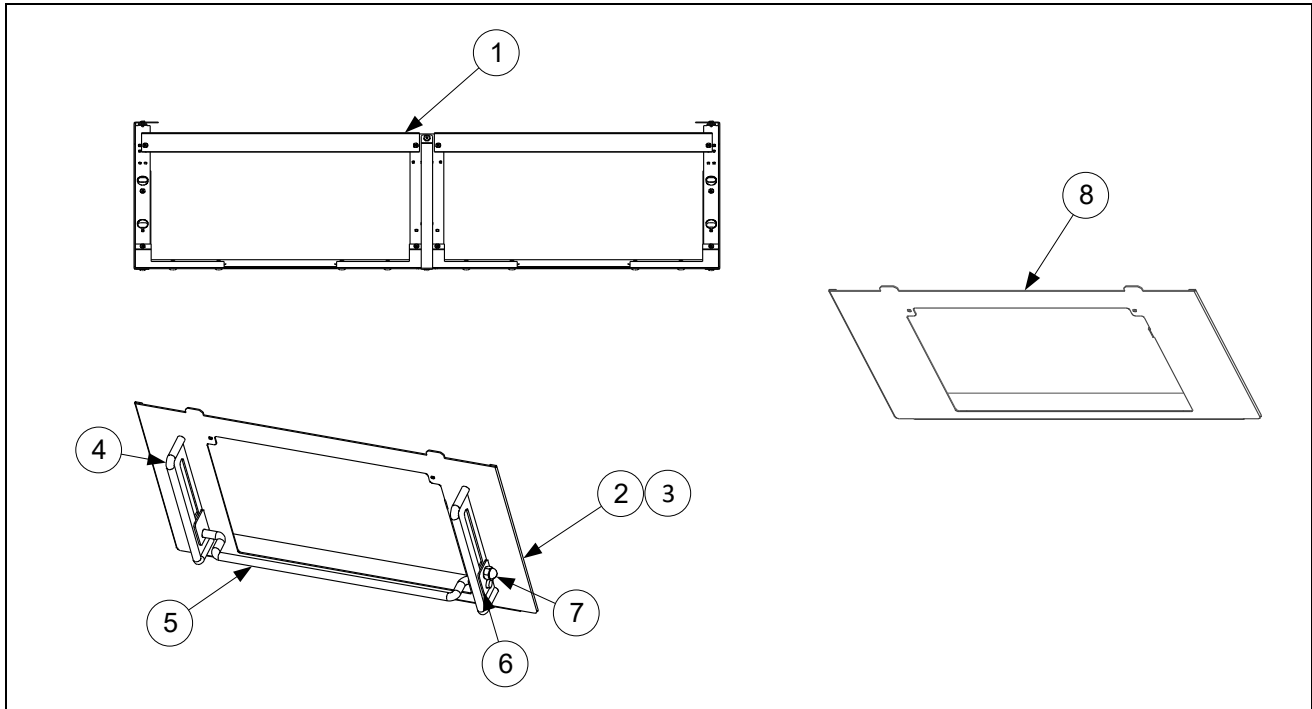

ITEM	PART #	COMPONENT
1	1088340	Frame Assembly, Control 2-Battery 10° <i>(after 05/2019)</i>
	1087710	Frame Assembly, Control 2-Battery <i>(prior to 06/2019)</i>
	1087711	Frame Assembly, Control 3-Battery <i>(prior to 06/2019)</i>
	1088362	Frame Assembly, Control 3-Battery 10° <i>(after 05/2019)</i>
	1087712	Frame Assembly, Control 4-Battery <i>(prior to 06/2019)</i>
	1088359	Frame Assembly, Control 4-Battery 10° <i>(after 05/2019)</i>
	1088360	Frame Assembly, Control 5-Battery 10° <i>(after 05/2019)</i>
2	1087744	Bezel Assembly, Control <i>(prior to 04/2022)</i>
3	2602083	Bezel, Single Touchscreen
4	8104898	Guide, Controller Adjustable Guard
5	8104899	Bar, Guard (Touch Screen Protection)
6	8104714	Plate, Outside Tightening
7	8090047	Nut, Cap ¼"-20
8	130000371	Bezel Assembly, Control FQ4000 <i>(after to 03/2022)</i>
*	8161204	Vent, UI Angled Spacer <i>(Use kit 8263618 for fryers without vent spacers)</i>

\* Not illustrated.

## 1.4 Drain System Components

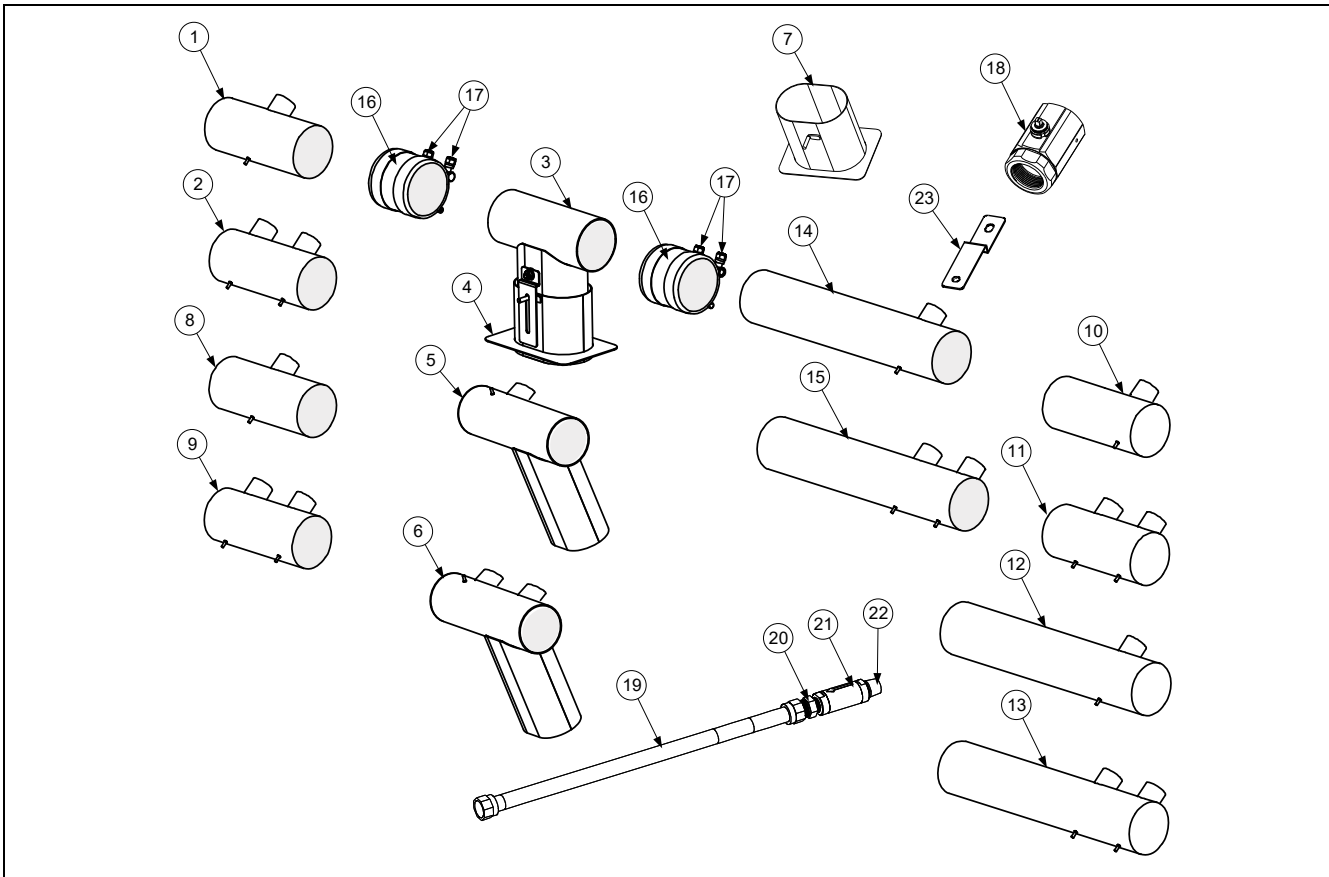

ITEM	PART #	COMPONENT
1	8237323	Drain Tube, Full-Vat Left Closed/Right End Open
2	8237325	Drain Tube, Dual-Vat Left Closed/Right End Open
3	1080887SP	Drain Tube, Dump ( <i>prior to 06/2019</i> )
	1088576SP	Drain Tube, Dump ( <i>after 05/2019</i> )
4	8237468	Shroud, Filter Pan Lid (attaches to item # 3) <b>Oval (2, 3, 4, 5 Vat After 10/2018)</b>
5	1081118SP	Drain Tube, Full-Vat 2 Bat. Dump Left Closed/Right End Open
6	1081120	Drain Tube, Dual-Vat 2 Bat. Dump Left Closed/Right End Open
7	8237480	Shroud, Filter Pan Lid 2 Bat. (attaches to item # 5 and 6) <b>Oval (2-Vat Prior to 10/2018)</b>
8	8237322	Drain Tube, Full-Vat Left and Right Open
9	8237324	Drain Tube, Dual-Vat Left and Right Open
10	8237330	Drain Tube, Full-Vat 2 Bat. Left Open/Right End Closed
11	8237331	Drain Tube, Dual-Vat 2 Bat. Left Open/Right End Closed
12	8237329	Drain Tube, Full-Vat Left Open/Right End Closed
13	8237326	Drain Tube, Dual-Vat Left Open/Right End Closed
14	8237328	Drain Tube, Full-Vat Left and Right Open
15	8237327	Drain Tube, Dual-Vat Left and Right Open
16	8160772	Sleeve
17	8090969	Clamp
*	8160630	Vinyl Cap
18	8104353	Valve, Drain 1¼" NPT
19	8101369	Flexline, ⅝" OD x 17.50"
20	8101668	Adaptor, Male ⅝" OD x ½"
21	8105084	Valve, Check 20 PSI
22	8130022	Nipple, ½" x Close NPT
23	2209518	Strap, Drain

\* Not illustrated.

## 1.5 Electronics and Electrical Components

### 1.5.1 Component Boxes and Associated Components

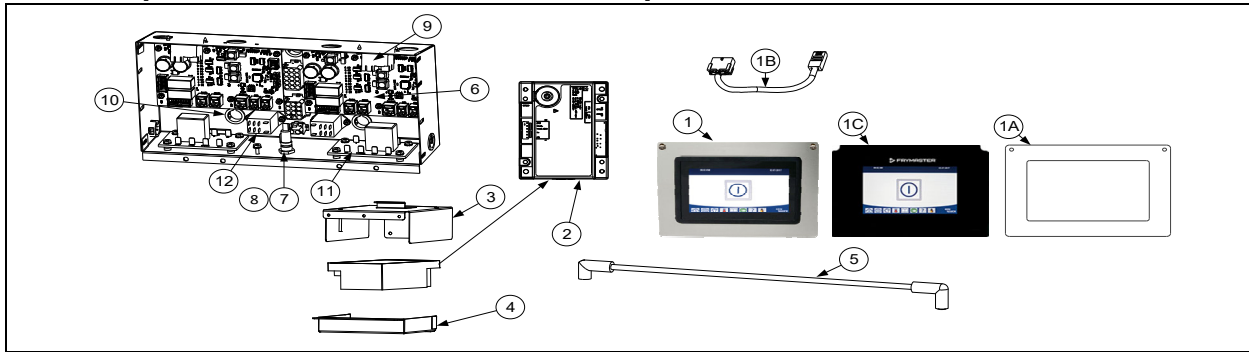

ITEM	PART #	COMPONENT
✓ 1	1089233SP	Controller, M4000 <b>USA, Canada (for fryers manufactured from 04/2022 to present)</b>
✓	1089237SP	Controller, M4000 <b>Intl CE GAS (for fryers manufactured from 04/2022 to present)</b>
✓	1089249SP	Controller, M4000 <b>Korea (for fryers manufactured from 04/2022 to present)</b>
✓	1089245SP	Controller, M4000 <b>Israel (for fryers manufactured from 04/2022 to present)</b>
✓	1089229SP	Controller, M4000 <b>Japan (for fryers manufactured from 04/2022 to present)</b>
1A	130000329	Bezel, Common UI ( <b>Metal Bezel only</b> )
1B	8076596	4000 Xfer Cable ( <b>Connects Common UI Controller to SIB Board</b> )
✓ 1C	1086730SP	Controller, M4000 <b>USA, Canada (for fryers manufactured prior to 04/2022)</b>
✓	1088437SP	Controller, M4000 <b>International CE (for fryers manufactured prior to 04/2022)</b>
✓	8263658	Controller, M4000 <b>Japan (for fryers manufactured prior to 04/2022)</b>
✓	1088467SP	Controller, M4000 <b>Israel (for fryers manufactured prior to 04/2022)</b>
✓	1088643SP	Controller, M4000 <b>Korea (for fryers manufactured prior to 04/2022)</b>
✓ 2	8075949	Module, Ignition Single Spark Fenwal
✓	8076382	Module, Ignition Single Spark Fenwal FV (Left) / DV Australia 3 sec
✓	8076383	Module, Ignition Single Spark Fenwal FV (Right) Australia 4 sec
✓		Harnesses, Ignition Module (rear of component box to components) ( <b>See Sections 1.6.3 &amp; 1.6.4</b> )
3	1088159	Plate, Assy Fenwal Module Mounting
4	8242482	Cover, Fenwal Ignition Module
✓ 5	8075614	Cable, Ignition 12"
✓ 6	1085979	Board, Interface SIB (Smart Interface Board)
✓ 7	8071321	Fuse Holder
✓ 8	8075570	Fuse 3.5A 250V
✓ 9	8071683	Relay, Blower 12VDC
10	8071926	Bushing, .875 Split
*	8075829	Speaker 4 ohm
✓ 11	8075731	Relay Board, 7-second Time Delay 100V ( <b>Japan</b> )
	8074812	Relay Board, 7-second Time Delay 120V ( <b>U.S., Canadian and Mexico units</b> )
	8074934	Relay Board, 7-second Time Delay 220V, 230V, 240V and 250V units ( <b>Intl units</b> )
✓ 12	8075623	Relay, 24VDC SPDT OIB (Oil Is Back) Sensor
✓ *	8104320	Lanyard, Controller Restraint
		<b>See Wiring Diagrams in BIGLA30-T Service Manual for cable locations</b>
*	8075553	Cable, P-Bus Left SIB (J9) to Right SIB (J9)
*	8075555	Cable, P-Bus w/ power Right SIB (J10) to VIB (Valve Interface Board) (J2)
*	8075551	Cable, C-Bus Right SIB (J7) to FIB (Filtration Interface Board) (J3)
*	8075549	Cable, C-Bus Right SIB (J7) to Right SIB (J8) (Connects component boxes together)
*	8076106	Adapter, RJ11 CAN SIB (J8) to Legacy 6-pin (MicroMate/Lock) CAN (OQS sensor to SIB 5")
✓ *	8074552	Terminator, CAN (ONLY used on OQS harness Y- adaptor)
✓ *	8075632	Terminator, CAN End Communication RJ11 (used in SIB J8 if OQS is <b>NOT</b> installed)
*	8076364	Harness, Wire SIB to Rear of Component Box Full Vat
*	8076365	Harness, Wire SIB to Rear of Component Box Dual Vat

\* Not illustrated. ✓ Recommended parts.



## 1.5.2 Transformer Boxes

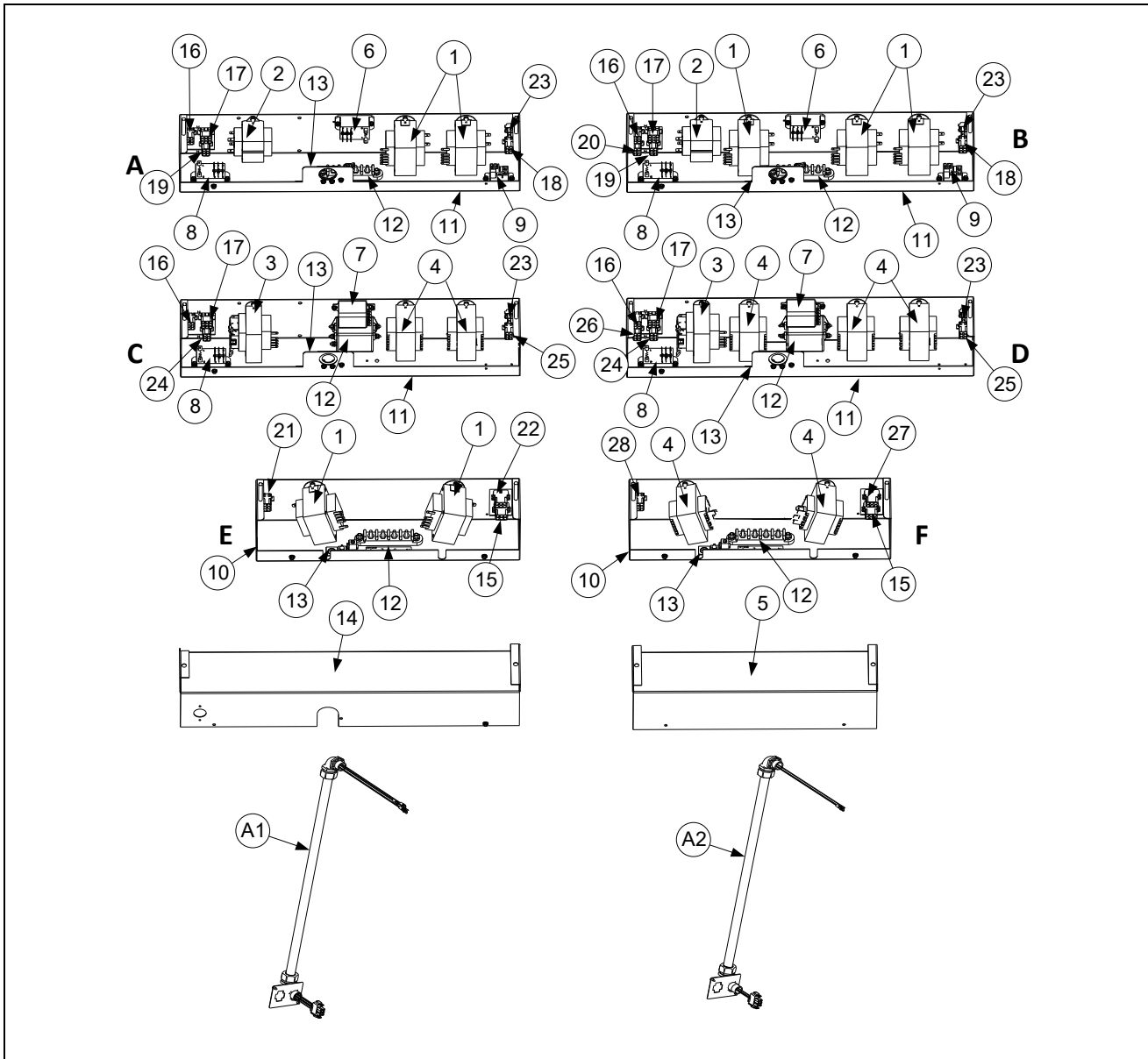

ITEM	PART #	COMPONENT
		Box Assembly, Transformer
A	1088230	230/430 Non-CE (430 has added cord set 1085662) (use 1088244 Japan)
A1	1080871	430/530 Non-CE cord set (transformer box to transformer box)
B	1088231	330 Non-CE (530 has added cord set 1085662) (use 1088245 Japan)
C	1088367	230/430 CE Export (430 has added cord set 1085662)
A2	1081788	430/530 CE cord set (transformer box to transformer box)
D	1088368	330 CE Export (530 has added cord set 1085662)
E	1087813	430/530 Non-CE 208/220/230/240V
F	1088369	430/530 CE Export 100v/120v
√ 1	8075362	Transformer, 115-240V 80VA 24VAC
√ 2	8070800	Transformer, 120V/24V 50VA Filter
√ 3	8072180	Transformer, 120V/24V 50VA Filter
√ 4	8071022	Transformer, 220/240V 75VA

√ Recommended parts.

## 1.5.2 Transformer Boxes cont.

ITEM	PART #	COMPONENT
5	2401696	Cover, 430/530 Transformer Box (Small)
√ 6	8075802	Relay, DPDT 30A 120VAC (Control Reset Button) <i>(used for control power reset in domestic units)</i>
√ 7	8074770	Relay, DPDT 20A 240V (Control Reset Button) <i>(used for control power reset in international units)</i>
√ 8	8074482	Relay, Filter Pump 30A 24VDC DPDT
√ 9	8071683	Relay, Hood 12V DC
10	8239461	Box, 430/530 Transformer (Small)
11	8239437	Box, 230/330Transformer/Filter (Large)
12	8076428	Filter, 250V 16A EMI Power Line
13	8070070	Terminal, Ground Lug
14	2203191	Cover, Transformer Box (Large)
15	1085662	Harness Assembly, Cord set Female
16	1087727	Harness, ATO/Filter Control
17	1087726	Harness, Filter Pump Motor Non-CE and CE Export
	1088246	Harness, Filter Pump Motor Japan
18	1088228	Harness, Transformer Vat #1 230/330 Non-CE
19	1087729	Harness, Transformer Vat #2 230/330 Non-CE
20	1087730	Harness, Transformer Vat #3 330 Non-CE
21	1087812	Harness, Transformer Vat #4/5 430/530 Non-CE
22	1087811	Harness, Transformer Vat #4#5 430/530 Non-CE
23	1088229	Harness, Reset Relay
24	1088373	Harness, Transformer Vat #2 230/330 CE Export
25	1088372	Harness, Transformer Vat #1 230/330 CE Export
26	1088374	Harness, Transformer Vat #3 330 CE Export
27	1088375	Harness, Transformer Vat #4/5 430/530 CE Export
28	1088376	Harness, Transformer Vat #4/5 430/530 CE Export
*	1086452	Harness Assembly Transformer to Ground with 3-wire Snap CE Export
*	WIR1221	Wire Assembly, 2 Batt Hood Relay (used in Item A)
*	WIR1222	Wire Assembly, 3 Batt Hood Relay (used in Item B)
*	WIR1198	Wire Assembly, 430/530 Transformer Box (used in Item E)
*	WIR1223	Wire Assembly, 230/430 Transformer/Filter Box (used in Item A)
*	WIR1224	Wire Assembly, Dom/Filter Box (used in Item B)
*	WIR1226	Wire Assembly, JLOV-T 3 Battery Transformer (used in Item A) Japan only
*	WIR1227	Wire Assembly, JLOV-T 3 Battery Transformer (used in Item B) Japan only
*	WIR1234	Wire Assembly, 230/330 Transformer Box CE (used in Item C and D)
*	WIR1235	Wire Assembly, 430/530 Transformer Box CE (used in Item F)

\* Not illustrated

√ Recommended parts.

### 1.5.3 FIB (Filter Interface Board) Auto Top Off / Filter Box Components **(prior to 06/2019)**

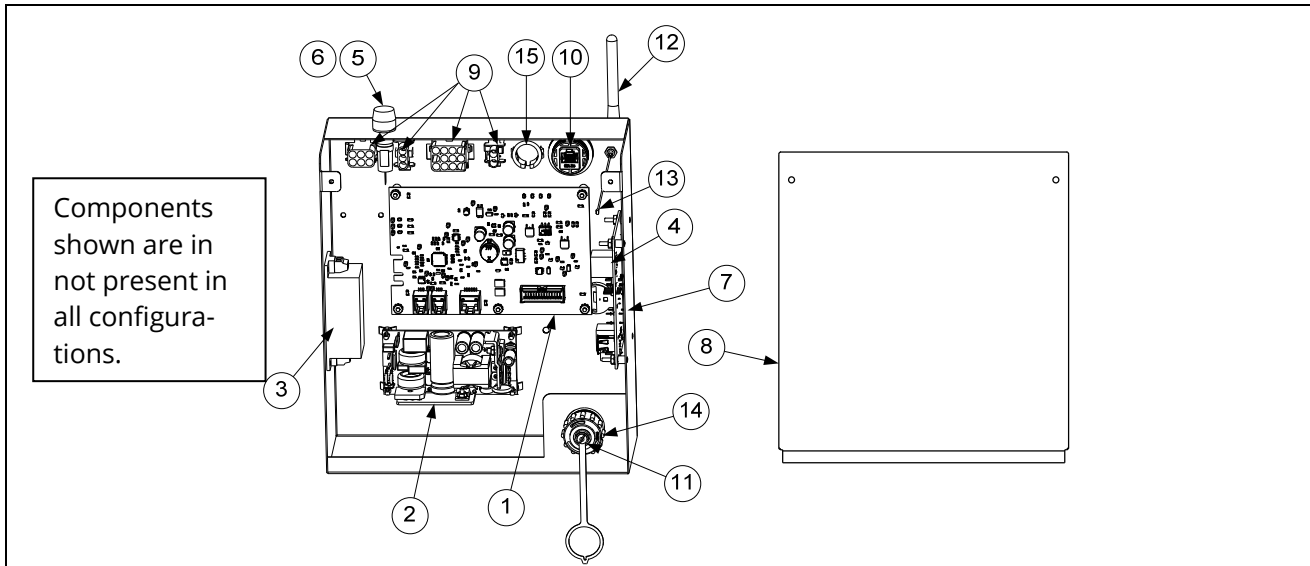

ITEM	PART #	COMPONENT
	1088033SP	Box Assembly, ATO/FIB Filter with KCCM (Use 1088032SP w/out optional KCCM)
√ 1	1086575	Board, FIB w/ Software
√ 2	8263684	Power Supply, 24VDC 130W ATO, Actuators, Filter Pump, Top Off Pump
√ 3	8075974	Power Supply, 24VDC, 15W for KCCM SUI board
*	1087247	Holder Assembly, Fuse with Leads (used with the KCCM SUI Board)
√ 4	1088445SP	PCB, Assy KCCM/SUI LOV-T
√ 5	8075570	Fuse, 250VAC 3.5A Fast Acting
6	8071321	Holder, Fuse
7	1087746	Box, Assembly
8	2401727	Cover, ATO/Filter Box
9	8076240	Harness, Bulk Oil/ATO/FIB (J1 (30-pin) FIB to illustrated connectors inside FIB Box)
10	8075967	Coupler, 8PBC to 8PBC (Ethernet RJ45)
11	8075970	Cap, Dust
12	8075975	Antenna
13	8076225	Cable, U. FL to RP-SMA Bulkhead (attaches from item 12 to Item 4)
14	8075969	Cable, USB Receptacle Mount (USB end attaches to Item 4)
15	8071926	Bushing, .875 Split
*	8074056	Connector, 3-Wire Snap
*	WIR1179	Wire Assy, FQLAU Filter/ATO Power (Connects item 1 and item 2)
		<b>See Wiring Diagrams 8052138, 8052153, 8052154 (Non-CE) or 8052191, 8052192 (CE) in BIGLA30-T Service Manual for cable locations</b>
√ *	8075632	Terminator, CAN End Communication RJ11 (FIB J4)
*	8075977	Cable, RJ45 Cat5E 7.87" (From Item 10 to Item 4)
*	8076249	Harness, Filter/ATO Power/Control 24" (C5 (6-pin) Rear FIB Box - C5 (6-pin) Transformer Box)
*	8076242	Harness, KCCM SUI Communication/Power (RJ45 item #4 to J4 FIB and to item #3)
*	8076241	Harness, Power Supply (From item #2 to Snap Connectors)
*	8075551	Cable, C-Bus Right SIB (J7) to FIB (Filtration Interface Board) (J3)
*	8075810	Cable, FIB to VIB Actuator Power (used from FIB item #1 (J2) to VIB (J4) and from VIB (J3) to VIB (J4))

\* Not illustrated √ Recommended parts.

### 1.5.3.1 FIB (Filter Interface Board) Auto Top Off/Filter Box Components (06/2019-06/2021)

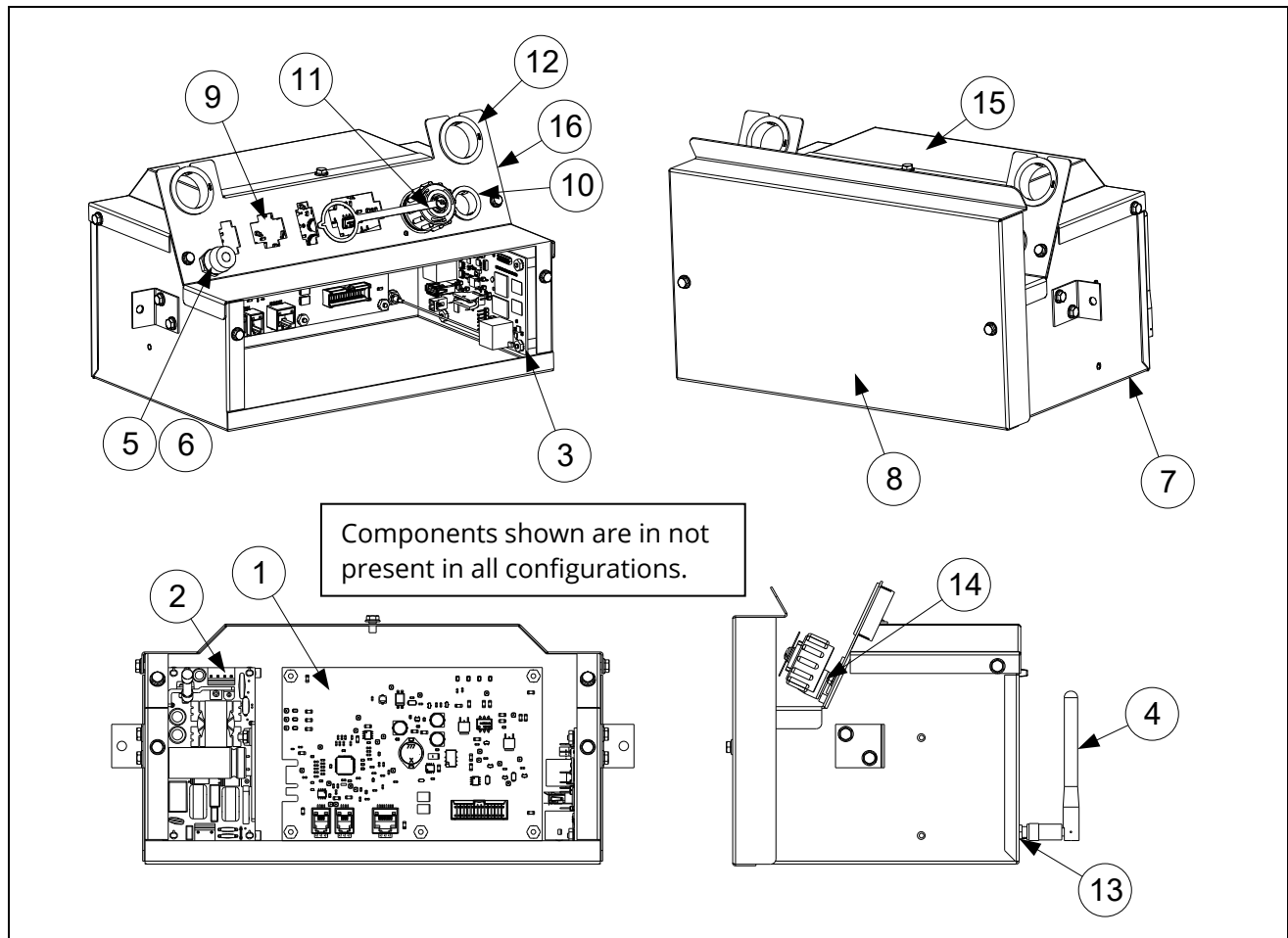

ITEM	PART #	COMPONENT
	1088330SP	Box Assembly, ATO/FIB Filter with KCCM (Use 1088575SP w/out optional KCCM)
√ 1	1086575	Board, FIB w/ Software
√ 2	8263684	Power Supply, 24VDC 130W ATO, Actuators, Filter Pump, Top Off Pump
√ 3	1088445	PCB, Assy KCCM/SUI LOV-T
4	8075975	Antenna
√ 5	8075570	Fuse, 250VAC 3.5A Fast Acting
6	8071321	Holder, Fuse
7	1088296	Box, Assembly
8	2401845	Shield, Topoff Front Cover
9	8076409	Harness, Bulk Oil/ATO/FIB/JIB Reset (J1 (30-pin) FIB to external connectors inside FIB Box)
10	8071926	Bushing, .875 Split
11	8075970	Cap, Dust
12	8072469	Bushing 1" I.D.
13	8076225	Cable, U. FL to RP-SMA Bulkhead (attaches item 4 to Item 3)
14	8075969	Cable, USB Receptacle Mount (USB end attaches to Item 3)
15	2401843	Cover, Topoff Box
16	2401844	Cover, Front Topoff
*	8074056	Connector, 3-Wire Snap
*	WIR1179	Wire Assy, FQLAU Filter/ATO Power (Connects item 1 and item 2)
		<b>See Wiring Diagrams 8052138, 8052187, 8052188 (Non-CE) or 8052201,</b>

ITEM	PART #	COMPONENT
		<b>8052202 (CE) or 8052203, 8052204 (AUS) in BIGLA30-T Service Manual for cable locations</b>
√ *	8075632	Terminator, CAN End Communication RJ11 (FIB J4)
*	8075977	Cable, RJ45 Cat5E 7.87" (From Item 10 to Item 4)
*	8076249	Harness, Filter/ATO Power/Control 24" (C5 (6-pin) Rear FIB Box - C5 (6-pin) Transformer Box)
*	8076242	Harness, KCCM SUI Communication/Power (RJ45 item #4 to J4 FIB and to item #3)
*	8076241	Harness, Power Supply (From item #2 to Snap Connectors)
*	8075551	Cable, C-Bus Right SIB (J7) to FIB (Filtration Interface Board) (J3)
*	8076315	CABLE, XL VIB Actuator Power (used from FIB item #1 (J2) to VIB (J4)
*	8075810	Cable, FIB to VIB Actuator Power (used from FIB item #1 (J2) to VIB (J4) and from VIB (J3) to VIB (J4)

\* Not illustrated √ Recommended parts.

### 1.5.3.2 FIB (Filter Interface Board) Auto Top Off/Filter Box Components (07/2021-present)

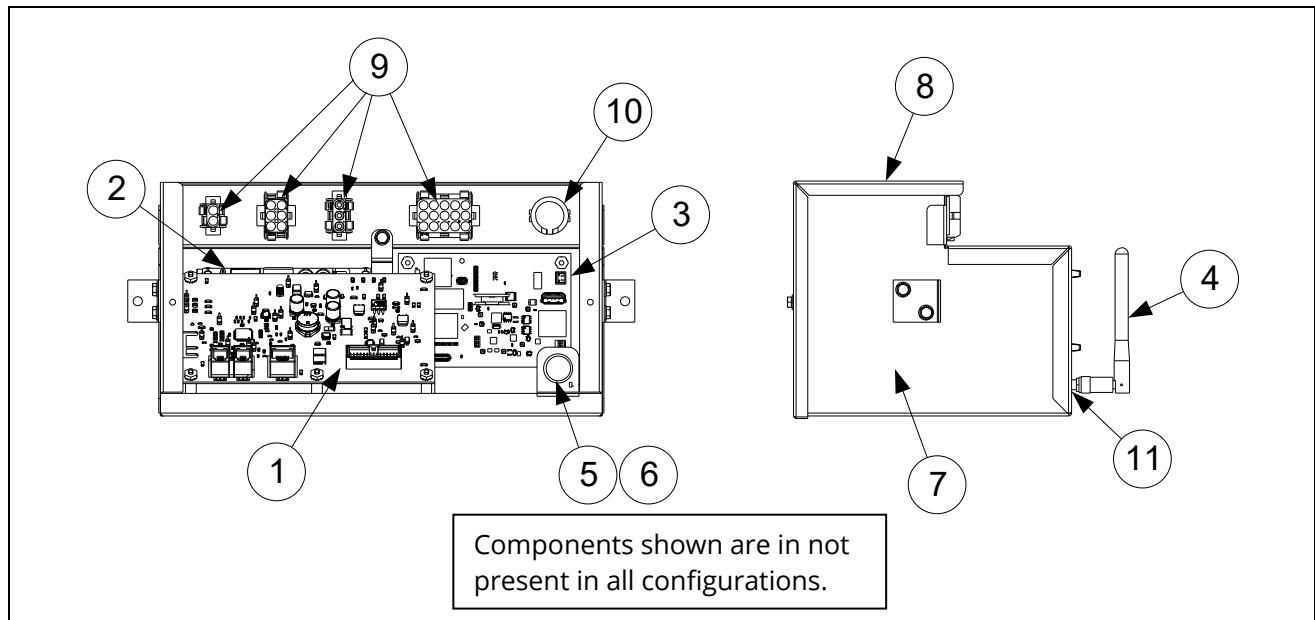

ITEM	PART #	COMPONENT
	130000121SP	Box Assembly, ATO/FIB Filter with KCCM (Use 130000275SP w/out KCCM)
√ 1	1086575	Board, FIB w/ Software
√ 2	8263684	Power Supply, 24VDC 130W ATO, Actuators, Filter Pump, Top Off Pump
√ 3	1088445	PCB, Assy KCCM/SUI LOV-T
4	8075975	Antenna
√ 5	8075570	Fuse, 250VAC 3.5A Fast Acting
6	8071321	Holder, Fuse
7	130000120	Box, Assembly
8	130000273	Cover, Topoff
9	8076409	Harness, Bulk Oil/ATO/FIB/JIB Reset (J1 (30-pin) FIB to external connectors inside FIB Box)
10	8071926	Bushing, .875 Split
11	8076225	Cable, U. FL to RP-SMA Bulkhead (attaches item 4 to Item 3)
*	8074056	Connector, 3-Wire Snap
*	WIR1179	Wire Assy, FQLAU Filter/ATO Power (Connects item 1 and item 2)
		<b>See Wiring Diagrams 8052138, 8052187, 8052188 (Non-CE) or 8052201, 8052202 (CE) or 8052203, 8052204 (AUS) in BIGLA30-T Service Manual for cable locations</b>
√ *	8075632	Terminator, CAN End Communication RJ11 (FIB J4)
*	8076241	Harness, Power Supply (From item #2 to Snap Connectors)
*	8076249	Harness, Filter/ATO Power/Control 24" (C5 (6-pin) Rear FIB Box - C5 (6-pin) Transformer Box)
*	8076242	Harness, KCCM SUI Communication/Power (RJ45 item #4 to J4 FIB and to item #3)
*	8075551	Cable, C-Bus Right SIB (J7) to FIB (Filtration Interface Board) (J3)
*	8075810	Cable, FIB to VIB Actuator Power (used from FIB item #1 (J2) to VIB (J4) and from VIB (J3) to VIB (J4))

\* Not illustrated √ Recommended parts.

### 1.5.4 VIB (Valve Interface Board) Components

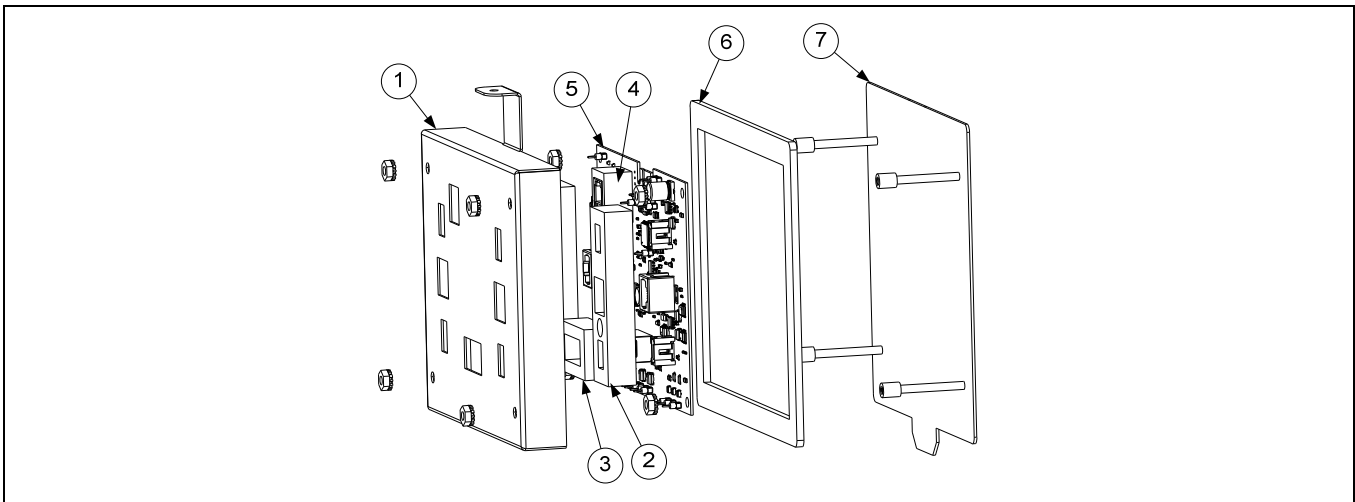

ITEM	PART #	COMPONENT
√	1085996SP	VIB Board Assembly
1	8242346	Cover, VIB Board Housing
2	8161015	Gasket, Actuator Power VIB
3	8161013	Gasket, 20 pin VIB Connector
4	8161014	Gasket, P-Bus VIB Connector
5	1086574SP	Board, VIB with SW
6	8160820	Seal, Linear Actuator Board
7	1087280	Panel, Assy VIB Box Bottom Stud

√ Recommended parts.

### 1.5.5 Power Reset Switch and USB Connector

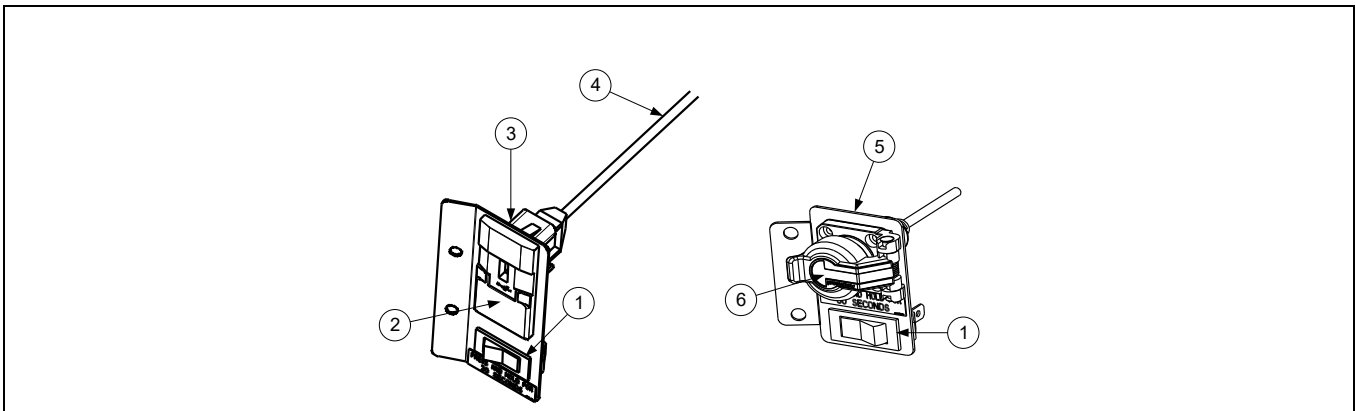

ITEM	PART #	COMPONENT
	1087802	Bracket Assy, USB Mounting
1	8072659	Switch
2	8074989	Bezel, USB Port
3	2207520	Plate, Backing USB Bezel
4	8074990	Cable, USB
	130000192	Bracket Assy, USB Mounting Gas
5	2602358	Bracket, USB/RESET
6	8105041	USB, Self-Closing Flange

## 1.6 Wiring

### 1.6.1 Wiring Harness Full Vat - SIB to Rear of Component Box

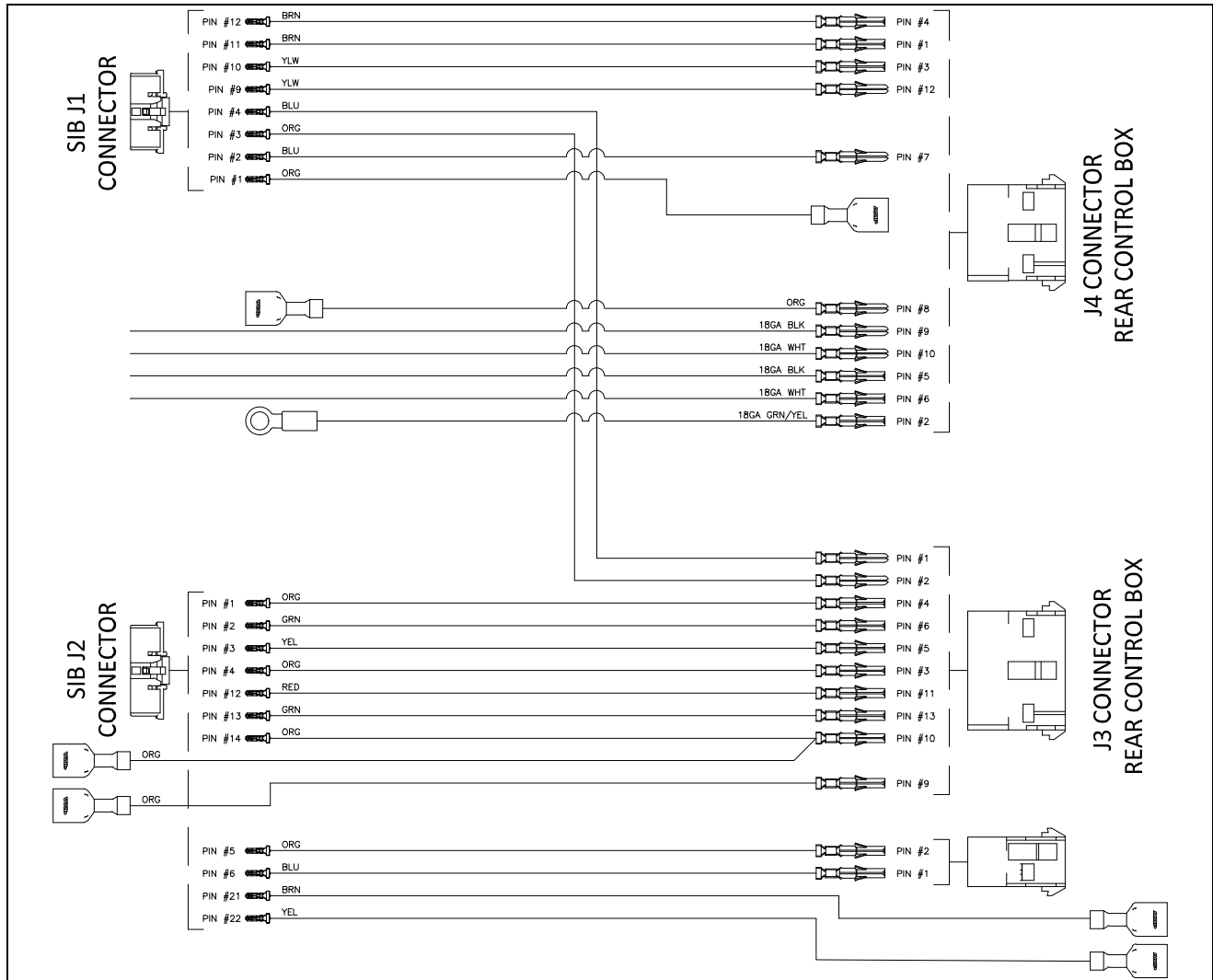

ITEM	PART #	COMPONENT
	8076364	Harness, Controls LOV-T Gas Full Vat

See the BIGLA30-T Service Manual for wiring diagram.



## 1.6.2 Wiring Harness Dual Vat - SIB to Rear of Component Box

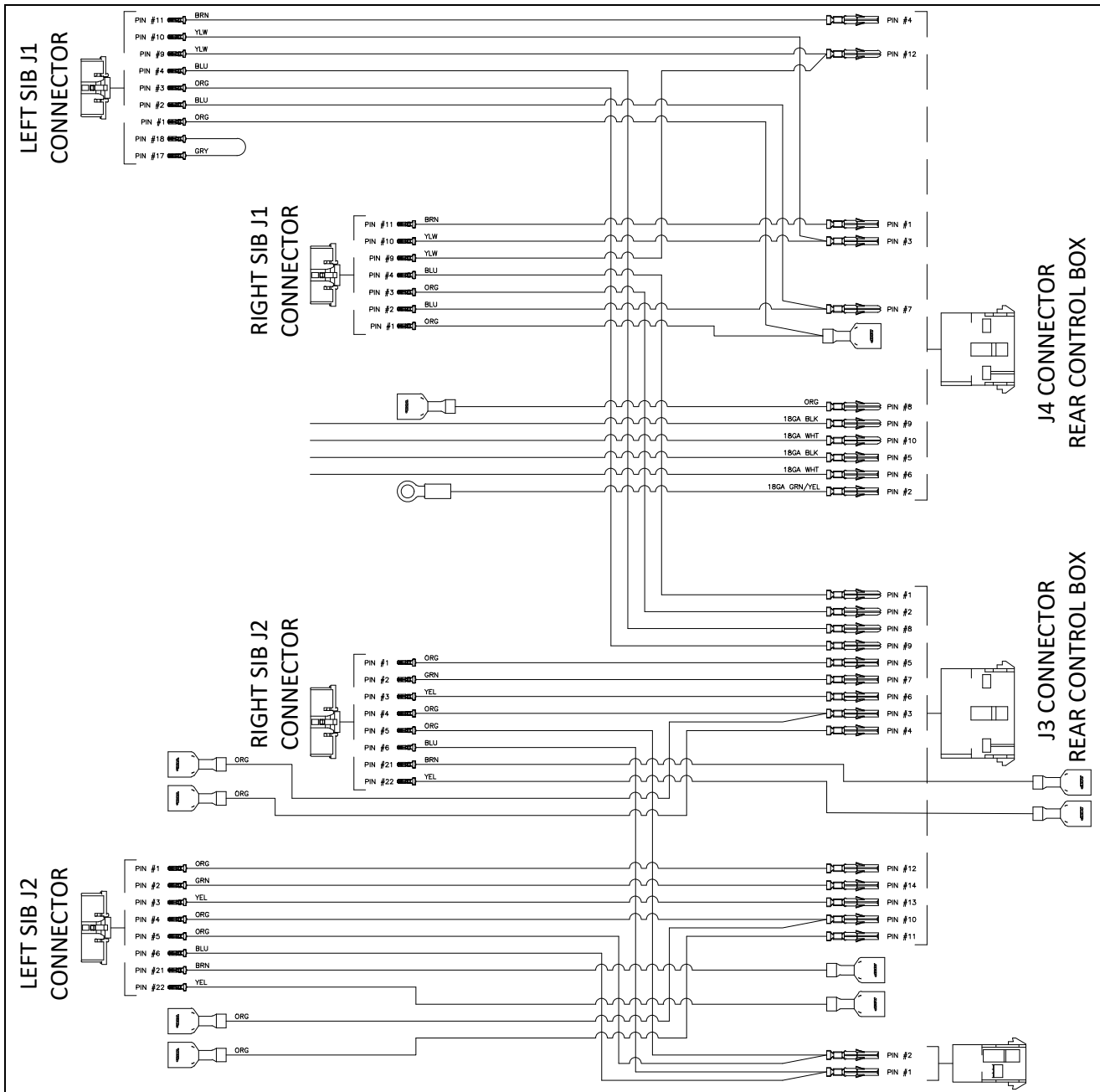

ITEM	PART #	COMPONENT
	8076365	Harness, Controls LOV-T Gas Dual Vat

See the BIGLA30-T Service Manual for wiring diagram.

### 1.6.3 Ignition Wiring Harness Full Vat - Control Box to Components

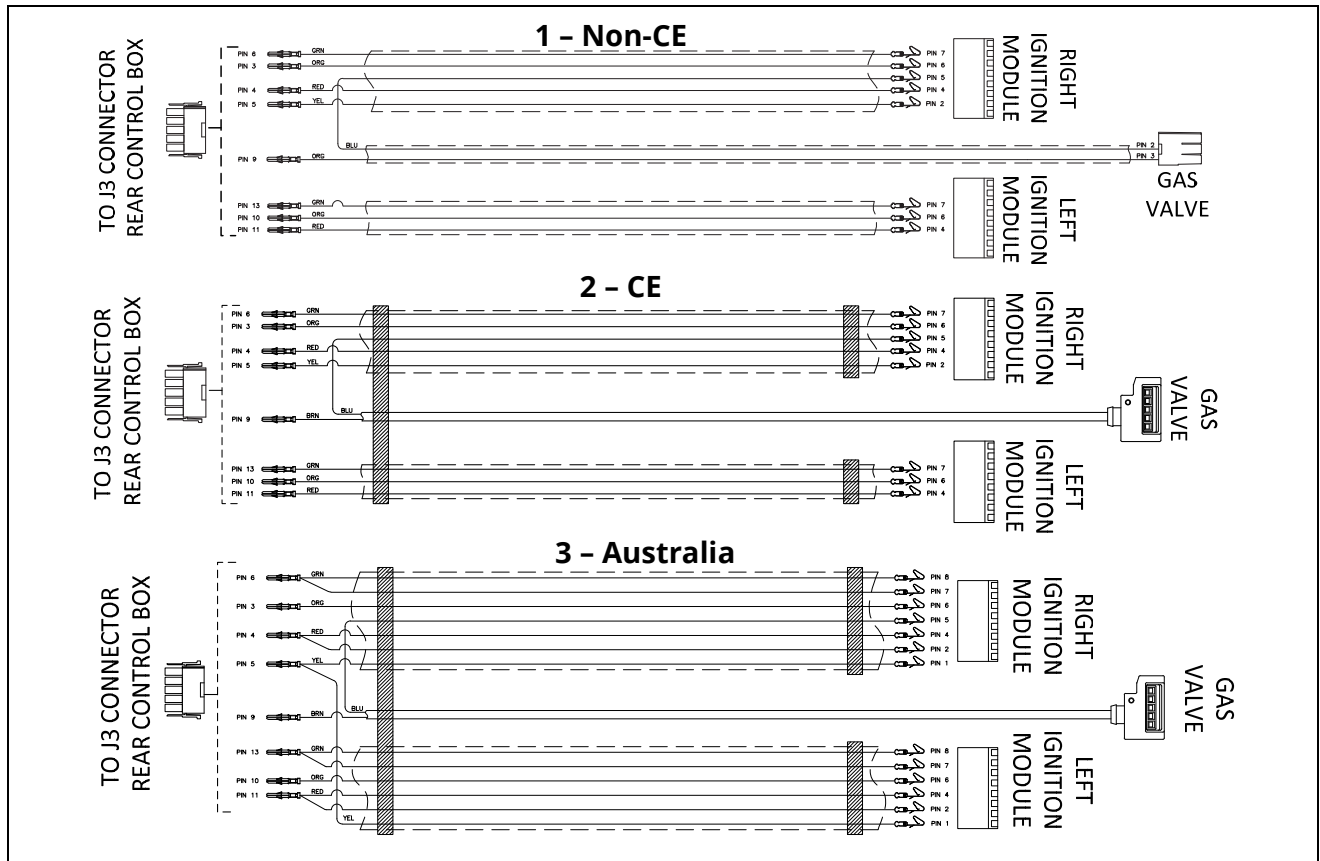

ITEM	PART #	COMPONENT
1	8076366	Harness, Ignition/Controls Wiring LOV-T Gas Full Vat Non-CE Fenwal
2	8076377	Harness, Ignition/Controls Wiring LOV-T Gas Full Vat CE Fenwal
3	8076429	Harness, Ignition/Controls Wiring LOV-T Gas Full Vat Australia Fenwal

### 1.6.4 Ignition Wiring Harness Dual Vat - Control Box to Components

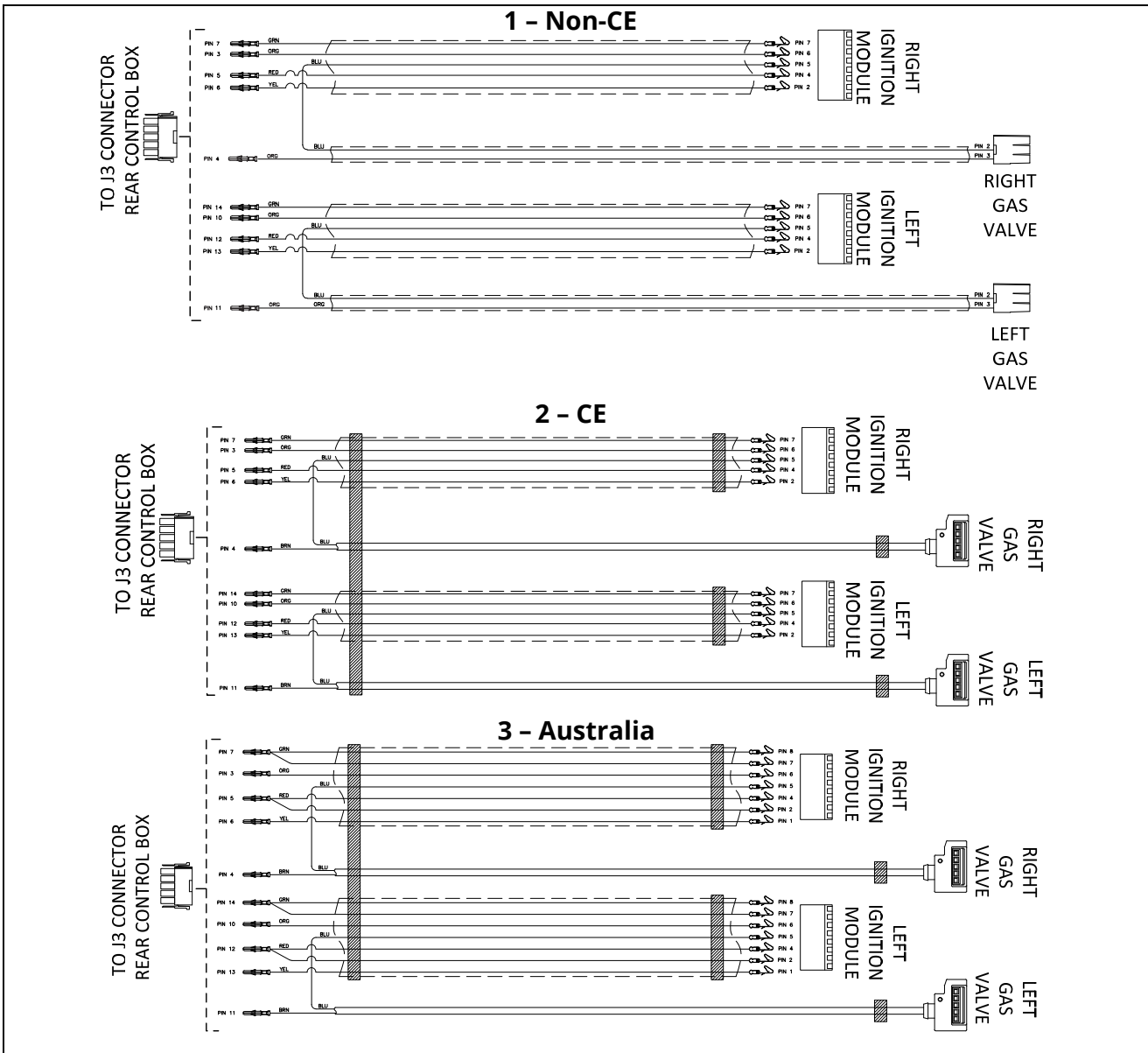

ITEM	PART #	COMPONENT
1	8076367	Harness, Ignition/Controls Wiring LOV-T Gas Dual Vat Non-CE Fenwal
2	8076378	Harness, Ignition/Controls Wiring LOV-T Gas Dual Vat CE Fenwal
3	8076430	Harness, Ignition/Controls Wiring LOV-T Gas Dual Vat Australia Fenwal

### 1.6.5 Wiring Harness Power

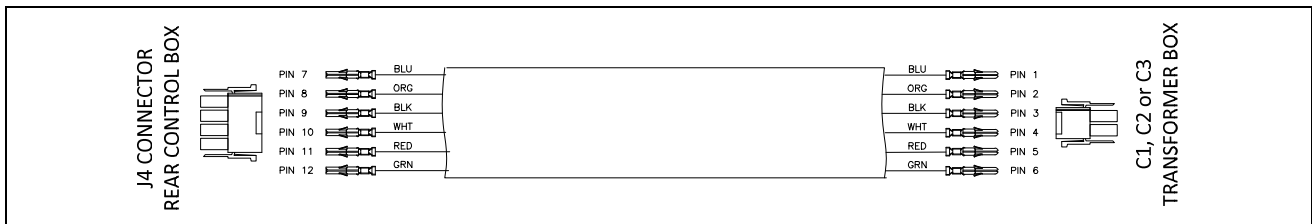

ITEM	PART #	COMPONENT
1	8076245	Harness, Vat AC Power (Rear of Component Box to Transformer Box)

## 1.6.6 FIB Box Wiring Harness

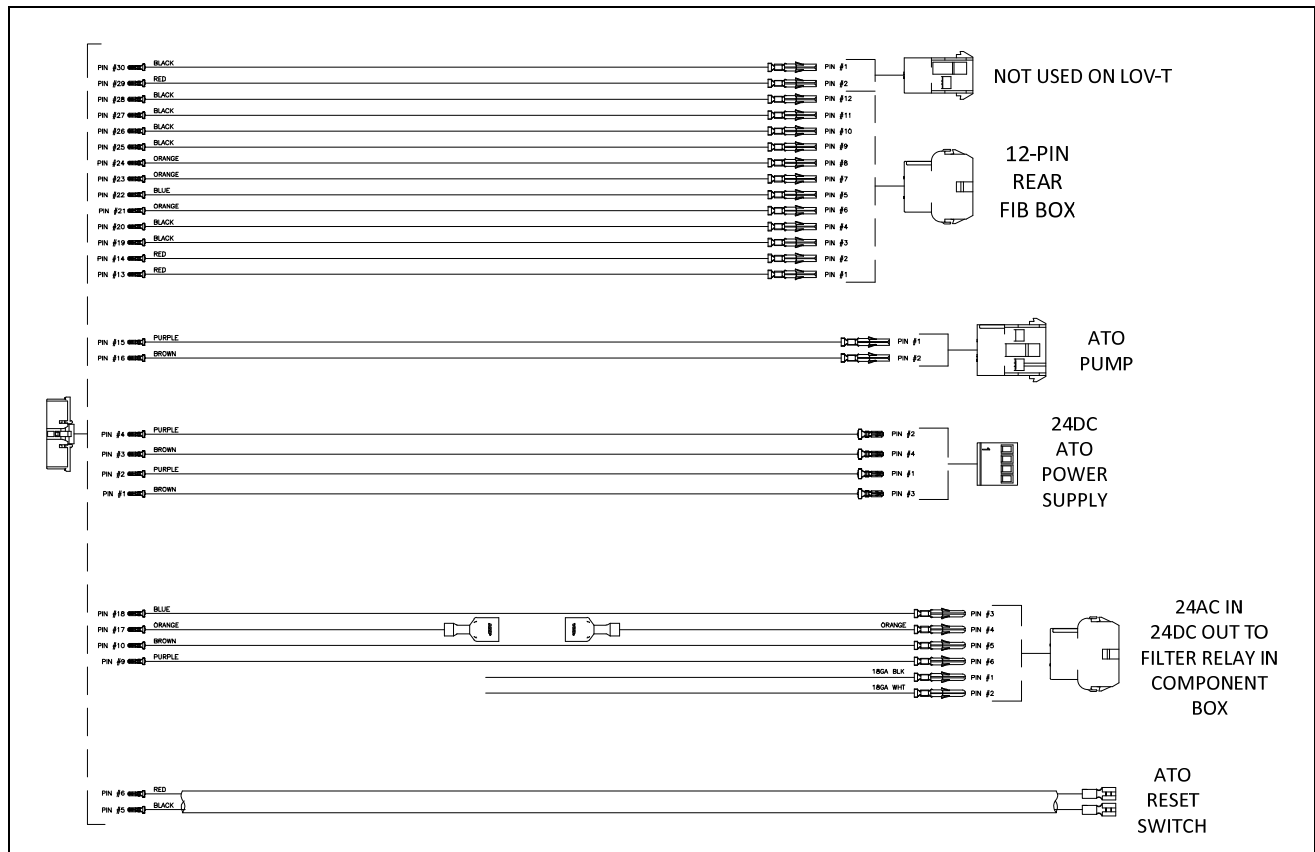

ITEM	PART #	COMPONENT
1	8076240	Harness, Bulk Oil, Topoff /FIB ( <i>Prior to 06/2019</i> )
2	8076409	Harness, Bulk Oil, Topoff /FIB ( <i>After 06/2019</i> )

## 1.6.7 Miscellaneous Wiring

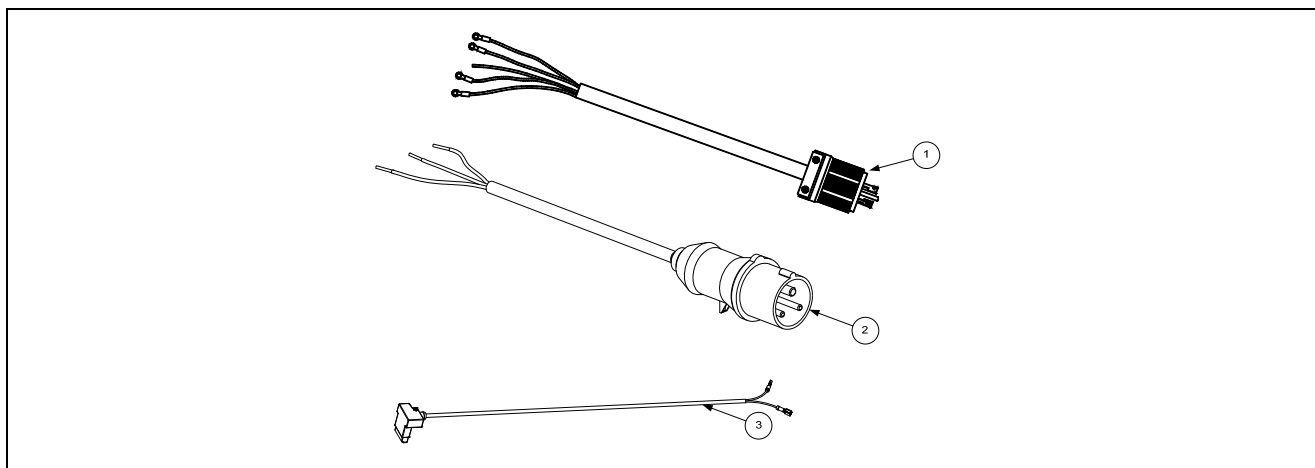

ITEM	PART #	COMPONENT
1	8074316	Power Cord, 120V w/Grounding Plug 5 wire (w/Ring Terminals, no Clamp) 96"
	8066083	Power Cord, 120V w/Grounding Plug 5 wire (w/Ring Terminals, no Clamp) 84"
2	1063244	Power Cord, CE 106"
	8075225	Power Cord, 3-Wire 15A, 250V (Korea)
3	8069678SP	Plug Assembly, CE Gas Valve

## 1.7 Frypots and Associated Components

### 1.7.1 Full-Vat Frypot Components

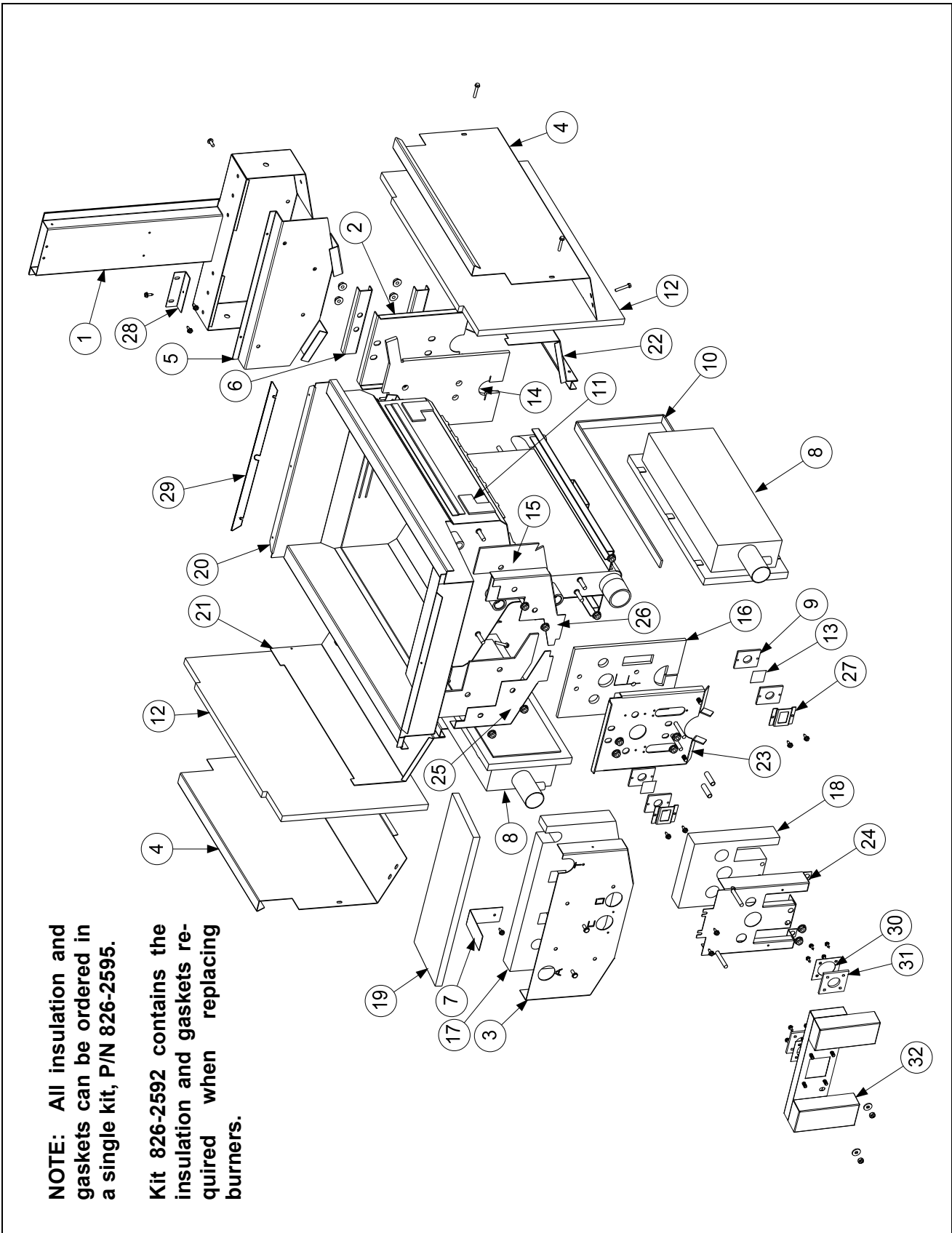

### 1.7.1 Full-Vat Frypot Components cont.

ITEM	PART #	COMPONENT
	1081752SP	Frypot Assembly Full-Vat LOV™ HE (NAT/PRO)
	8262595	Insulation Kit, Complete Full-Vat
	8262592	Insulation Kit, Burner Full-Vat
1	1080925SP	Flue Assembly, Full-Vat
2	2206470	Back, Lower Full-Vat Combustion Chamber
3	2206529	Retainer, Full-Vat Upper Insulation
4	2206664	Retainer, Outer Frypot
5	2306960	Plate, FV Collector Mounting
6	2202851	Brace, FV Rear Insulation
7	2202920	Brace, Foam Deck Insulation
√ 8	8103435	Burner, Universal Replacement LOV™
9	8120356	Insulation, Burner Sight Glass
10	8160900	Insulation, Burner
11	8120706	Insulation, Upper Burner Rail
12	8121029	Insulation, Combustion Chamber Side
13	8140048SP	Glass, Burner Sight
14	8160837	Insulation, FV Rear Lower
15	8160731	Insulation, FV LH/RH Front Seal
16	8238577	Insulation, FV Lower Inner Front
17	8160733	Insulation, FV Front Upper
18	8238575	Insulation, FV Outer Front
19	8160746	Insulation, Foam Deck
20	8238932	Frypot, FV LOV™ 30 439 SS
21	8238193	Retainer, FV LH Upper Burner
22	8238194	Retainer, FV RH Upper Burner
23	8238577	Retainer, FV Front Insulation
24	8238575	Retainer, FV Outer Front
25	8242164	Front Upper Seal Weldment, FV LH
26	8242165	Front Upper Seal Weldment, FV RH
27	9001031	Retainer, Burner Sight Glass
28	9300818	Bracket, Flue to Pot
29	9004253	Strip, Fluecap Retainer
30	9001049	Retainer, Plenum Gasket
31	8160057	Gasket, Plenum
32	8238574	Plenum, Full-Vat LOV™ <b>(use 8238590 for CE and Export Non-CE units)</b>
	8239490	Plenum, Full-Vat F5G30U <b>(use 1087976 Plenum Assy) (Japan)</b>
*	8161049	Gasket, Plenum/Blower (used between blower and plenum)
*	8161122	Seal, Frypot Plenum Mounting
*	8090390	Elbow, 90° Male 1/8" to 3/16" (used with Pressure Switches)
*	81609981	Gasket, Ignitor Solaronics
*	9102474	Pot-to-Pot Gap Clip

\* Not illustrated.

√ Recommended parts.

## 1.7.2 Dual-Vat Frypot Components

**NOTE:** All insulation and gaskets can be ordered in a single kit, P/N 826-2596.

Kit 826-2593 contains the insulation and gaskets required when replacing burners.

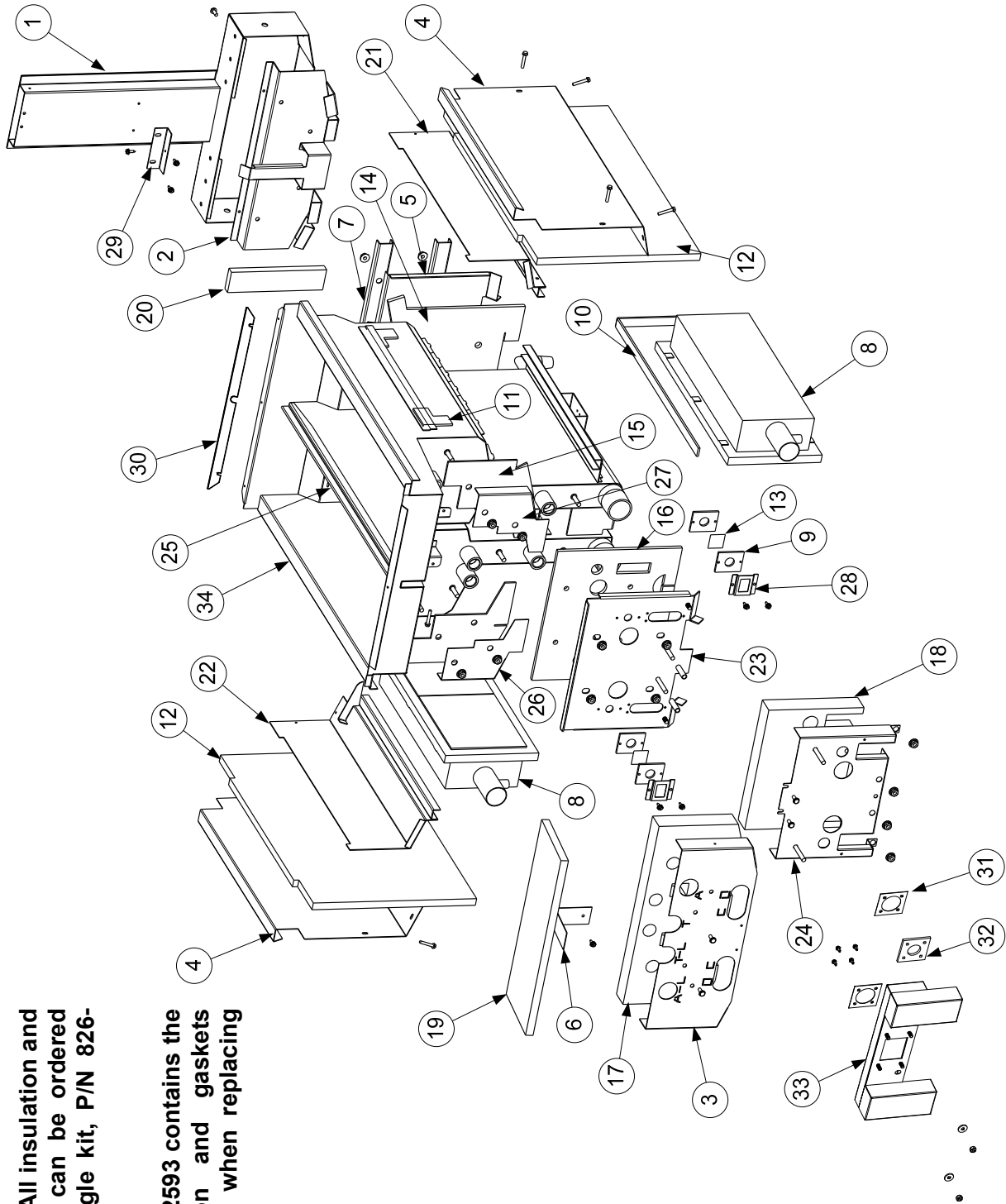

## 1.7.2 Dual-Vat Frypot Components cont.

ITEM	PART #	COMPONENT
*	1081753SP	Frypot Assembly Dual-Vat w/RF HE (NAT/PRO)
*	8262596	Insulation Kit, Complete Dual-Vat
*	8262593	Insulation Kit, Burner Dual-Vat
1	1080926SP	Flue Assembly, Dual-Vat
2	1067960	Plate Assembly, Dual-Vat Collector
3	2206530	Retainer, Dual-Vat Upper Insulation
4	2206665	Retainer, Dual-Vat Outer Frypot
5	2206180	Back, Dual-Vat Lower Combustion Chamber
6	2202920	Brace, Foam Deck Insulation
7	2202972	Brace, Dual-Vat Rear Insulation
√ 8	8103435	Burner, Universal Replacement
9	8120356	Insulation, Burner Sight Glass
10	8160900	Insulation, Burner
11	8120706	Insulation, Upper Burner Rail
12	8121029	Insulation, Combustion Chamber Side
13	8140048SP	Glass, Burner Sight
14	8160838	Insulation, Dual-Vat Rear Lower
15	8160741	Insulation, Dual-Vat LH/RH Front Seal
16	8238578	Insulation, Dual-Vat Lower Inner Front
17	8160743	Insulation, Dual-Vat Front Upper
18	8160979	Insulation, Dual-Vat Outer Front
19	8160746	Insulation, Foam Deck
20	8120688	Insulation, Flue Collection
21	8238196	Retainer, Dual-Vat RH Upper Burner
22	8238195	Retainer, Dual-Vat LH Upper Burner
23	8238578	Retainer, Dual-Vat Front Insulation
24	8238576	Retainer, Dual-Vat Outer Front
25	8241796	Riser W/A Dual-Vat Pot
26	8242166	Dual-Vat LH Upper W/A Seal
27	8242167	Dual-Vat RH Upper W/A Seal
28	9001031	Retainer, Sight Glass
29	9300818	Bracket, Flue to Pot
30	9004253	Strip, Fluecap Retainer
31	9001049	Retainer, Plenum Gasket
32	8160057	Gasket, Plenum
*	8160981	Gasket, Ignitor Solaronics
33	8238573	Plenum, Dual-Vat LOV™ ( <b>use 8238589 for CE units and Export Non-CE units</b> )
	8238645	Plenum, Dual-Vat F5G30U-2 ( <b>use 1086672 Plenum Assy</b> ) (Japan)
*	8161049	Gasket, Plenum/Blower (used between blower and plenum)
*	8161122	Seal, Frypot Plenum Mounting
*	8090390	Elbow, 90° Male 1/8" to 3/16" (used with Pressure Switches)
34	8238942	Frypot, Dual-Vat LOV™ 30 439 SS
*	9102474	Pot-to-Pot Gap Clip

\* Not illustrated.

√ Recommended parts.



### 1.7.3 Frypot Assemblies and Associated Parts

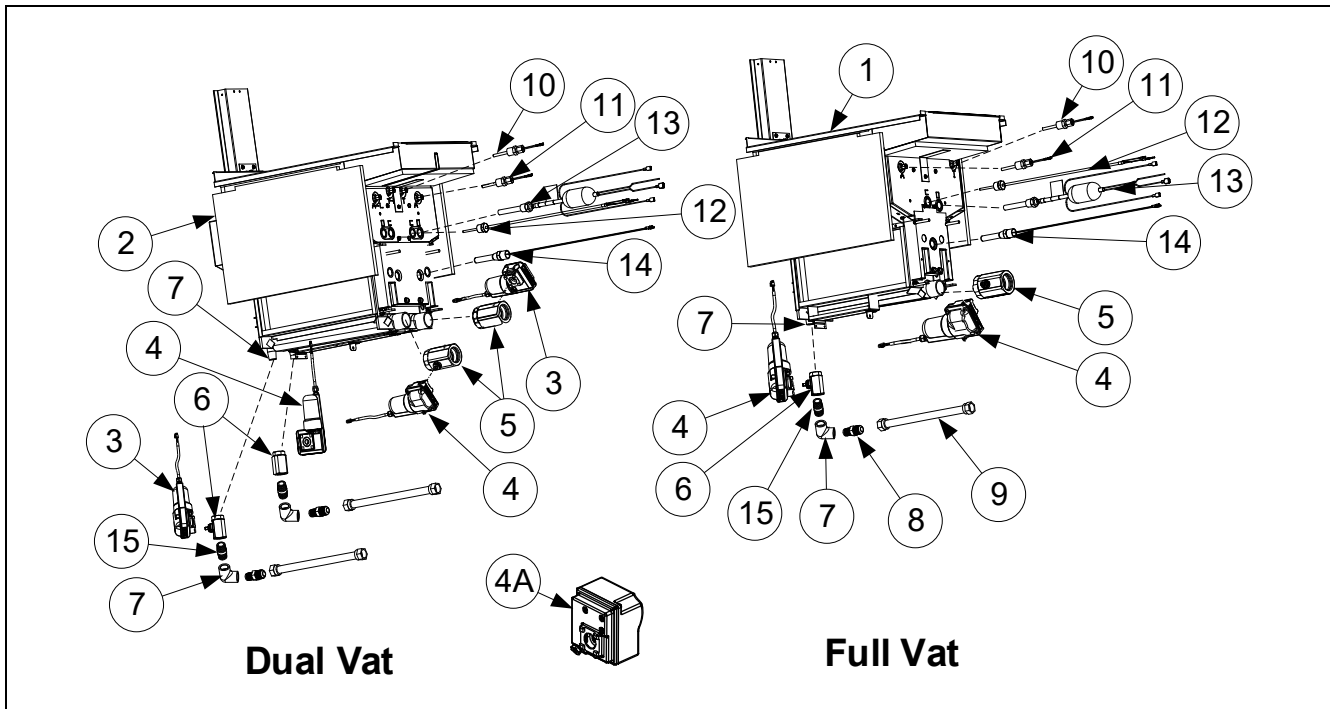

ITEM	PART #	COMPONENT
1	1081752SP	Frypot Assembly, Full-Vat Natural/Propane
2	1081753SP	Frypot Assembly, Dual-Vat Natural/Propane
√ 3	8075809	Actuator, Rotary 24VDC (#1) <b>(Blue)</b>
√ 4	8075808	Actuator, Rotary 24VDC (#2) <b>(Black)</b>
4A	130013720	Actuator, Rotary 24VDC <b>(Gray Square)</b>
√ 5	8104353	Valve, 1¼" NPT Drain
√ 6	8103754	Valve, ½" NPT Return
7	8130062	Elbow, ½" 90°
8	8101668	Adaptor, Male ⅝" OD x ½"
9	8101055	Flexline, ⅝" OD x 11.50" Long
√ 10	8263286	Probe, ATO (Topoff) RTD Kit
√ 11	8263287	Probe, VIB (Auto Filtration) RTD Kit
*	8130617	Fitting, 3/16" CC x ¼" (Compression fitting used in probe kits)
*	8158000	Loctite 567, Tube 6 ML
√ 12	8263285	Probe, Temperature Cooking Kit
√ 13	8075730	Sensor Assy, Oil 100V <b>Japan</b>
	8076384	Sensor Assy, Oil 120V
	8076385	Sensor Assy, Oil 220V <b>International</b>
	8076386	Sensor Assy, Oil 230V <b>International</b>
	8076387	Sensor Assy, Oil 240V and 250V <b>International</b>
√ 14	8261177	Thermostat Assembly, HE High-Limit 425°F/218°C Kit
√ 15	8130022	Nipple, ½" x Close NPT

**Always replace with the same type/color of actuator that was removed.**

\* Not illustrated. √ Recommended parts.

## 1.8 Oil Return Manifolds

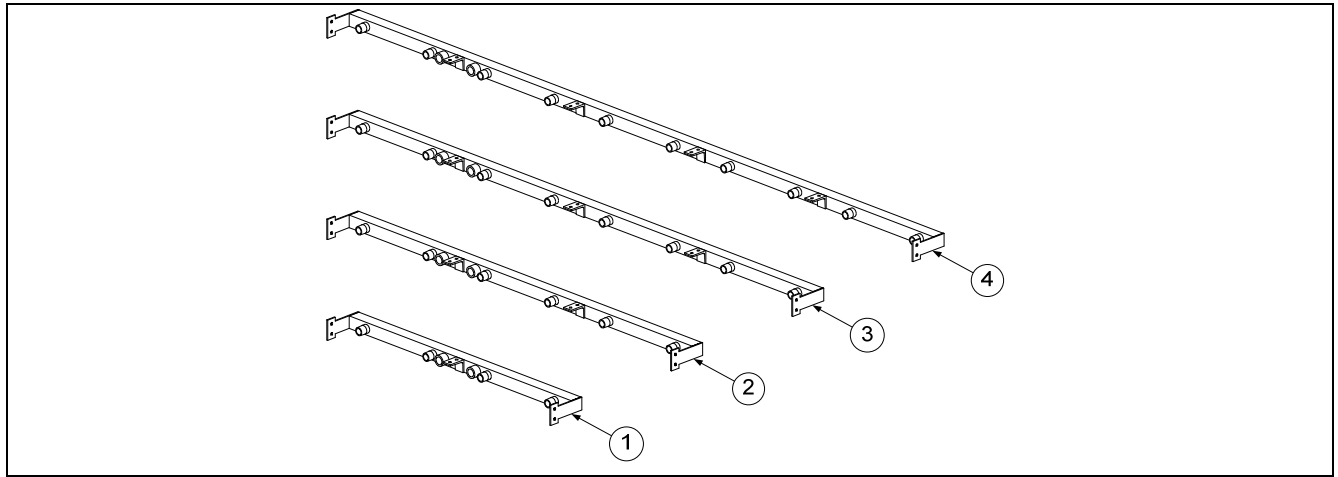

ITEM	PART #	COMPONENT
1	8105025	Manifold, Two-Station Fryer
2	8105026	Manifold, Three-Station Fryer
3	8105027	Manifold, Four-Station Fryer
4	8105022	Manifold, Five-Station Fryer
*	8130907	Cap, 15/16" Valve

## 1.9 Gas Supply and Combustion System Components

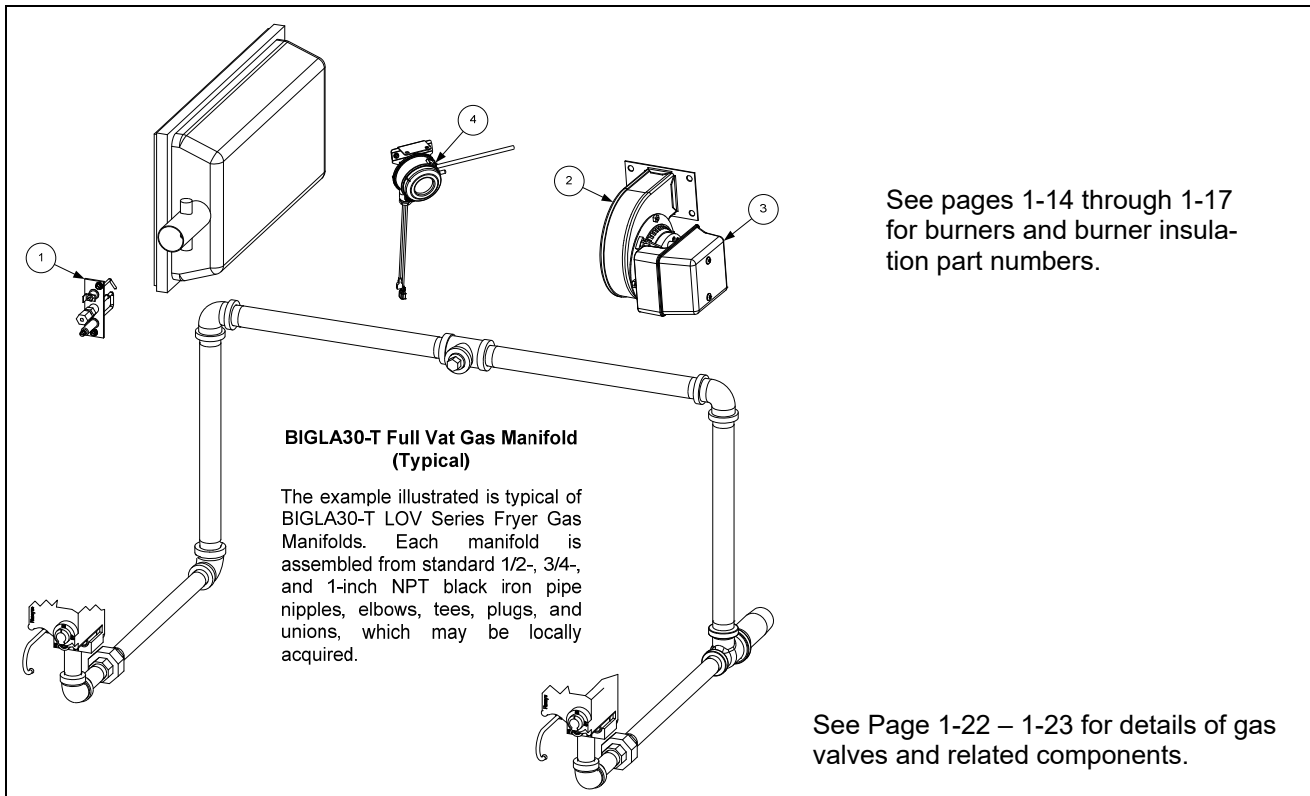

ITEM	PART #	COMPONENT
√ 1		Ignitor
	8263549	Natural Gas (G20, G25) (includes gasket 8160981, which may be ordered separately)
	8263692	Natural Gas (13-A) (includes gasket 8160981) Ceramic (Japan)
	8263552	Propane (G30, G31) (includes gasket 8160981, which may be ordered separately)
	8263693	LPG/Propane/Butane (includes gasket 8160981) Ceramic (Japan)
√ 2		Blower Assembly, Combustion Air (includes harness and Item 3)
	8263472	100V 60 Hz (Right) CE (Wide Body) Dual Vat – 1.50" opening
	1086012SP	100V 50/60 Hz CE (Right) CE (Wide Body) Dual Vat – 7 slots open
	1085699SP	100V 50/60 Hz CE (Right) CE (Wide Body) Full Vat – 8 slots open
	1062999SP	100V 50/60 Hz CE (Right) 60Hz Specific
	1087153SP	115V 50/60 Hz (Right)
	1087155SP	220V 60 Hz (Right)
	1062998SP	208-240V 50/60 Hz (Right) Non-CE International
	1088421SP	230V 50Hz CE FV Australia
	1088422SP	230V 50Hz (Right) CE DV Australia
	1063001SP	230V 50/60 Hz CE (Right) CE (Wide Body)
*	8161049	Gasket, Plenum/Blower (used between plenum and blower)
3	8160554	Cover, Blower Motor (component of most blowers listed above)
*	8068806SP	Harness Assembly, Blower Motor (component of all blowers listed above)
√ 4	1083346	Switch, Air Pressure Assembly FV (8122226 switch alone) CE and Export
√	1081455SP	Switch, Air Pressure Assembly DV (8122141 switch alone) CE and Export
√	8263465	Switch, Air Pressure Assembly FV/DV (1087779SP switch alone) Japan

\* Not illustrated. √ Recommended parts.

## 1.9 Gas Supply and Combustion System Components cont.

ITEM	PART #	COMPONENT
√	1083542	Switch, Air Pressure Assembly FV (8122226 switch alone) Australia
√	1083541	Switch, Air Pressure Assembly DV (8122141 switch alone) Australia
*	1088243	Harness, Air Pressure Switch (Air Switch to J5)
		Gas Conversion Kits
*	8262965	Conversion Kit, Natural Gas FV (G20, G25) to Propane/Butane (G30, G31) Non-CE
*	8262966	Conversion Kit, Natural Gas DV (G20, G25) to Propane/Butane (G30, G31) Non-CE
*	8262967	Conversion Kit, Propane/Butane FV (G30, G31) to Natural Gas (G20, G25) Non-CE
*	8262968	Conversion Kit, Propane/Butane DV (G30, G31) to Natural Gas (G20, G25) Non-CE
*	8262969	Conversion Kit, Nat Gas FV (G20, G25) to Prop/Butane (G30, G31) Aust Non-CE
*	8262970	Conversion Kit, Nat Gas DV (G20, G25) to Prop/Butane (G30, G31) Aust Non-CE
*	8262971	Conversion Kit, Prop/But FV (G30, G31) to Natural Gas (G20, G25) Aust Non-CE
*	8262972	Conversion Kit, Prop/But DV (G30, G31) to Natural Gas (G20, G25) Aust Non-CE
*	8262975	Conversion Kit, Nat Gas (G20, G25) to Prop/Butane (G30, G31) CE
*	8262976	Conversion Kit, Prop/Butane (G30, G31) to Natural Gas (G20, G25) CE
*	8263649	Natural to Propane (LP) Full/Dual Vat Japan
*	8263694	Natural (13A) to Propane (LP) Full/Dual Vat Ceramic Japan
*	8263650	Propane (LP) to Natural Full/Dual Vat Japan
*	8263695	Propane (LP) to Natural (13A) Full/Dual Vat Ceramic Japan

\* Not illustrated. √ Recommended parts.

## 1.10 Gas Valves and Associated Components

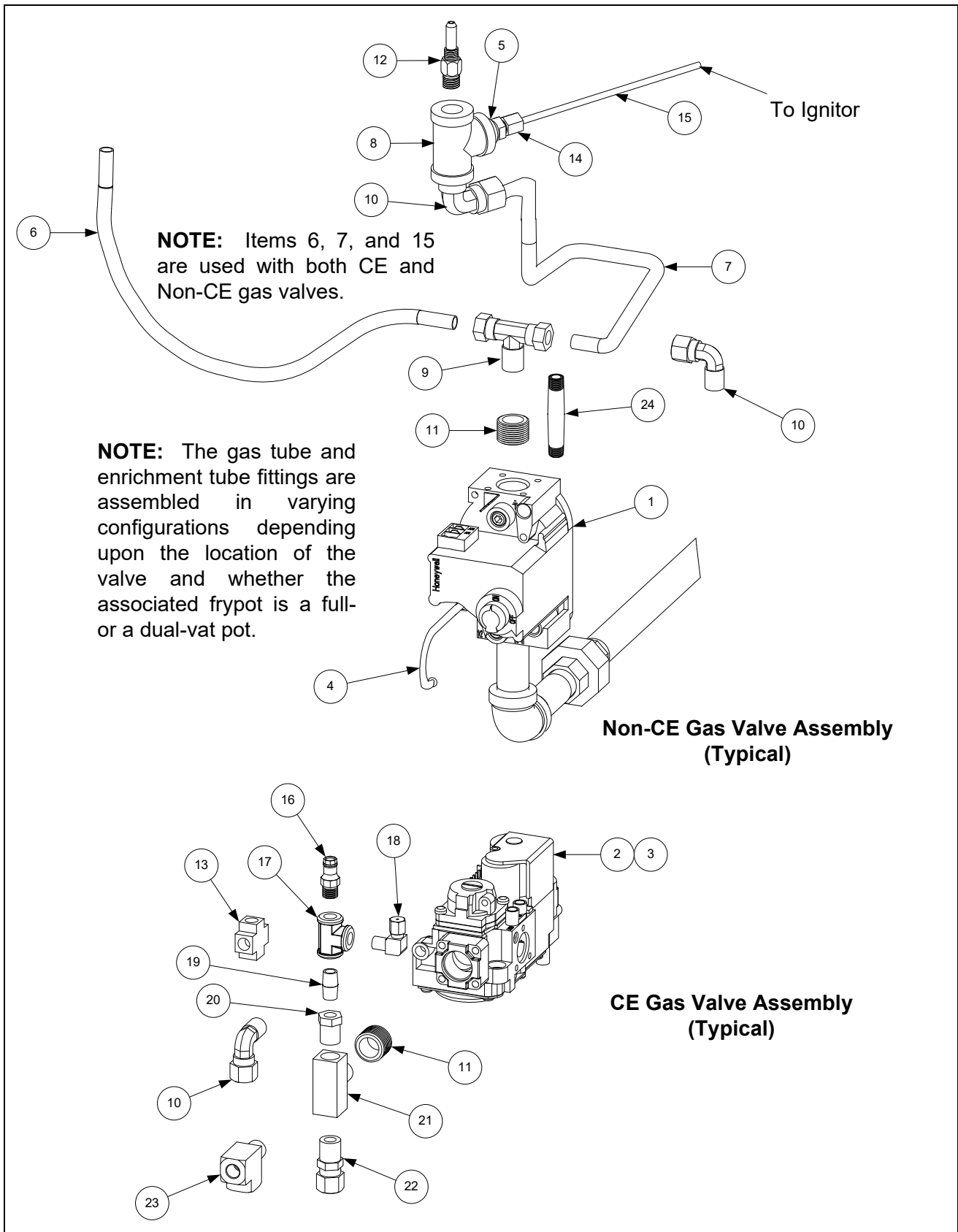

## 1.10 Gas Valves and Associated Components cont.

ITEM	PART #	COMPONENT
		<b>Gas Conversion Kits</b>
	<b>8262969</b>	<b>Natural to Propane (LP) Full Vat</b>
	<b>8262970</b>	<b>Natural to Propane (LP) Dual Vat</b>
	<b>8263649</b>	<b>Natural to Propane (LP) Full/Dual Vat Japan</b>
	<b>8263694</b>	<b>Natural (13A) to Propane (LP) Full/Dual Vat Ceramic Japan</b>
	<b>8262971</b>	<b>Propane (LP) to Natural Full Vat</b>
	<b>8262972</b>	<b>Propane (LP) to Natural Dual Vat</b>
	<b>8263650</b>	<b>Propane (LP) to Natural Full/Dual Vat Japan</b>
	<b>8263695</b>	<b>Propane (LP) to Natural (13A) Full/Dual Vat Ceramic Japan</b>
√ 1		Valve, Non-CE Gas
	8261122	Natural Gas (G20, G25) 3.2WC
	8261123	Propane Gas (G30, G31)
	8263296	Kit Natural Gas Full Vat w/ flexlines and hardware
	8263297	Kit Natural Gas Dual Vat w/ flexlines and hardware
	8261123	Kit, Propane Gas Conversion Service (G30, G31)
	8263298	Kit, Propane Gas Full Vat w/ flexlines and hardware
	8263299	Kit, Propane Gas Dual Vat w/ flexlines and hardware
√ 2	8101715	Valve, CE Gas (G20, G25, G30, G31)
3	8101041	Accessory Kit (contains parts to adapt Item 2 to specific fryer configuration)
4	8100691	Tube, 1/8" Vent
5	8103147	Bushing, 3/4" OD x 1/2" ID NPT Flush
6	8101355	Gas Line, 3/8" OD X 15" SS Flexible
7	8101354	Gas Line, 3/8" OD X 12" SS Flexible (use 8101353 for 9" for some DV pots)
8	8130449	Tee, 1/4" NPT Brass
9	8130301	Tee, 1/4" Male NPT to 3/8" Tube
10	8130302	Elbow, 1/4" Male NPT to 3/8" Tube 90° (used on DV valve)
11	8130304	Bushing, 1/2" NPT to 1/4" NPT Flush Reducing
12		Orifice, Burner
	8103977	1.88mm 75% Butane/25% Butane (Standard Elevation)
	8103865	1.95mm Propane/Butane (G30, G31)
	8103860	2.05 mm Propane/Butane (G30, G31) (0-4999 Ft, 0-1524 M)
	8103863	2.10 mm Propane/Butane (G30, G31) (5000-6999 Ft, 1525-2133 M)
	8103867	2.84mm Natural Gas (G20, G25) Australia Only DV
	8103866	2.92mm Natural Gas (G20, G25) Australia Only FV
	8103864	3.18 mm Natural Gas (G20, G25) (0-4999 Ft, 0-1524 M) CE
	8103861	3.26 mm Natural Gas (G20, G25) (0-4999 Ft, 0-1524 M)
	8103862	3.40 mm Natural Gas (G20, G25) (5000-6999 Ft, 1525-2133 M)
13	8130378	Fitting, 1/8" NPT Cross
14	8130340	Adapter, 1/8" NPT to 1/8" Tube
15	8104238	Tube, 1/8" OD X 5.40" Enrichment FV
	8104239	Tube, 1/8" OD X 4.80" Enrichment DV
16	8101176	Tap, 1/8" NPT Pressure
17	8130377	Tee, 1/8" NPT Female
18	8130354	Elbow, 1/8" NPT X 1/8" Tube Compression
19	8130016	Nipple, 1/8" NPT X Close
20	8101006	Bushing, 1/4" NPT to 1/8" NPT Reducing
21	8130495	Tee, 1/4" Male NPT to Female NPT
22	8101025	Connector, 1/4" Male NPT to 3/8" Tube
23	8101026	Tee, 1/4" Male NPT to Female NPT Street
24	8130700	Nipple, 1/4" NPT x 3"

√ Recommended parts.

## 1.11 Filtration System Components

Pump plumbing and other parts may differ somewhat from illustration depending on configuration and date of manufacture.

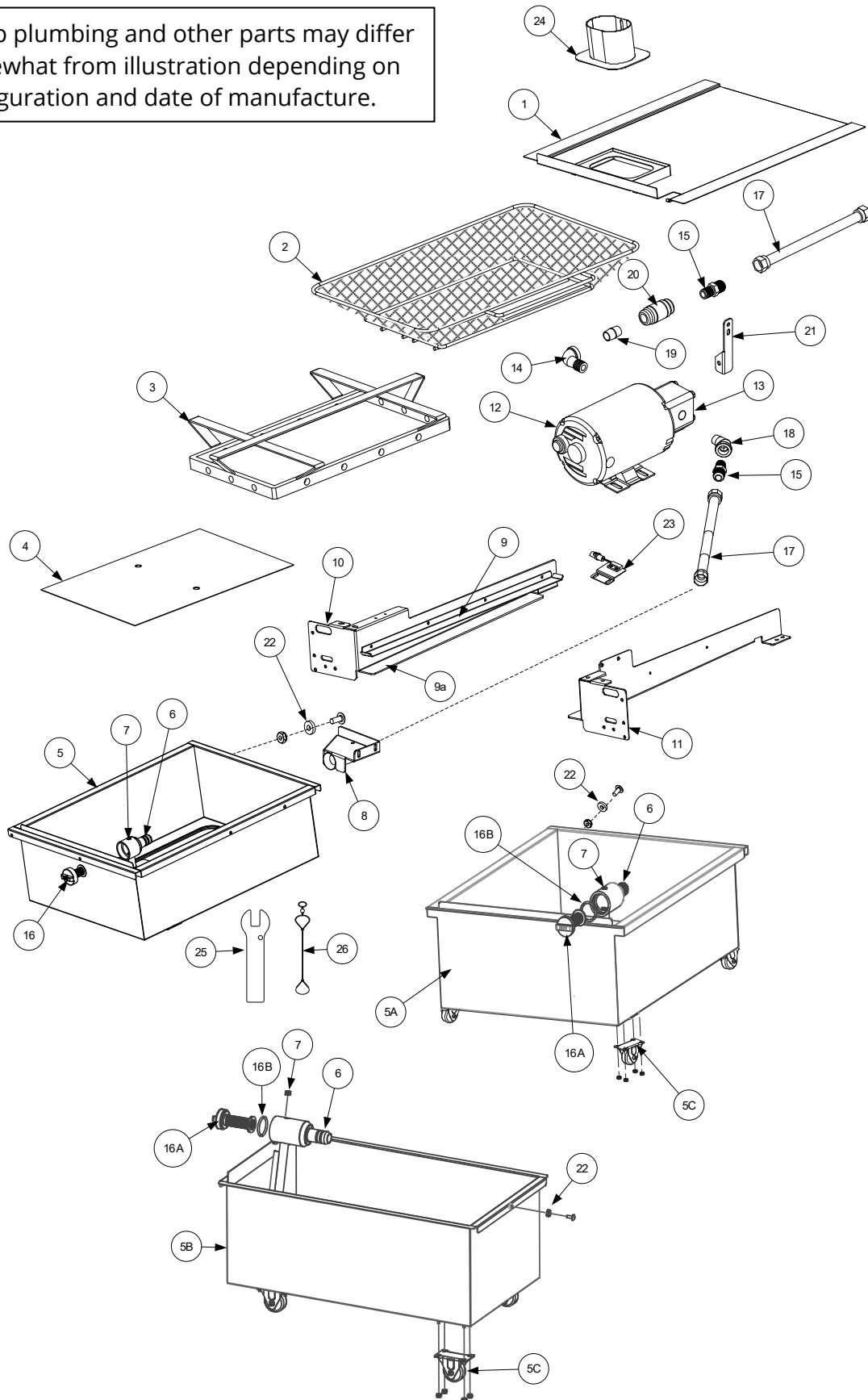

ITEM	PART #	COMPONENT
1	8237602	Lid, Multi-Vat Fryers, Standard Size Filter Pan (3, 4, and 5 Vat Fryers)
	130001001	Lid, Two-Vat Fryer, Half Size Filter Pan (2-Vat Fryer)
2	8103276	Crumb Tray, Standard Size Filter Pan (3, 4, and 5 Vat Fryers)
	8103288	Crumb Tray, Two-Vat Fryer, Half Size Filter Pan (2-Vat Fryer)
3	8103268	Hold-Down Ring 16.56" x 22.32", Standard Size Pan (3, 4, and 5 Vat Fryers)
	8103289	Hold-Down Ring 11.20" x 19.10", Half Size Filter Pan (2-Vat Fryer)
4	2002240	SanaGrid Filter Screen, Standard Size Filter Pan (3, 4, and 5 Vat Fryers)
	2202901	SanaGrid Filter Screen, Two-Vat Fryer, Half Size Filter Pan (2-Vat Fryer)
5	1088311SP	Pan, Filter LOV-T Standard Size w/ Short Pre-Filter (3, 4, and 5 Vat Fryers) <b>without casters prior to 11/2022</b>
	1088464SP	Pan, Filter LOV-T Standard Size w/ Short Pre-Filter (3, 4, and 5 Vat Fryers) <b>with casters prior to 11/2022</b>
	1088399SP	Pan, Filter LOV-T Half Size w/ Short Pre-Filter (2-Vat Fryer) <b>with casters prior to 11/2022</b>
5A	130001325	Pan Filter, LOV-T Standard w/ Long Pre-Filter (3, 4, & 5 Vat Fryers) <b>with casters 03/2024 to current (replaced 130000521 without casters 11/2022-03/2024)</b>
5B	130001321	Pan, Filter LOV-T Half Size w/ Long Pre-Filter (2-Vat Fryer) <b>with casters 03/2024 to current (replaced 130000519 without casters 11/2022-03/2024)</b>
5C	8104137	Caster, 2" Low Profile Rigid (attached w/ 4 - 8090256 Nut KEPS 10-32 Hx)
√ 6	8263288	O-Ring (8161041) (Qty. of 6; used w/ Item 5)
7	8130989	Plug, 1/8" Socket Head Pipe (used with Item 5)
8	8239501	Suction Tube Standard LOV™ (3, 4, and 5 Vat Fryers)
9	2203879	Rail, Filter Pan Retaining Standard (3, 4, and 5 Vat Fryers)
	2314821	Rail, Filter Pan Retaining Left (use 2324822 for Right) (2-Vat Fryer)
9a	2304820	Rail, RH LH Lower (2-Vat Fryer)
10	2207911	Support, Left Filter Pan (3, 4, and 5 Vat Fryers)
	2207909	Support, Left Filter Pan (2-Vat Fryer)
11	2207912	Support, Right Filter Pan (3, 4, and 5 Vat Fryers)
	2207910	Support, Right Filter Pan (2-Vat Fryer)
√ 12		Motor and Gasket Kit
	8261785	100V 50/60 Hz
	8261712	115V 50/60 Hz
	8261756	208V 50/60 Hz
	8261270	220-240V 50/60 Hz
	8261755	250V 50/60 Hz
√ 13	8263191	Pump and Gasket Kit, 4 GPM
	8160093	Gasket, Pump/Motor
*	8091062	Cap Screw, 5/16"-18 4.00" NC Hex (Connects pump to motor use 8090194 washers)
14	8130165	Elbow, ST 1/2" x 1/2" NPT 90° BM
15	8101668	Adapter, 5/8" to 1/2" NPT Male
16	8238335	Screen, Suction Line Filter
16A	8239651	Screen, Suction Line w/O-Ring
16B	8161213	O-Ring, Inline Filter Cap
17	8101057	Flexline, 5/8" OD x 13.00"
	8101055	Flexline, 5/8" OD x 11.50"
	8101369	Flexline, 5/8" OD x 17.50"
	8101069	Flexline, 5/8" OD x 29.50"
18	8130342	Elbow, Street 45° x 1/2" NPT
19	8130002	Nipple, 1/2" x Close NPT BM
20	8104878	Check Valve 1/2" NPT 1 PSI



### 1.11 Filtration System Components cont.

ITEM	PART #	COMPONENT
21	2206190	Brace, Pump Motor
*	8071105	Heater Strip Assembly, 100-120V 25W 18"
22	8103007	Magnet, Pull Ring
23	1082218SP	Assembly, Filter Pan Switch ( <b>3, 4, and 5 Vat Fryers</b> )
	1080839SP	Assembly, Filter Pan Switch ( <b>2-Vat Fryer</b> )
√ *	1065876SP	Sensor, Magnet
24	8237468	Guard Filter Pan Lid <b>Oval (2, 3, 4, 5 Battery After 10/2018)</b>
	8237480	Guard, Pan Splash Lid <b>Oval (2-Vat Fryer Prior to 10/2018)</b>
25	2401086	Wrench, Pre-Filter Cap
26	8104167	Lanyard, Filter Screen Wrench
*	8071105	Heater Strip Assembly, 100-120V 25W 18"
*	8071098	Heater Strip Assembly, 208-250V 25W 18"

\* Not illustrated. √ Recommended parts.

### 1.11.1 Filter Motor Harnesses **(after 05/2019)**

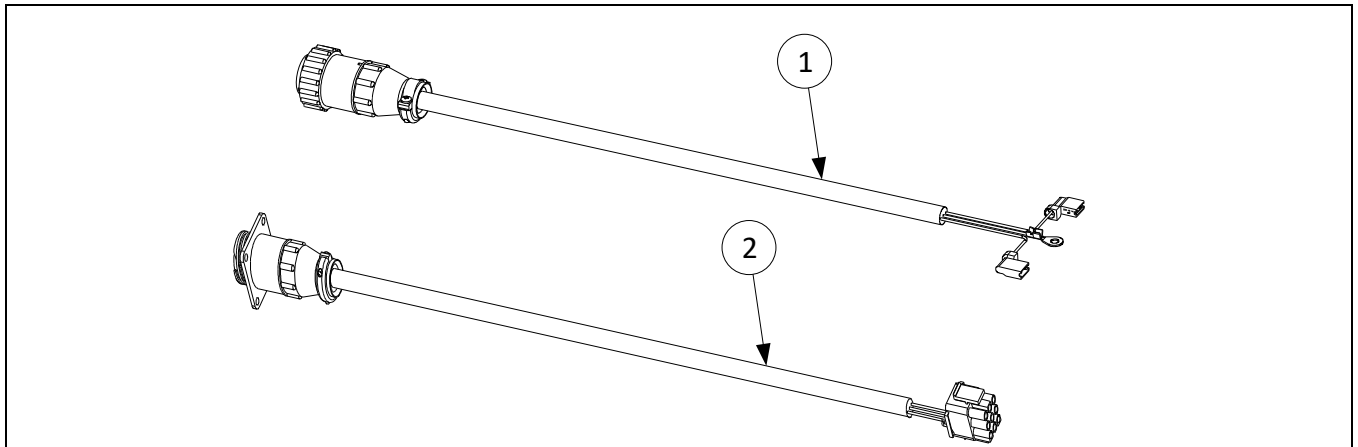

ITEM	PART #	COMPONENT
1	8076406	Harness, Filter Motor Female
2	8076407	Harness, Filter Motor Male

\* Not illustrated. ✓ Recommended parts

## 1.12 ATO (Auto Top-Off) Components

### 1.12.1 JIB Cradle and JIB Cap Assemblies

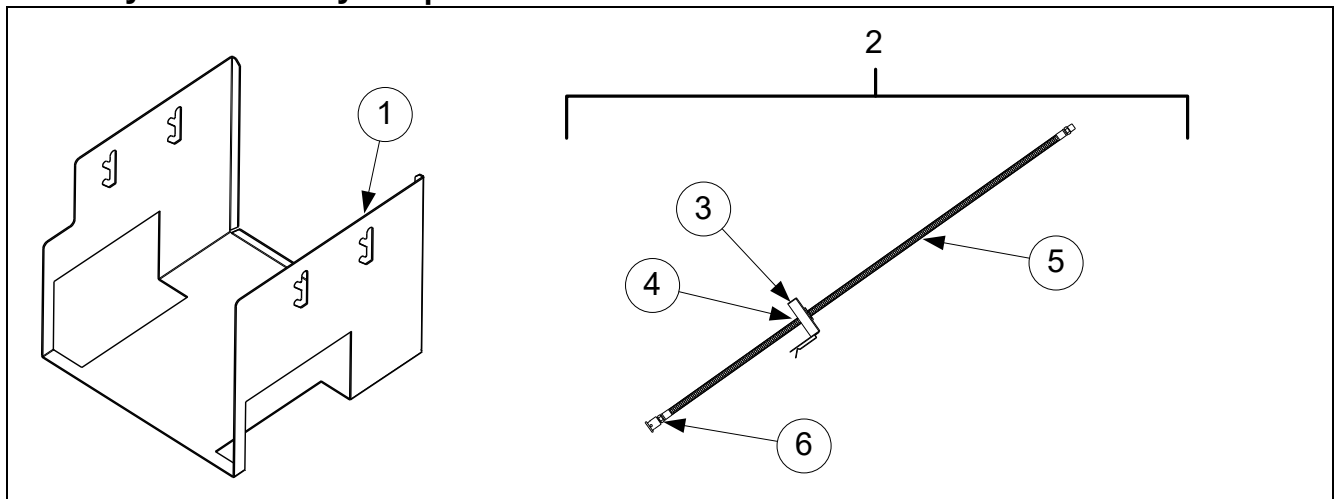

ITEM	PART #	COMPONENT
1	2208363	Cradle, JIB Gas LOV™
2	1082005SP	Cap, JIB Assembly ( <i>use 1082002SP for BIB [Europe]</i> ) ( <i>use 1087215SP Middle East</i> )
3	1082001SP	Cap, JIB ( <i>use 8239175 for BIB [Europe]</i> ) ( <i>use 8122390 Metal Cap Middle East</i> )
4	8072469	Bushing, Heyco ( <i>use 8104716 Middle East</i> )
5	8103823	Hose, JIB
6	8237738	Tip Assy ( <i>use 8238742 for BIB [Europe] and Middle East</i> )

\* Not illustrated. ✓ Recommended parts.

### 1.12.2 ATO Pump Assembly

Item 2 connects to a check valve before going into the oil return manifold.

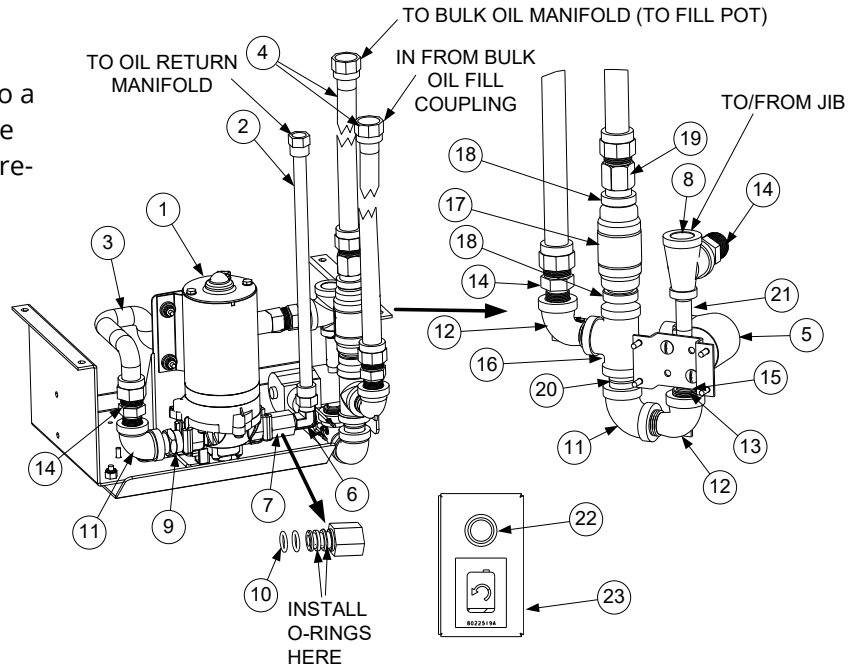

ITEM	PART #	COMPONENT
	1087704	Pump, Assy GL230 RTI ATO (use 1087702 for GL330 ATO)
√ 1	1084372	Pump, Shurflo 24VAC (use 1085673 for CE)
2	8103263	Flexline, 3/8" OD x 36" (Out to oil check valve and to return manifold)
	8103375	Flexline, 3/8" OD x 17" (Out to oil check valve and to return manifold) Two battery
*	8100667	Check valve, 1/2 NPT 1 PSI
3	8101055	Flexline, 5/8" OD x 11.50" (Inlet to Top Off Pump) Domestic units only
4	8101369	Flexline, 5/8" OD x 17.50"
5	1066830SP	Solenoid
6	8130940	Elbow, 1/4" NPT x 3/8 Flare
7	1083403	Fitting, Shurflo Pump with female end (includes O-rings)
8	8130530	Tee, Reducing 1/2" x 1/4" x 1/2" (JIB hose connects here)
9	1082054SP	Fitting, Shurflo Pump with male end (includes O-rings)
10	8160782	O-Ring, Viton #111
11	8130062	Elbow, 1/2" BM 90°
12	8130165	Elbow, Street 1/2" x 1/2" NPT 90° BM
13	8130304	Bushing, BM Flush
14	8101668	Adaptor, Male 5/8" OD x 1/2"
15	8130838	Nipple, 1/4" NPT BM Close
16	8130003	Tee, 1/2" x 1/2" x 1/2" BM
17	8103583	Check Valve 1/2" NPT 4 PSI
18	8103738	Adapter, Check Valve Close NPT
19	8101669	Adapter, Female 7/8" OD x 1/2"
20	8130022	Nipple, 1/2" x Close NPT BM
21	8130537	Nipple, 1/4" x 2.00" NPT
22	1069206	Assembly, JIB Reset Button Bracket
23	8074678	Switch, Momentary JIB Reset

\* Not illustrated. √ Recommended parts.

### 1.12.3 Shortening Melting Unit

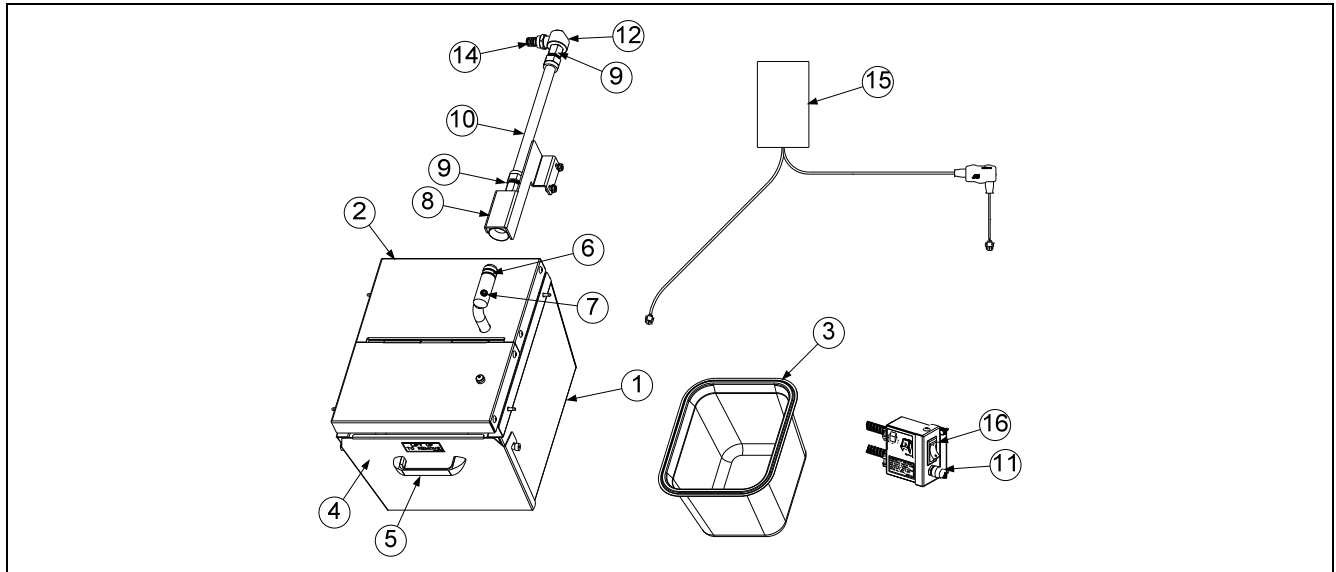

ITEM	PART #	COMPONENT
	1083406SP	Assembly, Heated Shortening
1	1082983	Box Assembly, Heated Shortening
2	1083001	Assembly, Heated Shortening Lid
3	8103957	Pan, Heated Shortening
4	1083372SP	Cover, Shortening Box Front
5	8100180	Handle
√ 6	8261392	O-Ring (Pkg. of 5)
7	8130568	Plug, 1/8" Socket Head Pipe
8	8238079	Bracket W/A, Shortening Suction 3 battery
	8238147	Bracket W/A, Shortening Suction 4 battery
9	8101669	Adaptor, Female 7/8" OD x 1/2"
10	8101055	Flexline, 5/8" OD x 11.5"
11	8071321	Holder, Fuse
√ *	8071555	Fuse 5 Amp
12	8130908	Adapter, 1/2" NPT 90°
13	8103820	Fitting, Quick Connect Shurflo Pump
14	8160782	O-Ring, Viton #111
15	8075268	Strips, Hot Box Heater with controller
16	8074036	Switch
*	8071098	Heater Strip Assembly, 240V, 25W 18"
*	8071419	Heater Strip Assembly, 240V, 45W 36"
*	8071473	Heater Strip Assembly, 240V, 70W 56"

\* Not illustrated. √ Recommended parts.

### 1.13 Bulk Oil System Components

#### 1.13.1 Bulk Oil Dispose Waste Valve

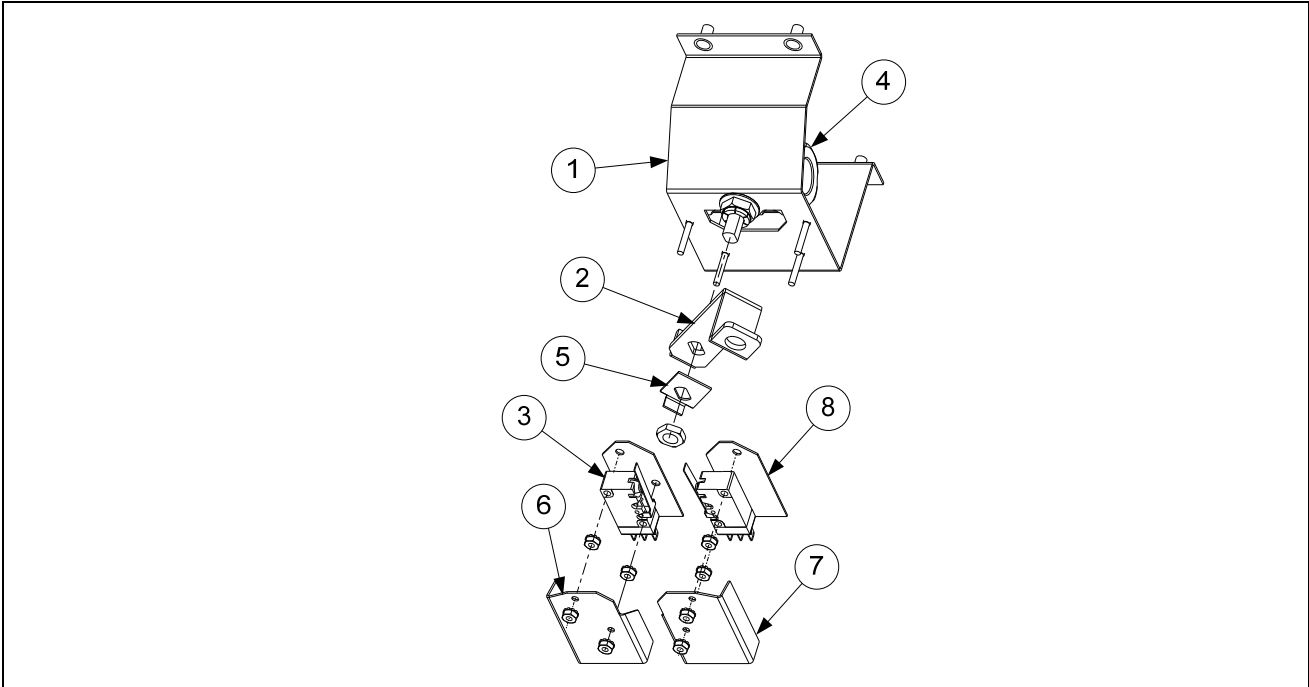

ITEM	PART #	COMPONENT
	1081433	Valve, RTI Dispose Waste (prior to 10/2018)
	1088263	Valve, RTI Dispose Waste (after to 09/2018)
1	1081437	Bracket, RTI Waste Valve (prior to 10/2018)
	1088262	Bracket, RTI Waste Valve (after to 09/2018)
2	2205899	Handle, RTI Waste Valve (prior to 10/2018)
	2401834	Handle, RTI Waste Valve (after to 09/2018)
3	8074936	Microswitch, Gold Sealed
4	8100278	Valve, 1/2" Ball
5	9002935	Retainer, Nut Return Valve
6	9012348	Cover, DV Safety Switch
7	9022348	Cover, DV Safety Switch
8	8160220	Insulation, RF Switch

### 1.13.2 Bulk Oil Manifold and Accessories

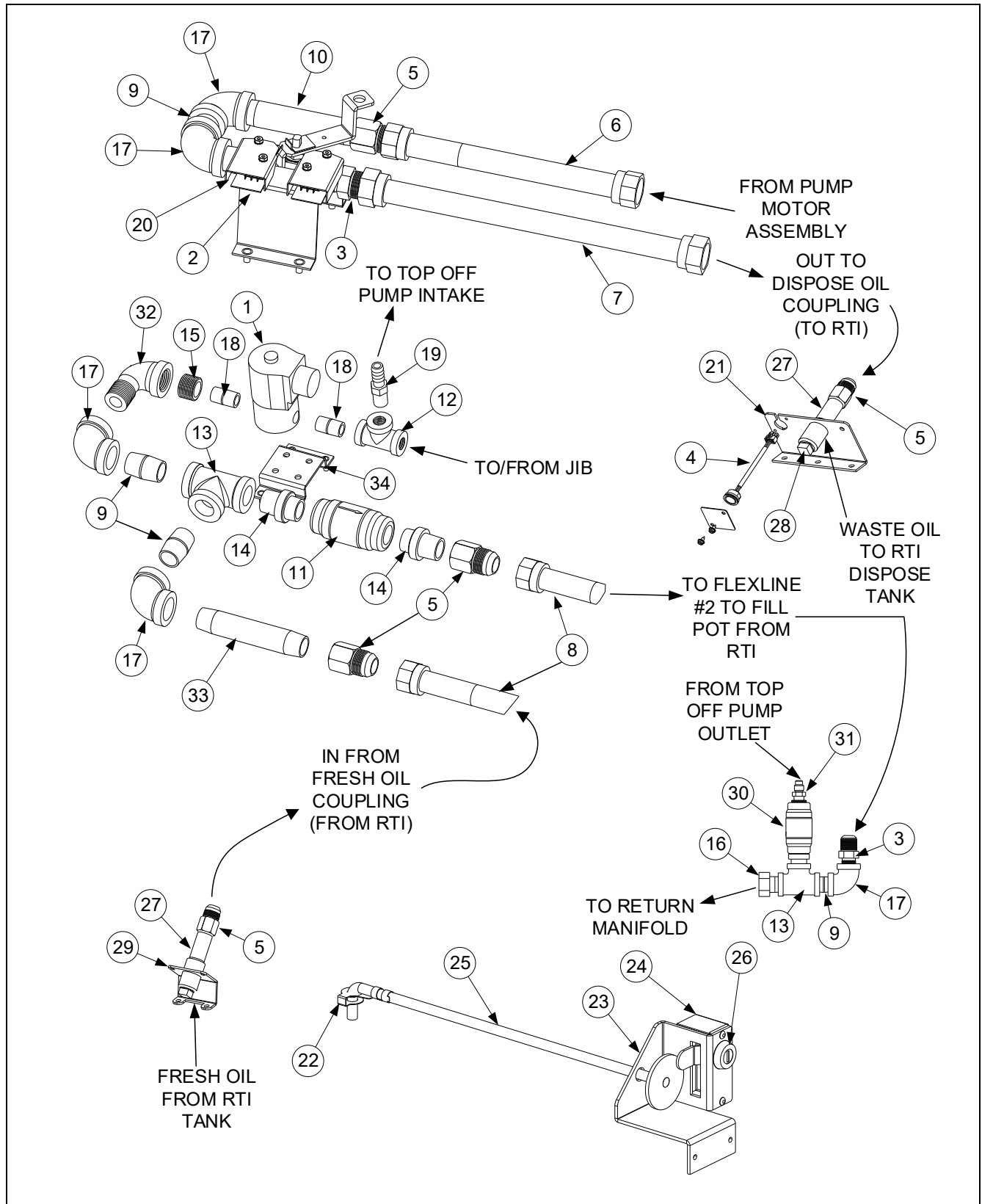

### 1.13.2 Bulk Oil Manifold and Accessories

ITEM	PART #	COMPONENT
√ 1	1066830SP	Solenoid Assembly
2	1081433	Valve, RTI Waste Assembly (see page 1-33 for parts)
3	8101668	Adaptor, Male 5/8" OD x 1/2"
4	8074760	Harness, RTI – MIB connection <b>(prior to 06/2019)</b>
*	8076413	Harness, Dispose/Pan Switch/RTI <b>(after 05/2019)</b>
5	8101669	Adaptor, Female 5/8" OD x 1/2"
6	8101067	Flexline, 5/8" OD x 8.50"es long <i>(used on 3, 4 and 5 battery units)</i>
	8101057	Flexline, 5/8" OD x 13"es long <i>(used on 2 battery units)</i>
7	8101055	Flexline, 5/8" OD x 11.50"es long
8	8101369	Flexline, 5/8" OD x 17.50"es long
9	8130022	Nipple, 1/2" x Close NPT BM
10	8130251	Nipple, 1/2" x 4.50"es NPT BM <i>(used on 3, 4 and 5 battery units)</i>
11	8103583	Valve, Check 1/2" NPT 4 PSI RTI Manifold
12	8130958	Tee, 1/4" NPT BM
13	8130003	Tee, 1/2" x 1/2" x 1/2" BM
14	8103738	Adaptor, Check Valve Close Nipple
15	8130304	Bushing, 1/2" x 1/4"
16	8103160	Adaptor, 1/2" NPT x 15/16"
17	8130062	Elbow, 1/2" BM 90°
18	8130838	Nipple, 1/4" NPT
19	8160708	Fitting, 1/4" NPT Male Barb
20	8130298	Nipple, 1/2" x 2"es NPT BM
21	8237863	Bracket W/A, Gas LOV™ RTI Dispose <b>(prior to 06/2019)</b>
*	8238494	Bracket W/A, RTI Dispose <b>(after 05/2019)</b>
	1080686SP	Handle and Lock Assy, Gas LOV™ RTI
22	8090657	Clip, Clevis Right Rod End
23	2205656	Brace, RTI Handle
24	2205657	Cover, RTI Handle
25	8237208	Handle, Gas LOV™ RTI Waste Pull
26	8103587	Lock, RTI Waste Handle (includes keys)
27	8130265	Nipple, 1/2" x 2.50"es NPT BM <b>(use item #7 after 05/2019)</b>
28	8130336	Plug, 1/2" NPT SQ HD SS <b>(prior to 06/2019)</b>
*	8130463	Plug, Pipe 1/2" NPT <b>(after 05/2019)</b>
29	8237838	Bracket W/A, Gas LOV™ RTI Fresh Oil
30	8100667	Valve, Check 1/2" NPT 1 PSI RTI Manifold
31	8103270	Fitting, 3/8" Flare x 1/4" NPT
32	8130165	Elbow, ST 1/2" NPT 90° BM
33	8130093	Nipple, 1/2" x 4"es NPT BM
34	1082192	Stud Assy, GL Solenoid Bracket

√ Recommended parts.

### 1.13.3 Japan Itto Can Dispose Components

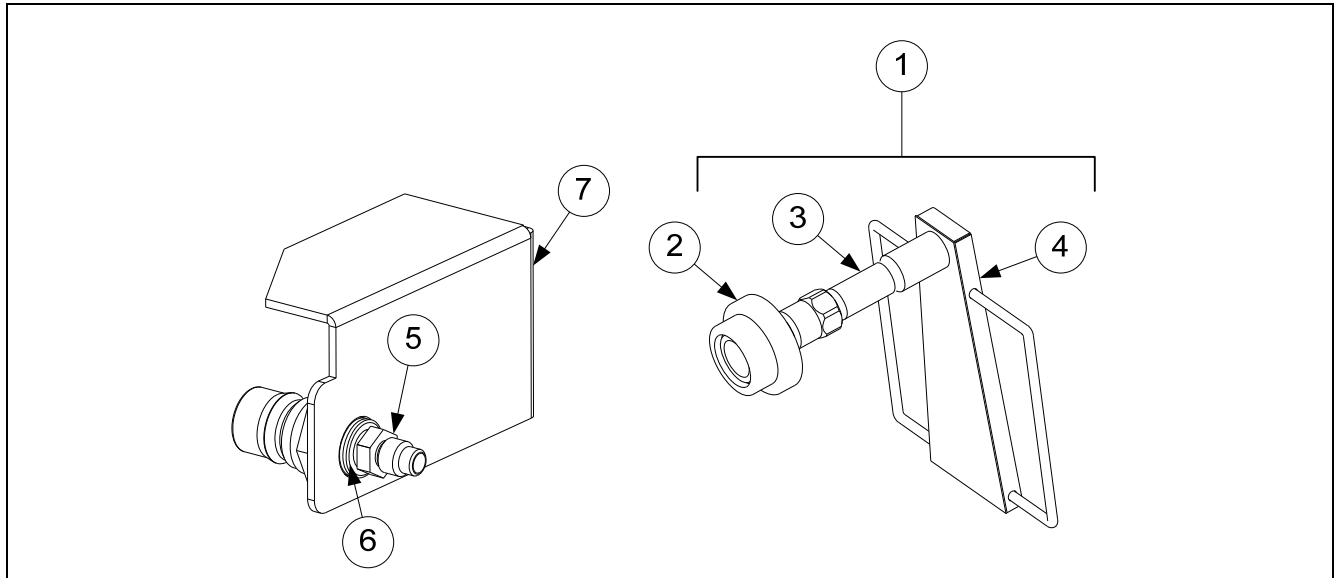

ITEM	PART #	COMPONENT
1	1086183	Faucet, Itto Can Dispose Assembly
2	8100490	Quick Disconnect ½" Female
3	8130460	Nipple, ½" x 3.00" NPT BM Pipe
4	8238988	Faucet, Itto Can Dispose
5	8103270	Fitting, ⅜" Flare x ¼" NPT
*	8130940	Elbow, ⅜" Flare x ¼" NPT ( <i>after 04/30/2020</i> )
6	8130304	Bushing, ½" x ¼"
7	8239008	Mount, Front Dispose
*	8239648	Mount, Front Dispose ( <i>after 04/30/2020</i> )

\* Not illustrated. ✓ Recommended parts.



## 1.14 Oil Quality Sensor (OQS) and Associated Parts

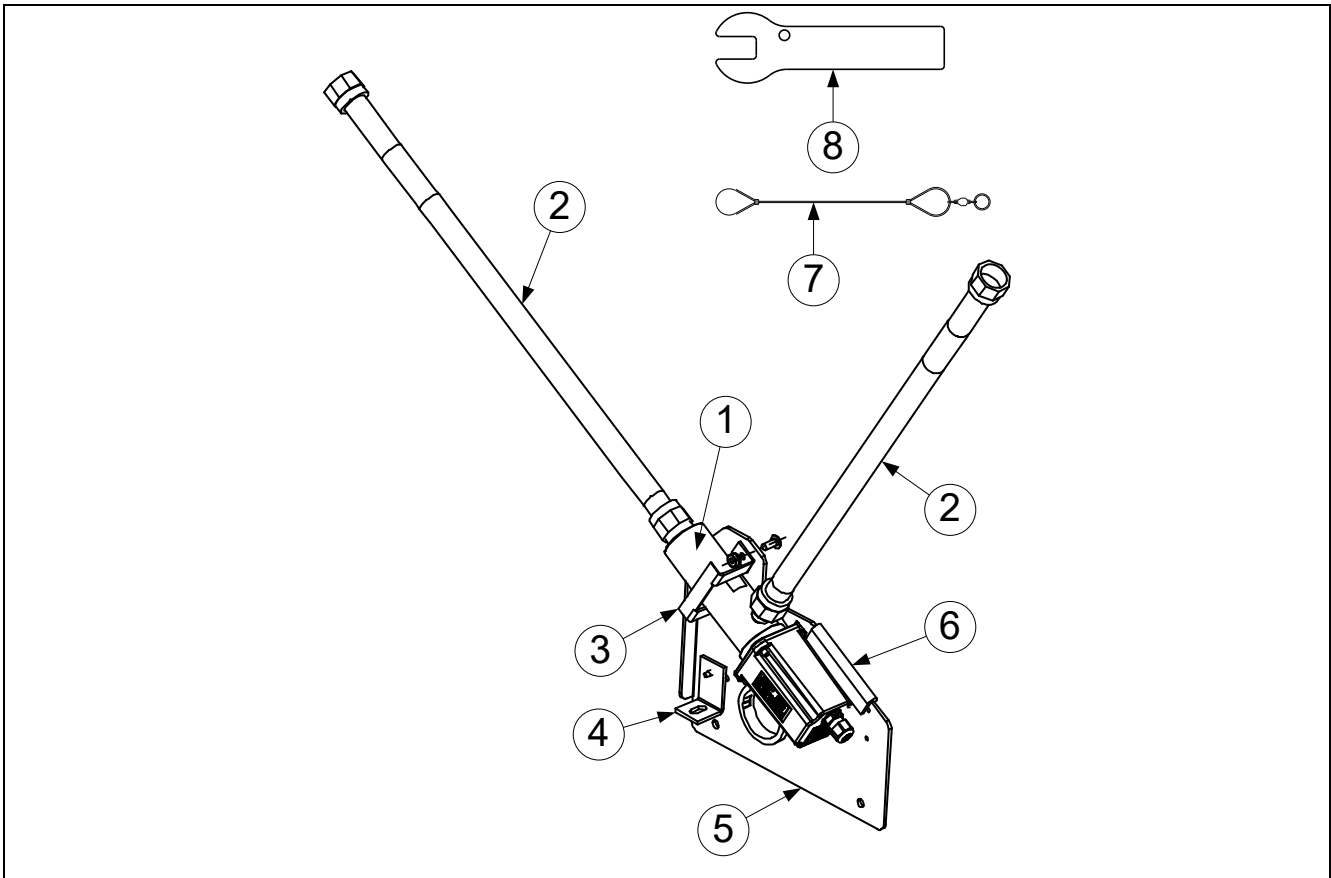

ITEM	PART #	COMPONENT
	8263566	Kit, OQS FilterQuick Gas 2-Battery (Kit to add to existing LOV-T Gas Fryers)
	8263565	Kit, OQS FilterQuick Gas 3/4/5 Battery (Kit to add to existing LOV-T Gas Fryers)
1	8263292	Sensor, FilterQuick OQS Replacement
2	8101369	Flexline, 5/8" OD x 17.50"
*	8101057	Flexline, 5/8" OD x 13.00"
*	8101400	Flexline, 5/8" OD x 21.00"
3	2401385	Retainer, OQS Sensor <b>(prior to 06/2019)</b>
*	2401910	Retainer, OQS Sensor <b>(after 05/2019)</b>
4	2401386	Brace, OQS Sensor Mount
5	2401438	Mount, OQS Sensor <b>(prior to 06/2019)</b>
*	1088338	Mount, OQS Sensor <b>(after 05/2019)</b>
6	8122524	Insulation
7	8104167	Lanyard, In-Line Filter
8	2401086	Wrench, Pre-Filter Cap
*	8238990	Wrench, 1-1/16" (27mm)
*	8238991	Wrench, 1-1/16" (27mm) crows foot

# 1.15 BIGLA30-T Series Simplified Wiring

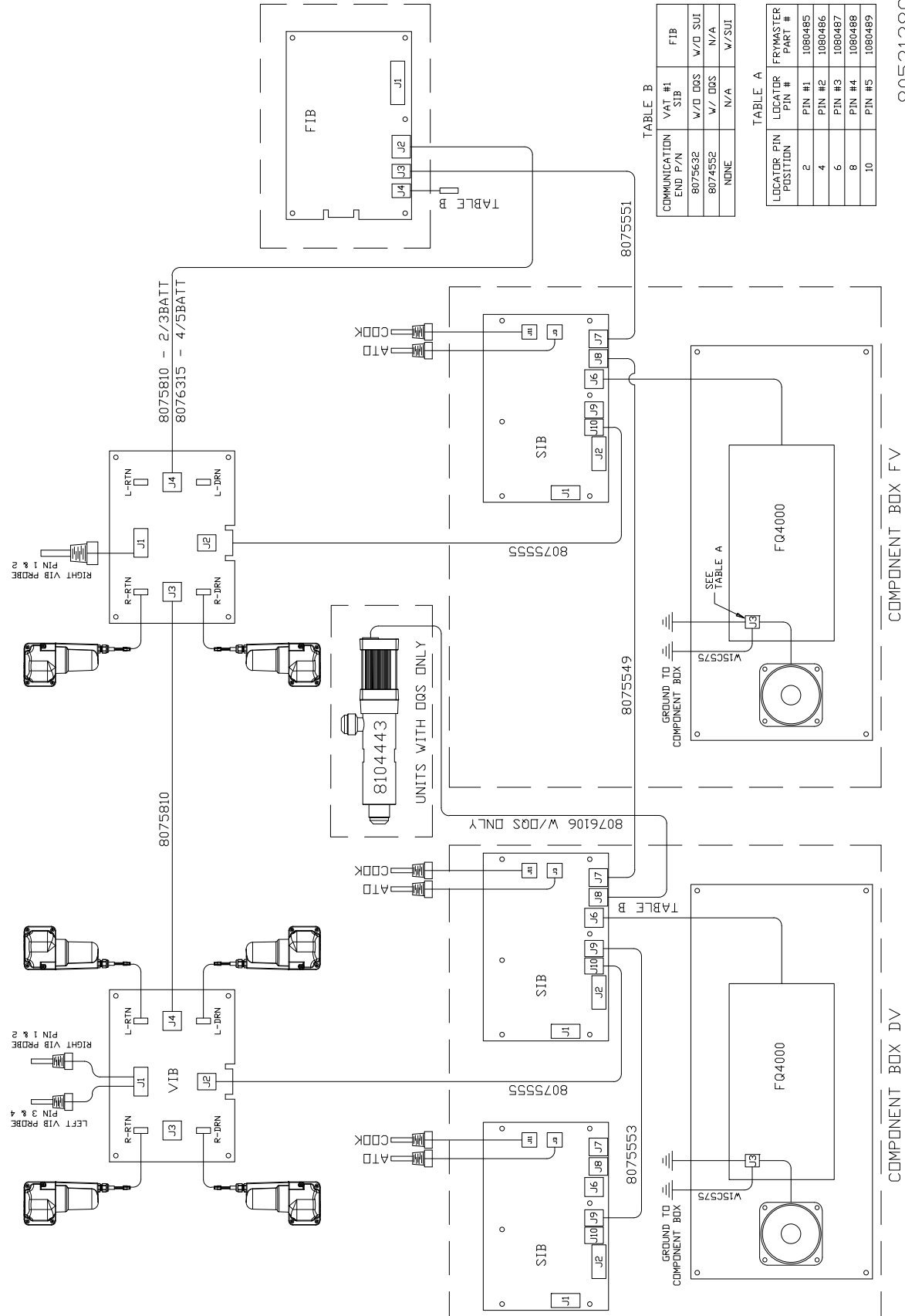

TABLE B

COMMUNICATION END P/N	VAT #1 SIB	FTB
8075632	W/D DQS	W/D SUI
8074552	W/ DQS	N/A
NONE	N/A	W/SUI

TABLE A

LOCATOR PIN POSITION	LOCATOR PIN #	FRYMASTER PART #
2	PIN #1	1080485
4	PIN #2	1080486
6	PIN #3	1080487
8	PIN #4	1080488
10	PIN #5	1080489

8052138C

**THIS PAGE INTENTIONALLY LEFT BLANK**

©2025 Frymaster LLC. except where explicitly stated otherwise. All rights reserved. Continuing product improvement may necessitate change of specifications without notice.

Part Number FRY\_P\_8197544 03/2025

