

Frymaster[®]

We Fit the Way You Fry[™]

FQE60U FilterQuick[™] easyTouch[®] Electric Fryer

Wiring Diagrams

This manual is updated as new information and models are released. Visit our website for the latest manual.



Keep these wiring diagrams with the fryer for future reference.



Part Number: FRY_D_8197625 02/2025

Original Instructions



WELBILT
an Ali Group Company

FQE60U FILTERQUICK™ easyTouch® SERIES ELECTRIC FRYER
Table of Contents

Chapter 1: Wiring Diagrams

1.1	Control Wiring	1-1
1.2	Contactor Box – Delta Configuration (<i>1-Heat, 1-Latch Construction</i>).....	1-2
1.2.1	Contactor Box – Delta Configuration (<i>2-Heat, 1-Latch Construction</i>).....	1-3
1.3	Contactor Box – WYE Configuration	1-4
1.4	Basket Lift Wiring 200V-250V – (<i>After Jan. 2013</i>) (<i>Modular</i>)	1-5

1.2 Contactor Box - Delta Configuration (1-Heat, 1-Latch Construction)

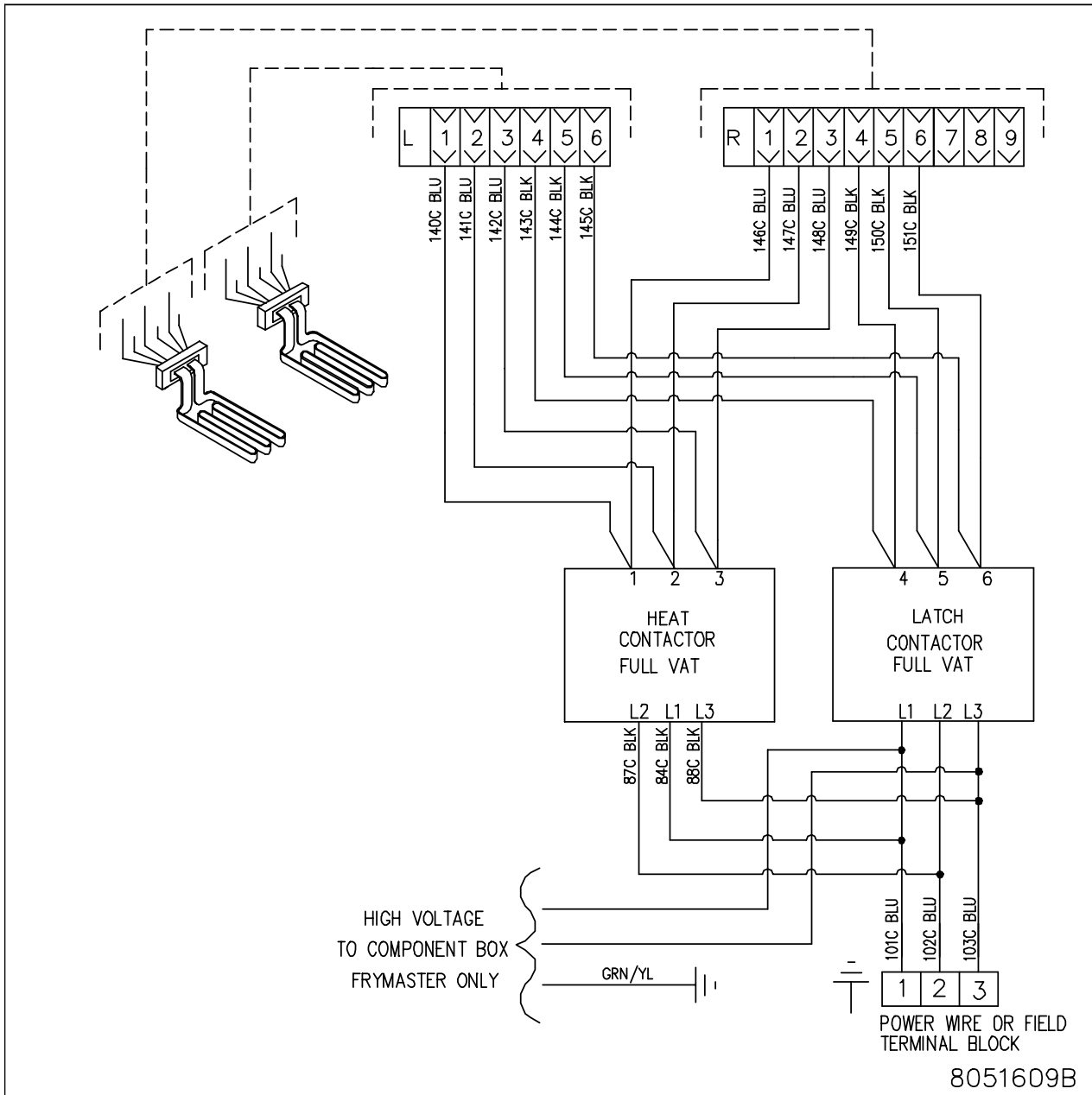

1.2.1 Contactor Box - Delta Configuration (2-Heat, 1-Latch Construction)

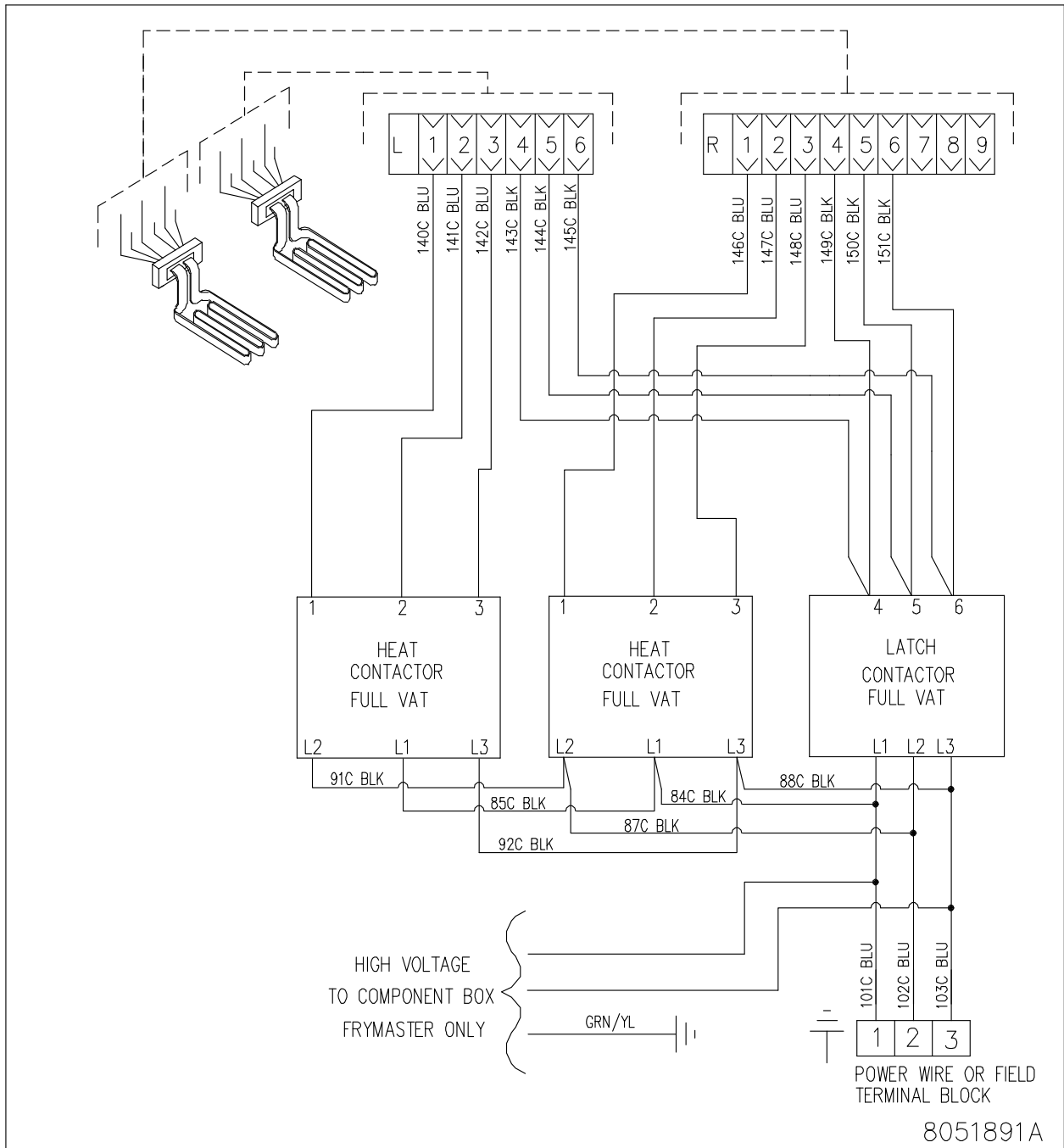

1.3 Contactor Box - WYE Configuration

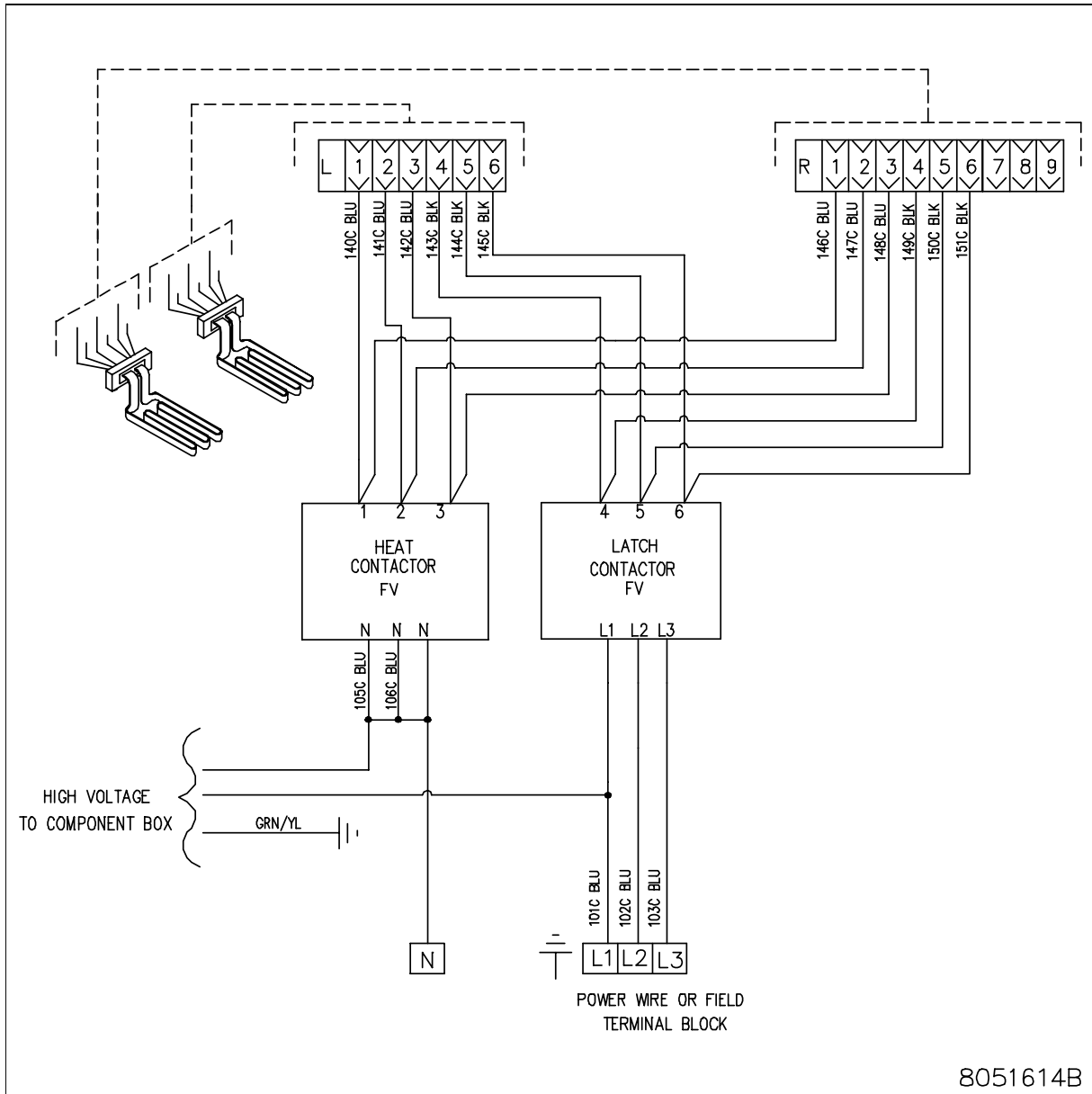

8051614B

1.4 Basket Lift Wiring 200V-250V - After Jan. 2013 (Modular)

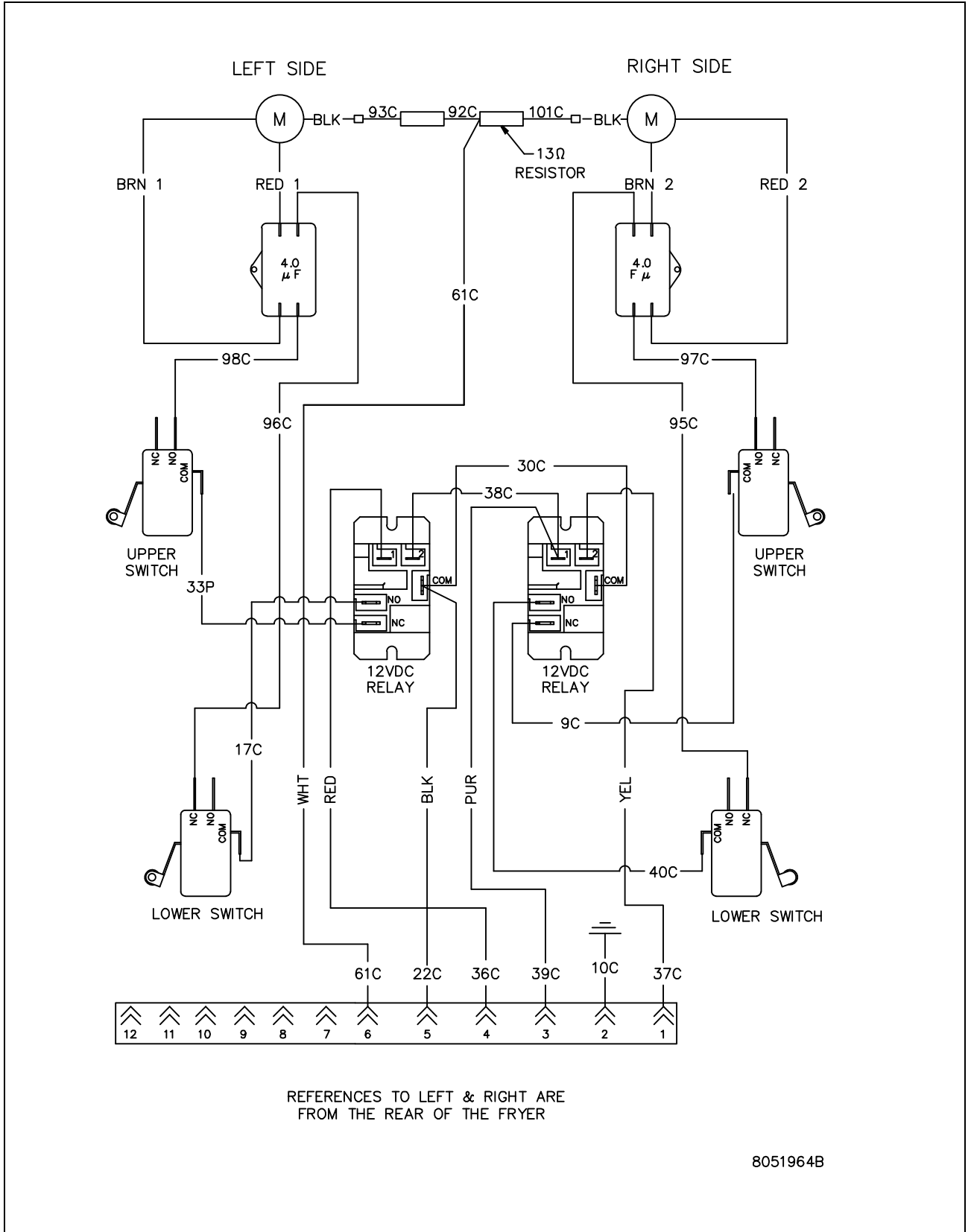



FRYMASTER
8700 LINE AVENUE, SHREVEPORT, LA 71106-6800

800-551-8633
318-865-1711

WWW.FRYMASTER.COM

EMAIL: FRYSERVICE@FRYMASTER.COM

©2025 Frymaster LLC. except where explicitly stated otherwise. All rights reserved. Continuing product improvement may necessitate change of specifications without notice.

Part Number FRY_D_8197625 02/2025

