

## FilterQuick™ FQG60T easyTouch® Gas Fryer

### Parts Manual

This manual is updated as new information and models are released. Visit our website for the latest manual.



8 1 9 7 9 1 8  
Part Number: FRY\_P\_8197918 04/2025

**NOTICE**

**IF, DURING THE WARRANTY PERIOD, THE CUSTOMER USES A PART FOR THIS FRYMASTER DEAN EQUIPMENT OTHER THAN AN UNMODIFIED NEW OR RECYCLED PART PURCHASED DIRECTLY FROM FRYMASTER DEAN, OR ANY OF ITS FACTORY AUTHORIZED SERVICERS, AND/OR THE PART BEING USED IS MODIFIED FROM ITS ORIGINAL CONFIGURATION, THIS WARRANTY WILL BE VOID. FURTHER, FRYMASTER DEAN AND ITS AFFILIATES WILL NOT BE LIABLE FOR ANY CLAIMS, DAMAGES OR EXPENSES INCURRED BY THE CUSTOMER WHICH ARISE DIRECTLY OR INDIRECTLY, IN WHOLE OR IN PART, DUE TO THE INSTALLATION OF ANY MODIFIED PART AND/OR PART RECEIVED FROM AN UNAUTHORIZED SERVICER.**

**FQG60T easyTouch® FILTERQUICK™ SERIES GAS FRYERS**  
**PARTS MANUAL**  
**TABLE OF CONTENTS**

**CHAPTER 1: Parts List**

1.1	Accessories .....	1-1
1.2	Doors, Sides, Flue Caps, Top Caps and Casters.....	1-2
1.3	Control Panel Frame Assemblies.....	1-3
1.4	Drain Tube Sections and Associated Parts.....	1-4
1.5	Electronics and Electrical Components .....	1-5
1.5.1	Component Boxes and Associated Parts .....	1-5
1.5.2	Transformer Boxes.....	1-7
1.5.3	VIB (Valve Interface Board) Components .....	1-8
1.5.4	Power Reset Switch and USB Connector .....	1-8
1.6	Wiring.....	1-9
1.6.1	Wiring Harness SIB to Rear of Component Box (Spark to Pilot) .....	1-9
1.6.2	Wiring Harness FIB, Power, Filter, ATO, Bulk .....	1-10
1.6.3	Wiring Harness Filter, ATO, Power, CTL.....	1-10
1.6.4	Wiring Harness Power, Float, VIB, Gas.....	1-11
1.6.5	Wiring Harness Dispose, Pan Switch .....	1-11
1.6.5.1	Wiring Harness Dispose, Pan Switch .....	1-12
1.6.5.2	Wiring Harness, Pan Switch.....	1-12
1.6.6	Wiring Harness Dispose, Pan Switch, Bulk.....	1-13
1.6.7	Miscellaneous Wiring Harnesses and Cord Sets .....	1-13
1.7	Frypots and Associated Components .....	1-14
1.7.1	Frypot Components .....	1-14
1.7.2	Frypot Assemblies and Associated Parts.....	1-16
1.8	Oil Return Manifolds .....	1-17
1.9	Gas Supply and Combustion System Components .....	1-17
1.10	Filtration System Components .....	1-19
1.10.1	Filter Pan and Accessories.....	1-19
1.10.1.1	MasterFil Filter Pan and Accessories .....	1-20
1.10.2	Filter Pump and Accessories (1FQG60T) .....	1-21
1.10.3	Filter Pump and Accessories (2FQG60T, 3FQG60T) .....	1-23
1.10.4	Plumbing (1FQG60T) – No ATO with Front Dispose.....	1-25
1.10.5	Plumbing (1FQG60T) – Bulk.....	1-26
1.10.6	Plumbing (2FQG60T, 3FQG60T) – Bulk .....	1-28
1.11	ATO (Automatic Top-Off) Components.....	1-29
1.11.1	Side Saddle Assembly .....	1-29
1.11.2	ATO Pump Assembly (1FQG60T) .....	1-30
1.11.3	ATO Pump Assembly with Bulk (2FQG60T, 3FQG60T).....	1-31
1.12	Bulk Oil System Components .....	1-32
1.12.1	Bulk Oil Dispose Waste Valve.....	1-32
1.12.2	Bulk Connection – Rear ( <i>Prior to 03/2025</i> ) .....	1-33
1.12.2.1	Bulk Connection – Rear ( <i>After to 02/2025</i> ) .....	1-33
1.12.3	Bulk Connection - Front.....	1-34
1.13	Basket Lift Assembly and Associated Parts.....	1-35
1.13.1	Basket Lift Assembly and Associated Parts ( <i>June 2012 to June 2013</i> ).....	1-35
1.13.2	Basket Lift Assembly and Associated Parts – 120V – ( <i>After June 2013</i> ) ( <i>Modular</i> ) ....	1-37
1.14	FilterQuick™ FQG60T Series Wiring.....	1-39

# FQG60T easyTouch® FILTERQUICK™ SERIES GAS FRYERS

## PARTS LIST

### 1.1 Accessories

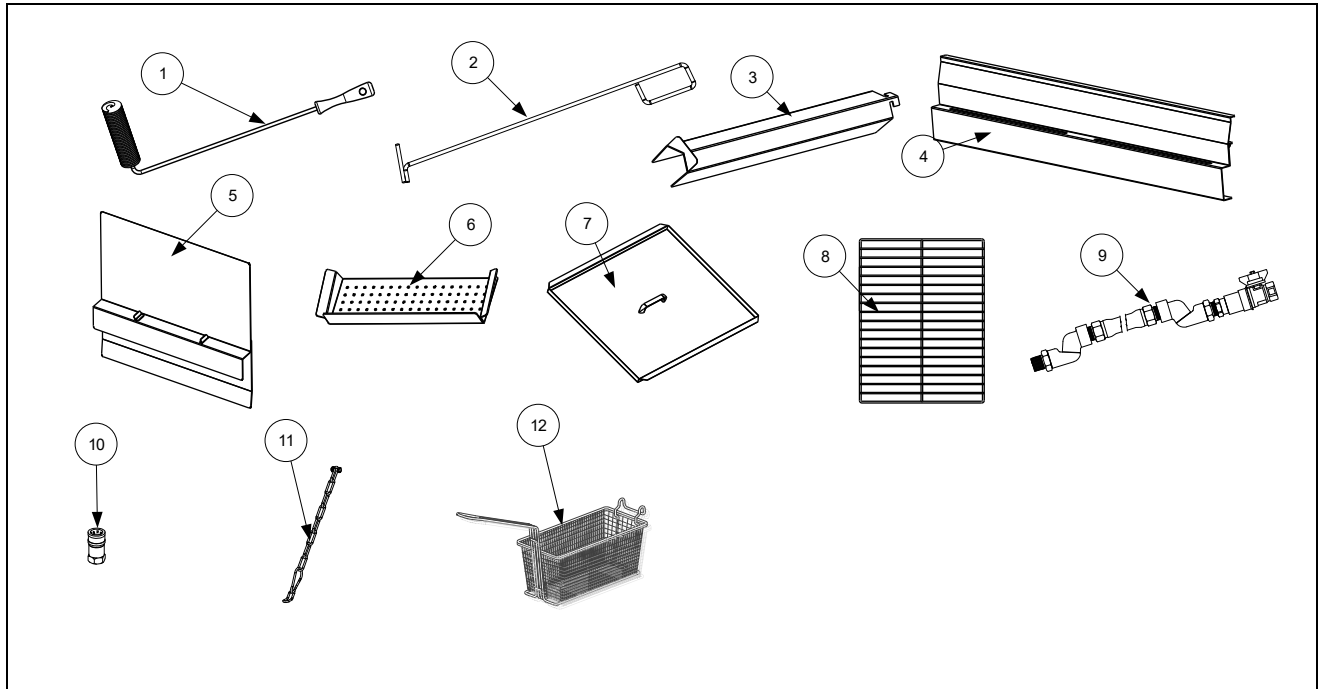

ITEM	PART #	COMPONENT
1	8030278	BRUSH, FRYPOT
2	8030388	FRYERS FRIEND
3	8236908	CONNECTING STRIP, FRYPOT (2FQG60, 3FQG60)
4	8237770	HANGER, BASKET (1FQG60)
	8237771	HANGER, BASKET (2FQG60)
	8238740	HANGER, BASKET (3FQG60)
5	8239601	SHIELD, SPLASH BANGER
6	2600623	INSERT, FOAM DECK (BANGER)
7	1081872	COVER, FRYPOT
8	8030380	BASKET SUPPORT RACK
9	8102734	GAS LINE, 3/4" X 48" WITH QUICK DISCONNECT
10	8103745	QUICK DISCONNECT FITTINGS, 3/4" SET (INCLUDES MALE AND FEMALE CONNECTORS)
11	8260900	KIT, CHAIN RESTRAINT
*	8261095	KIT, ANCHOR STRAP
12	8030357	BASKET, TRIPLE SIZE 4.50" WIDE X 6" TALL
	8030271	BASKET, TWIN SIZE 5.89" WIDE X 5.50" TALL
	8030437	BASKET, DUAL SIZE 7.94" WIDE X 7" TALL
*	8030002	POWDER, FILTER (80- 1-CUP APPLICATIONS)
*	8030289	PACK, 100-SHEET FILTER PAPER 22" X 34"

\* Not illustrated.

## 1.2 Doors, Sides, Flue Caps, Top Caps and Casters

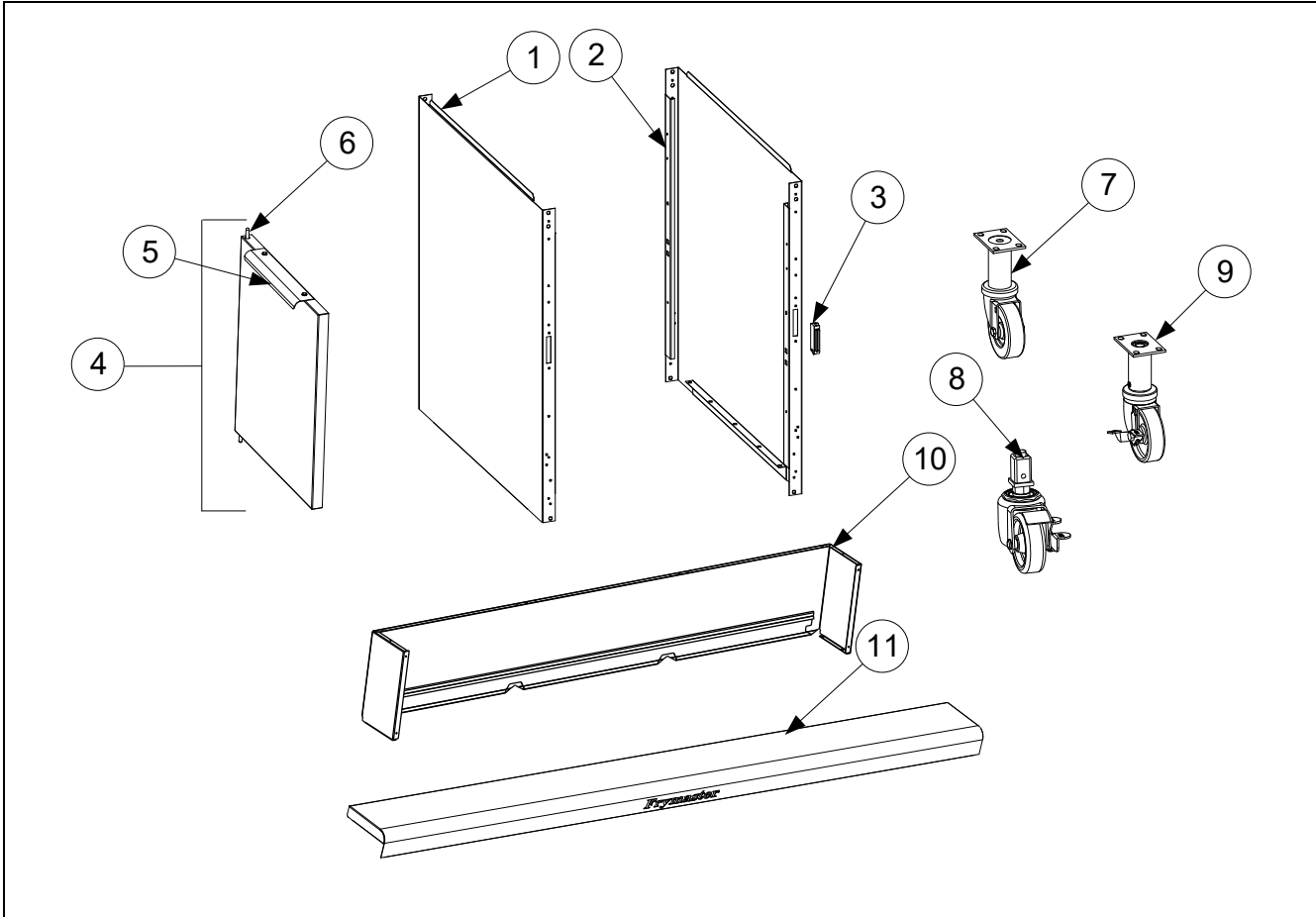

ITEM	PART #	COMPONENT
1	2601620	SIDE, CABINET LEFT (1FQG60)
	2318144	SIDE, CABINET LEFT (2FQG60, 3FQG60)
2	2601621	SIDE, CABINET RIGHT (1FQG60)
	2328144	SIDE, CABINET RIGHT (2FQG60, 3FQG60)
3	8101105	MAGNET, DOOR
4	1087173	DOOR, (1FQG60)
	1084174	DOOR, (2FQG60, 3FQG60)
5	2108077	HANDLE, DOOR
6	1064067	PIN ASSEMBLY, DOOR
*	8100275	SPRING, DOOR PIN
*	8100658	RETAINING RING
*	2307192	HINGE, DOOR LOWER (2FQG60, 3FQG60)
*	8121328	HINGE, DOOR LOWER (1FQG60)
7	8101367	CASTER, REAR, 3" WITHOUT BRAKE (1FQG60)
8	8232844	CASTER, FRONT 3" WITH BRAKE (1FQG60)
9	8102280	CASTER, 3" WITH BRAKE (2FQG60, 3FQG60)
10		FLUE CAP-STAINLESS STEEL
	2308800	1FQG60
	2306705	2FQG60
	130020101	2FQG60 W/BUTTONS
	2600529	3FQG60
	130020103	3FQG60 W/BUTTONS
11		TOP CAP
	1088620	1FQG60
	1088423	2FQG60
	1088568	3FQG60

\* Not illustrated.

### 1.3 Control Panel Frame Assemblies

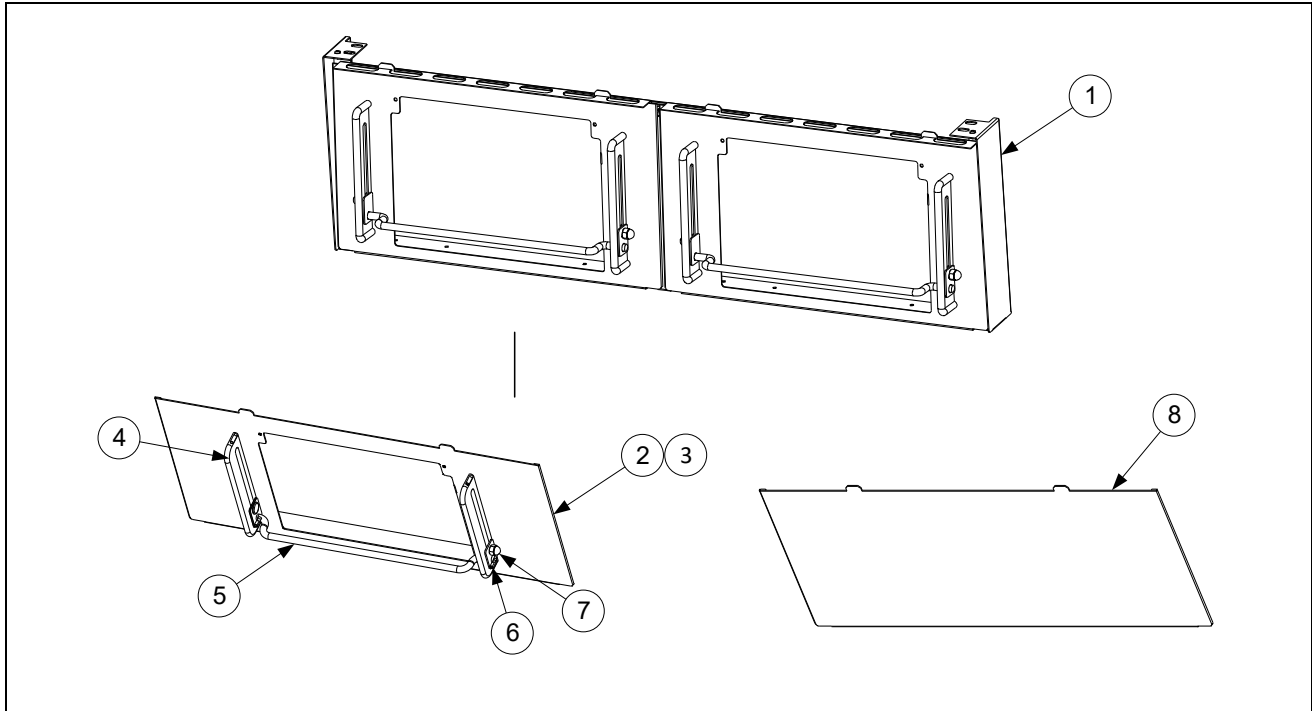

ITEM	PART #	COMPONENT
1	1087819	FRAME ASSEMBLY, CONTROL (1FQG60)
	1088348	FRAME ASSEMBLY, CONTROL (2FQG60)
	1088357	FRAME ASSEMBLY, CONTROL (3FQG60)
2	1088358	BEZEL ASSEMBLY, CONTROL FQ60
3	2602074	BEZEL, S1814 SINGLE TOUCHSCREEN
4	8104898	GUIDE, UIB ADJUSTABLE GUARD
5	8104899	BAR, GUARD (TOUCH SCREEN PROTECTION)
6	8104714	PLATE, OUTSIDE TIGHTENING
7	8090047	NUT, CAP ¼-20
8	130001487	BEZEL, SPREADER FQ60

## 1.4 Drain Tube Sections and Associated Parts

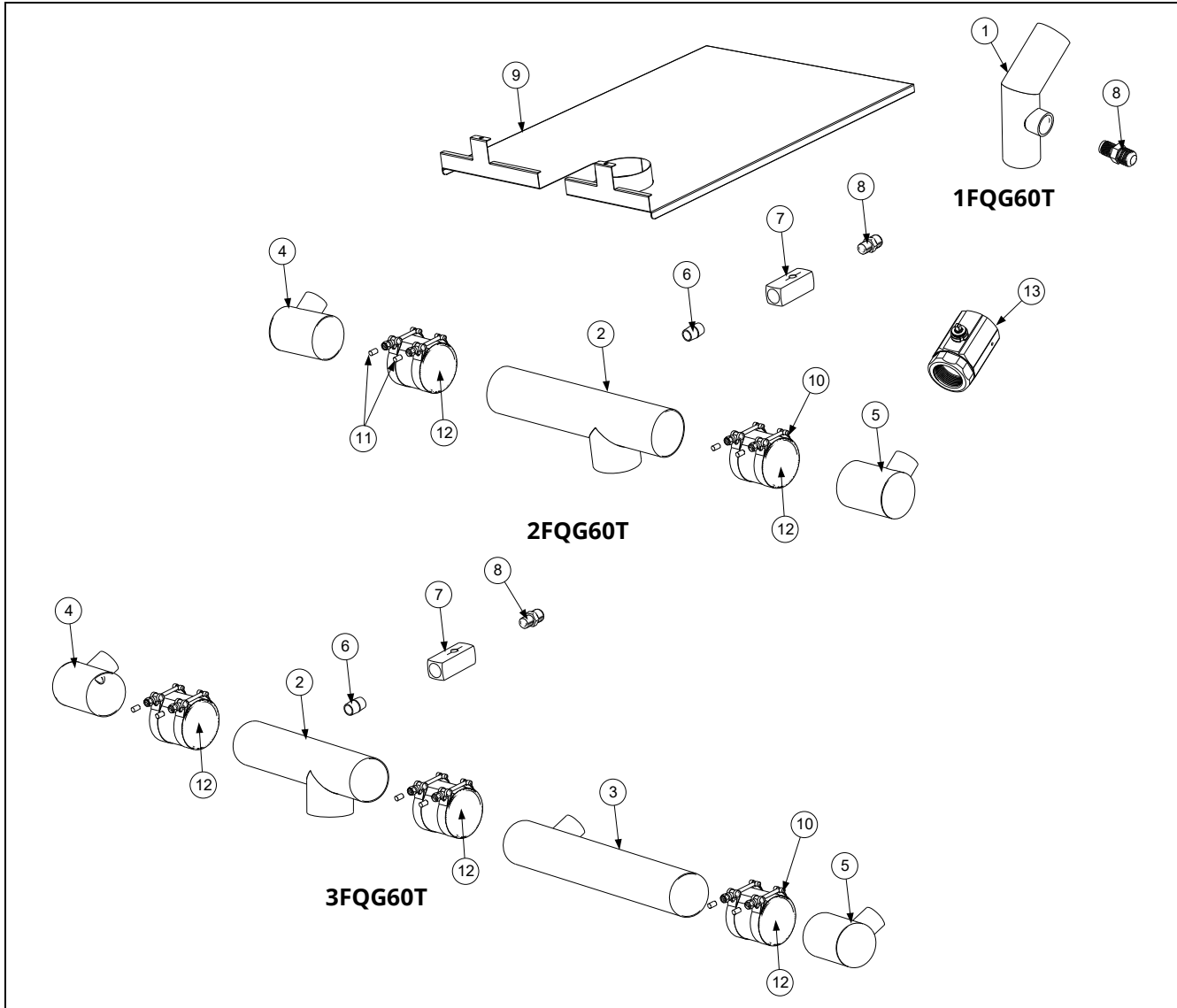

ITEM	PART #	COMPONENT
1	8239250	TUBE, DRAIN DOWNSPOUT FQ1814G <b>1FQG60</b>
2	8239331	DRAIN W/A, FQ1814G DOWNSPOUT <b>2FQG60, 3FQG60</b>
3	8237664	TUBE W/A,BK60/50/60 RH DRAIN <b>3FQG60</b>
4	8237452	TUBE W/A,BK 3" DRAIN CONN ( <b>LEFT SIDE CONNECTOR</b> ) <b>2FQG60, 3FQG60</b>
5	8237633	TUBE W/A,BK RH CONNECTN 3" DRN ( <b>RIGHT SIDE CONNECTOR</b> ) <b>2FQG60, 3FQG60</b>
6	8130022	NIPPLE, ½" X CLOSE NPT
7	8103531	VALVE, CHECK 20PSI (8105084 ALTERNATIVE REPLACEMENT)
8	8101668	ADAPTOR, MALE ⅝" OD X ½"
9	8239253	LID, FILTER PAN FQ1814G <b>1FQG60</b>
	8239339	LID W/A, FQ1814G FILTER PAN <b>2FQG60, 3FQG60</b>
10	8091095	CLAMP
11	8160665	VINYL CAP
12	8160772	SLEEVE, DRAIN CONNECTOR
13	8263817	VALVE, DRAIN 1½" NPT KIT (INCLUDES 8160544 O-RING)
*	8160544	O-RING SEAL - DRAIN

## 1.5 Electronics and Electrical Components

### 1.5.1 Component Boxes and Associated Components

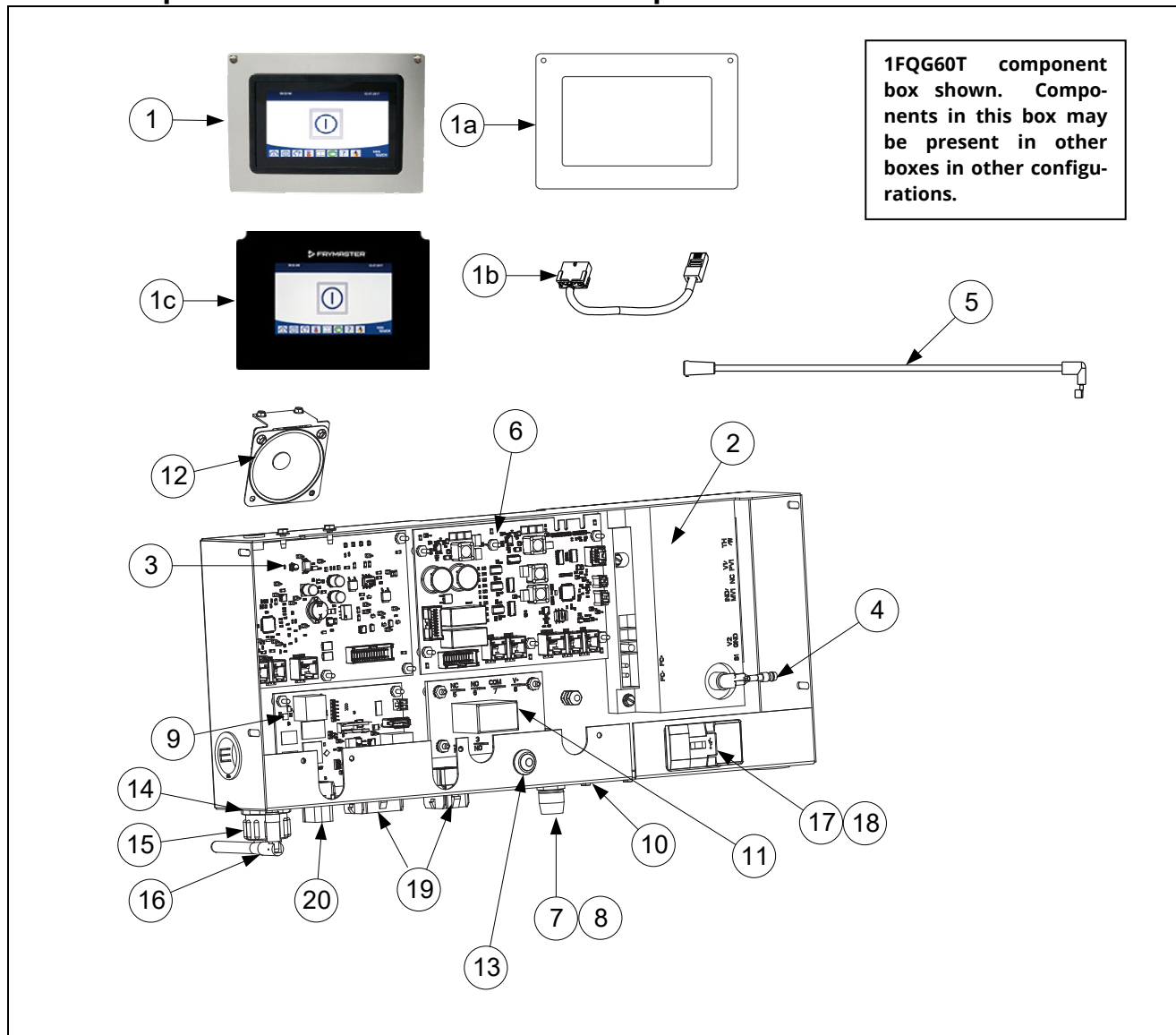

ITEM	PART #	COMPONENT
√ 1	1089411SP	CONTROLLER, FQ4000 FQG60T CHICK-FIL-A (for fryers manufactured 09/2022 to Present)
	1089407SP	CONTROLLER, FQ4000 FQG60T GENERAL MARKET (for fryers manufactured 09/2022 to Present)
	1089412SP	CONTROLLER, FQ4000 FQG60T SWISS CHALET (for fryers manufactured 09/2022 to Present)
	1089416SP	CONTROLLER, FQ4000 FQG60T ORIGINAL JOE'S (for fryers manufactured 09/2022 to Present)
	1089417SP	CONTROLLER, FQ4000 FQG60T BUFFALO WILD WINGS (for fryers manufactured 09/2022 to Present)
	1089551SP	CONTROLLER, FQ4000 FQG60T DAVE & BUSTER'S (for fryers manufactured 09/2022 to Present)
	1089414SP	CONTROLLER, FQ4000 FQG60T ST. HUBERT (for fryers manufactured 09/2022 to Present)
	1089456SP	CONTROLLER, FQ4000 FQG60T SWISS HARVEY (for fryers manufactured 09/2022 to Present)
1a	130000329	BEZEL, COMMON UI (Metal Bezel only)
1b	8076596	4000 XFER CABLE (Connects Common UI Controller to SIB Board)
√ 1c	1088860SP	CONTROLLER, FQ4000 FQG60T CHICK-FIL-A (for fryers manufactured prior to 09/2022)
	1088525SP	CONTROLLER, FQ4000 FQG60T GENERAL MARKET (for fryers manufactured prior to 09/2022)
	1088892SP	CONTROLLER, FQ4000 FQG60T SWISS CHALET (for fryers manufactured prior to 09/2022)
	1089093SP	CONTROLLER, FQ4000 FQG60T ORIGINAL JOE'S (for fryers manufactured prior to 09/2022)
	1089208SP	CONTROLLER, FQ4000 FQG60T BUFFALO WILD WINGS (for fryers manufactured prior to 09/2022)
	1089055SP	CONTROLLER, FQ4000 FQG60T ST. HUBERT (for fryers manufactured prior to 09/2022)



	1089090SP	CONTROLLER, FQ4000 <b>FQG60T SWISS HARVEY (for fryers manufactured prior to 09/2022)</b>
√ 2	8075991	MODULE, IGNITION FENWAL STP W/ ALARM
*	130197410	MODULE, IGNITION FENWAL STP (LOCAL SENSE)
√ 3	1087513SP	BOARD, FIB W/ SOFTWARE
4	8073484	CONNECTOR, RAJAH
√ 5	1067535	CABLE, IGNITION 31-INCH
√ 6	1087511SP	BOARD, INTERFACE SIB (SMART INTERFACE BOARD)
√ 7	8071321	FUSE HOLDER
√ 8	8075570	FUSE 3.5A 250V
√ 9	8076148	BOARD, FQ4000 KCCM <b>(SUI)</b>
10	8071926	BUSHING, .875 SPLIT
√ 11	8076402	BOARD, 3.5-SECOND TIME DELAY RELAY 24VDC
√ 12	8075829	SPEAKER 4 OHM
√ 13	8074678	SWITCH, MOMENTARY <b>(TOPOFF OIL RESET BUTTON)</b>
√ *	8105076	LANYARD, CONTROLLER RESTRAINT <b>(USE 1088791 FOR LANYARD W/ VAT ID CONNECTOR)</b>
14	8075967	COUPLER, 8P8C TO 8P8C
15	8075970	CAP, DUST
16	8075975	ANTENNA
17	8074989	BEZEL, USB PORT <b>(KCCM USB)</b>
18	2207520	PLATE, BACKING USB BEZEL UHCHD
		<b>SEE WIRING DIAGRAMS IN FQG60-T SERVICE MANUAL FOR CABLE LOCATIONS</b>
*	8075555	CABLE, P-BUS W/ POWER RIGHT SIB (J9) TO VIB (VALVE INTERFACE BOARD) (J2)
*	8075550	CABLE, C-BUS RIGHT SIB (J8) TO FIB (FILTRATION INTERFACE BOARD) (J4) VATS #2 & #3
*	8075549	CABLE, C-BUS RIGHT SIB (J8) TO FIB (FILTRATION INTERFACE BOARD) (J3) VAT #1
*	8076225	CABLE, U. FL TO RP-SMA BULKHEAD (CONNECTS KCCM (SUI) TO ANTENNA 8075975 (ITEM 16))
*	8075977	CABLE, RJ45 OVERMOLD CAT5E 0.2MM (CONNECTS KCCM (SUI) RJ45 TO 8075967 (ITEM 14))
*	8074990	CABLE, USB UHCHD (CONNECTS KCCM (SUI) USB TO 8074989 (ITEM 17))
*	8075969	CABLE, USB TYPR-A RECPT PNL MNT (CONNECTS TO KCCM (SUI) USB PORT ON VATS #2 & #3)
*	8076106	ADAPTER, RJ11 CAN SIB (J8) TO LEGACY 6-PIN CAN (MICRO MATE & LOCK) (OQS SENSOR TO SIB 5")
*	8074552	TERMINATOR, CAN (ONLY USED ON OQS HARNESS Y- ADAPTOR)
*	8075632	TERMINATOR, CAN END COMMUNICATION RJ11 (USED IN SIB J7 IF OQS IS <b>NOT</b> INSTALLED)
*	8076452	HARNESS, FQ4000 SUI BOARD PWR/COM (CONNECTS TO WAGOS & SIB PIN J7 (8076106))
19	8076408	HARNESS, IGNITION MODULE SPARK TO PILOT TOUCH VAT CONTROLS (J1 SIB/J2 SIB TO C1, IGN MOD)
20	8076433	HARNESS, FQG60 FIB PWR/FLTR/BLK (CONNECTS FIB PIN J1 TO C6 (15-PIN) & CX (6-PIN))

\* Not illustrated. √ Recommended parts.

## 1.5.2 Transformer Boxes

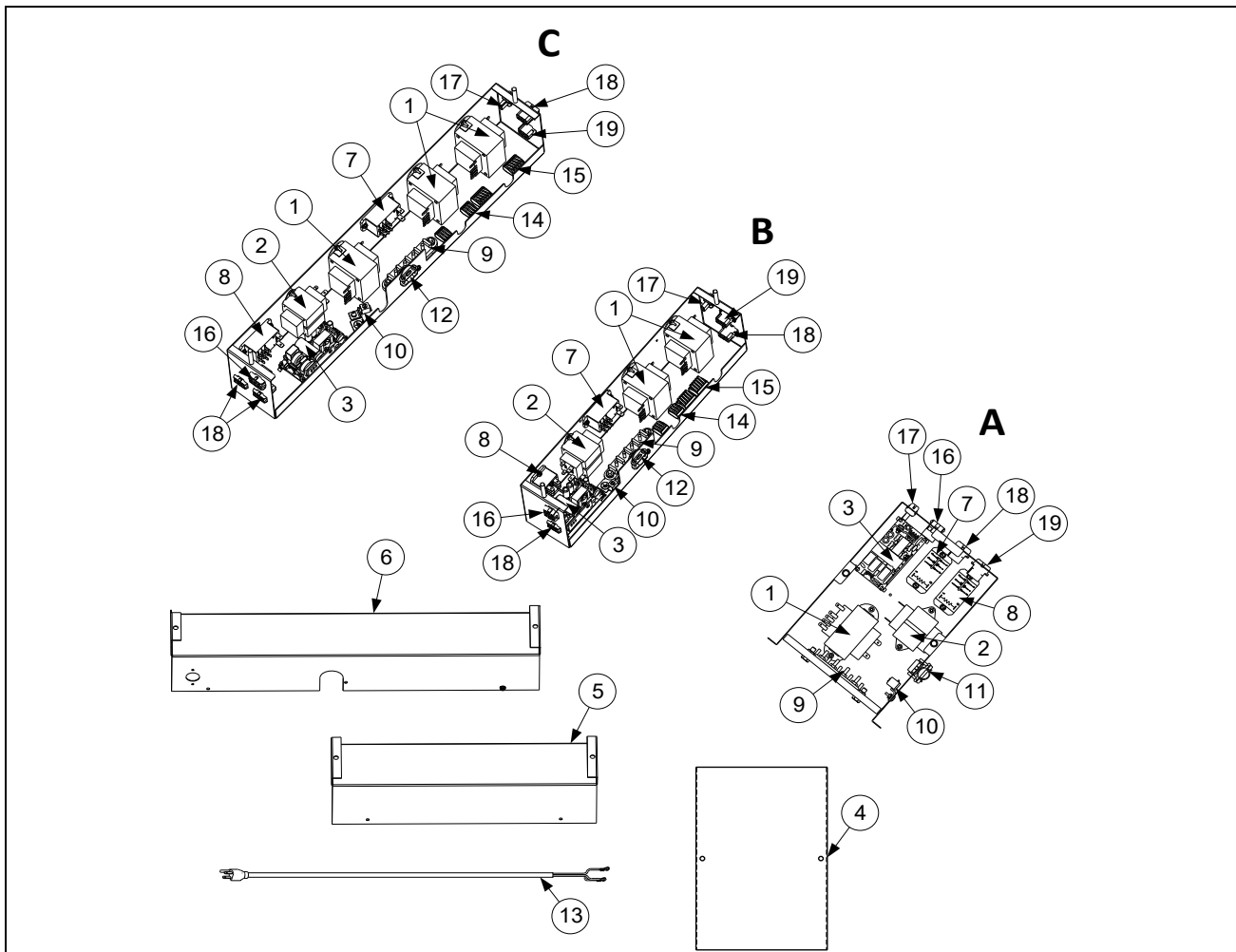

ITEM	PART #	COMPONENT
		BOX ASSEMBLY, TRANSFORMER
A	1088477	<b>1FQG60T (120V)</b>
B	1088350	<b>2FQG60T (120V)</b>
*	130248221	<b>2FQG60T (240V)</b>
C	1087558	<b>3FQG60T (120V)</b>
√ 1	8075362	TRANSFORMER, 115-240V 80VA 24VAC
√ 2	8070800	TRANSFORMER, 120V/24V 50VA <b>FILTER</b>
*	8075362	TRANSFORMER, 100V/240V 80VA <b>FILTER</b>
√ 3	8263684	POWER SUPPLY, 24VDC 130W ATO
4	2401530	LID, TRANSFORMER BOX ( <b>1FQG60T</b> )
5	2401907	COVER, TRANSFORMER BOX ( <b>2FQG60T</b> )
6	2401607	COVER, TRANSFORMER BOX ( <b>3FQG60T</b> )
√ 7	8075802	RELAY, DPDT 30A 120VAC ( <b>CONTROL POWER RESET BUTTON</b> )
*	130000358	RELAY, DPDT 30A 24V ( <b>CONTROL POWER RESET BUTTON</b> )
√ 8	8074482	RELAY, DPDT 30A 240VDC ( <b>FILTER PUMP</b> )
9	8071973	TERMINAL, POST
10	8070070	TERMINAL, GROUND LUG
11	8070141	CONNECTOR, 3/8 IN RIGHT ANGLE
12	8071612	CLAMP, 3/8 CONNECTOR TYPE (TWIN SCREW)
13	8067742	CORDSET, WITH RING TERMINALS
14	8074056	CONNECTOR, 3-WIRE SNAP

√ Recommended parts.

### 1.5.2 Transformer Boxes cont.

ITEM	PART #	COMPONENT
15	8074154	CONNECTOR, 5-WIRE SNAP
16	1087726	HARNESS, FILTER MOTOR
17	1088229	HARNESS, RESET RELAY
18	1088451	HARNESS, TRANSFORMER VAT #2
19	8076467	HARNESS, HD GAS FIB PWR/PUMP CONTROL
*	8076241	HARNESS, POWER SUPPLY
*	WIR1246	WIRE ASSY, TRANSFORMER <b>1FQG60T</b> (USED IN ITEM A)
*	WIR1242	WIRE ASSY, TRANSFORMER <b>2FQG60T</b> (USED IN ITEM B)
*	WIR1243	WIRE ASSY, TRANSFORMER <b>3FQG60T</b> (USED IN ITEM C)

\* Not illustrated

### 1.5.3 VIB (Valve Interface Board) Components

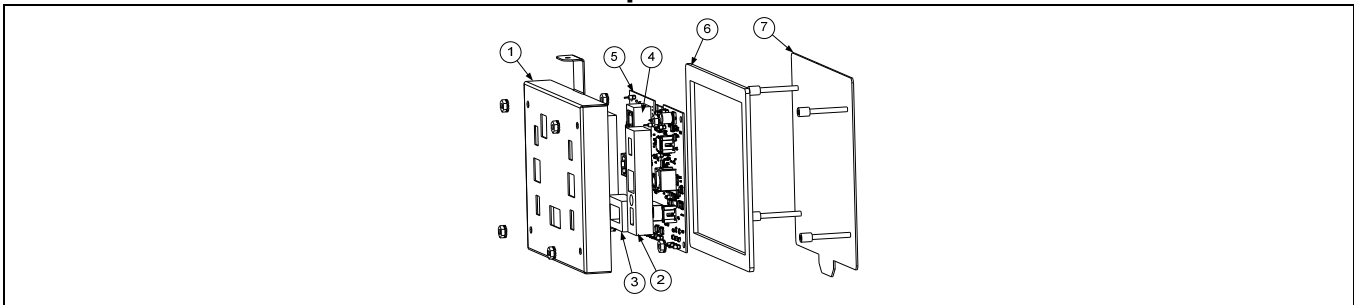

ITEM	PART #	COMPONENT
√	1087514SP	VIB BOARD ASSEMBLY
1	8242346	COVER, VIB BOARD HOUSING
2	8161015	GASKET, ACTUATOR POWER VIB
3	8161013	GASKET, 20 PIN VIB CONNECTOR
4	8161014	GASKET, P-BUS VIB CONNECTOR
5	1087512SP	BOARD, VIB WITH SW
6	8160820	SEAL, LINEAR ACTUATOR BOARD
7	1087280	PANEL, ASSY VIB BOX BOTTOM STUD
*	8076440	HARNESS, FQG60 FLTR/ATO PWR/CNT (FROM CONTROL BOX (CX) TO VIB BOARD (J4))
*	8075810	CABLE, VIB ACTUATOR POWER (USED FROM VIB (J3) TO VIB (J4))

√ Recommended parts. \* Not illustrated

### 1.5.4 Power Reset Switch and USB Connector

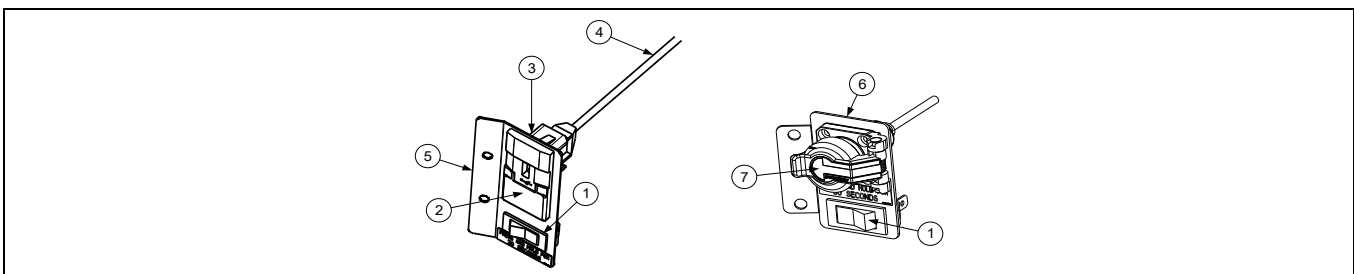

ITEM	PART #	COMPONENT
	1087802	BRACKET ASSY, USB MOUNTING FQ4000 GAS
1	8072659	SWITCH, MOMENTARY ( <b>POWER RESET</b> ) (USED WITH RESET HARNESS 1088233)
2	8074989	BEZEL, USB PORT
3	2207520	PLATE, BACKING USB BEZEL
4	8074990	CABLE, USB
5	2602065	BRACKET, FQ4000 GAS USB/RESET
	130000192	BRACKET ASSY, USB MOUNTING GAS
6	2602358	BRACKET, USB/RESET
7	8105041	USB, SELF-CLOSING FLANGE

## 1.6 Wiring

### 1.6.1 Wiring Harness SIB to Rear of Component Box (Spark to Pilot)

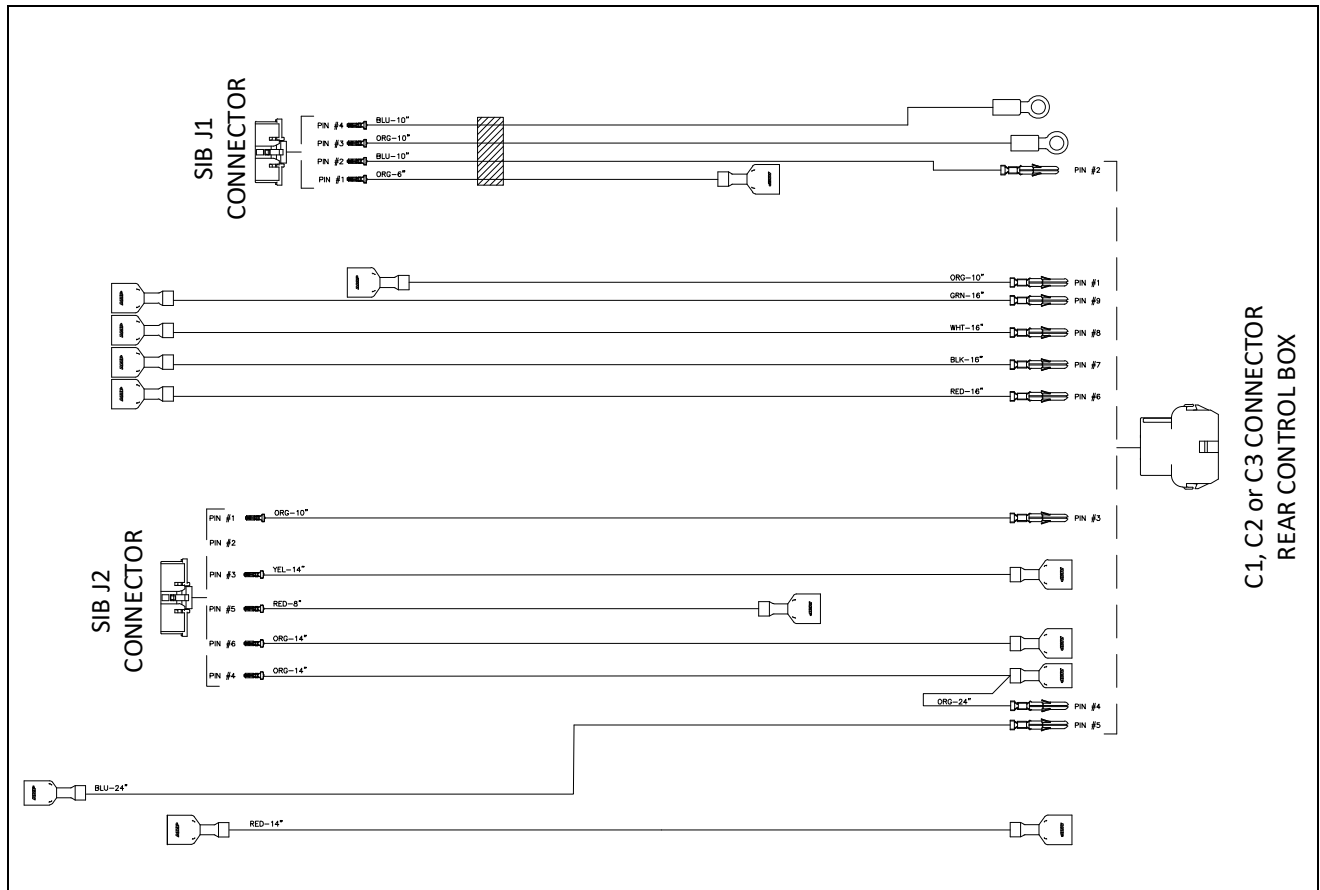

ITEM	PART #	COMPONENT
	8076408	HARNESS, SPARK TO PILOT TOUCH VAT CONTROLS

See the FQG60-T wiring diagram on last page.

### 1.6.2 Wiring Harness FIB, Power, Filter, ATO, Bulk

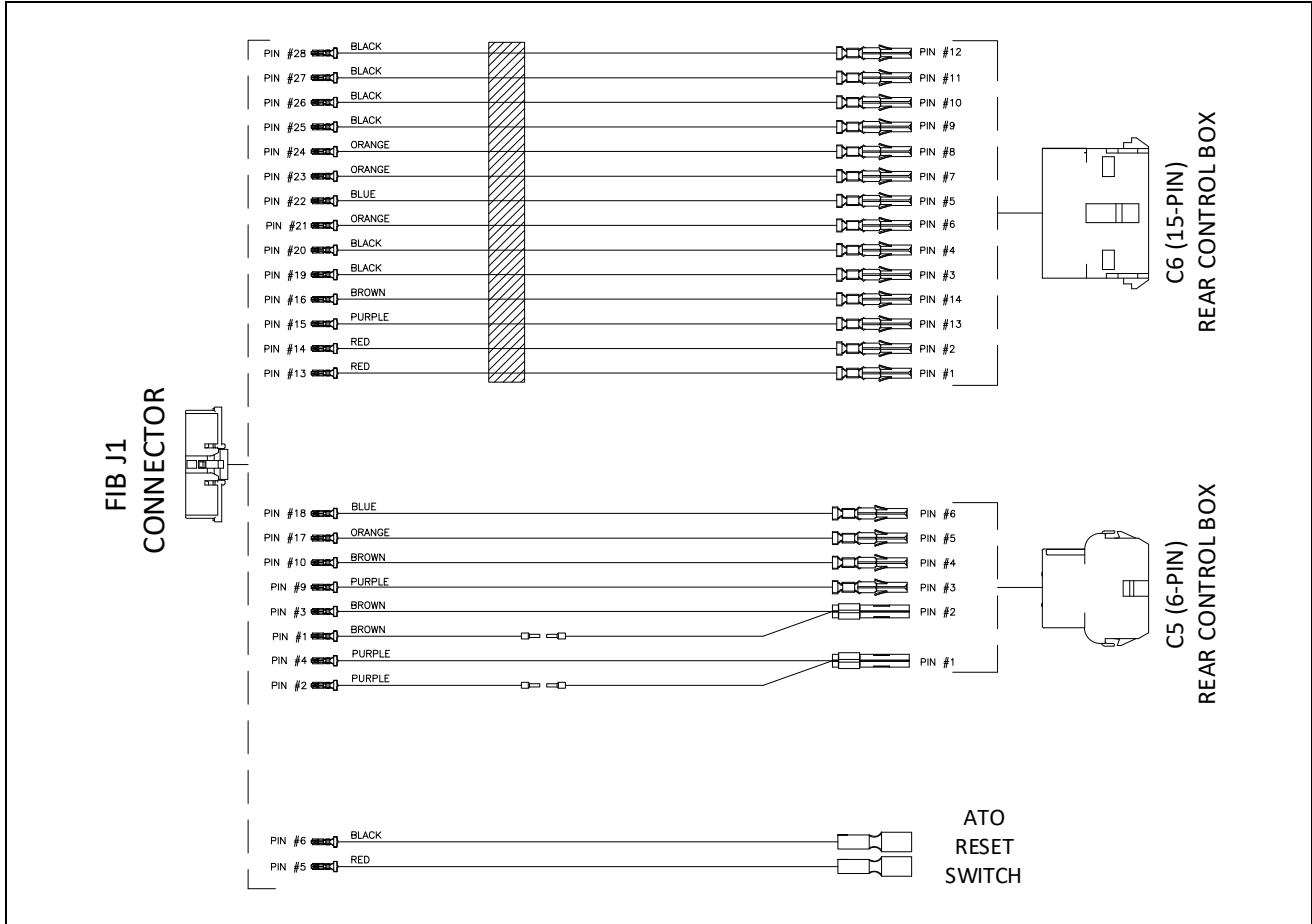

ITEM	PART #	COMPONENT
	8076433	HARNES, FIB, POWER, FILTER, BULK

See the FQG60-T wiring diagram on page 35.

### 1.6.3 Wiring Harness Filter, ATO, Power, CTL

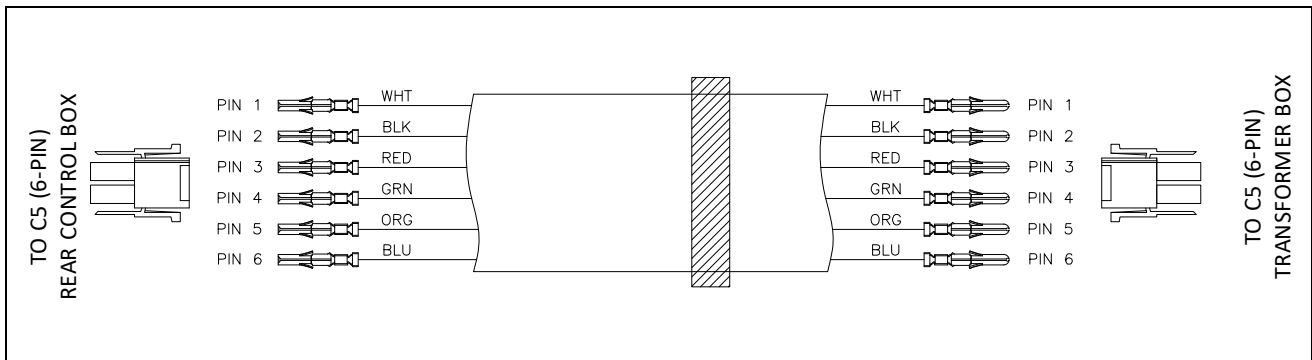

ITEM	PART #	COMPONENT
	8076440	HARNES, FILTER, ATO, POWER, CTL FQG60

See the FQG60-T wiring diagram on last page.

### 1.6.4 Wiring Harness Power, Float, VIB, Gas

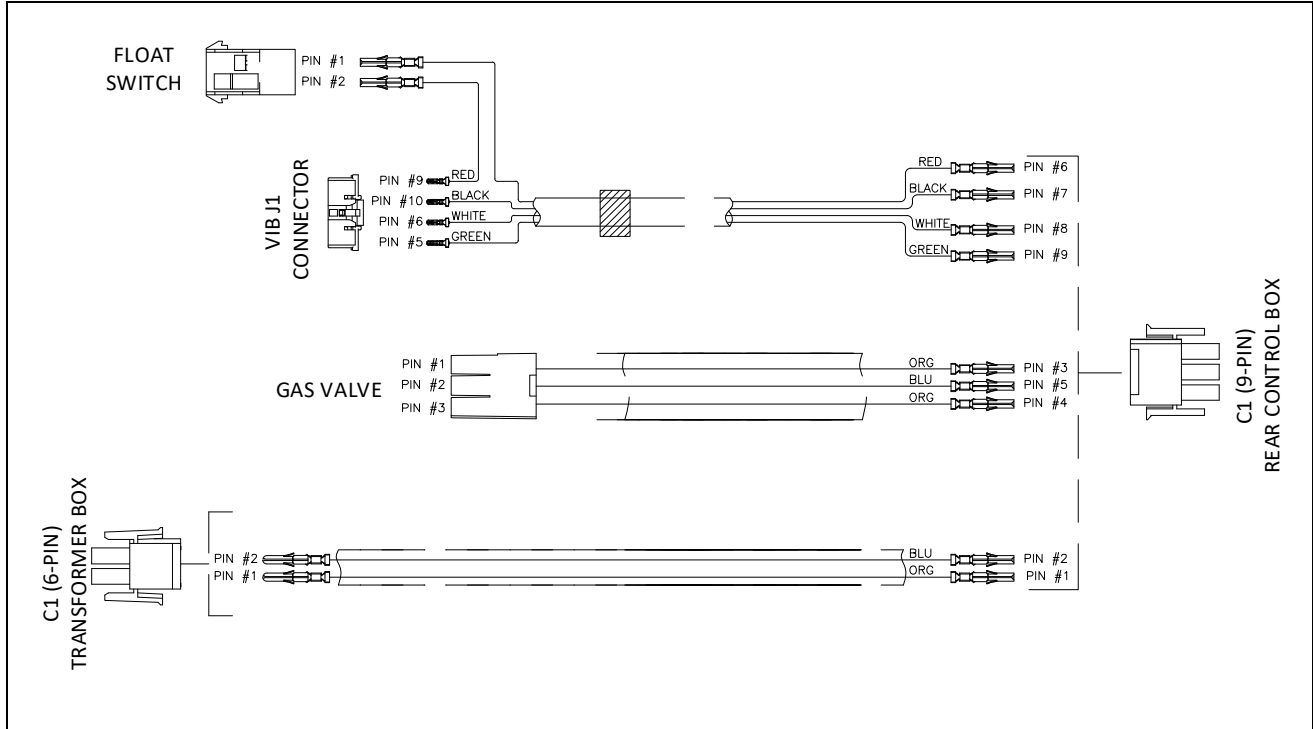

ITEM	PART #	COMPONENT
	8076434	HARNESS, VAT POWER, FLOAT, VIB, GAS

See the FQG60-T wiring diagram on last page.

### 1.6.5 Wiring Harness Dispose, Pan Switch

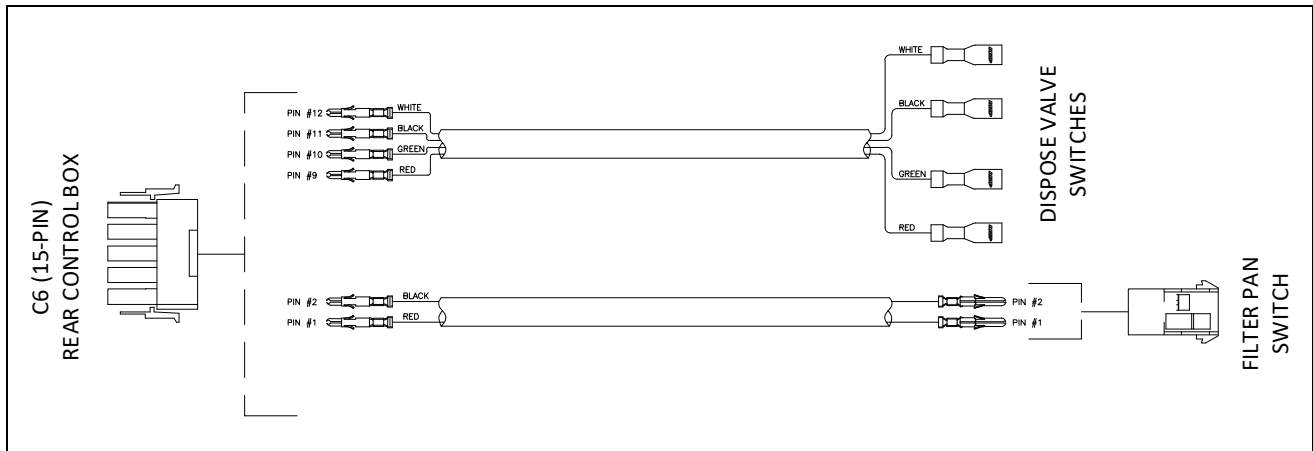

ITEM	PART #	COMPONENT
	8076443	HARNESS, DISPOSE/PAN SWITCH

See the FQG60-T wiring diagram on last page.

### 1.6.5.1 Wiring Harness Dispose, Pan Switch

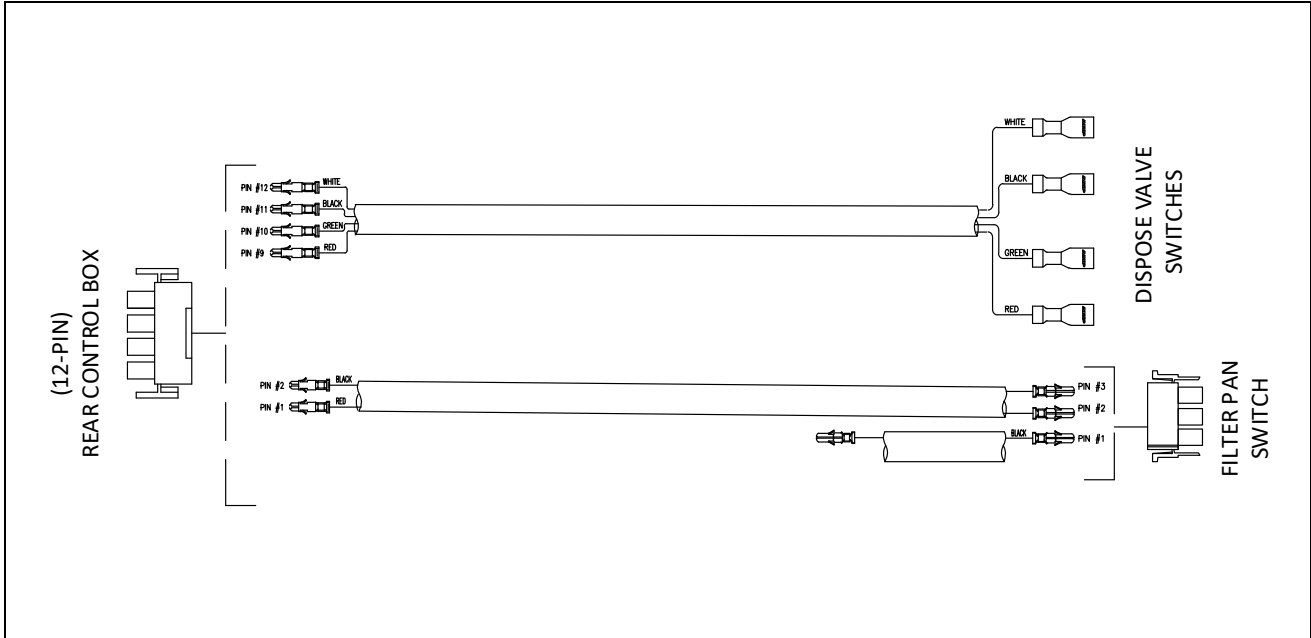

ITEM	PART #	COMPONENT
	8076675	HARNESS, FQ DISPOSE/PAN SWITCH

### 1.6.5.2 Wiring Harness, Pan Switch

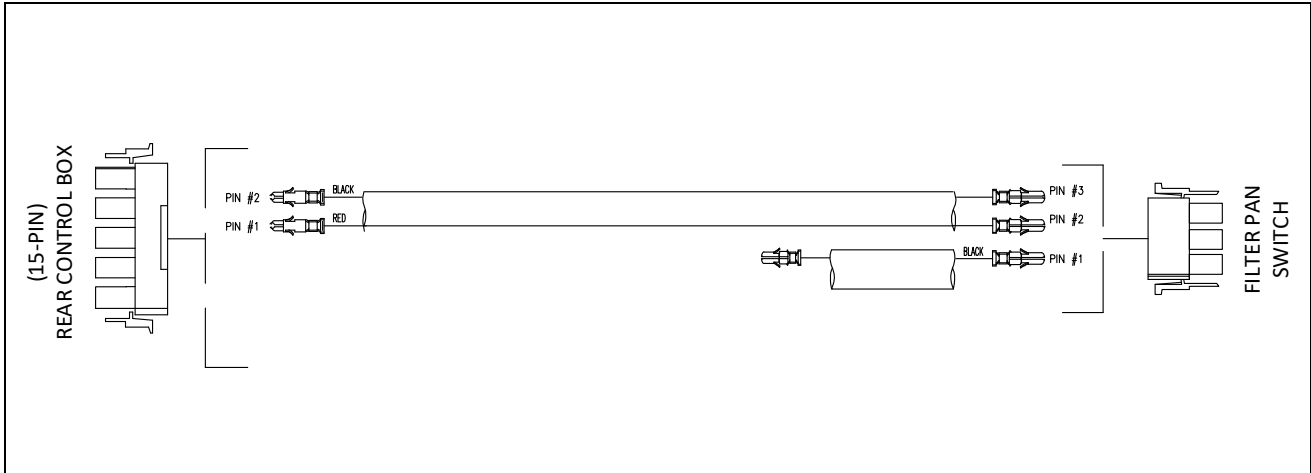

ITEM	PART #	COMPONENT
	8076674	HARNESS, FQ60 PAN SWITCH

## 1.6.6 Wiring Harness Dispose, Pan Switch, Bulk

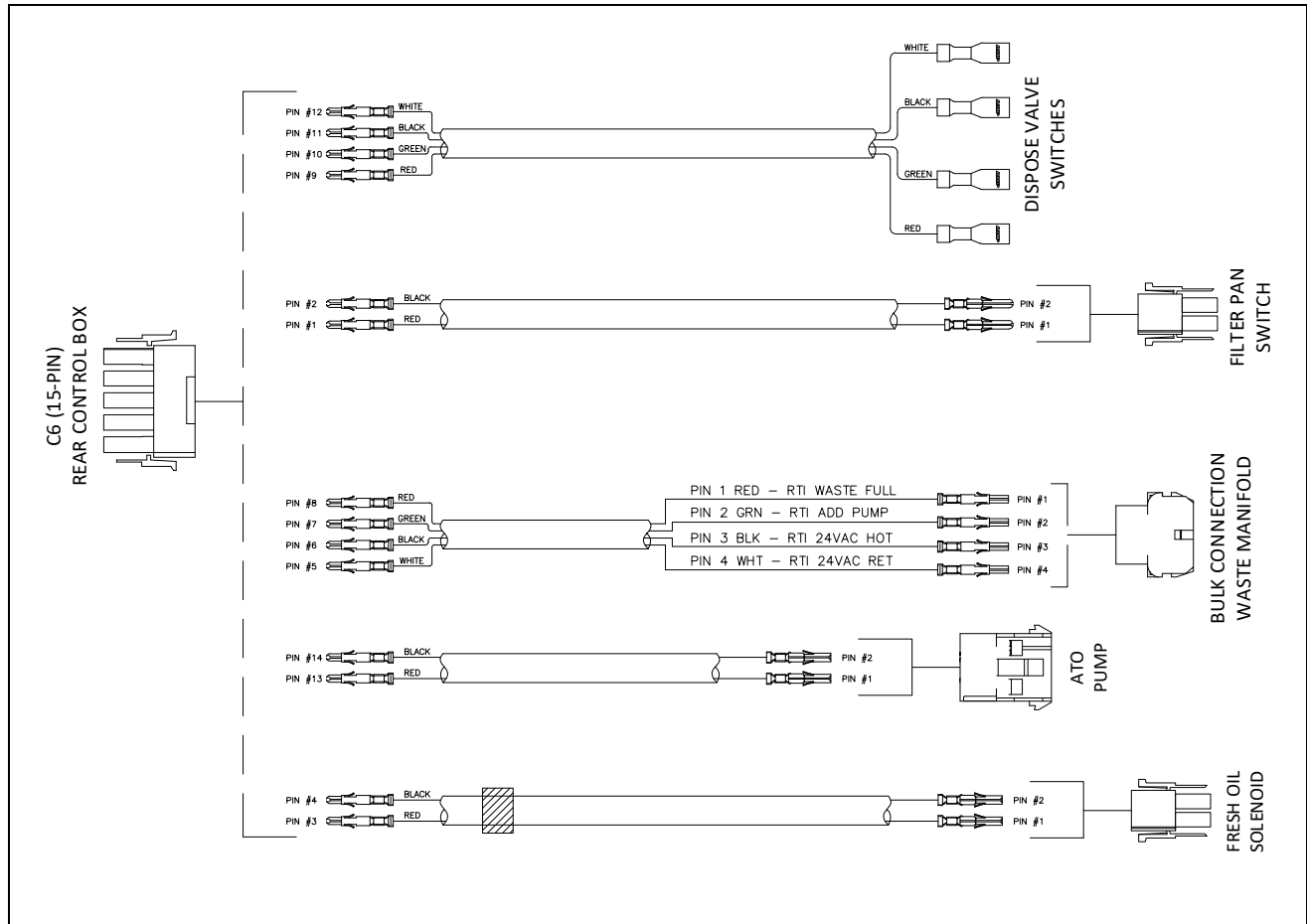

ITEM	PART #	COMPONENT
	8076439	HARNES, DISPOSE/PAN SWITCH/ BULK

See the FQG60-T wiring diagram on page 35.

## 1.6.7 Miscellaneous Wiring Harnesses and Cord Sets

PART #	COMPONENT
8076246	HARNES, BASKETLIFT 72" (12-PIN BASKETLIFT)
8069678SP	PLUG ASSEMBLY, CE GAS VALVE
8067742SP	CORD SET, 120V FRYER AND MOTOR WITH RING TERMINALS 68"
1060516	CORD SET, 220-250V NON-CE/EXPORT FRYER AND MOTOR WITH RING TERMINALS 68"

See the FQG60-T wiring diagram on last page.



## 1.7 Frypots and Associated Components

### 1.7.1 Frypot Components

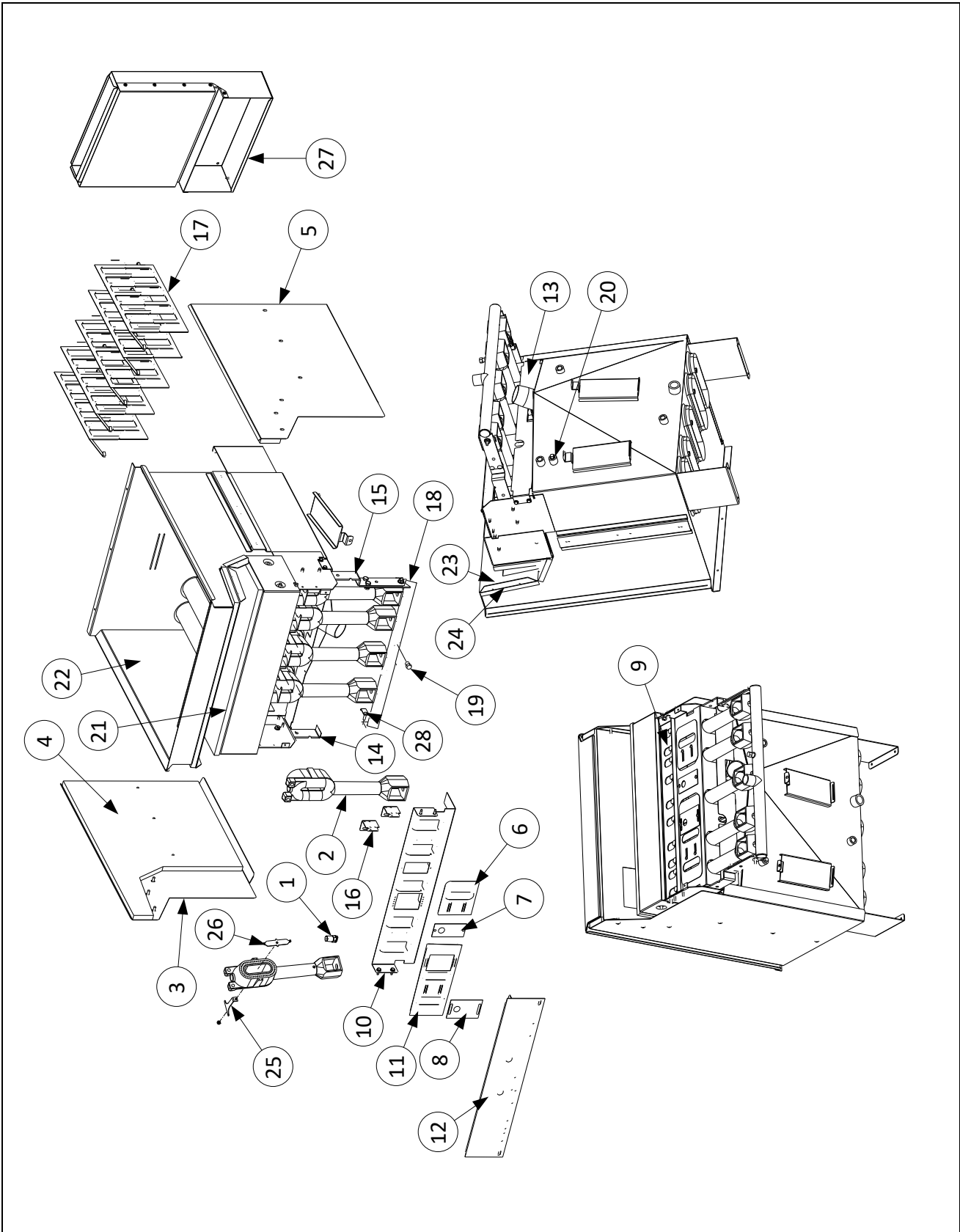

## 1.7.1 Frypot Components cont.

ITEM	PART #	COMPONENT
	1087162SP	FRYPOT, W INSULATION (1FQG60T)
	1087446SP	FRYPOT, WITH INSULATION (2FQG60T, 3FQG60T)
1		<b>NATURAL GAS ORIFICES</b>
	8102938	0-1999 FT. 2.26MM
	8103053	2000-3999 FT. 2.18MM
	8103054	4000-5999 FT. 2.10MM
	8103055	6000-7999 FT. 2.04MM
	8103056	8000-8999 FT. 1.98MM
	8103057	9000-10000 FT. 1.94MM
	8102060	2.40 MM CE
	8103801	2.35 MM (CHINA)
	8103132	2.20 MM
		<b>PROPANE (LPG) GAS ORIFICES</b>
	8102939	0-1999 FT. 1.40MM
	8102940	0-1999 FT. 1.32MM (LP-BUTANE MIX)
	8103058	2000-3999 FT. 1.35MM
	8103059	4000-5999 FT. 1.30MM
	8103060	6000-7999 FT. 1.26MM
	8103061	8000-8999 FT. 1.22MM
	8103062	9000-10000 FT. 1.20MM
	8102059	1.51 MM (100% BUTANE INDIA)
2	8103356	BURNER, CAST UNIVERSAL
3	2219951	SIDE, HD50 INSULATION BRACKET LH
4	8160915	INSULATION, HD50 FRYPOT SIDE TOP (USED WITH ITEM #3 AND #4)
5	2229951	SIDE, HD50 INSULATION BRACKET RH
6	2208734	SHUTTER, HD50 BURNER
7	2208858	DOOR, HD50 IGNITOR
8	2208865	DOOR, HD60 IGNITOR ACCESS
9	2209905	BRACKET, HD60 BURNER MOUNTING
10	2209906	BOX, HD60 BURNER AIR
11	2209908	SHUTTER, HD60 LONG BURNER
12	2209948	SHIELD, HD60 LOWER HEAT
13	2209967	SHIELD, HD60 LOWER AIR
14	2219912	BRACKET, HD60 MANIFOLD SPPT LH
15	2229912	BRACKET, HD60 MANIFOLD SPPT RH
16	2306887	BAFFLE, HE50 8 ROW BURNER
17	2306301	BRACKET, HD PILOT BURNER
18	8104691	MANIFOLD, FYPOT GAS (1FQG60T)
	8102072	MANIFOLD ASSY GAS (2FQG60T, 3FQG60T)
19	8130154	PLUG, PIPE 1/8NPT HX HD
20	8130640	PLUG, BLK,1/4, SQ HD
21	8160921	INSULATION, HD60 FRYPOT BOX
22	8239248	FRYPOT
23	2411509	BRACKET, FRYPOT UPPER INSUL FQ1814G
24	8160922	INSULATION, FRYPOT FRONT
25	2308947	BRACKET, HD BURNER AIR FLOW MTG
26	1083781	BRACKET STUD ASSY, HD BURNER AFD
27	1080983	FLUE ASSY, TALL
28	1069622	BRACKET ASSY, MANIFOLD SUPPORT

\* Not illustrated.

√ Recommended parts.

## 1.7.2 Frypot Assemblies and Associated Parts

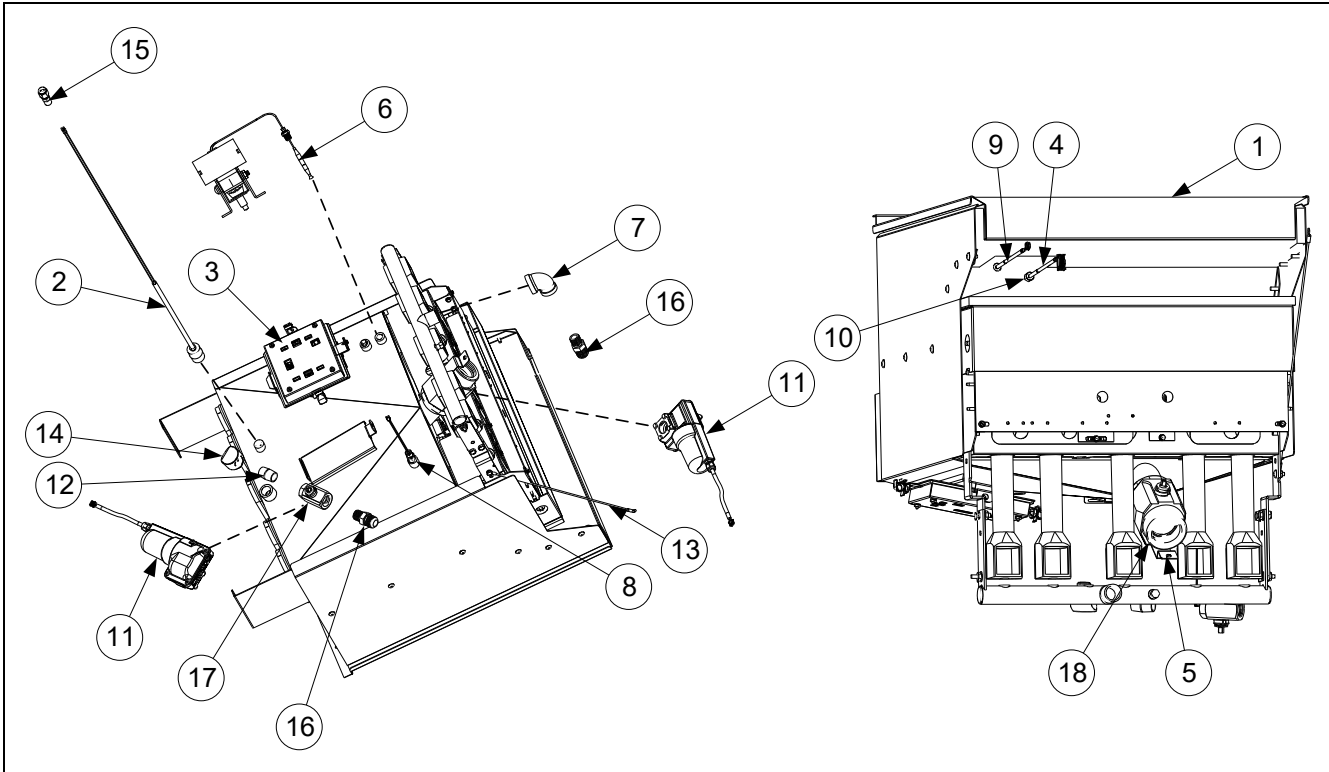

ITEM	PART #	COMPONENT
1	1087162SP	FRYPOT ASSEMBLY (1FQG60T)
	1087446SP	FRYPOT ASSEMBLY (2FQG60T, 3FQG60T)
✓ 2	8263643	SWITCH ASSY, FLOAT
✓ 3	1087514SP	VIB BOARD ASSEMBLY
✓ 4	8263287	PROBE, VIB (AUTO FILTRATION) RTD KIT
*	8075953	CONNECTOR, MOLEX 20 PIN (USED WITH ITEM #4)
5	2401511	STRAP, DRAIN FQ1814G (1FQG60T)
	2401577	STRAP FQ1814 DRAIN RETAINING (2FQG60T, 3FQG60T)
✓ 6	8073680	HI-LIMIT, 450F W/MANUAL RESET
7	8130068	ELBOW, REDUCING 3/4 X 1/2 (1FQG60T)
✓ 8	8263642	PROBE, TEMPERATURE KIT
*	8075674	CONNECTOR, MOLEX 2MM 2-PIN (USED WITH ITEM #8)
*	8160536	SLEEVING, PVC COATED FIBERGLASS (.208" DIA.) (USED WITH ITEM #8)
✓ 9	8263286	PROBE, ATO (TOPOFF) RTD KIT
10	8130617	FITTING, 3/16" CC X 1/4" (COMPRESSION FITTING USED IN PROBE KITS #4, #8 & #9)
✓ 11	8075809	ACTUATOR, ROTARY 24VDC (#1) BLUE
12	8130022	NIPPLE, 1/2" X CLOSE NPT
13	W88C510	WIRE 88C 03 15.0 34 34 (TO GROUND STUD IN FRONT BOX)
14	8130908	ADAPTER, 1/2" NPT 90°
15	8130619	COMPRESSION FTNG, 1/4NPTX5/16D (USED WITH ITEM #2)
16	8101668	ADAPTOR, MALE 5/8" OD X 1/2"
✓ 17	8103754	VALVE, 1/2" NPT RETURN
✓ 18	8263817	VALVE, 1 1/2" NPT DRAIN KIT (INCLUDES 8160544 O-RING)
*	8160544	O-RING SEAL - DRAIN
*	8158000	LOCTITE 567, TUBE 6 ML

\* Not illustrated. ✓ Recommended parts.

## 1.8 Oil Return Manifolds

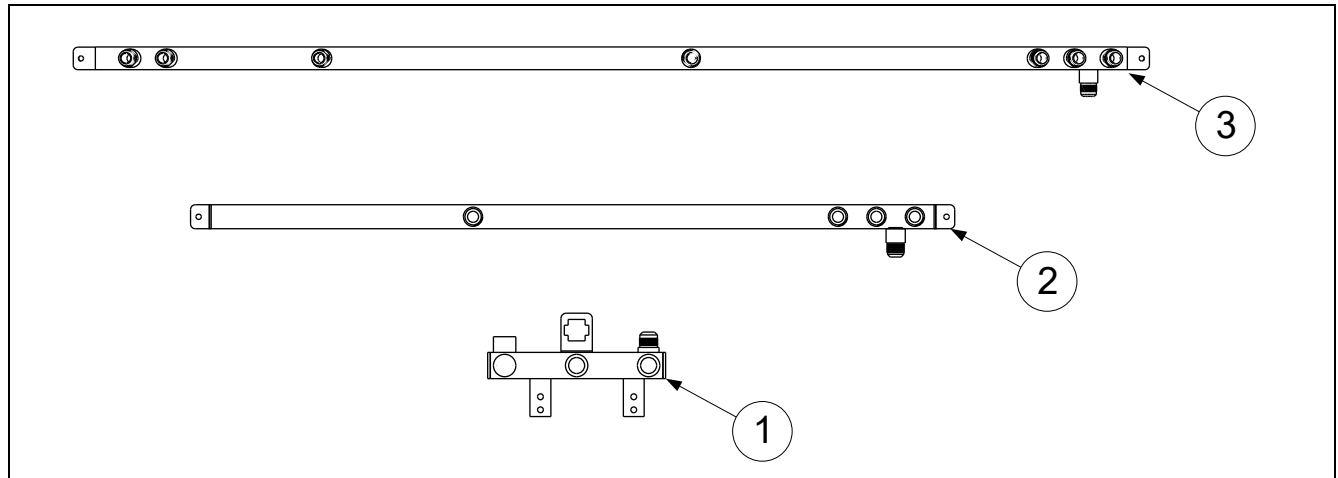

ITEM	PART #	COMPONENT
1	8104882	MANIFOLD (1FQG60T)
2	8104788	MANIFOLD (2FQG60T)
3	8104811	MANIFOLD (3FQG60T)
*	8130907	CAP, 15/16" VALVE

\* Not illustrated

## 1.9 Gas Supply and Combustion System Components

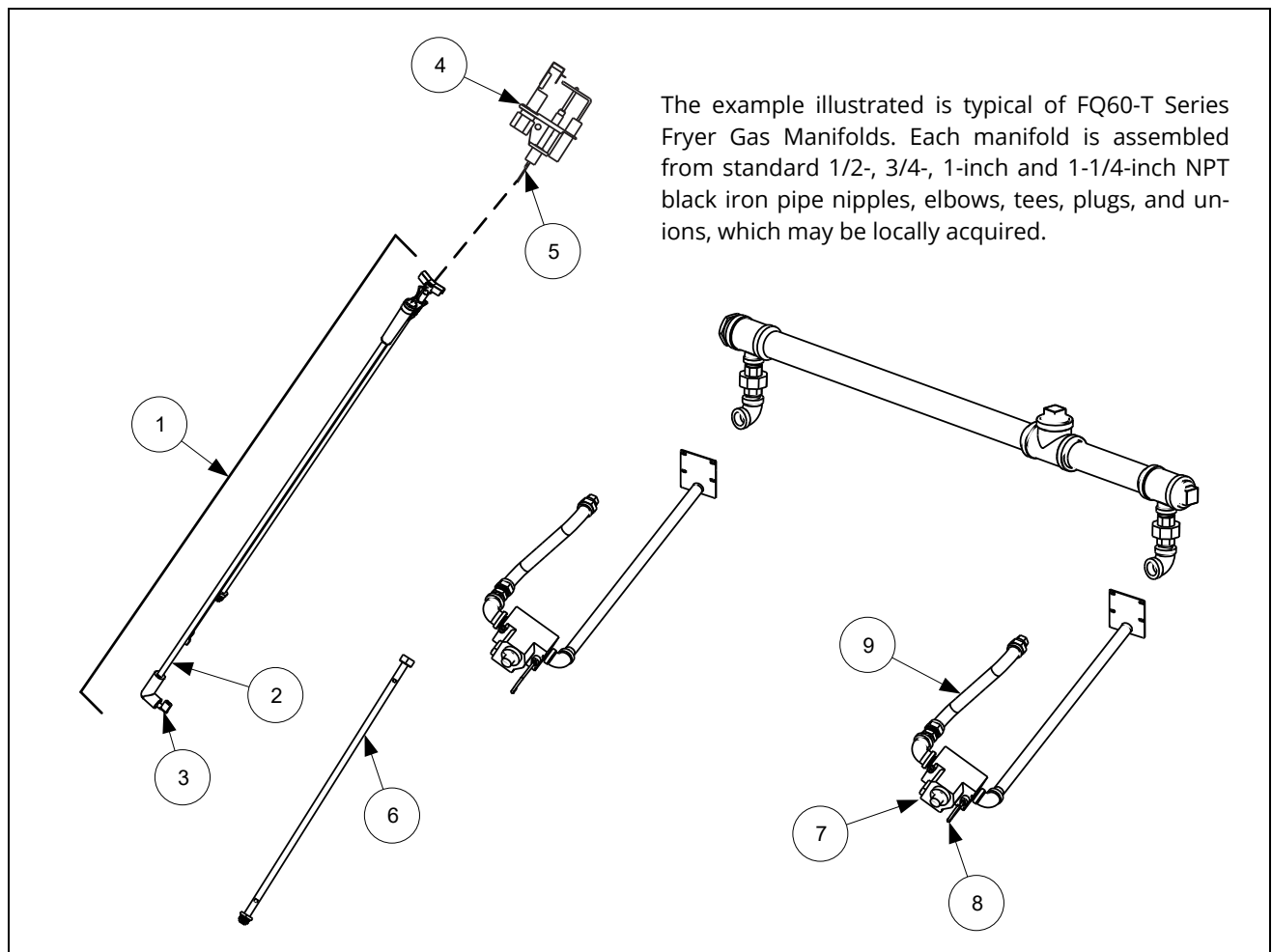

## 1.9 Gas Supply and Combustion System Components cont.

ITEM	PART #	COMPONENT
√ 1		<b>PILOT ASSEMBLIES</b>
	1061839SP	<b>NATURAL</b> GAS (G20, G25) ELEC. IGN. W/ IGN. CABLE NON-CE ( <i>FRYERS W/ 8075991 MODULE</i> )
	130000441	<b>NATURAL</b> GAS (G20, G25) ELEC. IGN. ( <i>FRYERS W/130197410 LOCAL SENSE MODULE</i> )
	1061128SP	<b>PROPANE</b> (LP) (G30, G31) ELEC. IGN. W/ IGN. CABLE NON-CE ( <i>FRYERS W/ 8075991 MODULE</i> )
	130000442	<b>PROPANE</b> (LP) (G30, G31) ELEC. IGN. ( <i>FRYERS W/130197410 LOCAL SENSE MODULE</i> )
2	1067535SP	CABLE ASSY, IGNITION DEAN
3	8074375	CONNECTOR, 90 RAJAH
	8074384	CABLE, IGNITION DEAN
4	1081650SP	PILOT ASSY, <b>NAT</b> FP-TCF IGN (INCLUDES FLAME SENSOR)
	1081651SP	PILOT ASSY, <b>LP</b> FP-TCF IGN (INCLUDES FLAME SENSOR)
√ 5	8071310	FLAME SENSOR
*	W68C11	FLAME SENSE WIRE, 68C 39 26.0 67 69
6	8100705	TUBE, PILOT GASLINE ONE-PIECE ¼" X 23"
	8100703	TUBE, PILOT GASLINE ONE-PIECE ¼" X 20"
√ 7		<b>VALVE, NON-CE GAS</b>
	8073552	NATURAL GAS (G20, G25) HONEYWELL
	8073628	PROPANE GAS (LP) (G30, G31)
		<b>GAS CONVERSION KITS</b>
	8262937	CONVERSION KIT, VALVE, NATURAL (G20, G25) TO PROPANE (LP) (G30, G31)
	8262938	CONVERSION KIT, VALVE, PROPANE (LP) (G30, G31) TO NATURAL (G20, G25)
8	8100691	TUBE, ⅛" VENT
√ 9		<b>FLEXLINES</b>
	8101055	FLEXLINE, ⅝" OD X 11.50"
	8102542	FLEXLINE, ¾" OD X 18.50"

\* Not illustrated.

√ Recommended parts.

## 1.10 Filtration System Components

### 1.10.1 Filter Pan and Accessories

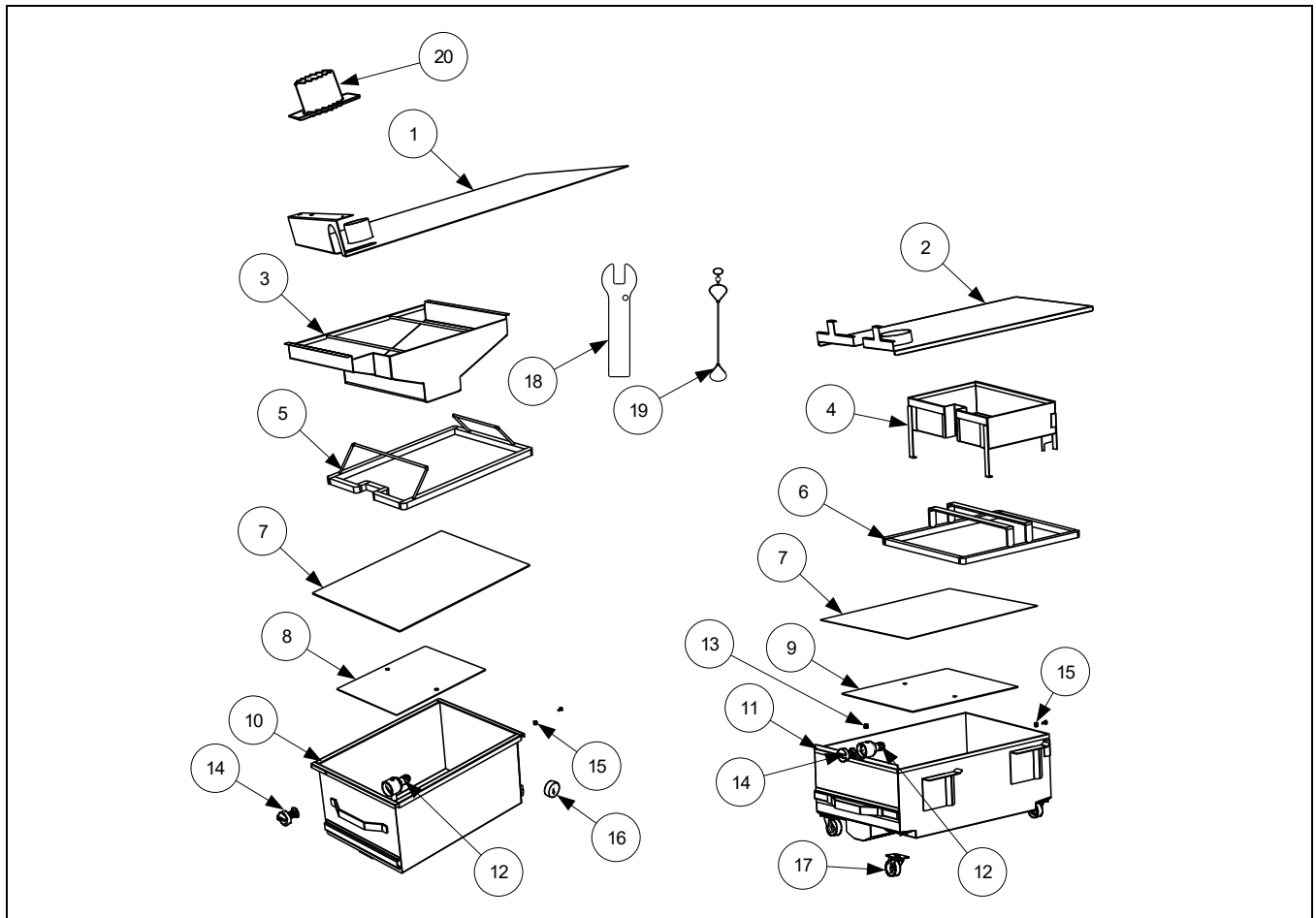

ITEM	PART #	COMPONENT
1	8239253	LID, FILTER PAN (1FQG60T)
2	8239339	LID, FILTER PAN (2FQG60T, 3FQG60T)
3	130001292	CRUMB TRAY (1FQG60T)
4	8237425	CRUMB TRAY (2FQG60T, 3FQG60T)
5	8103414	HOLD-DOWN RING 13.85" X 20.80" (1FQG60T)
6	8103541	HOLD-DOWN RING 15.75" X 19.02" (2FQG60T, 3FQG60T)
7	8030289	PACK, 100-SHEET FILTER PAPER 22" X 34"
8	2204446	SANA GRID FILTER SCREEN(1FQG60T)
9	8122296	SANA GRID FILTER SCREEN (2FQG60T, 3FQG60T)
10	1087409SP	PAN, FILTER ASSEMBLY WITH CASTERS (1FQG60T)
11	1088924SP	PAN, FILTER ASSEMBLY WITH CASTERS (2FQG60T, 3FQG60T)
√ 12	8263288	O-RING (PKG. OF 6; USED WITH ITEMS 10 & 11)
13	8130568	PLUG, 1/8" SOCKET HEAD PIPE (USED WITH ITEMS 10 & 11)
14	8238335	SCREEN, SUCTION LINE FILTER (USED WITH ITEMS 10 & 11)
15	8103007	MAGNET, PULL RING (USED WITH ITEMS 10 & 11)
16	8104941	WHEEL, 2" (USED WITH ITEM 10) (1FQG60T)
17	8102805	CASTER, 2" (USED WITH ITEM 11) (2FQG60T, 3FQG60T)
18	2401086	WRENCH, PRE-FILTER CAP
19	8104167	LANYARD, FILTER SCREEN WRENCH
20	8236713	GUARD, SPLASH

\* Not illustrated.

√ Recommended parts

### 1.10.1.1 FQG60 MasterFil Filter Pan and Accessories

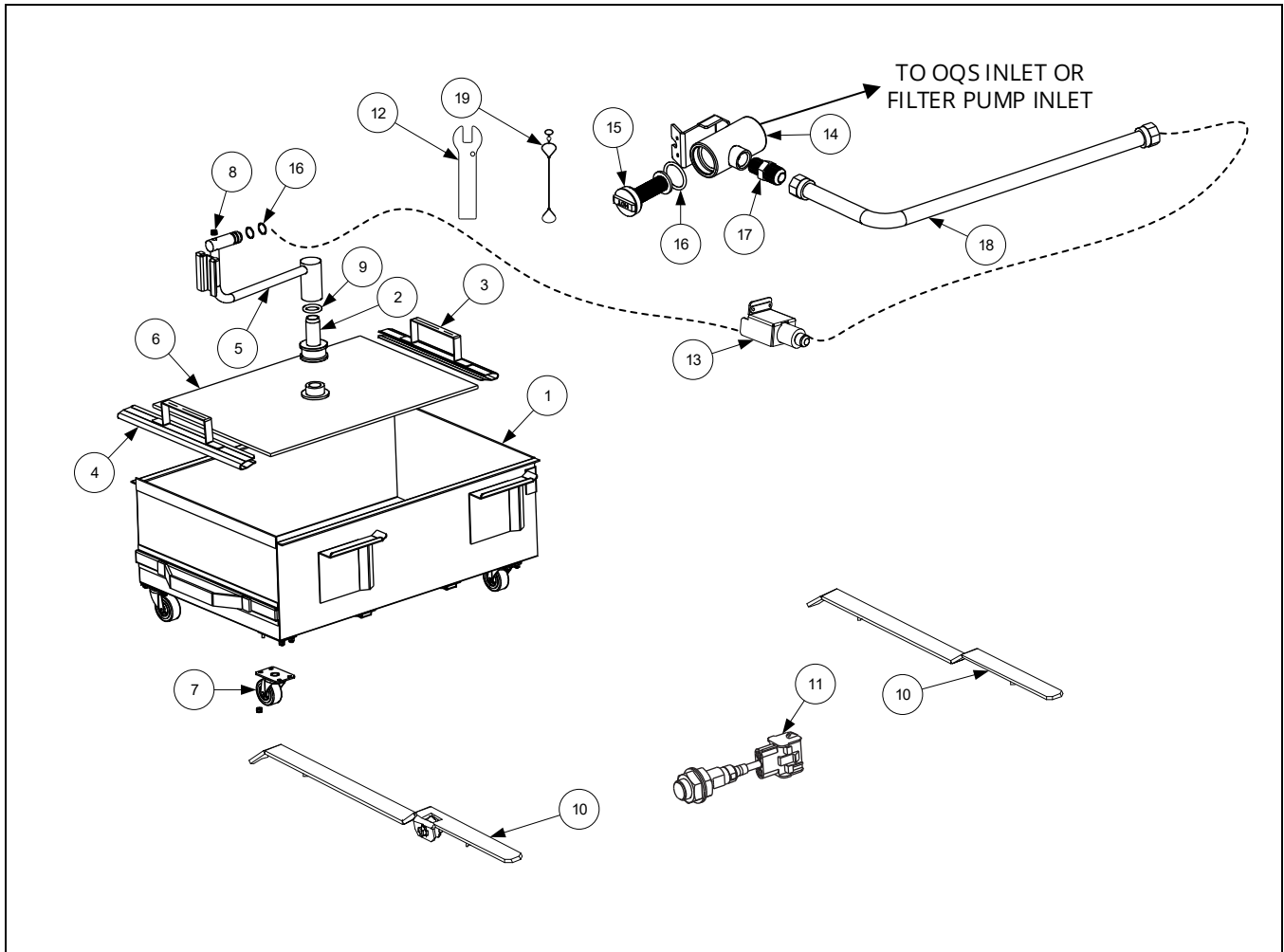

ITEM	PART #	COMPONENT
	130000763	PAN ASSY, FILTER FQG60
1	130000762	PAN W/A, FILTER FQG60
2	130001215	ADAPTER, MASTERFIL SCREEN W/GROOVE
3	130001465	CLIP W/A, MASTERFIL SCREEN 12" SECONDARY
4	130001467	CLIP W/A, MASTERFIL SCREEN 14" PRIMARY
5	130001472	TUBE ASSY, SUCTION FQG60 MASTERFIL
6	130168513	SCREEN, OIL SOLUTIONS GROUP W/HANDLES 13.50 X 19.50
7	8102805	CASTER, 2"
8	8130989	PLUG, 1/8" NPT SOCKET-HEAD .250
9	130000779	O-RING, .210X.975X1.395
10	8233347	SLIDE W/A, FILTER PAN
√ 11	8263857	SENSOR ASS`Y, PAN FQ60 ( <b>PROXIMITY SENSOR</b> )
12	2401086	WRENCH, PRE-FILTER CAP
13	130001223	BRACKET W/A, FILTER SUCTION FQ60
14	130001230	BODY W/A, PRE-FILTER FQ60 LONG
√ 15	8239651	SCREEN, SUCTION LINE ( <i>USED WITH ITEM 5</i> )
√ 16	8263666	KIT, O-RING FQ120 PAN/PRE-FLTR ( <b>INCLUDES 12-8160596[PAN], &amp; 6-8161213[PRE-FLTR]</b> )
17	8101668	ADAPTOR, MALE 5/8" O.D. X 1/2"
18	8101068	FLEXLINE, 5/8" OD X 21.50 LONG
19	8104167	LANYARD, FILTER SCREEN WRENCH
*	SEE DESCRIPTION	FILTER ENVELOPES ( <b>FE1522X</b> ) <b>CONTACT <a href="http://WWW.OILSOLUTIONSGROUP.COM">WWW.OILSOLUTIONSGROUP.COM</a> OR CALL 888-459-2112</b>

\* Not illustrated.

√ Recommended parts

## 1.10.2 Filter Pump and Accessories (1FQG60T)

Pump plumbing may differ somewhat from illustration depending on configuration and date of manufacture.

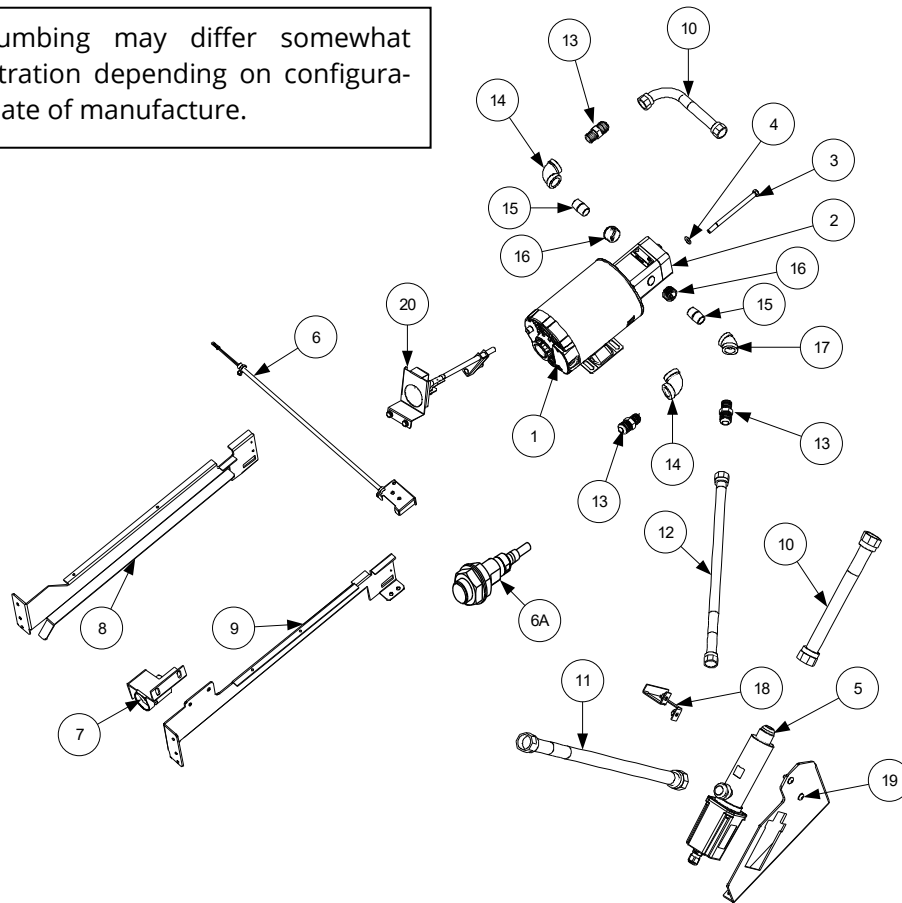

ITEM	PART #	COMPONENT
√ 1		MOTOR AND GASKET KIT
	8261785	100V 50/60 HZ
	8261712	115V 50/60 HZ
	8261756	208V 50/60 HZ
	8261270	220-240V 50/60 HZ
	8261755	250V 50/60 HZ
*	1088658	WIRES, FQG60 PUMP MOTOR POWER
√ 2	8263192	PUMP & GASKET KIT, 8 GPM <b>(INCLUDES 8160093, 8091020 &amp; 8090194)</b>
	8263415	PUMP & GASKET KIT, 8 GPM <b>W/ HEATER HOLE (INCLUDES 8160093, 8091020 &amp; 8090194)</b>
	8160093	GASKET, PUMP/MOTOR
3	8091020	CAP SCREW, 5/16-INCH-18 5.00" NC HEX <b>(CONNECTS PUMP TO MOTOR) (USE 8090194 WASHERS)</b>
4	8090194	WASHERS
*	8071105	HEATER STRIP ASSEMBLY, 100-120V 25W 18"
*	8071098	HEATER STRIP ASSEMBLY, 208-250V 25W 18"
5	8263292	SENSOR, FILTERQUICK OQS REPLACEMENT
6	1087010SP	SENSOR ASSY, MAGNETIC POSITION <b>(1FQG60T)</b>
6A	8263849	SENSOR, PROXIMITY
7	8239201	BRACKET, FILTER SUCTION <b>(1FQG60T)</b>
8	2401503	SUPPORT, FILTER PAN LEFT <b>(FILTER PAN RAIL)</b>

\* Not illustrated.

√ Recommended parts



### 1.10.2 Filter Pump and Accessories (1FQG60T) cont.

ITEM	PART #	COMPONENT
9	2401504	SUPPORT, FILTER PAN RIGHT ( <i>FILTER PAN RAIL</i> )
10	8101067	FLEXLINE, 5/8" OD X 8.50"
11	8101057	FLEXLINE, 5/8" OD X 13"
12	8101369	FLEXLINE, 5/8" OD X 17.50"
13	8101668	ADAPTER, 5/8" TO 1/2" NPT MALE
14	8130062	ELBOW, 1/2" 90° BM
15	8130022	NIPPLE, 1/2 X CLOSE N.P.T. B.M.
16	8130763	BUSHING, 3/4OD X 1/2ID NPT FLUSH
17	8130345	ELBOW, 1/2" 45° BM
18	2401385	RETAINER, OQS SENSOR FQ
19	2401456	MOUNT, OQS
20	1087104	RESET, FILTER PUMP MOTOR ( <b>1FQG60T</b> )
*	2602494	BRACKET, PUMP RESET ( <i>USED WITH ITEM 20</i> )

\* Not illustrated. ✓ Recommended parts.

### 1.10.3 Filter Pump and Accessories (2FQG60T, 3FQG60T)

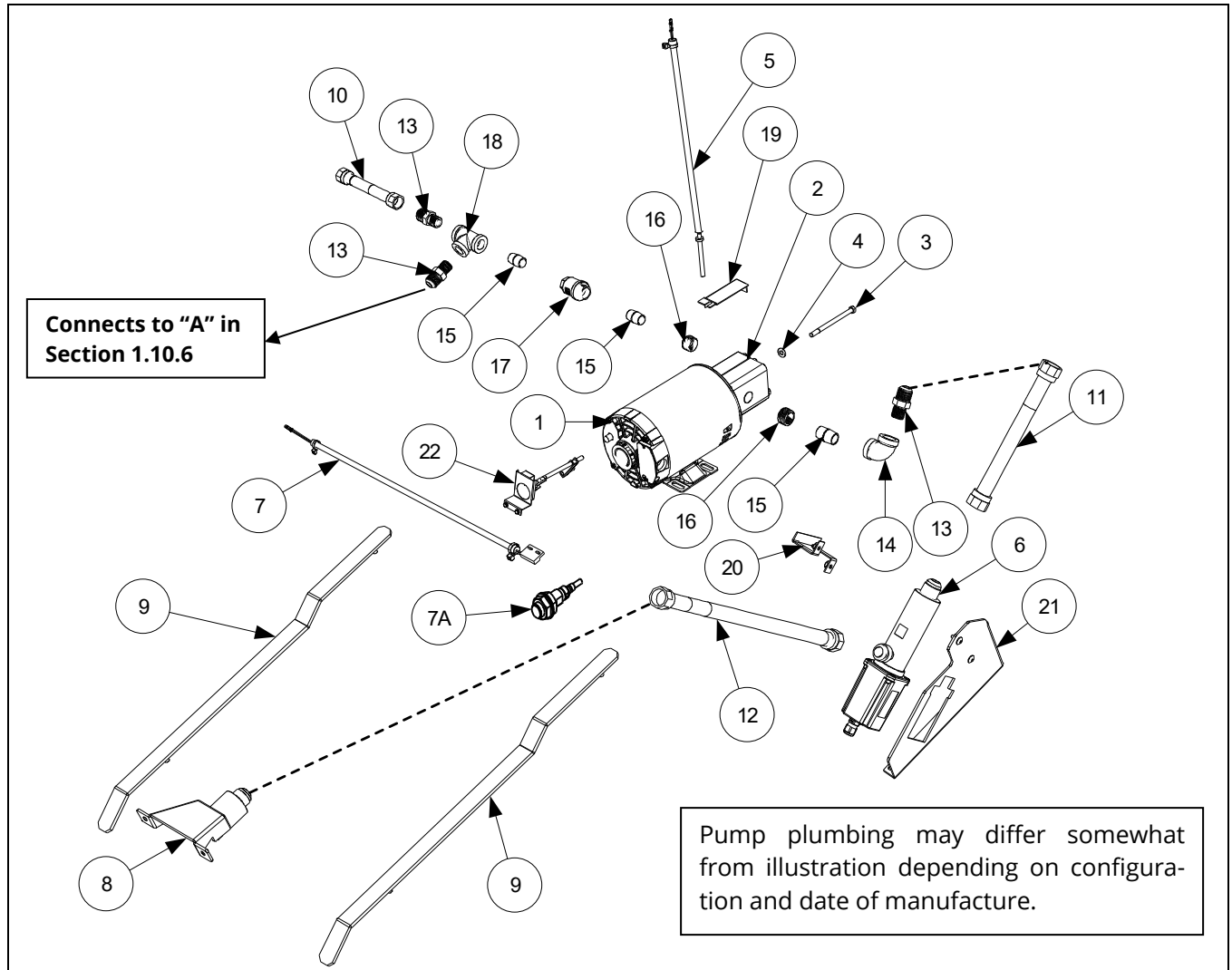

ITEM	PART #	COMPONENT
√ 1		MOTOR AND GASKET KIT
	8261785	100V 50/60 HZ
	8261712	115V 50/60 HZ
	8261756	208V 50/60 HZ
	8261270	220-240V 50/60 HZ
	8261755	250V 50/60 HZ
*	1088658	WIRES, FQG60 PUMP MOTOR POWER
√ 2	8263192	PUMP & GASKET KIT, 8 GPM <b>(INCLUDES 8160093, 8091020 &amp; 8090194)</b>
	8263415	PUMP & GASKET KIT, 8 GPM <b>W/ HEATER HOLE (INCLUDES 8160093, 8091020 &amp; 8090194)</b>
	8160093	GASKET, PUMP/MOTOR
3	8091020	CAP SCREW, 5/16-INCH-18 5.00" NC HEX <b>(CONNECTS PUMP TO MOTOR) (USE 8090194 WASHERS)</b>
4	8090194	WASHERS
*	8071105	HEATER STRIP ASSEMBLY, 100-120V 25W 18"
*	8071098	HEATER STRIP ASSEMBLY, 208-250V 25W 18"
5	1082213	HEATER ASSY, 120V 50W CARTRIDGE <b>(USED IN 8263415 PUMP ABOVE)</b>
6	8263292	SENSOR, FILTERQUICK OQS REPLACEMENT
7	1065876SP	SENSOR ASSY, MAGNETIC POSITION <b>(2FQG60T, 3FQG60T)</b>
7A	130000202	SENSOR, PROXIMITY
8	8239338	BRACKET, FILTER SUCTION <b>(2FQG60T, 3FQG60T)</b>

\* Not illustrated.

√ Recommended parts

### 1.10.3 Filter Pump and Accessories (2FQG60T, 3FQG60T) cont.

ITEM	PART #	COMPONENT
9	8233347	FRAME W/A, SLIDE BASE ( <i>FILTER PAN RAIL</i> ) (2FQG60T, 3FQG60T)
10	8101680	FLEX LINE 5/8" OD X 6.50"
11	8101067	FLEXLINE, 5/8" OD X 8.50"
12	8101369	FLEXLINE, 5/8" OD X 17.50"
13	8101668	ADAPTER, 5/8" TO 1/2" NPT MALE
14	8130062	ELBOW, 1/2" 90° BM
15	8130022	NIPPLE, 1/2 X CLOSE N.P.T. B.M.
16	8130763	BUSHING, 3/4OD X 1/2ID NPT FLUSH
17	8104878	VALVE, INLINE CHECK VALVE 1/2" NPT 1 PSI
18	8130003	TEE, 1/2 X 1/2 X 1/2 BM
19	2207927	BRACKET, FILTER PUMP HEATER MOUNTING
20	2401385	RETAINER, OQS SENSOR FQ
21	2401456	MOUNT, OQS
22	1088713	RESET, FILTER PUMP MOTOR (2FQG60T, 3FQG60T)

\* Not illustrated. ✓ Recommended parts.



### 1.10.5 Plumbing (1FQG60T) - Bulk

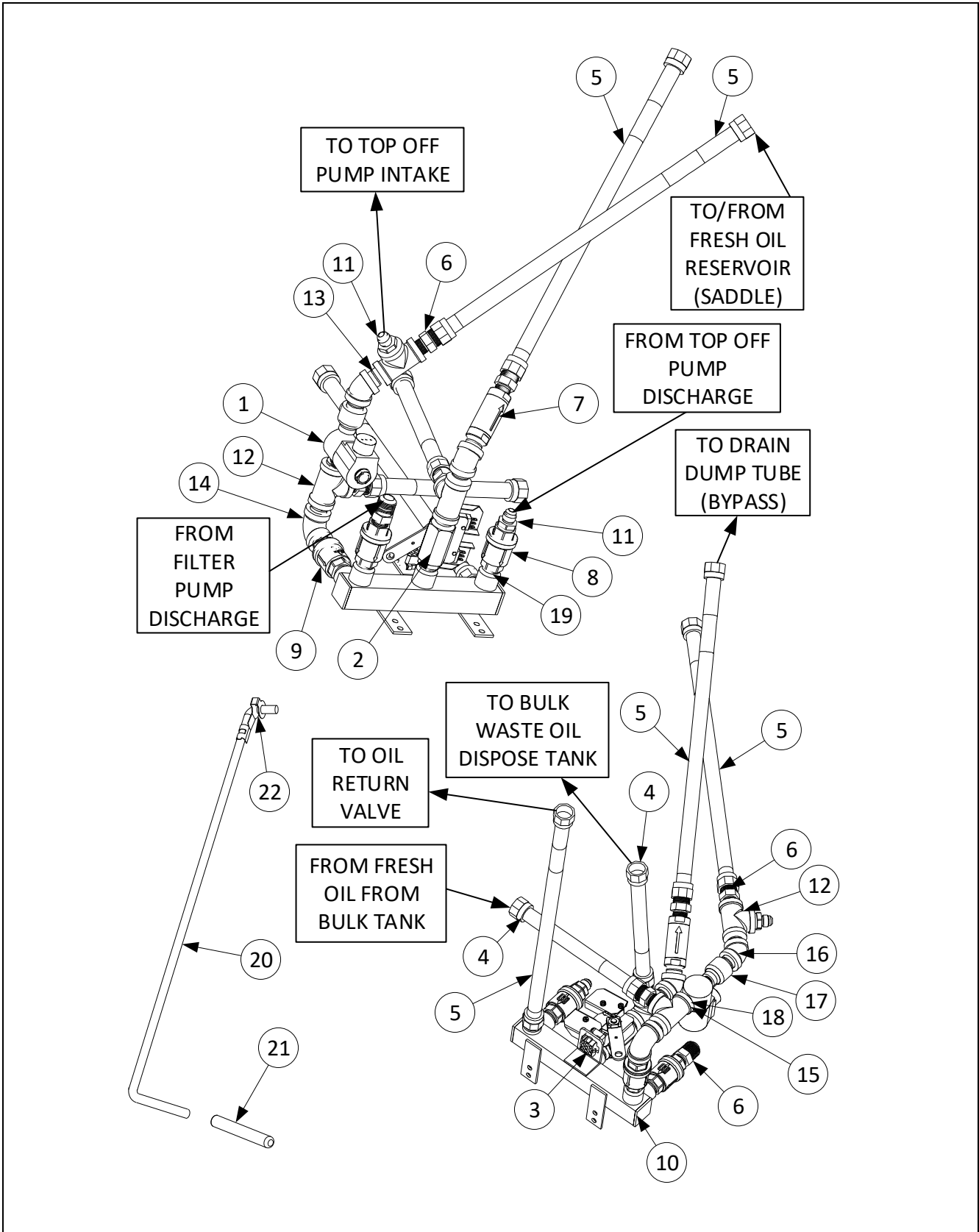

### 1.10.5 Plumbing (1FQG60T) – Bulk cont.

ITEM	PART #	COMPONENT
1	1066830	SOLENOID
2	1080446	VALVE, BULK WASTE ASSEMBLY (SEE SECTION 1.12.1 FOR PARTS)
3	8075789	HARNESS, FILTER QUICK GAS BULK OIL
*	1085398SP	BULK OIL HARNESS PIGTAIL
4	8101067	FLEXLINE, 5/8" OD X 8.50"
5	8101369	FLEXLINE, 5/8" OD X 17.50"
6	8101668	ADAPTOR, MALE 5/8" OD X 1/2"
7	8103531	VALVE, CHECK 1/2" NPT 20PSI
8	8104878	VALVE, INLINE CHECK VALVE 1/2" NPT 1 PSI
9	8104879	VALVE, CHECK 1/2" NPT 4 PSI
10	8104882	MANIFOLD, BULK/RETURN
11	8105019	FITTING, 3/8 FLARE X 1/2 NPT
12	8130003	TEE, 1/2" X 1/2" X 1/2" BM
13	8130022	NIPPLE, 1/2" X CLOSE NPT BM
14	8130062	ELBOW, 1/2" BM 90°
15	8130304	BUSHING, 1/2 X 1/4 BM FLUSH
16	8130345	ELBOW, 1/2" 45° BM
17	8130555	REDUCER, BELL 1/2 TO 1/4 NPT BM
18	8130838	NIPPLE, 1/4" NPT BM CLOSE
19	8130900	NIPPLE, 1/2 X CLOSE NPT S/S
20	2207789	ROD, OIL DISPOSAL BRACKET
21	8160637	CAP, VINYL BLUE
22	8090601	CLIP, CLEVIS LEFT ROD END

### 1.10.6 Plumbing (2FQG60T, 3FQG60T) - Bulk

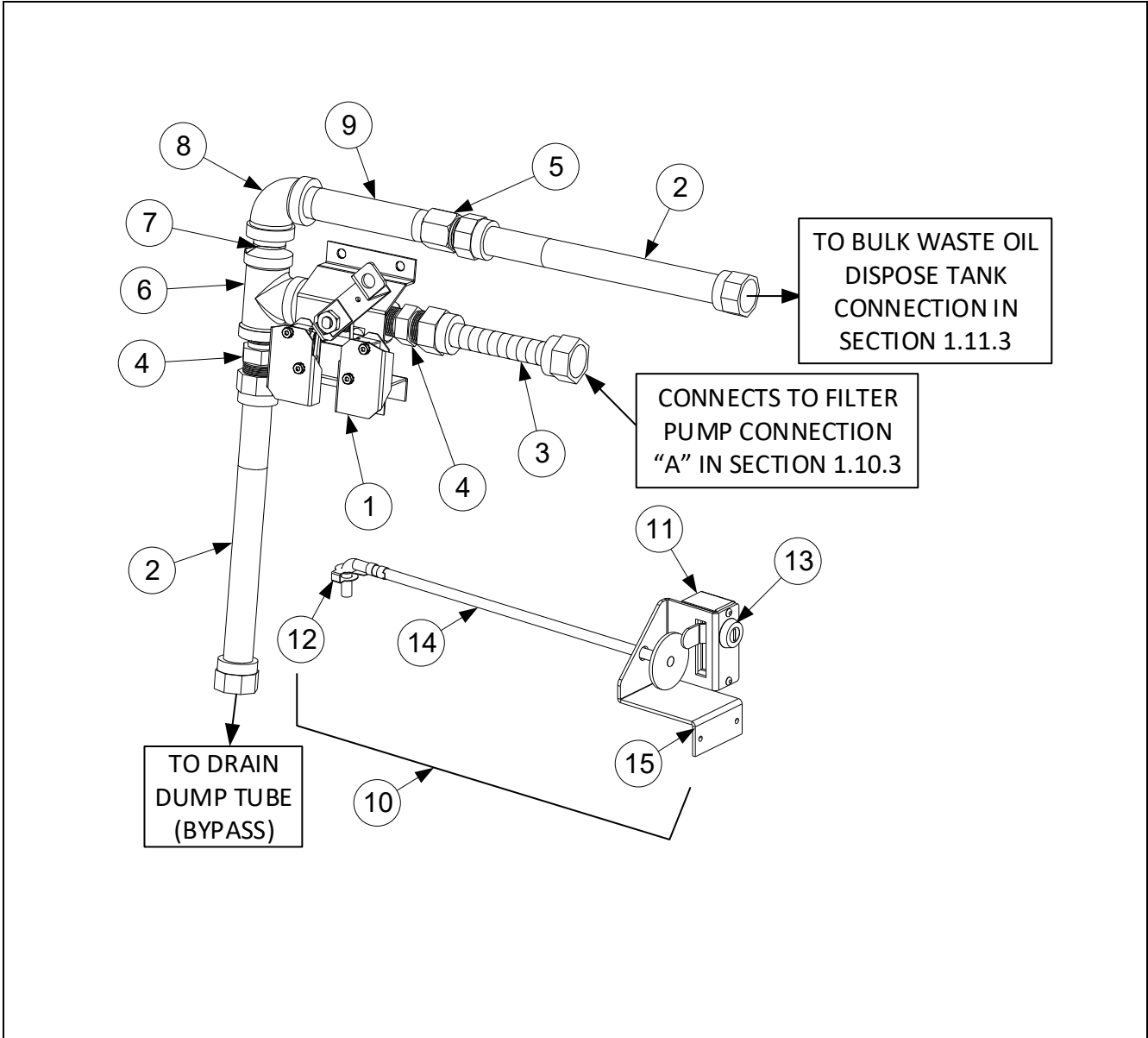

ITEM	PART #	COMPONENT
1	1085923	VALVE, WASTE (SEE SECTION 1.12.1 FOR PARTS)
2	8101067	FLEXLINE, 5/8" OD X 8.50"
3	8101339	FLEXLINE, 5/8" OD X 4.50"
4	8101668	ADAPTOR, MALE 5/8" OD X 1/2"
5	8101669	ADAPTOR, FEMALE 5/8" OD X 1/2"
6	8130003	TEE, 1/2" X 1/2" X 1/2" BM
7	8130022	NIPPLE, 1/2" X CLOSE NPT BM
8	8130062	ELBOW, 1/2" BM 90°
9	8130251	NIPPLE, 1/2" X 4.50-INCHES NPT BM
10	1087486SP	HANDLE BULK DISPOSE
11	2208664	COVER, HANDLE
12	8090601	CLIP, CLEVIS RIGHT ROD END
13	8103587	LOCK, BULK WASTE HANDLE (INCLUDES KEYS)
14	8239336	HANDLE, BULK WASTE PULL
15	2205656	BRACE, BULK HANDLE

## 1.11 ATO (Auto Top-Off) Components

### 1.11.1 Side Saddle Assembly, Top Off Hose and Hose Extension

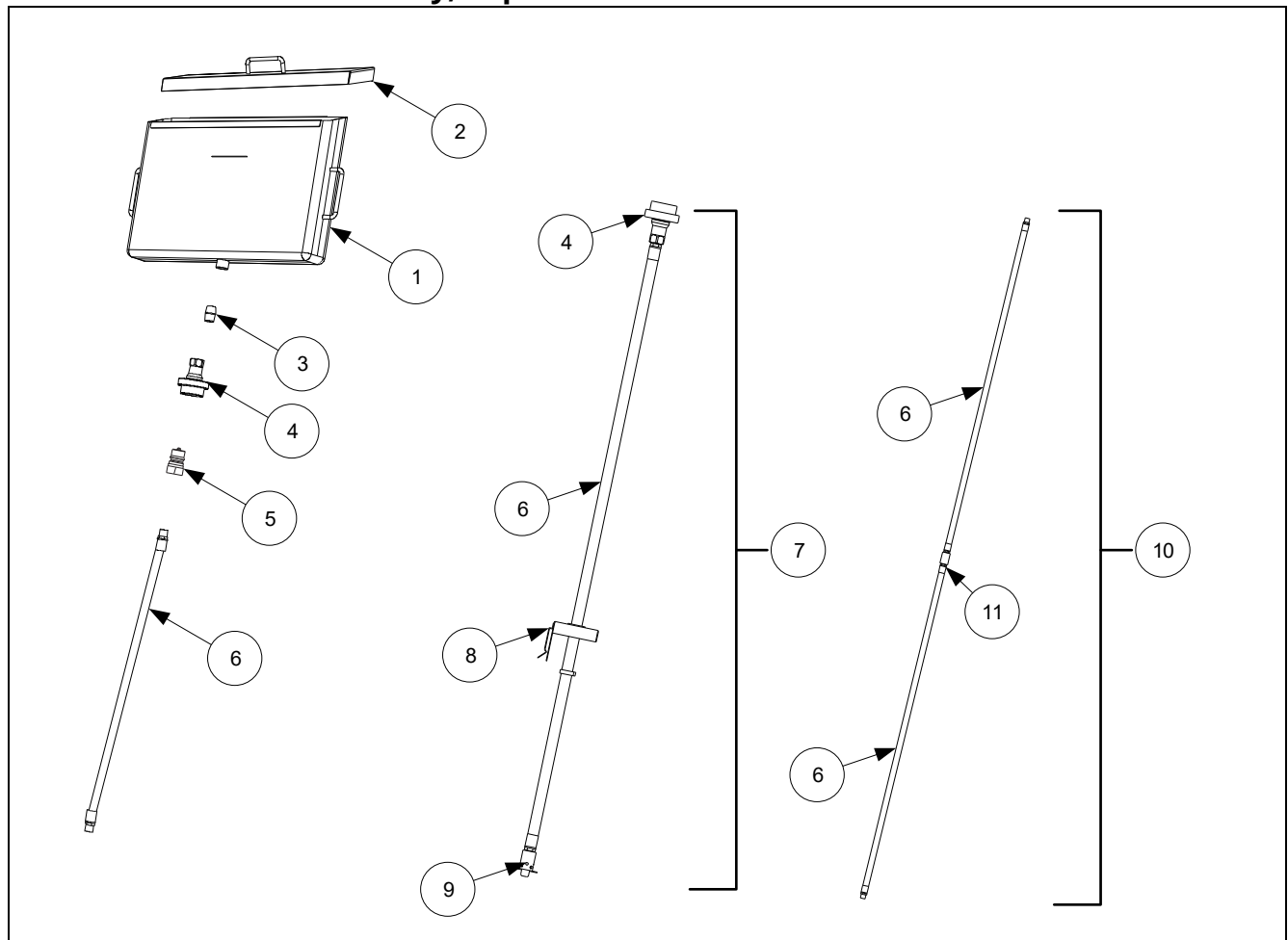

ITEM	PART #	COMPONENT
1	8239596	TANK, OIL SADDLE
2	8239430	LID
3	8130022	NIPPLE, 1/2" X CLOSE N.P.T. B.M.
4	8100490	QUICK DISCONNECT, 1/2" FEMALE
5	8100487	QUICK DISCONNECT, 1/2" MALE
6	8103823	HOSE, JIB/BIB
7	1089083	HOSE ASSY, JIB
8	1082001	CAP ASSY, JIB
9	8237738	TIP ASSY, JIB SUCTION HOSE
10	1088865	HOSE, JIB EXT
11	8130608	COUPLING, 1/2" NPT BM



### 1.11.2 ATO Pump Assembly (1FQG60T)

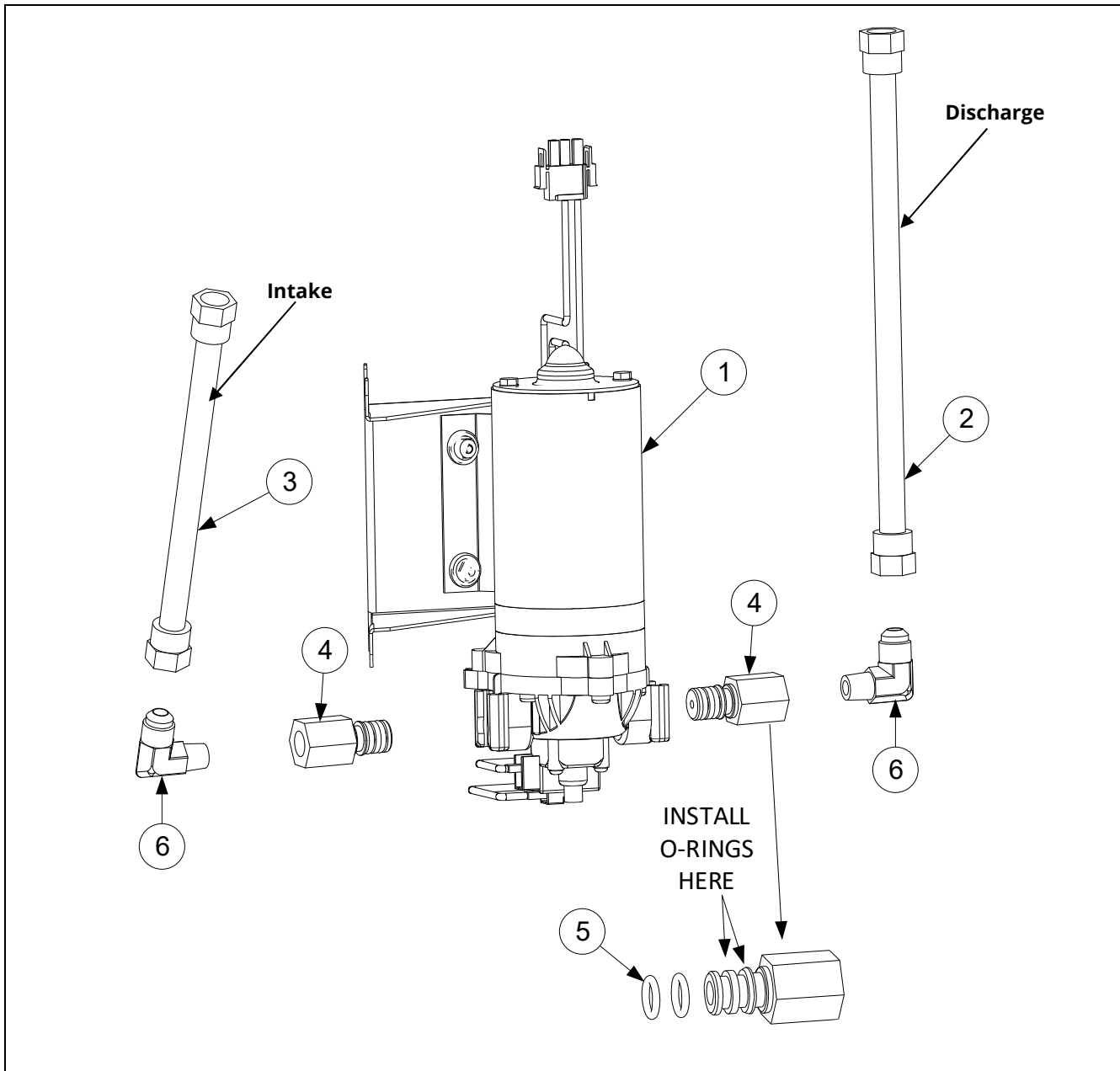

ITEM	PART #	COMPONENT
√ 1	1084372	PUMP, SHURFLO 24VAC (USE 1087890 FOR CE)
2	8103375	FLEXLINE, ½" OD X 17" (DISCHARGE TO BULK PLUMBING MANIFOLD)
3	8104464	FLEXLINE, ½" OD X 10" (INTAKE)
4	1083032	FITTING, SHURFLO PUMP WITH MALE END (INCLUDES O-RINGS)
5	8160782	O-RING, VITON #111
6	8130940	ELBOW, ¼" NPT X ¾" FLARE

√ Recommended parts.

### 1.11.3 ATO Pump Assembly with Bulk (2FQG60T, 3FQG60T)

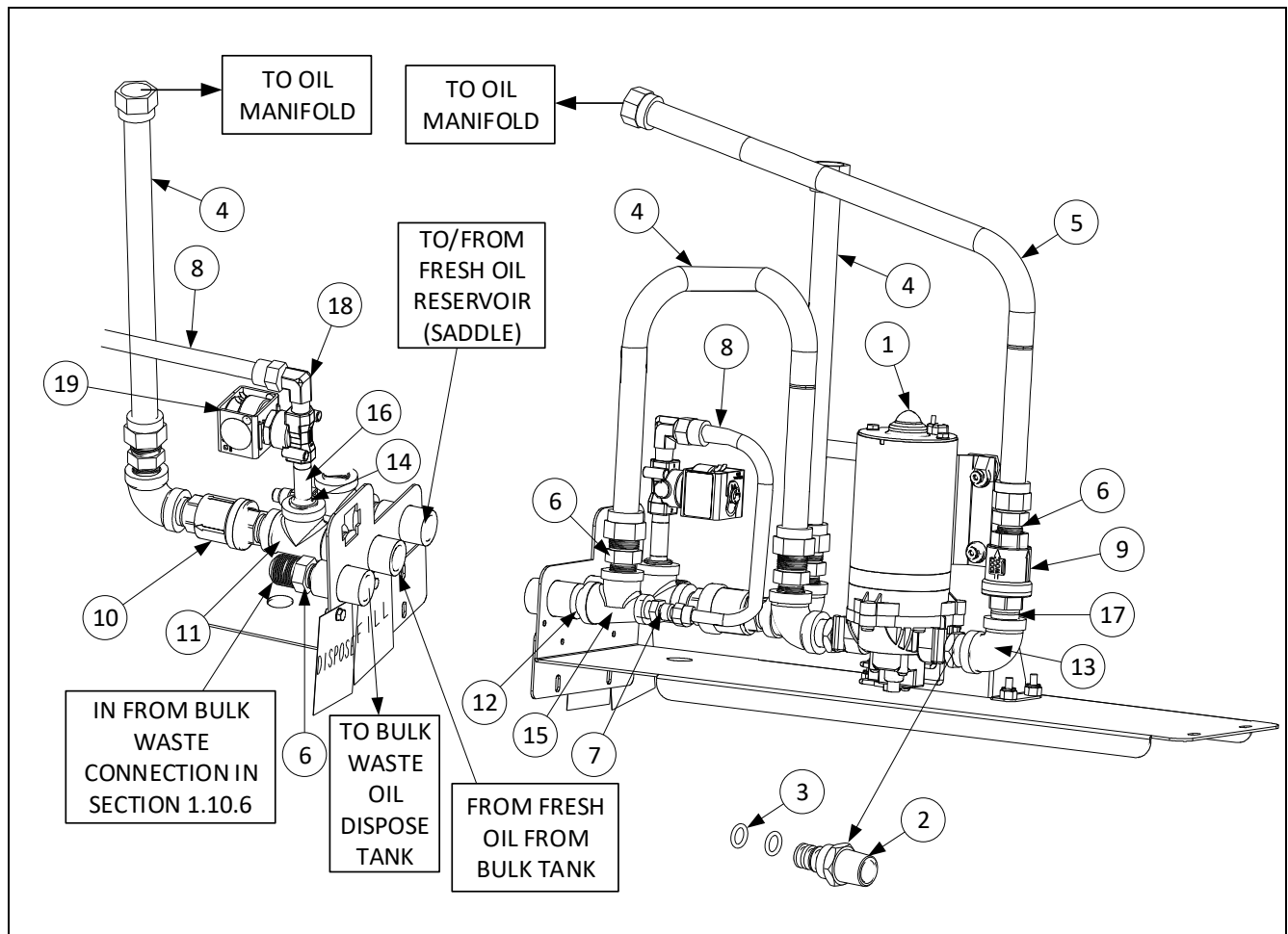

ITEM	PART #	COMPONENT
√ 1	1084372	PUMP, SHURFLO 24VAC (USE 1087890 FOR CE)
2	1082054SP	FITTING, SHURFLO PUMP WITH MALE END (INCLUDES O-RINGS)
3	8160782	O-RING, VITON #111
4	8101055	FLEXLINE, 5/8" OD X 11.50"
5	8101400	FLEXLINE, 5/8" OD X 21.00"
6	8101668	ADAPTOR, MALE 5/8" OD X 1/2"
7	8103270	FITTING, 3/8" FLARE X 1/4" NPT
8	8104464	FLEXLINE, 1/2" OD X 10.00"
9	8104878	VALVE, INLINE CHECK VALVE 1/2" NPT 1PSI
10	8104879	VALVE, CHECK 1/2" NPT 4 PSI
11	8130003	TEE, 1/2" X 1/2" X 1/2" BM
12	8130022	NIPPLE, 1/2" X CLOSE NPT BM
13	8130062	ELBOW, 1/2" 90° BM
14	8130304	BUSHING, 1/2" X 1/4" BM FLUSH
15	8130530	TEE, REDUCING 1/2" X 1/4" X 1/2"
16	8130537	NIPPLE, 1/4" X 2.00" NPT
17	8130900	NIPPLE, 1/2" X CLOSE NPT S/S
18	8130940	ELBOW, 1/4" NPT X 3/8" FLARE
19	1066830	SOLENOID

√ Recommended parts.

## 1.12 Bulk Oil System Components

### 1.12.1 Bulk Oil Dispose Waste Valve

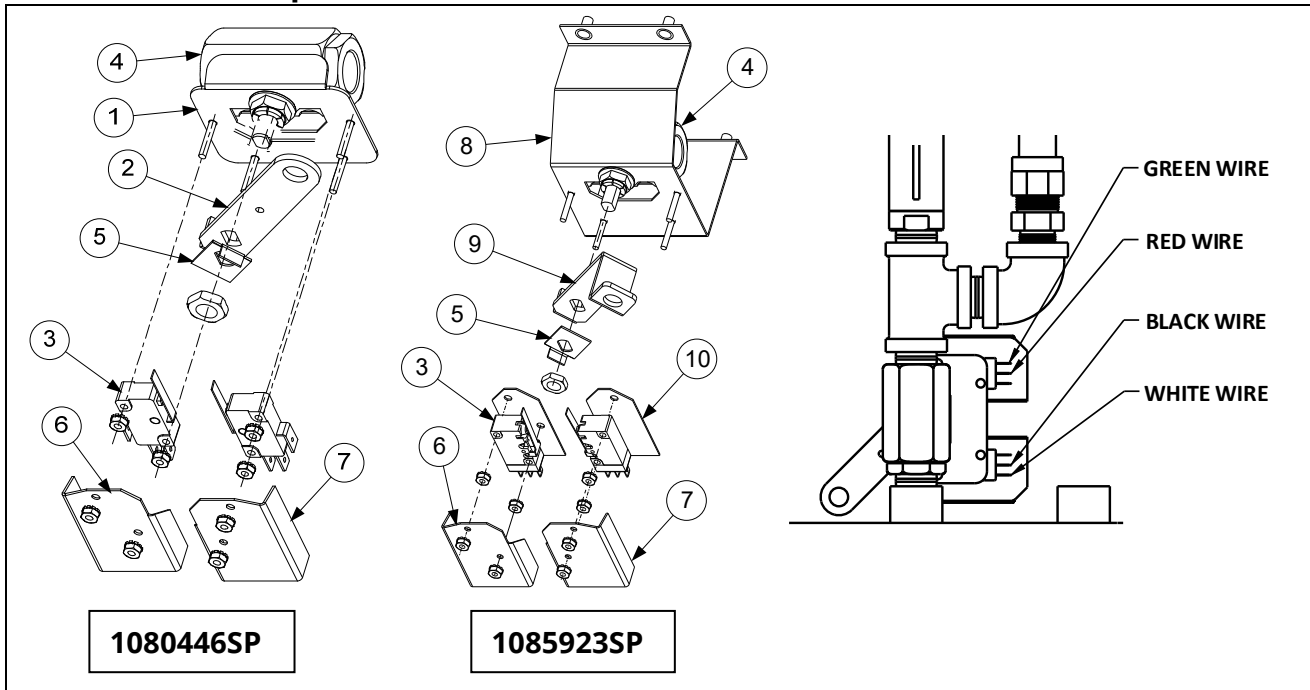

ITEM	PART #	COMPONENT
	1080446SP	VALVE, DISPOSE WASTE
	1085923SP	VALVE, DISPOSE WASTE
1	1080445	BRACKET, RTI WASTE VALVE
2	2205615	HANDLE, RTI WASTE VALVE
3	8074936	MICROSWITCH, GOLD SEALED
4	8100278	VALVE, ½" BALL
5	9002935	RETAINER, NUT RETURN VALVE
6	9012348	COVER, DV SAFETY SWITCH
7	9022348	COVER, DV SAFETY SWITCH
8	1085922	STUD ASSY, WASTE VALVE
9	2205899	HANDLE, GL30 RTI WASTE VALVE
10	8160220	INSULATION, RF SWITCH

### 1.12.2 Bulk Connection - Rear (Prior to 03/2025)

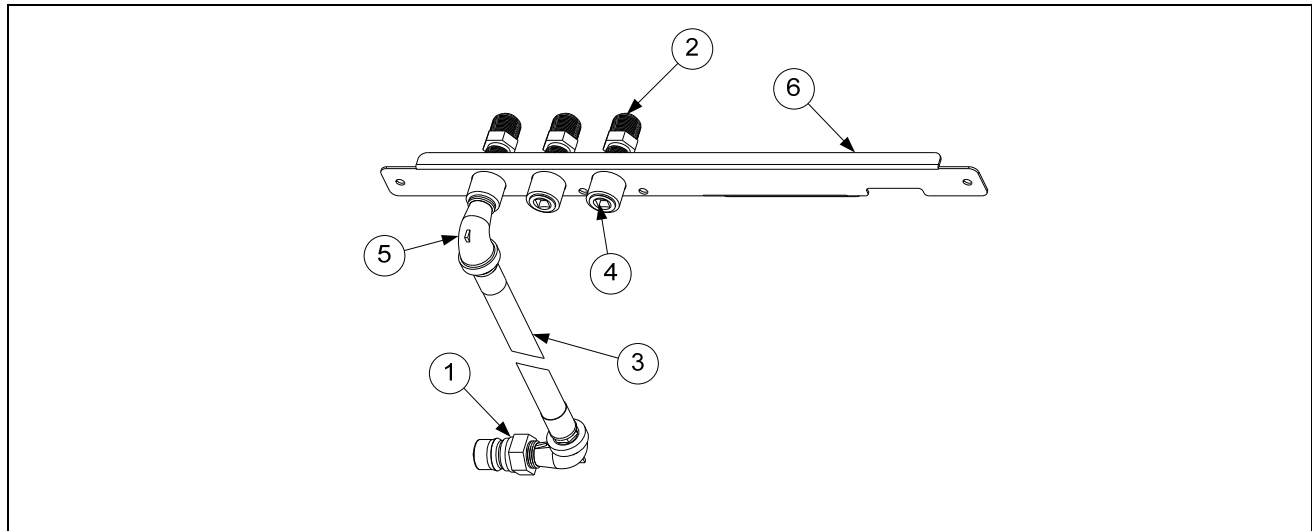

ITEM	PART #	COMPONENT
1	8100487	COUPLING, MALE QUICK DISCONNECT
2	8101668	ADAPTER, 5/8" TO 1/2" NPT MALE
3	8103823	HOSE (CONNECTS TO OIL SADDLE)
4	8130463	PLUG, PIPE 1/2" NPT BM
5	8130616	ELBOW, STREET 1/2" X 1/2" NPT 90°
6	8239204	MOUNT, FQ1814E OIL CONNECTION

### 1.12.2.1 Bulk Connection - Rear (After to 02/2025)

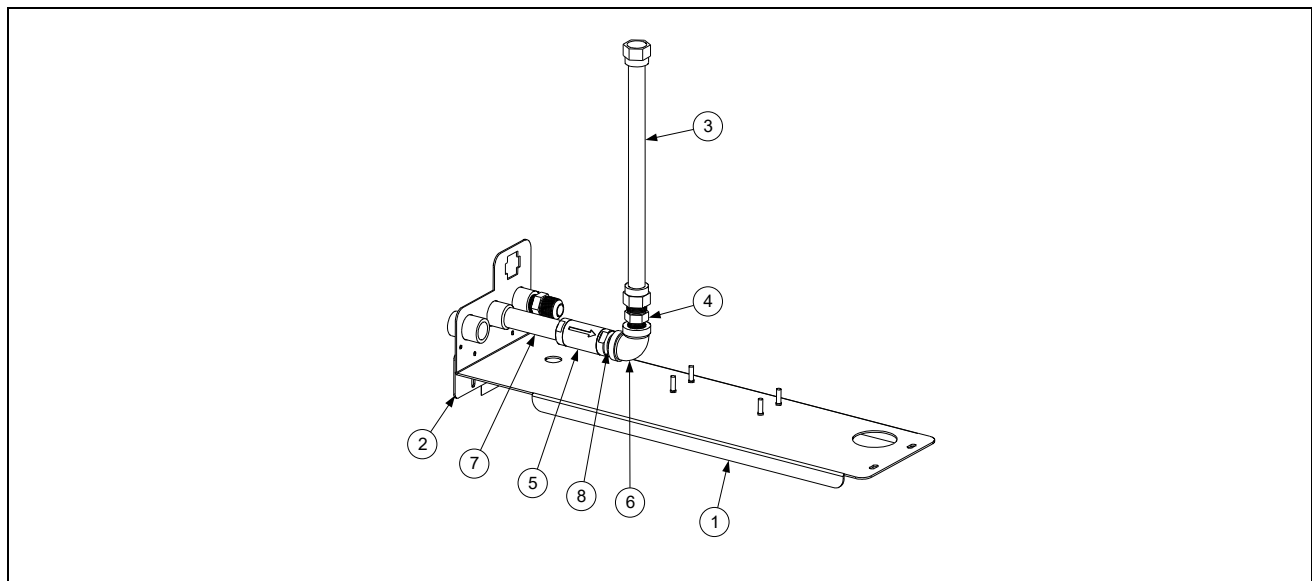

ITEM	PART #	COMPONENT
1	1088637	BASE STUD, FQG60 ATO/BULK PLUMBING
2	2401578	BRACKET, FQG1814G ATO BASE
3	8101055	FLEXLINE, 5/8" O.D. X 1/2"
4	8101668	ADAPTOR, MALE 5/8" O.D. X 1/2"
5	8105101	VALVE, 4-PSI CHECK STRATAFLO
6	8130062	ELBOW, 1/2" BLK 90°
7	8130093	NIPPLE, 1/2 X 4 NPT B.M.
8	8130900	NIPPLE, 1/2 X CLOSE NPT S/S

### 1.12.3 Bulk Connection - Front

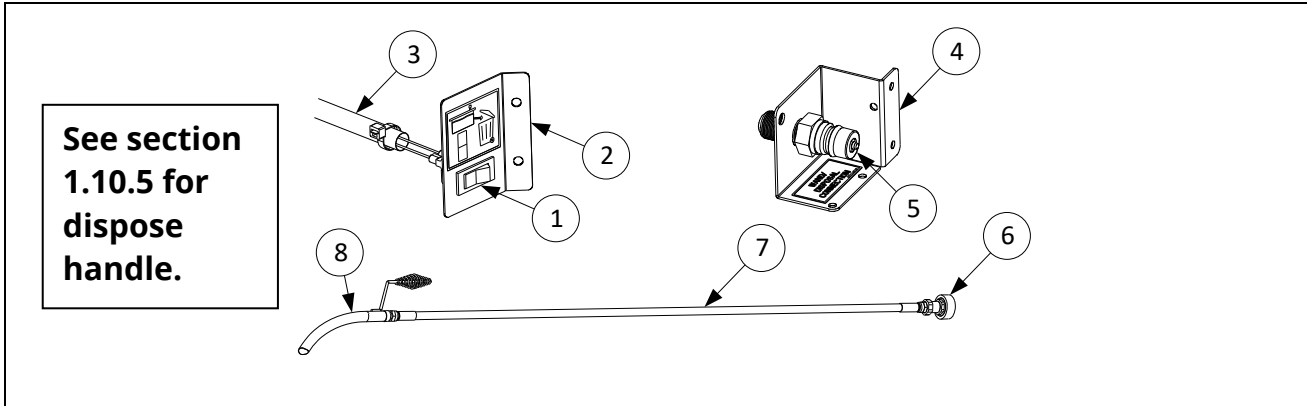

ITEM	PART #	COMPONENT
	1088919	SWITCH, FRONT DISPOSAL
1	8072659	SWITCH, ROCKER
2	2602579	BRACKET, MOMENTARY SWITCH
3	1086024	HARNESS ASSY, FQ GAS FRONT DISPOSAL SWITCH
	1088921	PLUMBING, FRONT DISPOSAL
4	8239615	BRACKET, FRONT OIL DISPOSE
5	8100487	COUPLING, MALE QUICK DISCONNECT
	8068867	WAND ASSEMBLY, OIL DISCARD
6	8100490	QUICK DISCONNECT 1/2" FEMALE
7	8101434	HOSE ASSY, PF STANDARD
8	8100603	WAND

## 1.13 Basket Lift Assembly and Associated Parts

### 1.13.1 Basket Lift Assembly and Associated Parts - June 2012 to June 2013

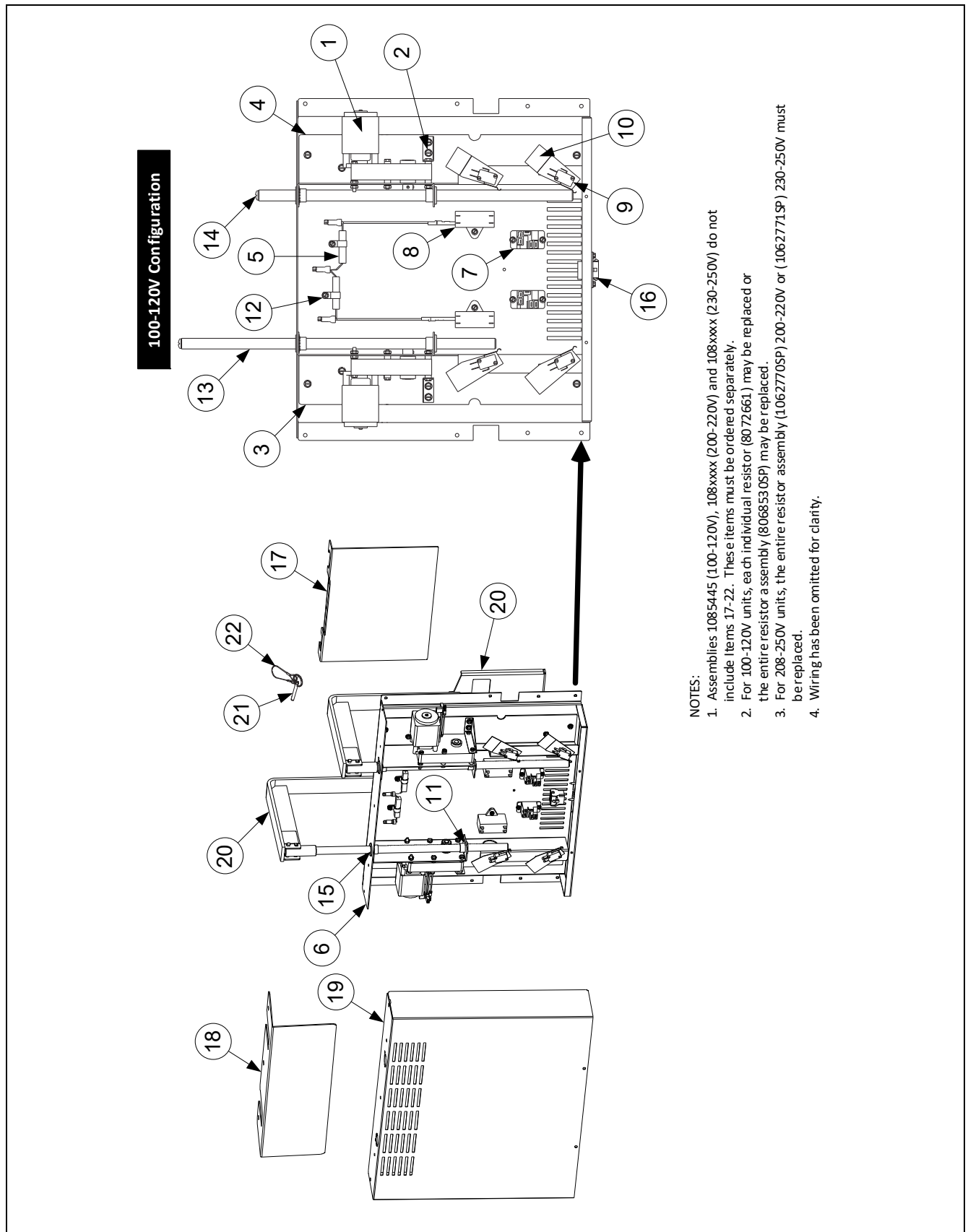

### 1.13.1 Basket Lift Assy and Associated Parts cont. - June 2012 to June 2013

ITEM	PART #	COMPONENT
		<b>BASKET LIFT ASSEMBLIES (SEE NOTE 1 IN ILLUSTRATION)</b>
	1085445SP	BASKET LIFT ASSY, 100-120VAC (ITEMS 1-16) SHOWN <i>Use 8263651 for kit that includes items 1-22.</i>
1	1084181SP	MOTOR ASSY, 100-120VAC MODULAR BASKET LIFT
	1085031SP	MOTOR ASSY, 208-250VAC MODULAR BASKET LIFT
2	2209678	GUSSET, BASKET LIFT MOTOR
3	2219938	CHASSIS, LEFT BASKET LIFT
4	2229938	CHASSIS, RIGHT BASKET LIFT
5		RESISTOR ASSY
	8068530SP	100-120V MODULAR BASKET LIFT (SEE NOTE 2 IN ILLUSTRATION)
	1062770SP	208-220VAC MODULAR BASKET LIFT (SEE NOTE 3 IN ILLUSTRATION)
	1062771SP	230-250VAC MODULAR BASKET LIFT (SEE NOTE 3 IN ILLUSTRATION)
6	8242336	MOUNT WMNT, 1814 MODULAR B/LIFT
*	WIR0166	WIRE ASSY, BASKET LIFT W/ RELAY 200-250VAC
7	8071683	RELAY, 12VDC
8	8072513	CAPACITOR, 12.5 MFD 330VAC
9	8072572	MICROSWITCH
10	8120442	INSULATION, MICROSWITCH
11	8090082	RING, BUSHING RETAINER
12	8090810	CLAMP, NYLON
13	8101012	ROD, MODULAR BASKET LIFT
14	8090129	SCREW, 1/4-20 X 5/8 SLOTTED ROUND HEAD
15	8130035	BUSHING, BRONZE
16	8070159	CONNECTOR, 12-PIN PLUG
*	WIR0166	WIRE ASSY, BASKET LIFT W/ RELAY 200-250VAC
17	2602342	GUIDE, B/L ARM
18	2401715	SHIELD, REAR MODULAR BASKET LIFT COVER
19	2401713	COVER, MODULAR BASKET LIFT
20	8238744	ARM, LEFT MODULAR BASKET LIFT
21	8104852	PIN, 1/4" X 1-5/16" QUICK RELEASE
22	8104854	LANYARD, W/RING

\* Not illustrated.

### 1.13.2 Basket Lift Assembly and Associated Parts - 120V - After June 2013 (Modular)

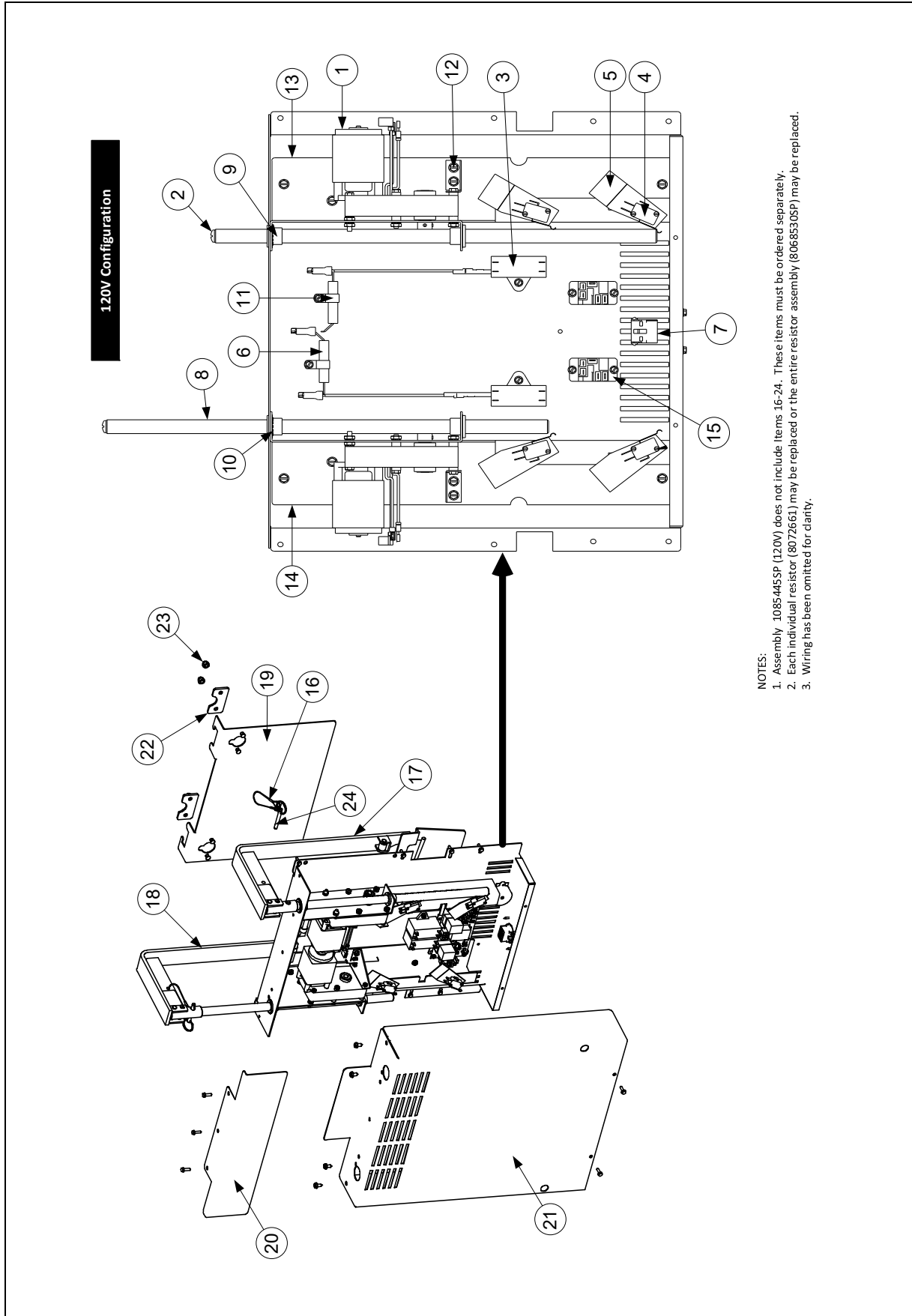



### 1.13.2 Basket Lift Assembly and Associated Parts - 120V - After June 2013 (Modular)

ITEM	PART #	COMPONENT
		<b>Basket Lift Assemblies</b> (see <i>Note 1</i> in illustration)
A	1085445SP	Basket Lift Assy, 120VAC (Items 1-15)
1	1084181SP	Motor Assy, 120VAC Modular Basket Lift
2	8090129	Screw, 1/4-20 X 5/8 Slotted Round Head
3	8072513	Capacitor, Motor Run 12.5 MFD 330VAC
4	8072572	Microswitch
5	8120442	Insulation, Microswitch Box
6	8068530SP	Resistor Assembly (see <i>Note 2</i> in illustration)
7	8070159	Connector, 12 Pin Plug Housing
8	8101012	Rod, Modular BL
9	8130035	Bushing, Bronze
10	8090082	Ring, Bushing Retainer
11	8090810	Clamp, Nylon
12	2209678	Gusset, Reversing Basket Lift Motor
13	2229938	Chassis, D50/FPGL Modular Basket Lift
14	2219938	Chassis, D50/FPGL Modular Basket Lift
15	8071683	Relay, 12VDC
16	8104854	Lanyard, w/Ring
17	8238744	Arm, Left (Illustration May Slightly Differ)
18	8238744	Arm, Right (Illustration May Slightly Differ)
19	2602342	Guide, B/L Arm (Illustration May Slightly Differ)
20	2401715	Shield, Rear Modular B/L Cover
21	2401713	Cover, Modular B/L (Illustration May Slightly Differ)
22	2601474	Cover, Basket Hanger Rivet B/L
23	8090047	Nut, Cap 1/4" -20
24	8104852	Pin, 1/4" X 1-5/16" Quick Release

# 1.14 FilterQuick™ FQG60T Series Wiring

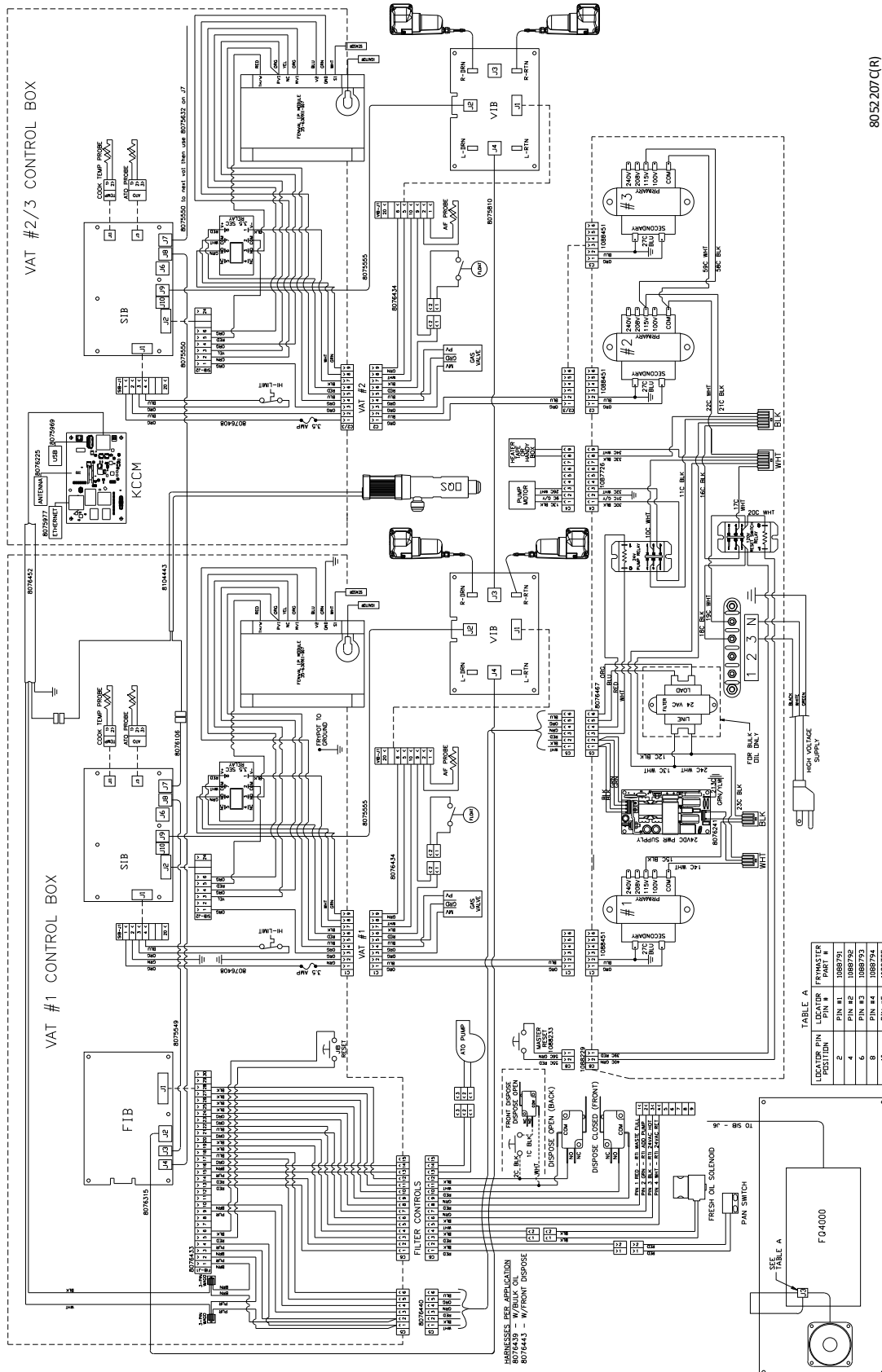

80 52 207 (R)

**THIS PAGE INTENTIONALLY LEFT BLANK**

©2025 Frymaster LLC. except where explicitly stated otherwise. All rights reserved. Continuing product improvement may necessitate change of specifications without notice.

Part Number FRY\_P\_8197918 04/2025

